

FIBERSTRONG® RIM BOARD

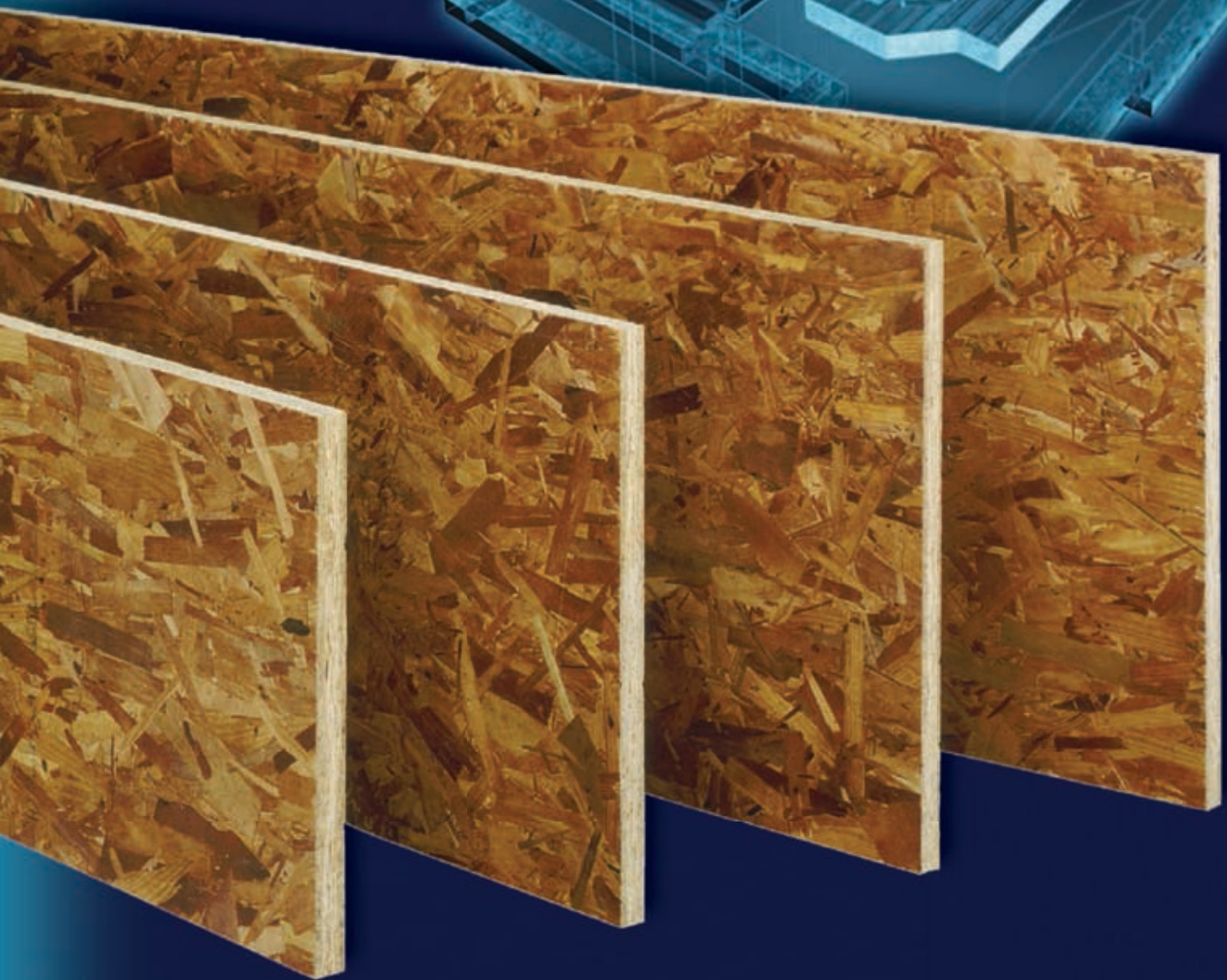

FIBERSTRONG® RIM BOARD

SIZES AND WEIGHTS*

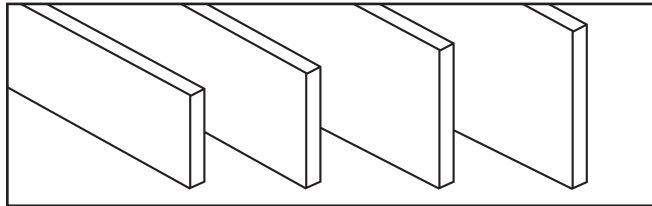

Depth	9 1/2"	11 7/8"	14"	16"
Weight (plf)	3.0	3.7	4.4	5.0
Thickness	1 1/8"			
Length	12'			

*Referenced dimensions are nominal and used for design purposes.

CAPACITIES

Vertical Load:

Rim or starter joist = 4850 plf.

Horizontal load (lateral seismic or wind):

200 plf using a load duration factor of 160%

1/2" lag or through bolt attaching ledger to rim board:

350 lbs. lateral load per bolt

Lateral loads for nails in wide face of rim board:

Design per 2012 NDS using Douglas Fir-Larch values

Meets or exceeds APA Rim Board Plus and ANSI/APA

PRR 410 Grade B2.

CONNECTION REQUIREMENTS

To joist: Face-nail rim board to each joist with two (2) 8d nails, one each into top and bottom flange.

To plate: Toe-nail rim board to wall plate with 8d nails at 6" o.c. or 16d nails at 12" o.c. See note I, page 15 for information regarding fasteners and preservative treated wood.

Subfloor: Attach floor sheathing to rim board per building code or structural panel manufacturer's specifications (closest on-center nail spacing is 6"). For shear transfer (lateral seismic or wind) of up to 200 plf, use 8d at 6" o.c.

To rim: Face-nail rim boards together at corners with three (3) 8d nails.

Ledger: Ledger design and attachment

by others. To attach a ledger use 1/2" through bolts with nuts and washers or 1/2" lag screws (minimum length of 4") with washers (not less than a standard cut washer) under the head and nut meeting ANSI B18.22.1. Maintain 2" edge distances on ledger and rim board. For lag screws, drill 3/16" lead holes in rim board and 1/2" holes in ledger. Caulk holes with high quality caulking immediately before inserting the bolts or lag screws. Caution: The lag screw should be inserted in a lead hole by turning with a wrench, not by driving with a hammer. Over-torquing can significantly reduce the lateral resistance of the lag screw and should therefore be avoided. See note I, page 15 for information regarding fasteners and preservative treated wood.

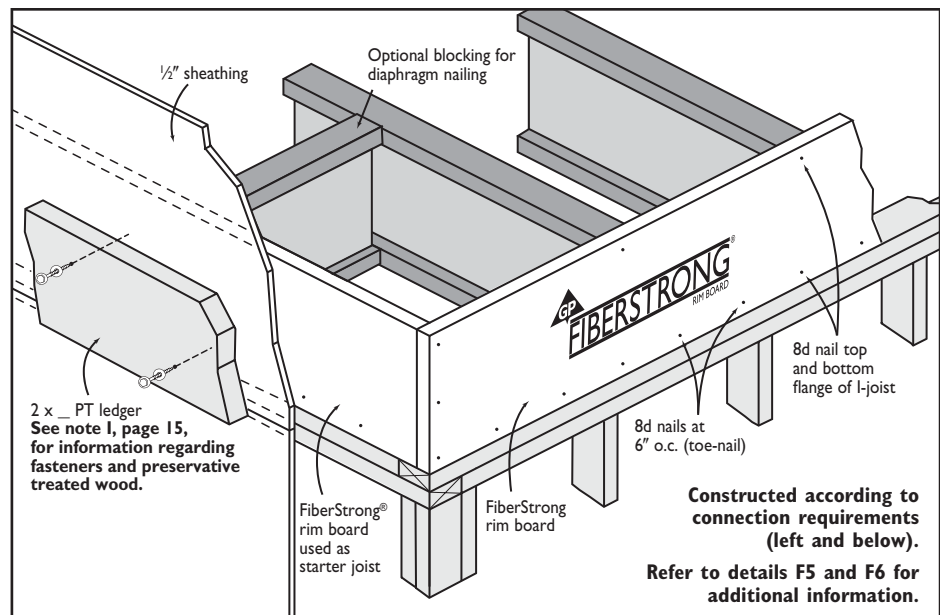

Constructed according to connection requirements (left and below). Refer to details F5 and F6 for additional information.

APPROVED APPLICATIONS

FiberStrong rim board has been tested and approved as a rim board and starter joist by APA-EWS. FiberStrong rim board can also be used as a short span, lightly loaded header (over windows, doors, and vents). The maximum header span is 4 feet. For longer spans, use GP Lam® LVL headers. FiberStrong rim board is not recommended as a structural joist, rafter, or ledger. Instead, consider Wood I Beam™ joists and GP Lam LVL or contact Georgia-Pacific. GP Lam LVL may be substituted for FiberStrong rim board in all rim board and rim joist applications shown in this product guide.

FIBERSTRONG RIM BOARD ALLOWABLE EDGEWISE BENDING DESIGN STRESSES¹

Modulus of Elasticity $E = 0.55 \times 10^6 \text{ psi}^2$

Bending Stress $F_b = 600 \text{ psi}^3$

Horizontal Shear $F_v = 270 \text{ psi}$

Compression Perpendicular to Grain $F_{cL} = 550 \text{ psi}^2$

1. FiberStrong Rim Board is limited to a maximum span of 4 feet. For longer spans use GP Lam headers. Values apply to all depths.
2. All values may be increased for duration of load, except for E and F_{cL} .
3. Allowable bending stress, F_b , has the adjustment for volume effect included in the value.

ENGINEERED FOR PERFORMANCE

WHAT YOU DON'T SEE MATTERS™

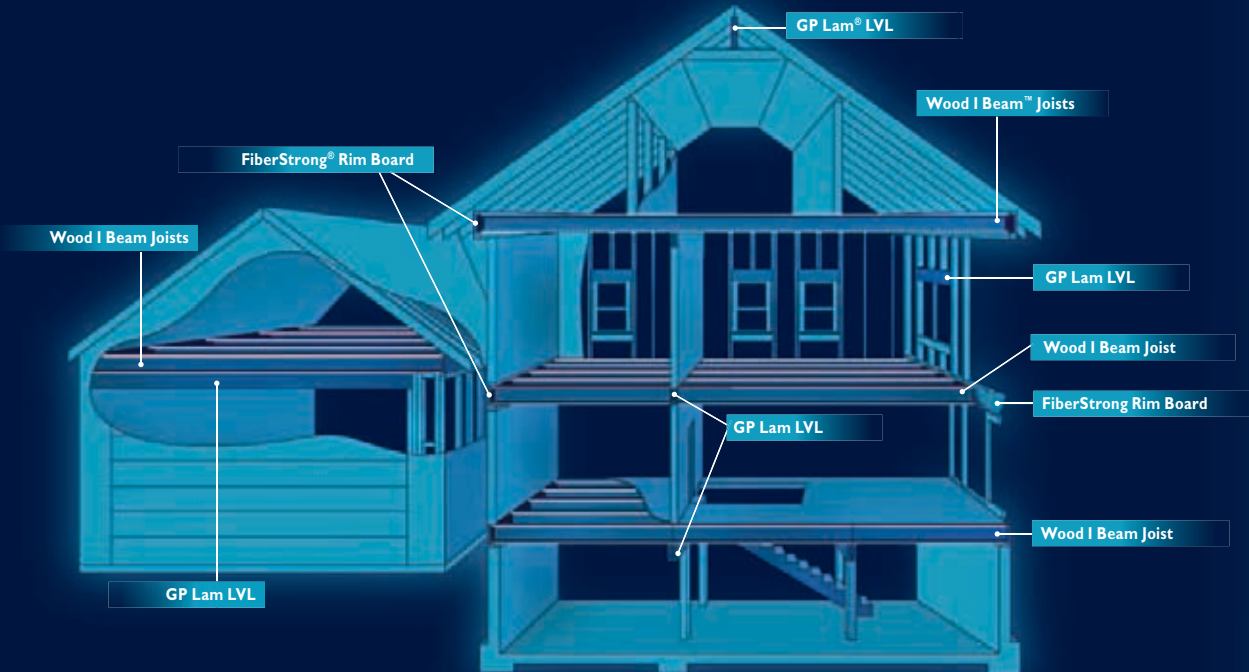

Georgia-Pacific Wood Products LLC
133 Peachtree Street
Atlanta, Georgia 30303
877-437-9759

When it comes to floor joists, rim board, beams and headers, builders and contractors choose Georgia-Pacific engineered lumber for many reasons. Today's residential building trends call for large, open spaces and high ceilings, creating a demand for products that provide higher strength and greater stability over longer spans.

Georgia-Pacific engineered lumber products are covered by a lifetime limited warranty. For complete warranty details, terms and conditions, please visit www.buildgp.com or call 877-437-9759.



This NGBS Green Certified mark is your assurance that a product is Home Innovation NGBS Green Certified for Resource Efficiency and Indoor Environmental Quality. Please visit Homeinnovation.com/Green for more information.



Engineered lumber from Georgia-Pacific is made from wood that is sourced through a system that is third-party certified to the Sustainable Forestry Initiative® (SFI®) procurement standard.

Unless otherwise noted, all trademarks are owned by or licensed to Georgia-Pacific Wood Products LLC. APA Rated and Sturd-I-Floor are registered trademarks of APA-The Engineered Wood Association. TrussLok and FastenMaster are registered trademarks of Olympic Manufacturing Group, Inc. Simpson Strong-Tie is a registered trademark of Simpson Strong-Tie Company, Inc. USP Structural Connectors is a trademark of MiTek USA, Inc. Tough-Glass and Summit are trademarks owned by Atlas Roofing Corp. Monier is a trademark owned by Redland Engineering Limited. Gyp-Crete is a trademark owned by Maxxon Corporation. The Home Innovation NGBS Green Certified logo is a trademark of Home Innovation Research Labs. Sustainable Forestry Initiative and SFI are trademarks of Sustainable Forestry Initiative, Inc. ©2014 Georgia-Pacific Wood Products LLC. All rights reserved. Printed in the U.S.A. 1/14 TM Lit. Item #123040.