

SUBMITTAL: RHG - GALVANIZED STEEL ROOF HATCHES

The Model RHG Series roof hatches provide for normal ladder, step ladder and stair access to roof from interior of the building. Manufactured from galvanized steel with weather-resistant gasketing, these units feature long life, low maintenance and ease of operation. J.L. offers fully welded, mitered corners and box type door design. Units install easily over roof opening and are secured from base flange to roof deck. Designed for one-handed operation.

Certifications: ASTM certified under specifications A792/A792M-06a, A653/A653M-06a, C726-05 and A36/A36M-05. Tested and approved to support a minimum live load of 40 lbs/sq of with a maximum deflection of 1/150th of the span, maximum negative load of 50 lbs/sq ft wind uplift and 110 mph wind load when cover is an open position.

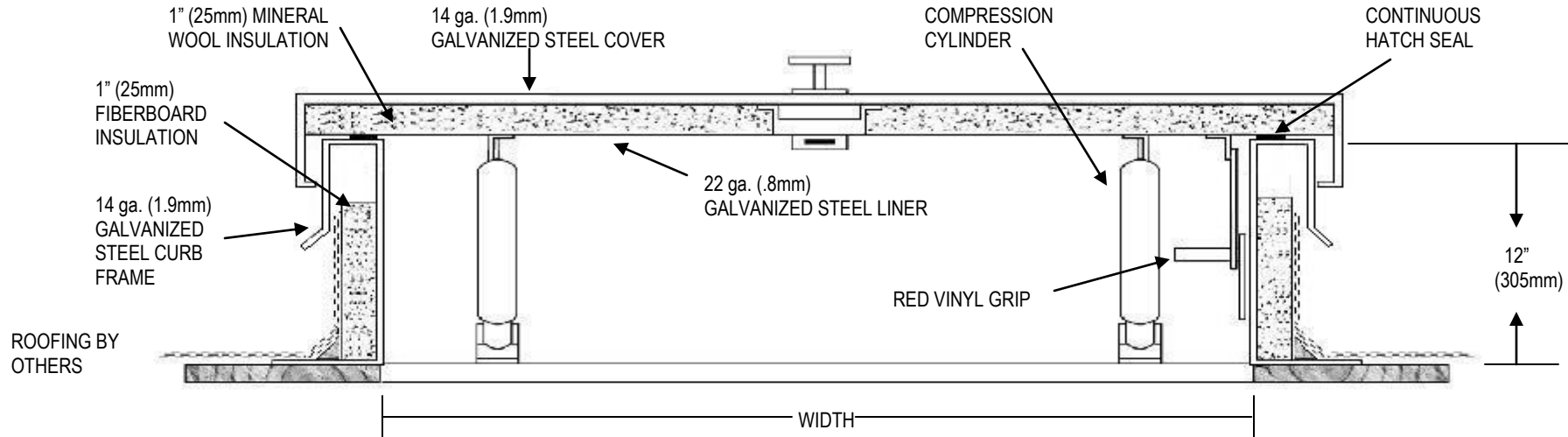

MATERIALS

- Curb:** 14 ga. galvanized steel. 12" high curb with 3-5/8" wide flange including holes for securing to roof deck. (Curb includes integral counter flashing)
- Cover:** 14 ga. galvanized steel., with 22 ga. galvanized steel liner. Hinged on the "width" side.
- Finish:** Grey hammertone powder coat paint on all components that are not zinc-coated.
- Door Seal:** EPDM continuous hatch seal.
- Insulation:** 1" fiberboard insulation surrounding base. 1" mineral wool insulation between exterior door and liner.
- Hardware:** Heavy duty zinc-coated hinge and pin. Fastening hardware is zinc-coated.
- Linkage:** Heavy gauge, automatic hold open arm with red vinyl grip for opening and closing.
- Closure:** Compression operated, shock absorbing cylinder.
- Latch:** Zinc-coated exterior handle and inside locking handle with interior and exterior padlock hasp.

Options at Additional Cost:

- [LP-4, LP-5, LP6](#), Lader Posts (see separate submittals for more information)
- [Saf-T-Hatch Rooftop Safety Railing](#) - (see separate submittal for more information) **Meets OSHA 1910.23.**
- Stainless Steel Hardware:** Hinges, exterior handle, inside locking handle.
- White hammertone finish (WH)** for greater solar heat reflectivity

QTY	MODEL	CURB OPENING		APPROX. SHIPPING WEIGHT
		Width	Length	
	RHG-1	2' 6"	3' 0"	150
	RHG-2	4' 6"	2' 6"	210
	RHG-3	8' 0"	2' 6"	315
	RHG-4	3' 0"	3' 0"	185
	RHG-5	4' 0"	4' 0"	260
Other Sizes Available—Contact Customer Service				



RHG with Optional Saf-T-Hatch Railing

Double Wall RHG—See separate submittal

 ACTIVAR INC. <small>www.activarcpg.com</small> Construction Products Group	Distributor:	Quantity:
	Contractor:	Approved By:
	Model #:	Architect:
	Project:	Date:

HEADQUARTERS & JL INDUSTRIES: 4450 WEST 78TH ST CIRCLE, BLOOMINGTON, MN 55435-5416 PH: 800-554-6077 FAX: 952-835-2218 EMAIL: SALES@JLINDUSTRIES.COM WWW.ACTIVARCPG.COM
 ACPG SOUTHEAST (THOMAS ENTERPRISES): FT MYERS, FL ACPG WEST COAST (SAMSON): COMMERCE, CA WAREHOUSES: DALLAS TX, LANCASTER PA, ATLANTA GA, CHICAGO, IL, SEATTLE WA 5/7/13