

ICC Evaluation Service, Inc.
www.icc-es.org

Business/Regional Office ■ 5360 Workman Mill Road, Whittier, California 90601 ■ (562) 699-0543
Regional Office ■ 900 Montclair Road, Suite A, Birmingham, Alabama 35213 ■ (205) 599-9800
Regional Office ■ 4051 West Flossmoor Road, Country Club Hills, Illinois 60478 ■ (708) 799-2305

DIVISION: 09—FINISHES

Section: 09260—Gypsum Board Assemblies

REPORT HOLDER:

GYPSUM ASSOCIATION
810 FIRST STREET, N.E., SUITE 510
WASHINGTON, DC 20002
www.gypsum.org

EVALUATION SUBJECT:**GYPSUM BOARD INTERIOR AND EXTERIOR APPLICATIONS****1.0 EVALUATION SCOPE****Compliance with the following codes:**

- 2003 *International Building Code*® (IBC)
- 2003 *International Residential Code*® (IRC)
- 1997 *Uniform Building Code*™ (UBC)

Properties evaluated:

- Interior finish classification
- Fire-resistance rating
- Thermal barrier
- Exterior finish

2.0 USES

The gypsum products described in this evaluation report are recognized for specific interior and exterior applications.

3.0 DESCRIPTION**3.1 Water-resistant Gypsum Backing Board:**

The backing board shall conform to ASTM C 630 or ASTM C 1396.

3.2 Gypsum Wallboard:

The wallboard shall conform to ASTM C 36 or ASTM C 1396.

3.3 Exterior Soffit Board:

The soffit board shall conform to ASTM C 931 or ASTM C 1396.

3.4 Sheathing Board:

The sheathing board shall conform to ASTM C 79 or ASTM C 1396.

4.0 INSTALLATION

Gypsum board interior and exterior applications as described below are in compliance with this report.

4.1 Fire-resistance-rated Assemblies:

When gypsum board is used in fire-resistance-rated floor/ceiling, roof/ceiling, or wall assemblies, the board thickness, type of gypsum board, and the construction of the assembly shall comply with Chapter 7 of the IBC or the UBC; Section R317 of the IRC; the 17th edition of the *Gypsum Association Fire Resistance Design Manual*; or current ICC-ES evaluation reports.

4.2 Walls and Ceilings in Shower and Bath Areas:

4.2.1 Attachment: Full-size sheets of minimum 1/2-inch-thick (12.7 mm), water-resistant gypsum backing board shall be applied with the long dimension perpendicular to supports and attached with nails, or drywall screws complying with ASTM C 1002, spaced not more than 8 inches (203 mm) on center, except that where ceramic tile is more than 3/8 inch (9.5 mm) thick, the nails or drywall screws shall be spaced a maximum of 4 inches (102 mm) on center.

Gypsum board shall not be used in areas subject to continuous high humidity, such as saunas, steam rooms, gang shower rooms or indoor pools.

Fire-resistance-rated construction requires Type X, water-resistant gypsum backing board, with the board thickness and method of attachment as prescribed by the applicable code or by a current ICC-ES evaluation report.

For fire-resistance- or sound-transmission-rated construction, the gypsum board shall extend from floor to ceiling. All layers of gypsum board shall be water-resistant gypsum backing board installed without adhesive.

4.2.2 Framing: The maximum spacing of wood or steel studs 2 1/2 inches (64 mm) deep or less is 16 inches (406 mm) on center. Studs 3 1/2 inches (89 mm) deep, or more, are permitted to be spaced a maximum of 24 inches (610 mm) on center, provided there is blocking or backing 1 inch (25.4 mm) above the top of the tub or receptor and at all gypsum board horizontal joints in the area that receives tile. Approved blocking, headers or framing shall support the tub, plumbing fixtures, soap dishes, grab bars, towel racks, and similar items. Approved framing shall reinforce interior angles to provide rigid corners.

4.2.3 Vapor Retarders: The water-resistant gypsum backing board, which is the base layer for tile or wall panels in tub and shower enclosures, shall not be foil-backed. A vapor retarder shall not be installed behind the gypsum backing board located on exterior walls of shower and bath areas.

4.2.4 Building Paper: Building paper required in Section 2306.13 of the UBC may be omitted; however, when used, it shall not be a vapor-retarder type.

4.2.5 Receptors: The position of the projecting lips of the tub or shower receptor or pan, with respect to the studs, shall

be flush with the outside face of the water-resistant gypsum backing board. See Figure 1 of this report for details. Shower pans, receptors, or tubs shall be installed before installation of the gypsum board. Minimum clearance is $\frac{1}{4}$ inch (6.4 mm) between the paper bound edge of the water-resistant gypsum backing board and the tub or shower receptor or pan.

4.2.6 Joint Treatment: Gypsum board joints, including those at all angle intersections, which are under areas to receive tile or wall panels, shall be treated with joint compound and tape, but shall not be finish-coated. All cut edges and openings around pipes and fixtures shall be treated with an approved, water-resistant, flexible compound or caulk. Areas to be tiled that are covered with a joint compound shall be skim-coated with bedding adhesive. The bedding adhesive for ceramic tile shall conform to ANSI A136.1 for Organic Adhesives for Installation of Ceramic Tile, Type I.

4.2.7 Ceiling Application: Water-resistant gypsum backing board is permitted to be used on ceilings of bath and shower areas under the following conditions:

1. For IBC or IRC compliance: The maximum spacing of ceiling framing shall be 12 inches (305 mm) on center for $\frac{1}{2}$ -inch-thick (12.7 mm), water-resistant gypsum backing board, and a maximum of 16 inches (406 mm) on center for $\frac{5}{8}$ -inch-thick (15.9 mm), water-resistant gypsum backing board.
2. For UBC compliance: The maximum spacing of ceiling framing shall be 12 inches (305 mm) on center for any thickness of water-resistant gypsum backing board, provided the installation complies with UBC Section 2512.

4.3 Exterior Ceiling Surfaces:

4.3.1 Location: Exterior gypsum soffit board may be used as a ceiling finish at exterior locations such as carports, open porches, walkways, soffits and similar installations that are horizontal or inclined downward away from the building. Gypsum wallboard is permitted for use as a ceiling finish at exterior horizontal applications not exposed to the weather as defined by Section 2502 of the IBC, Section R702.3.5 of the IRC and Section 224 of the UBC.

4.3.2 Framing: Maximum spacing of framing members shall be 16 inches (406 mm) on center when supporting $\frac{1}{2}$ -inch-thick (12.7 mm) board, and shall be 24 inches (610 mm) on center when supporting $\frac{5}{8}$ -inch-thick (15.9 mm) board. Gypsum board applications perpendicular to framing members shall comply with ASTM C 840 (IBC), Table R702.3.5 of the IRC, or Table 25-G of the UBC.

4.3.3 Joints: In ceiling areas having long runs, the maximum spacing of expansion joints shall be 30 feet (9.144 m). A $\frac{1}{4}$ -inch (6.4 mm) clearance joint is required between gypsum board and adjacent walls, fascia, beams or columns. Fascia boards shall extend downward past the ceiling board surface a minimum of $\frac{1}{4}$ inch (6.4 mm). Exterior gypsum soffit board or gypsum wallboard joints and fastener heads shall be provided with joint treatment. An alternate joint treatment is batten strips.

4.3.4 Surface Treatment: The exterior gypsum soffit board exposed to weather and the gypsum wallboard not exposed to weather shall have one of the following surface treatments applied at the jobsite:

1. One coat of latex exterior paint applied over an oil-base primer.
2. Two coats of a spirit-thinned oil or alkyd base exterior paint.

4.4 Exterior Wall Applications:

4.4.1 For IBC Compliance: Since the IBC does not classify water-resistant-core gypsum sheathing as a water-repellent panel, exterior walls sheathed with water-resistant-core gypsum sheathing shall be protected with a water-resistive barrier complying with Section 1404.2 of the IBC.

4.4.2 For IRC Compliance: A weather-resistant sheathing paper shall be installed over the water-resistant-core gypsum sheathing as required by Section R703.2 and Table R703.4 of the IRC. The sheathing paper may be omitted where approved siding is installed over the sheathing or where excepted by the IRC.

4.4.3 For UBC compliance: Since water-resistant-core gypsum sheathing is considered a water-repellent panel in accordance with Case 4 of Section 1402.1 of the UBC, the weather-resistive barrier required by UBC Section 1402.1 may be omitted where approved siding is applied over the sheathing. When portland cement plaster conforming to Chapter 25 of the UBC is the exterior wall covering, paper-backed lath, installed in accordance with Chapter 25 of the UBC, shall be applied over the water-repellent gypsum sheathing. Portland cement plaster requires weep screeds in accordance with UBC Chapter 25.

4.5 Roof Assembly Application:

4.5.1 For IBC or IRC compliance: When wood shake or wood shingle roof construction is in accordance with the IBC or IRC, the gypsum board shall be covered with an approved underlayment in accordance with IBC Sections 1507.8.3 and 1507.9.3; and IRC Sections R905.7.3 and R905.8.3.

4.5.2 For UBC compliance: When construction is in accordance with the UBC, gypsum board products specified in this section are permitted to be used as underlayment for wood shake or shingle roofing. The $\frac{5}{8}$ -inch-thick (15.9 mm), Type X, water-resistant gypsum backing board or water-repellent gypsum backing board or sheathing shall be placed under minimum $\frac{15}{32}$ -inch-thick (11.9 mm) wood structural panels or 1-inch-thick (25 mm) spaced sheathing. Except for filler strips, board width shall be 48 inches (1210 mm). Application of the wood structural panel shall comply with Sections 2315.3.1 and 2312.2 of the UBC, provided the nail size is increased to achieve minimum embedment lengths. The deck, whether solid or spaced boards, shall be overlaid with a layer of approved nonbituminous saturated felt lapped 2 inches (51 mm) on horizontal and vertical joints. Wood shake and shingle grading and application shall comply with Chapter 15 of the UBC.

4.6 Thermal Barrier:

Regular gypsum board, a minimum of $\frac{1}{2}$ inch (12.7 mm) thick, is permitted to be used as a thermal barrier in accordance with Section 2602.4 of the UBC; or Sections 2603.4 or 2603.5.2 of the IBC; or Section R314.1.2 of the IRC. The gypsum board shall be attached in such a manner that it will remain in place for 15 minutes of fire exposure. For walls constructed of wood framing, attachment of the gypsum board in accordance with with Table 25-G of the UBC, or ASTM C 840 (IBC), or IRC Section R702.3.5, is permitted. For other construction, attachment of the gypsum wallboard shall comply with a specific ICC-ES evaluation report, or the method of attachment shall be qualified by testing in accordance with UBC Standard 26-3 (UBC); or FM 4880, UL 1040, NFPA 286 or UL 1715 (IBC and IRC).

4.7 Ceiling Diaphragms:

In jurisdictions enforcing the IBC, ceiling diaphragm construction shall be in accordance with IBC Section 2508.5

In jurisdictions enforcing the UBC, the following construction is applicable: Allowable shear values for gypsum board

ceiling diaphragms that resist wind or earthquake forces are set forth in Table 1 of this report. The ceiling diaphragm is not permitted to laterally support masonry or concrete walls or permanent lateral loads. Framing members shall be minimum nominal 2-by-6-inch (50 by 152 mm). Values are not cumulative with other horizontal diaphragms. Perimeter nominal 2-by-6 or 2-by-8 (50 by 152 mm or 50 by 203 mm) blocking shall be installed flat over the top plate, providing a minimum 2-inch-wide (51 mm) nailing surface for the gypsum board. Nail edge and end distances are a minimum of $\frac{3}{8}$ inch (9.5 mm). The diaphragm height-to-length ratio is a maximum of 2:1, spanning between shear-resisting elements. Rotation or cantilevered conditions are not permitted. Continuous gypsum board end joints parallel to framing members are not permitted.

4.8 Shear Walls:

Table 2 of this report shows maximum allowable shear values for gypsum board shearwalls. Gypsum board is applied either horizontally or vertically on nominal 2-by-4 (50 by 102 mm) wood studs. Additionally, Table 22-VIII-B of the UBC or Section 2505 of the IBC is applicable.

5.0 CONDITIONS OF USE

Gypsum Board Interior and Exterior Applications described in this report comply with those codes specifically listed in Section 1.0 of this report, subject to the following conditions:

- 5.1 Installation complies with this report, the Gypsum Association published installation instructions and the applicable code.
- 5.2 Calculations and details shall be submitted to the code official for approval of structural-use applications.
- 5.3 Documentation shall be submitted to the code official verifying that the gypsum board products to be installed comply with the applicable standard noted in Section 3.0 of this report.
- 5.4 The evaluation of GA File Nos. FC 4340 and FC 4370 is outside the scope of this evaluation report.

6.0 EVIDENCE SUBMITTED

- 6.1 Reports of physical and racking shear wall testing.
- 6.2 Reports of fire-resistance testing in accordance with ASTM E119 for 34 generic assemblies added to the 17th edition of the *Gypsum Association Fire Resistance Design Manual*.

7.0 IDENTIFICATION

The gypsum board shall be identified by the manufacturer's name, the product name and the ASTM specification number. Gypsum board products that have been evaluated by ICC-ES for compliance with the standards in Section 3.0 shall also be identified by the ICC-ES report number associated with the product.

TABLE 1—ALLOWABLE SHEAR FOR GYPSUM BOARD APPLIED TO CEILING FRAMING IN HORIZONTAL DIAPHRAGMS¹ (lb/ft)

BOARD THICKNESS (in.)	NAIL TYPE ²	FRAME SPACING (in.) ³	
		16 o.c.	24 o.c.
$\frac{1}{2}$	5d cooler	90	70

For SI: 1 inch = 25.4 mm, 1 plf = 14.6 N/m.

¹The values are not cumulative with other horizontal diaphragm values. Values shall be reduced by 50 percent in UBC Seismic Zones 3 and 4.

²Nail spacing is 7 inches on center at all supports.

³Solid blocking is required at all gypsum board joints.

TABLE 2—ALLOWABLE SHEAR FOR WIND OR SEISMIC FORCES IN POUNDS PER FOOT FOR VERTICAL DIAPHRAGMS OF GYPSUM BOARD WOOD-FRAMED WALLS^{1,2}

BOARD THICKNESS (in.)	WALL CONSTRUCTION	MINIMUM FASTENER SIZE ³	MAXIMUM STUD SPACING (in.)	MAXIMUM FASTENER SPACING (in.)		ALLOWABLE SHEAR VALUE (plf)
				Edges	Field	
$\frac{1}{2}$	Unblocked	5d common nails	24	7	7	75
				4	4	110
$\frac{5}{8}$	Unblocked	6d common nails	24	4	4	145
$\frac{1}{2}$	Unblocked	No. 6 - $1\frac{1}{4}$ -inch screws	16	8	12	60
$\frac{1}{2}$	Blocked ⁴	No. 6 - $1\frac{1}{4}$ -inch screws	16	4	16	160
$\frac{1}{2}$	Blocked ⁴	No. 6 - $1\frac{1}{4}$ -inch screws	24	4	12	155
$\frac{1}{2}$	Blocked ⁴	No. 6 - $1\frac{1}{4}$ -inch screws	16	8	12	70
$\frac{1}{2}$	Blocked ⁴	No. 6 - $1\frac{1}{4}$ -inch screws	16	6	12	90
$\frac{5}{8}$	Unblocked	No. 6 - $1\frac{1}{4}$ -inch screws	16	8	12	70
$\frac{5}{8}$	Blocked ⁴	No. 6 - $1\frac{1}{4}$ -inch screws	16	8	12	90

For SI: 1 inch = 25.4 mm, 1 plf = 14.6 N/m.

¹Shear walls are not permitted to resist loads imposed by masonry or concrete construction. See UBC Section 2513.2 or Section 2306.4 of the IBC. Values are for short-term loading from wind or seismic forces. Values shall be reduced by 25 percent for normal loading. The values shall be reduced by 50 percent in UBC Seismic Zones 3 and 4. When used in conjunction with the IBC, the values shall be reduced by 50 percent in Seismic Design Category D. Values shall not be used in IBC Seismic Design Categories E and F.

²The shear values are permitted to be additive when identical materials applied as specified in the table are applied to both sides of the wall.

³Screws shall be Type W or Type S drywall screws.

⁴All board edges shall be blocked.

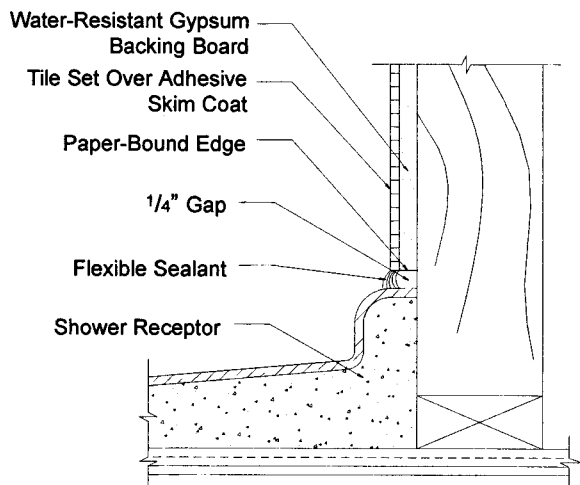
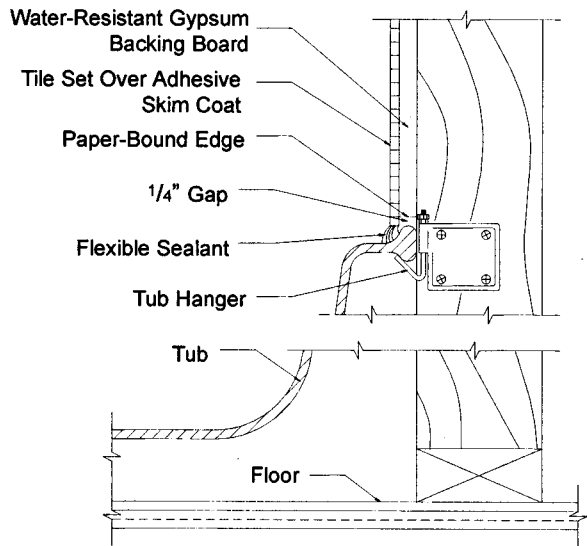
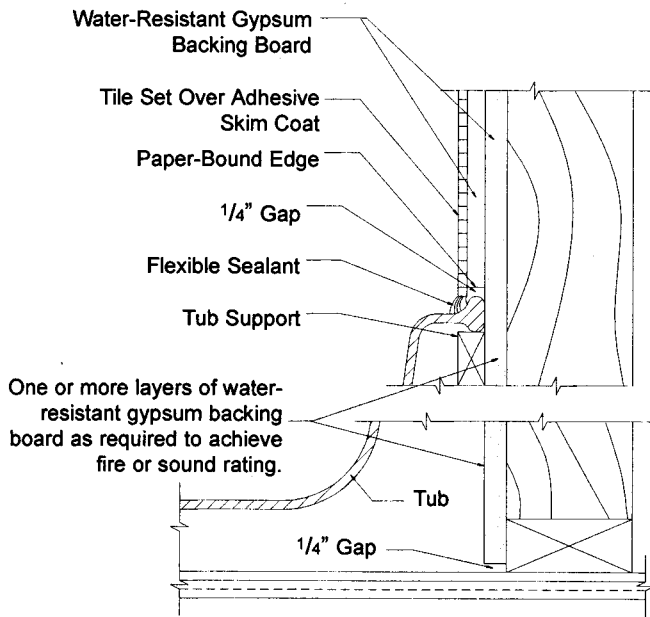
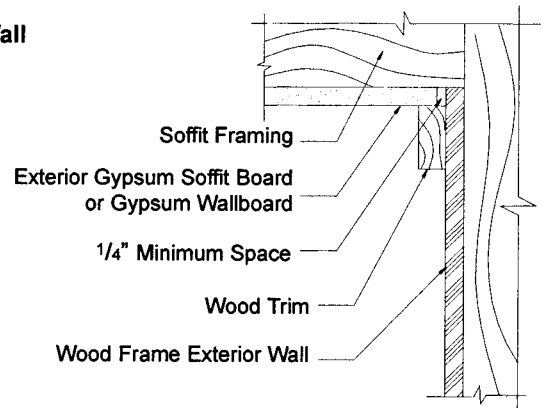
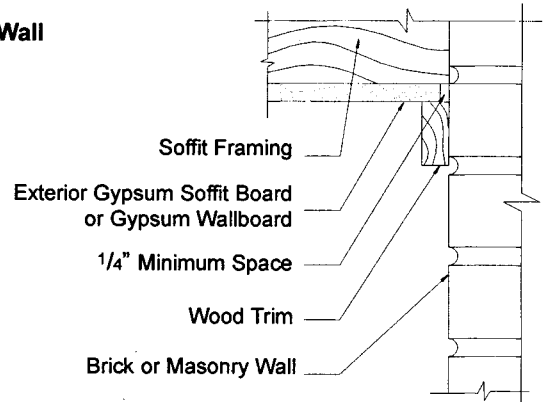

FIGURE 1—SHOWER AND BATH INSTALLATION DETAILS

Frame Wall



Masonry Wall



Alternate Fascia Details

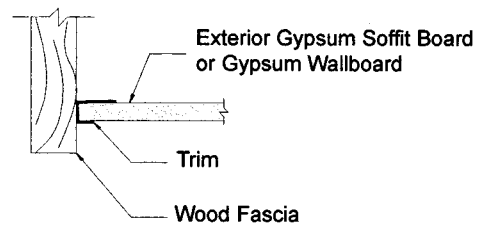
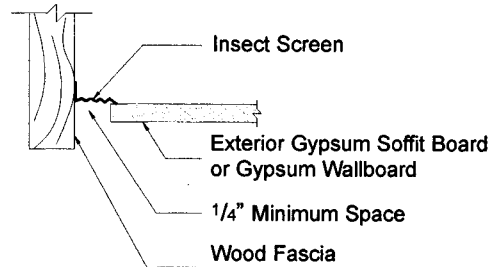

FIGURE 2—EXTERIOR SOFFIT DETAILS