

# ***Conventional Plaster Systems***



09 23 00

## Kal-Kore BRAND Plaster Base

### DESCRIPTION

Kal-Kore BRAND Plaster Base panels consist of a fire resistive gypsum core encased in blue absorptive face paper and liner paper on the back side. Although specifically designed as a base for veneer plaster, it also provides an excellent base for conventional basecoat plasters such as Gypsolite or Two-Way Hardwall.

### TECHNICAL DATA

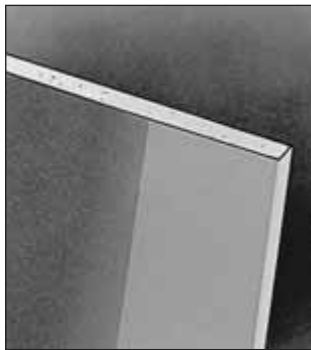

#### KAL-KORE PLASTER BASE

Kal-Kore is available in two basic types: Regular and Fire-Shield type X. Kal-Kore is 4' wide and is supplied in 8' through 16' lengths. Thicknesses are as follows:

Regular – 3/8" and 1/2".

Fire-Shield – 1/2" Fire-Shield C, 5/8" Fire-Shield, 5/8" Fire-Shield C, produced to meet ASTM C 1396.

Note: Installation of gypsum lath and metal lath shall be in accordance with ASTM C 841. Do not use 3/8" Kal-Kore plaster base with conventional basecoat plasters.

## Conventional Plaster Accessories\*

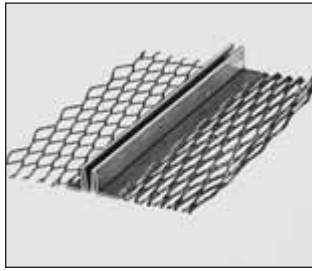

#### NO. 15 DOUBLE V EXPANSION JOINT

Minimizes cracking in large plaster areas. Also provides ground to ensure proper plaster thickness.

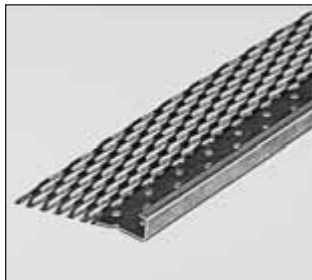

#### NO. 66 EXPANDED FLANGE SQUARE CASING

Has short, 90 degree return at plaster surface, serving as a plastering stop.

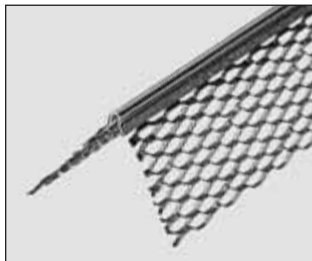

#### NO. 1 EXPANDED CORNERBEAD

The 2 1/2" expanded flange ends 1/4" from the nose of the bead providing reinforcement where needed most.

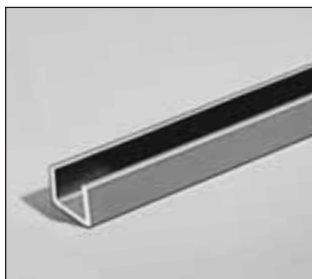

#### COLD ROLLED STEEL CHANNEL

Used as studs for attaching metal lath in 2" solid partitions. For furring or runners in suspended ceilings.

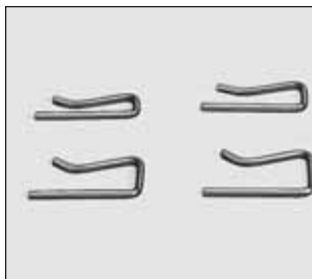

#### BEAM FURRING CLIP

Used to attach lath to flanges of steel beams, joists and columns. Tempered spring steel.

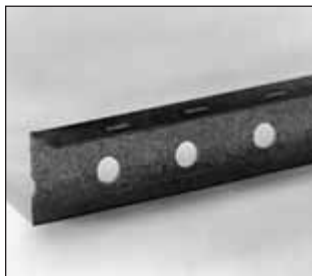

#### L RUNNER

Perforated – Ceiling or floor support for 2" solid lath and plaster partition.

Plain – Ceiling support for 2" solid board partition using 1" shaftliner.

## Metal Lath\*



#### DIAMOND MESH LATH

Used as a plaster base and reinforcement on almost all types of walls and ceilings, over wood or steel framing, flat or curved surfaces. Diamonds are 5/16" wide.

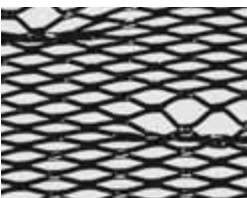

#### SELF-FURRING DIAMOND MESH LATH

Used extensively in stucco work, as a plaster reinforcement over interior masonry walls, and in steel column fireproofing. The self-furring dimples hold the metal lath 1/4" away from the surface to be plastered.



#### 1/8" FLAT RIB LATH

Designed to meet the demand for rigid expanded metal lath used as a plaster base in all types of work. Widely used as reinforcement for basecoat in ceramic tile work. Sheets are reversible.

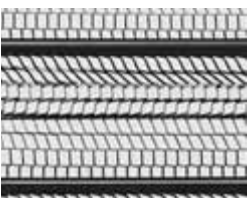

#### 3/8" RIB LATH

The 3/8" rib lath is used for ceilings under steel joist construction and metal reinforced concrete floors. It is also recommended for concrete slab floors over steel joists.

## DESCRIPTION

### GOLD BOND BRAND TWO-WAY HARDWALL GYPSUM PLASTER

Gold Bond BRAND Two-Way Hardwall Plaster is a basecoat plaster which requires the job site addition of an aggregate and water to provide working qualities and is designed for interior use over all accepted plaster bases. It may be applied by hand or used through pump/spray plastering machines.

#### ADVANTAGES

##### Controlled Uniformity

Two-Way Hardwall Plaster is set-stabilized and adjusted for market requirements and seasonal changes. When mixed with sand or other aggregate it has uniform working qualities and excellent spread.

#### Strength

Two-Way Hardwall Plaster properly proportioned with aggregate forms a hard, durable base for the finish coat. Its high tensile and compressive strength results in increased resistance to minor structural movements, impacts and abrasions.

#### Fire Resistance

Two-Way Hardwall Plaster is essentially mineral in composition and will not support combustion.

#### Specification Reference

ASTM Designation C 28, "Gypsum Plasters".

#### Bag Weight

100 lbs. (45.4 kg)

## TECHNICAL DATA

### AGGREGATE PROPORTION AND ESTIMATED COVERAGE

Aggregate Proportions	Plaster Base (Sq. M./Metric Ton)	Coverage, Sq. Yds. per Ton (161-203)	Sq. Ft. (Sq. M.) per Bag (7-9)	Thickness In. (mm)
Sanded 1:2-1/2	Gypsum Lath	175-220 (161-203)	80-100 (7-9)	7/16" (11.1)
	Metal Lath	90-125 (83-115)	40-55 (4-5)	9/16"* (14.3)*
Sanded 1:3	Brick & Clay Tile	175-220 (161-203)	80-100 (7-9)	9/16" (14.3)
	Concrete Block			

\*Measured from face of lath.

NOTE: Sanded 1:2-1/2 means 1 part plaster to 2-1/2 parts sand by weight.

### WEIGHT COMPARISON OF BASECOAT PLASTERS

Dry Set Mortar Weight	Sanded 1.3	Gypsolite Regular
Weight lbs. per cu. ft. (kg/m <sup>3</sup> )	120 (1922)	50 (801)
Lbs./yd. <sup>3</sup> (kg/m <sup>3</sup> ) 3/8" (9.5 mm) thick	34 (18)	14 (8)
Lbs./yd. <sup>3</sup> (kg/m <sup>3</sup> ) 1/2" (12.7 mm) thick	45 (24)	19 (10)
Lbs./yd. <sup>3</sup> (kg/m <sup>3</sup> ) 5/8" (15.9 mm) thick	56 (30)	24 (13)
Lbs./yd. <sup>3</sup> (kg/m <sup>3</sup> ) 3/4" (19.0 mm) thick	67 (36)	29 (16)
<b>Wet Mortar Weight</b>		
Weight lbs. per cu. ft. (kg/m <sup>3</sup> )	140 (2243)	69 (1105)

## DESCRIPTION

### GOLD BOND BRAND GYPSOLITE PLASTER

Gold Bond BRAND Gypsolite is a lightweight gypsum basecoat plaster mixed at the mill with correctly sized and proportioned perlite aggregate, requiring only the addition of water on the job. It is manufactured to be trowel-applied over gypsum or metal lath.

#### ADVANTAGES

##### Uniform Strength and Hardness

Uniformity is ensured through exact proportioning and thorough mixing of graded perlite and gypsum plaster at the mill. Gypsolite provides a uniform base for the finish coat.

##### Lightweight

Gypsolite weighs less than half as much as sanded gypsum plaster, thus reducing the dead-load on framing.

##### High Insulating Value

Gypsolite has a "k" factor of 1.5 which provides about 3 1/2 times the insulating value of sanded plaster.

## TECHNICAL DATA

### GYPSOLITE ESTIMATED COVERAGE

Plaster Base	Coverage, Sq. Yds. per Ton (Sq. M./Metric Ton)	Sq. Ft. (Sq. M.) per Bag (4-5)	Thickness In. (mm)
Gypsum Lath	140-155 (129-143)	50-55 (4-5)	7/16" (11.1)
Metal Lath	65-80 (60-74)	25-30 (2-3)	9/16"* (14.3)*

\*Measured from face of lath.

#### LIMITATIONS

When used over metal lath, a sand float finish should be specified. A smooth-trowel finish is not recommended since the combination of a relatively soft (perlite aggregated) basecoat and a hard (smooth-trowel lime/gauging) finish has the potential for cracking and spalling of the finish coat.

#### Fire Resistance

Gypsolite has excellent fire-resistive qualities and generally provides fire ratings higher than sanded plaster.

#### Specification Reference

ASTM Designation C 28 for "Gypsum Plasters".

#### Bag Weight

80 lbs. (36.3 kg)

25 lbs. (11 kg)

#### Water Ratio

1.2 gallons of water per 25 lbs. of plaster.



## PHYSICAL PROPERTIES OF BASECOAT PLASTERS (TYPICAL TEST RESULTS PER ASTM C 472)

Plaster Properties	Gypsolite Regular	Two-Way Hardwall						
		Gypsum Plaster to Sand by Weight			Gypsum Plaster and Vermiculite		Gypsum Plaster and Perlite	
		1:1	1:2	1:3	Regular	Masonry	Regular	Masonry
Mix	Mill Mix	1:1	1:2	1:3	100 lbs. (45.4 kg) 2 cu. ft. (.06 m <sup>3</sup> )	100 lbs. (45.4 kg) 3 cu. ft. (.08 m <sup>3</sup> )	100 lbs. (45.4 kg) 2 cu. ft. (.06 m <sup>3</sup> )	100 lbs. (45.4 kg) 3 cu. ft. (.08 m <sup>3</sup> )
Approximate Compressive Strength lbs. per sq. in. (kPa)	900 (6201)	1600 (11024)	1150 (7923)	750 (5168)	500 (3445)	300 (2067)	900 (6201)	650 (4479)
Approximate Tensile Strength lbs. per sq. in. (kPa)	160 (1102)	250 (1722)	190 (1309)	120 (827)	130 (896)	90 (620)	160 (1102)	100 (689)

## Finish Plasters

### DESCRIPTION

#### GOLD BOND BRAND GYPSUM GAUGING PLASTER (SUPER-WHITE)

Gold Bond BRAND Gauging Plaster, quick set or slow set type, is designed for use with finish lime. It is specially ground, calcined gypsum, which readily mixes with water and lime putty. Proper proportioning is essential, since gauging adds strength and hardness to the finish surface by reinforcing the plastic non-setting lime against shrinkage and cracking. A finish coat of gypsum gauging plaster and finish lime, job mixed 2 parts hydrated lime to 1 part plaster by weight, is designed primarily for interior smooth trowel application over a gypsum plaster basecoat. Smooth finish plasters should be applied at a thickness of not more than 1/16". Texture finishes should be applied at a thickness of not more than 1/8".

Complies with ASTM Designation C 28.

#### Bag Weight

Quick Set – 100 lbs. (45.4 kg) (50 lb. (22.7 kg) bags available in limited areas)

Slow Set – 100 lbs. (45.4 kg) (50 lb. (22.7 kg) bags available in limited areas)

### TECHNICAL DATA

#### GYPSUM GAUGING PLASTER

Method of Application	Coverage*
Trowel Finish	1000-1400 sq. yds./Ton (921-1290 m <sup>2</sup> /Metric Ton) 225-315 sq. ft./bag (21-29 m <sup>2</sup> /Bag)

\*With the addition of two tons of hydrated lime.

#### MILL-MIXED FINISH PLASTERS\*

Product	Method of Application	Coverage*
Kal-Kote Smooth Finish	Trowel	650-750 sq. yds./Ton (598-645 m <sup>2</sup> /Metric Ton)
Kal-Kote Texture Finish	Trowel	650-750 sq. yds./Ton (598-645 m <sup>2</sup> /Metric Ton)
Uni-Kal and X-KALibur	Trowel	600-665 sq. yds./Ton (553-613 m <sup>2</sup> /Metric Ton)

\*See page 46 for additional information.

#### GOLD BOND BRAND GYPSUM MOULDING PLASTER (SUPER-WHITE)

Gold Bond BRAND Moulding Plaster is a very white, finely ground gypsum, primarily used for all kinds of ornamental plaster work. Because of its low expansion, excellent strength and hardness, it is specially adaptable for casting in rubber, gelatin and other types of moulds. For casting purposes, only water is added. For run-in-place ornamental work, such as cornices, the moulding plaster is used with lime putty, mixed 2 parts lime to 1 part moulding plaster by weight.

Complies with ASTM Designation C 59.

#### Bag Weight

100 lbs. (45.4 kg) (50 lbs. (22.7 kg) available in limited areas)

Note: Application of plaster shall be in accordance with ASTM C 842.

#### Water Ratio

6.5 gallons of water per 100 lb. bag.

#### MILL-MIXED FINISH PLASTERS

For a mill-mixed finish plaster, use Kal-Kote Smooth Finish, Kal-Kote Texture Finish Plaster, Uni-Kal or X-KALibur Extended Set Veneer Plaster. Requires the addition of water only. See page 46.

#### GYPSUM MOULDING PLASTER

Method of Application	Coverage*
Trowel Finish	1000-1400 sq. yds./Ton (921-1290 m <sup>2</sup> /Metric Ton) 225-315 sq. ft./bag. (21-29 m <sup>2</sup> /Bag)

\*With the addition of two tons of hydrated lime.

#### PAINTING PLASTER

Various job conditions such as suction differences, wet or only partially dry walls, and reactions between paint and lime have caused unsatisfactory paint finishes, particularly on new construction.

Alkali-resistant primers specifically formulated for use over new plaster will permit decorating with oil or latex type paints.

Quality paint products should be used and manufacturers' recommendations followed. Finished plaster should be painted or covered to conceal possible discoloration. The paint system should be suitable for use over plaster surfaces that contain lime, which has a high pH of 10-13.

It is essential that plaster be sound and completely dry before painting. Conventional plaster may require 30 to 60 days to fully dry.



## DESCRIPTION

### ATTACHMENT OF GYPSUM PLASTER BASE TO HORIZONTAL AND VERTICAL WOOD SUPPORTS

Note: Application of Gypsum Plaster Base shall be in accordance with ASTM C 841.

Apply all Gypsum Plaster Base with long dimensions at right angles to the wood studs or supports. End joints shall occur on different supports in different courses and shall not be nearer than one full stud space from edges of openings in walls or partitions.

Gypsum Plaster Base shall be applied face side out and attached to wood framing with nails or staples.

Control joints should be installed in ceilings without perimeter relief with a maximum distance between such joints of 30' with a maximum undivided area of 900 sq. ft. With perimeter relief, maximum distance is 50' with maximum undivided area of 2500 sq. ft. On side walls control joints should be installed every 30'.

## TECHNICAL DATA

### MAXIMUM SPACING OF PLASTER BASE

Thickness of Plaster Base	Distance Between Supports	Number of Attachments per Bearing	Approximate Spacing c to c of Attachments
3/8" (9.5 mm)	16" (406 mm)	4	5" (127 mm)
1/2" (12.7 mm)	24" (609 mm)	4	5" (127 mm)

### NAILS AND STAPLES\* MINIMUM GAUGE REQUIREMENTS

Attachments	Thickness of Plaster Base	Length of Leg	Depth of Support Penetration	Diameter of Flat Head or Blued Nails or Crown Width of Staples*	Gauge of Shank of Nails or Staples*
Nails	3/8" (9.5 mm)	1 1/8" (28.6 mm)	3/4" (19.0 mm)	19/64" (7.5 mm)	13
Staples*		1" (25.4 mm)	5/8" (15.9 mm)	7/16" (11.1 mm)	16
Nails	1/2" (12.7 mm)	1 1/4" (31.8 mm)	3/4" (19.0 mm)	19/64" (7.5 mm)	13
Staples*		1 1/8" (28.6 mm)	5/8" (15.9 mm)	7/16" (11.1 mm)	16

\*Galvanized staples.

### 2" SOLID-METAL LATH CHANNEL STUD SYSTEM

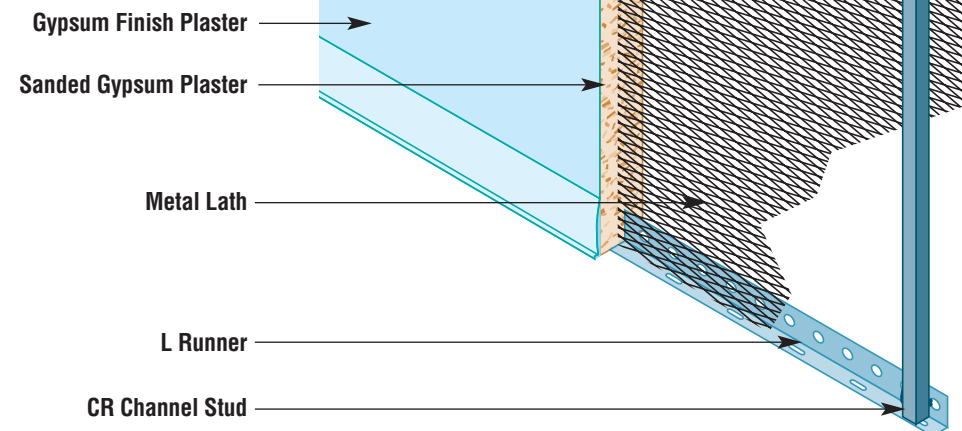

## DESCRIPTION

This partition with C.R. channel as studs gives fire protection, stability and sound insulation while occupying a minimum amount of floor and building space. The system consists of three metal units (channel stud, metal lath, L runners) which are used together with Diamond Metal Lath and Gypsum Plaster. These components form a space-saving, strong, non-load-bearing partition for use in interior wall construction.

### ADVANTAGES

#### Space Saving

Occupies less than half the space of conventional wood-stud or masonry constructed partitions.

#### Cost Saving

Simple erection cuts labor costs. One mechanic can quickly erect the channel studs and tie on Diamond Mesh Metal Lath.

#### Fire Protection

Composed of gypsum plaster and steel, it makes an excellent fire barrier. Official tests give the partition a one- to two-hour fire rating.

#### Sound Insulation

Partition is an effective sound barrier and has a Sound Transmission Class of 37 for 2" thick with sand, 33 for 2 1/2" thick with perlite aggregate.

### Strength

The completed partition is a monolithic slab of gypsum plaster thoroughly reinforced with expanded metal lath and securely anchored to floor and ceiling. It is highly resistant to tension, impact, shear and vibration.

### Adaptability

Partitions will accommodate door bucks of various types, casings, switch boxes and electrical outlets; also support lightweight fixtures such as kitchen cabinets.

### LIMITATIONS

Refer to table of Permissible Partition Heights on page 38.

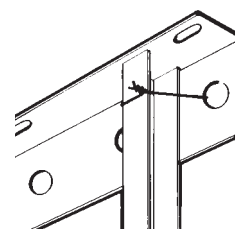

L RUNNER AT CEILING

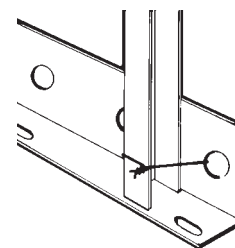

L RUNNER AT FLOOR

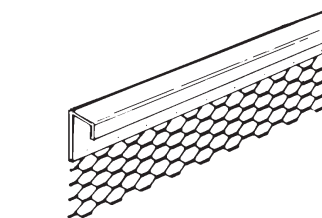

66 CASING BEAD

## TECHNICAL DATA

### SPACING OF VERTICAL SUPPORTS FOR ATTACHMENT

Type of Lath	Maximum Spacing of Supports	Weight Lbs. per Sq. Yd. (kg/m <sup>2</sup> )
Diamond Mesh Lath	16" (406 mm)	2.5 (0.6 kg)
Flat Rib Lath	16" (406 mm)	3.4 (1.9 kg)
3/8" (9.5 mm) Rib Lath	16" (406 mm)	2.75 (1.5 kg)
	24"* (610 mm)	3.4 (1.9 kg)

\*This spacing permissible for solid partitions not exceeding 16' (4877 mm) in height.

### PERMISSIBLE PARTITION HEIGHTS (BASED ON L/240)

Maximum Unsupported Height	Face-to-Face Plaster Thickness	Size and Weight of Channels (per 1000') (305 m)
12' (3658 mm)	2" (51 mm)	3/4" (19.0 mm) 300 lbs. (136 kg)
14' (4267 mm)	2 1/4" (57.2 mm)	3/4" (19.0 mm) 300 lbs. (136 kg)
16' (4877 mm)	2 1/2" (63.5 mm)	3/4" (19.0 mm) 300 lbs. (136 kg)
18' (5486 mm)	2 3/4" (69.9 mm)	1 1/2" (38.1 mm) 475 lbs. (215 kg)

## DETAILS

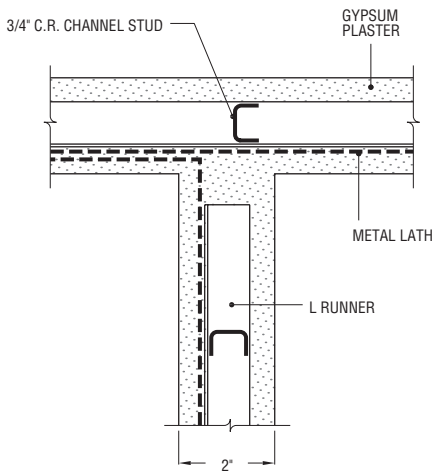

**INTERSECTING PARTITION**

09210A  
Scale: 3" = 1'-0"

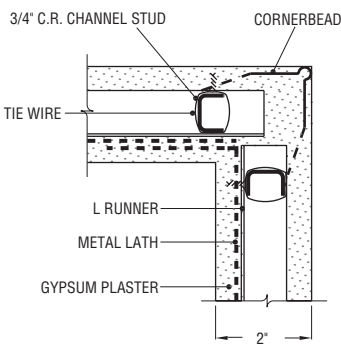

**CORNER DETAIL**

09210B  
Scale: 3" = 1'-0"

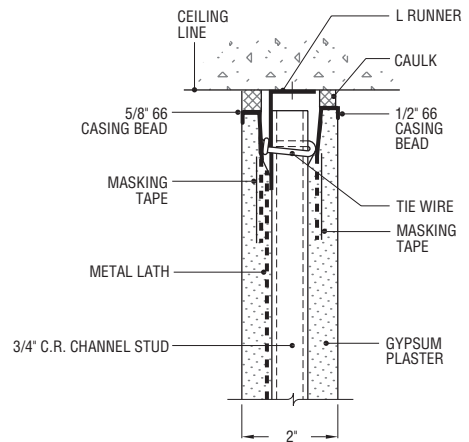

**CEILING DETAIL**

09210C  
Scale: 3" = 1'-0"

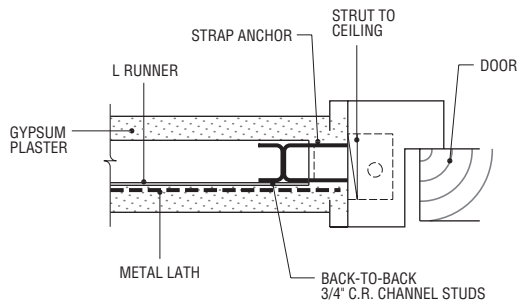

**METAL DOOR FRAME**

09210D  
Scale: 3" = 1'-0"

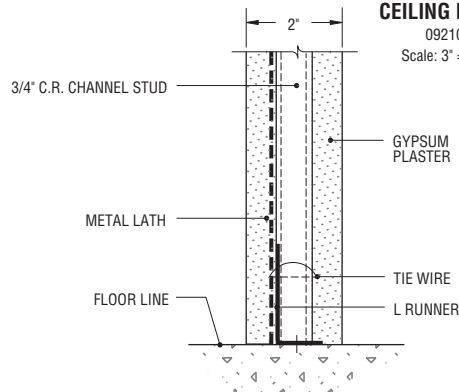

**BASE DETAIL**

09210E  
Scale: 3" = 1'-0"

# Fireproofing Columns and Beams with Metal Lath

## DESCRIPTION

Gypsum plaster, mixed with sand or lightweight aggregate, is applied over a metal lath base providing an economical fire protective covering for structural steel columns.

### ADVANTAGES

#### Lightweight

This system of fireproofing weighs only half as much as tile and one quarter as much as standard concrete for equivalent fire resistive ratings. This means a reduction of up to 1/3 in dead-load weight, reducing the size and cost of footings, foundations and structural framing.

#### Fire Resistance

Fire resistance ratings up to four hours can be obtained.

#### Economy

Lath is low in cost, quick and easy to apply, thereby effecting savings in material and labor costs.

### LIMITATIONS

In warehouses or other occupancies where columns might be damaged, angle iron guards are recommended to protect column corners to the necessary height.

## DETAILS

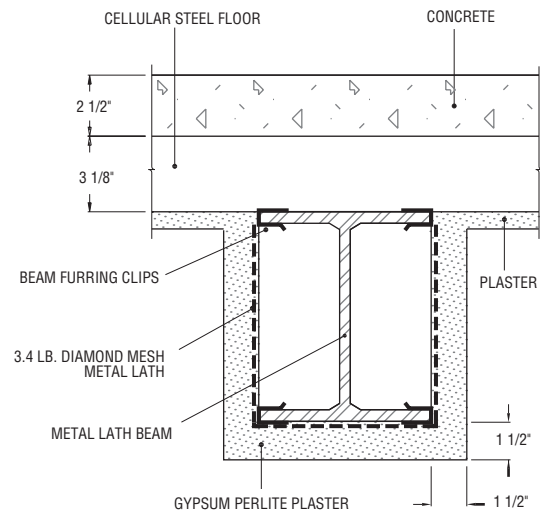

### BEAM-3 HOUR

09210J

Scale: 1 1/2" = 1'-0"

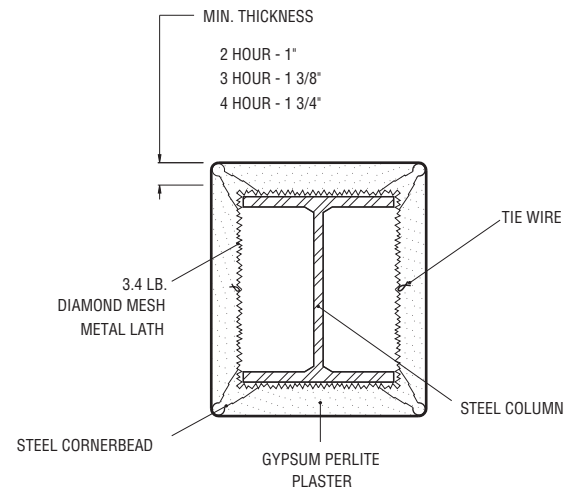
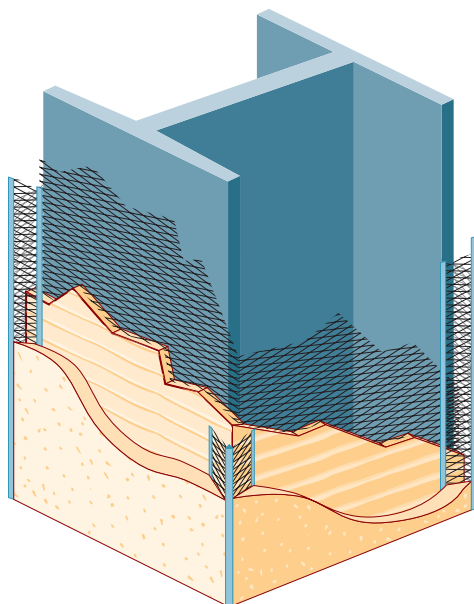

### COLUMN - UL X402

09210J1

Scale: 1 1/2" = 1'-0"

09 23 00

# Suspended Metal Lath Ceilings

## DESCRIPTION

Metal lath suspensions are commonly made below virtually all types of construction for fire-rated and non fire-rated plaster ceilings. Framing of 1 1/2" C.R. channels are spaced up to 4' o.c. perpendicular to joists and are cross-furred with 3/4" C.R. channels spaced according to specifications for types and weight of metal lath. Lath is then properly lapped at sides and ends and tied every 6" to the 3/4" channel.

Where it is advisable to install unrestrained ceilings, having perimeters separated from adjacent walls or partitions, galvanized casing beads

should be installed around the periphery. Metal Lath is frequently used for furred as well as suspended ceilings. Metal lath is used for furring from wood, concrete and steel joists.

### RECOMMENDATIONS

1. Control joints should be installed in ceilings without perimeter relief with a maximum distance between such joints of 30' with a maximum undivided area of 900 sq. ft. With perimeter relief, maximum distance is 50' with maximum undivided area of 2500 sq.ft.
2. Use three-coat plastering on metal lath.

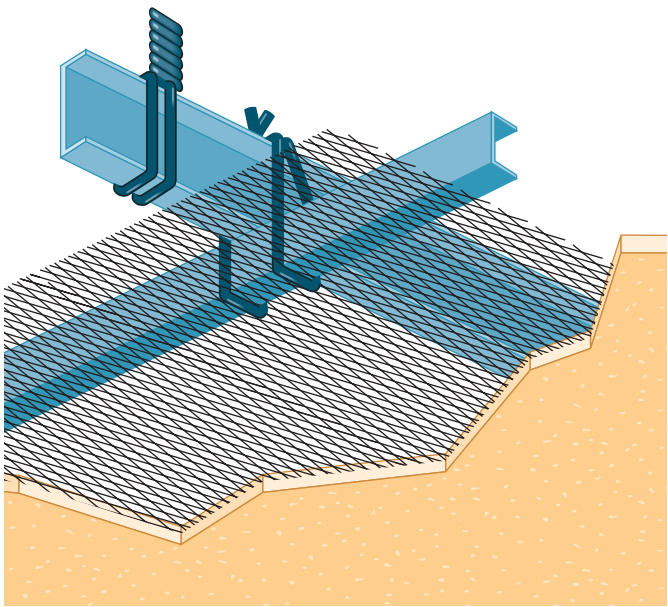

## TECHNICAL DATA

### SIZE AND SPACING OF CHANNEL FOR SUSPENDED CEILINGS

Center to Center Spacing of Hangers Along Channel	Size of Cold Rolled Channel	Main Channel (weight per 1000 ft.) (305 M)	Maximum Center to Center Spacing of Channel
up to 3' (914 mm)	1 1/2" (38.1 mm)	475 lbs. (216 kg)	4' (1219 mm)
up to 3'6" (1067 mm)	1 1/2" (38.1 mm)	475 lbs. (216 kg)	3'6" (1067 mm)
up to 4' (1219 mm)	1 1/2" (38.1 mm)	475 lbs. (216 kg)	3' (914 mm)

### SIZE AND SPACING OF CHANNEL FOR FURRED AND SUSPENDED CEILINGS

Center to Center Spacing of Hangers	3/4" (19.0 mm) C.R. Channel Cross Furring 300 lbs. (136 kg)/1000 ft. (305 M)	Maximum Furring Spacing
up to 3' (914 mm)	3/8" (9.5 mm) rib lath	24" (610 mm)
up to 3' (914 mm)	3.4 lb. (1.5 kg) flat rib lath	19" (483 mm)
up to 3'6" (1067 mm)	3.4 lb. (1.5 kg) mesh lath	16" (406 mm)
up to 4' (1219 mm)	2.5 lb. (1.1 kg) mesh lath	12" (305 mm)

### MAXIMUM SPACING OF SUPPORTS FOR METAL LATH

Type of Lath	Support Spacing	Weight of Lath lbs. per sq. yd. (kg/m <sup>2</sup> )
Diamond Mesh (flat expanded)	16" (406 mm)	3.4 (1.9)
Flat Rib	16" (406 mm)	2.75 (1.5)
	19" (483 mm)	3.4 (1.9)
3/8" (9.5 mm) Rib	24" (610 mm)	3.4 (1.9)

## DETAILS

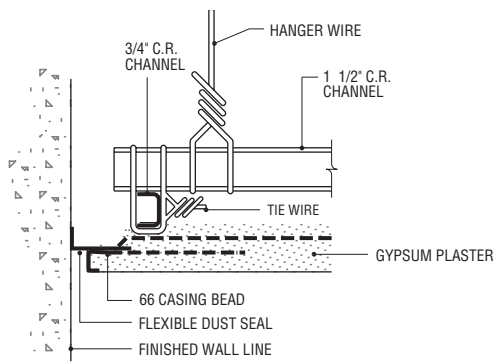

**SUSPENDED METAL LATH AT WALL (UNRESTRAINED)**  
09210K  
Scale: 3' = 1'-0"

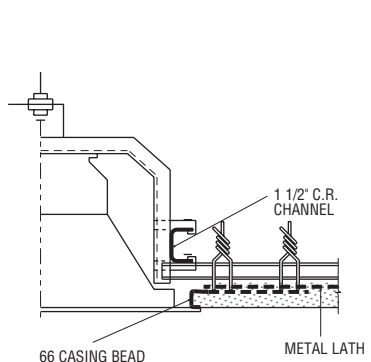

**LIGHTING TROFFER**  
092100  
Scale: 1 1/2' = 1'-0"

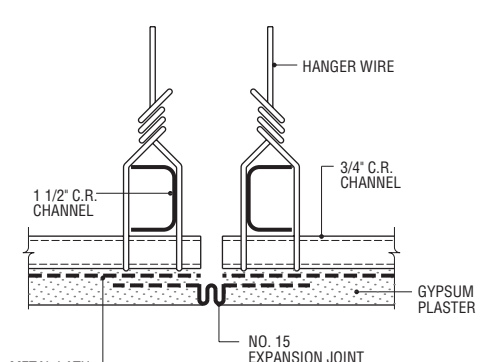

**SUSPENDED METAL LATH CONTROL JOINT**  
09210M  
Scale: 3' = 1'-0"

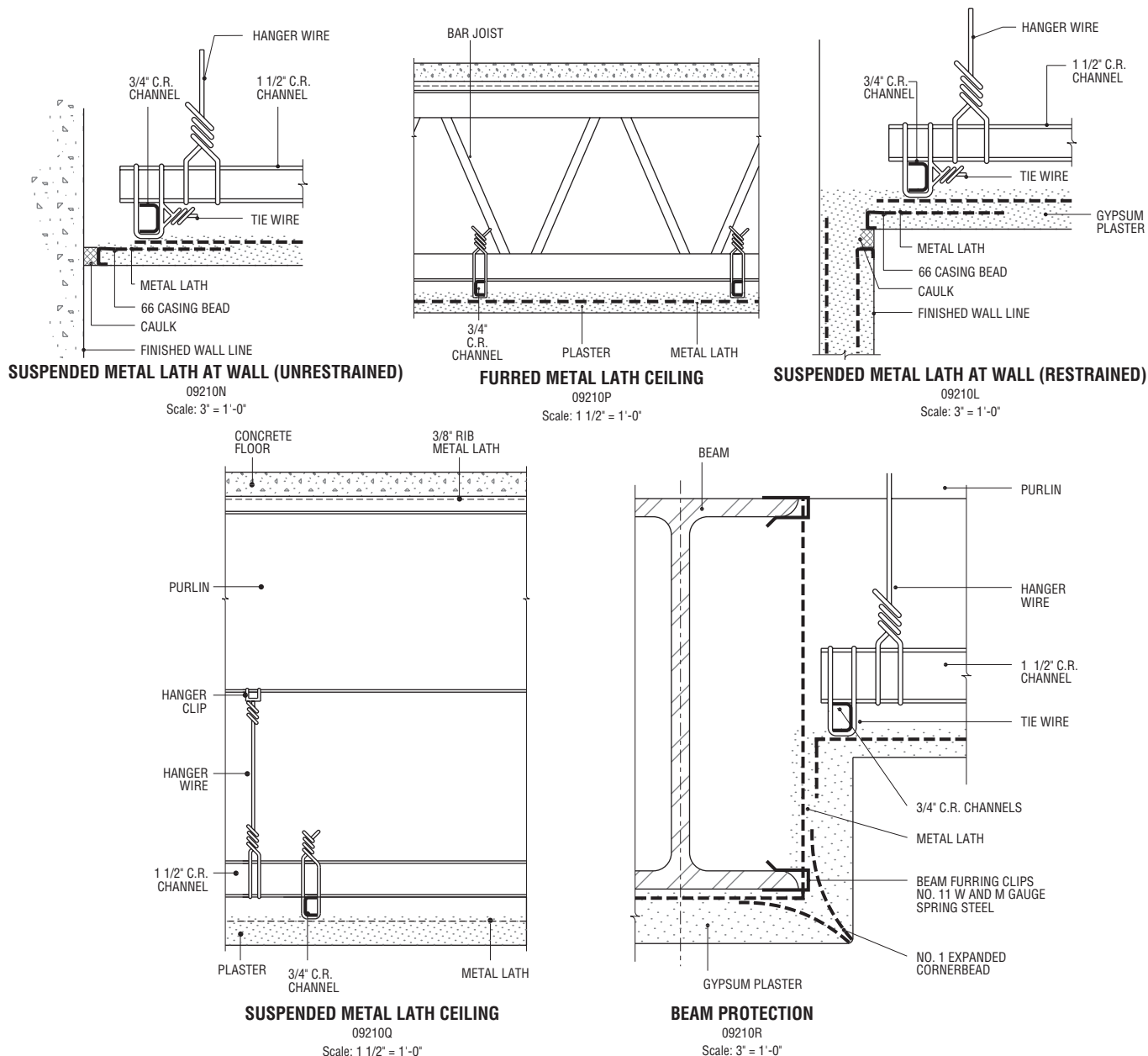

**SPECIFICATIONS**

**SECTION 09 23 00**

**GYPHUM PLASTERING**

THE FOLLOWING PARAGRAPHS ARE FOR INSERTION INTO SECTIONS OF GENERIC SPECIFICATIONS OR GENERIC/PROPRIETARY SPECIFICATIONS COVERING GYPHUM PLASTER PRODUCTS. THE NATIONAL GYPHUM COMPANY PRODUCT NAME FOLLOWS THE GENERIC DESCRIPTION IN PARENTHESES.

**PART 1 GENERAL**

**1.02 REFERENCES**

- A. American Society for Testing and Materials (ASTM):
  1. C 28, Specification for Gypsum Plasters.
  2. C 59, Specification for Gypsum Casting and Molding Plaster.
  3. C 1396, Specification for Gypsum Board (Gypsum Base for Veneer Plaster).

- 4. C 841, Specification for Application of Interior Lathing and Furring.
- 5. C 842, Specification for Application of Interior Gypsum Plaster.

**PART 2 PRODUCTS**

**2.02 MATERIALS**

A. Gypsum Plaster Base:

1. Regular: A gypsum core lathing board surfaced with absorptive paper on front, and long edges and complying with ASTM C 1396 (Kal-Kore BRAND Plaster Base).
  - a. Thickness: 1/2"
  - b. Width: 4'
  - c. Length: 8' through 16'
  - d. Edges: Tapered

09 23 00

2. Fire-Resistant: A gypsum core lathing board with additives to enhance the fire resistance of the core and surfaced with absorptive paper on front, and long edges and complying with ASTM C 1396, Type X.
    - a. Thickness: 1/2" (Kal-Kore BRAND Fire-Shield C Plaster Base) or 5/8" (Kal-Kore BRAND Fire-Shield and Fire-Shield C Plaster Base).
    - b. Width: 4'
    - c. Length: 8' through 16'
    - d. Edges: Tapered
  3. Regular, Foil-Backed: A gypsum core lathing board surfaced with absorptive paper on front, and long edges; backed with aluminum foil; and complying with ASTM C 1396 (Kal-Kore BRAND Foil-Back Plaster Base).
    - a. Thickness: 1/2"
    - b. Width: 4'
    - c. Length: 8' through 16'
    - d. Edges: Tapered
- B. Gypsum Plaster:
1. Base Plaster: Gypsum neat plaster complying with ASTM C 28 (Gold Bond BRAND Two-Way Hardwall Gypsum Plaster).
  2. Base Plaster: Gypsum plaster with mill-mixed perlite aggregate complying with ASTM C 28 (Gold Bond BRAND Gypsolite Plaster).
  3. Finish Plaster: Gypsum gauging plaster complying with ASTM C 28 (Gold Bond BRAND Super-White Gauging Plaster Quick Set and Gold Bond BRAND Super-White Gauging Plaster Slow Set).
  4. Finish Plaster: Gypsum moulding plaster complying with ASTM C 59 (Gold Bond BRAND Super-White Moulding Plaster).
  5. Finish Plaster: Gypsum plaster for smooth finish complying with ASTM C 587 (Kal-Kote BRAND Smooth Finish Plaster).
  6. Finish Plaster: Gypsum plaster for textured finish complying with ASTM C 587 (Kal-Kote BRAND Texture Finish Plaster).
  7. Finish Plaster: Gypsum plaster for smooth finish complying with ASTM C 587 (Uni-Kal BRAND Veneer Plaster).
  8. Finish Plaster: Gypsum plaster for smooth finish with extended set time complying with ASTM C 587 (X-KALibur BRAND Veneer Plaster).

## PART 3 EXECUTION

### 3.01 INSTALLATION

- A. Metal Lath, Gypsum Plaster Base, and Accessories: In accordance with ASTM C 841.
- B. Gypsum Plaster: In accordance with ASTM C 842 and the manufacturer's recommendations, National Gypsum Company "Gypsum Construction Guide."
- C. Tolerances: For flatness of surface, do not exceed 1/4" in 8' for bow or warp of surface and for plumb and level.

## RECOMMENDATIONS

### BASECOAT PLASTER PROCEDURES

#### Two-Coat Work

Apply first coat with firm pressure to form good bond on the Gypsum Plaster Base or masonry base; then immediately double back (without cross-raking first coat) using material of same proportion to build proper basecoat thickness. Straighten to a true surface (without applying water) to receive the second (finish) coat.

Surface should be left sufficiently rough and porous to provide suitable bond of the finish coat.

#### Three-Coat Work

"Scratch" – "brown" – finish is generally used for metal lath or masonry bases, and is performed in discrete steps.

- Scratch (first) coat: Should be applied with sufficient material and pressure to obtain good bond over solid bases or form full keys through metal lath. Provide suitable material thickness for scratching (raking) to obtain good mechanical keying of the "brown" coat.
- Brown (second) coat: Shall be applied after the scratch (first) coat has set hard and still damp. Apply to give mass and surface as for double-back in two-coat work.

### Finish Coat Plaster Procedures

#### General Requirements (Basecoat Condition)

Application over a partially dry basecoat is preferred. If basecoat is thoroughly dry, wet with even application of water to a semi-dry condition. Avoid excess water. Do not apply finish to basecoats having free water on the surface.

#### Application – Gauged Lime Putty Trowel Finish

##### Smooth Finishes

- Scratch in tightly over the basecoat, covering the surface completely, then double back immediately with material from the same gauge, filling out to a true, even surface with total thickness of not more than 1/16".
- Allow finish to "draw" (lose moisture to basecoat and ambient air) and firm up – then trowel it well to compact and close the surface under the edge of the trowel. Dash water on the surface for lubrication and development of soft material along trowel's edge to fill surface depressions or other blemishes.
- When finish plaster setting action is under way, a second (final) water troweling can be done with strong pressure to obtain a polished surface if desired.

##### Texture Finishes

- Apply finish as above to a true, even surface with total thickness not more than 1/8".
- Allow finish to "draw" (lose moisture to basecoat and ambient air). Then begin floating, texturing, or skip troweling to achieve desired texture. Additions of clean graded silica may be required to achieve desired texture.

##### Drying

Conventional plaster systems should be allowed to dry 30 days minimum under ambient conditions prior to final decoration. Variances in humidity or poor drying conditions may affect the drying process.

##### Storage

Gypsum plaster must be kept dry before use. Storage conditions vary with location and seasonal changes, which may affect storage life. These conditions may affect product characteristics such as setting time, working qualities, component separation, or lumping, etc. Such aging is normally a function of exposure to humid air, temperature, and physical support in warehousing. Adverse storage conditions or prolonged storage may affect the working qualities of the product. Rotate inventory frequently for best results.



For additional information  
Phone 1-800-NATIONAL  
(1-800-628-4662)