



**JL INDUSTRIES**

**FLOOR GRATINGS  
AND MATS**



**Division 12 48 13**  
**Entrance Floor Mats  
and Frames**

**Division 12 48 19**  
**Entrance Floor Gratings**

**ACTIVAR**  
INC.

[www.activar.com](http://www.activar.com)

**Construction Products Group**



JL INDUSTRIES



AIR  
LOUVERS



SAMSON PRODUCTS



THOMAS  
ENTERPRISES



HIAWATHA

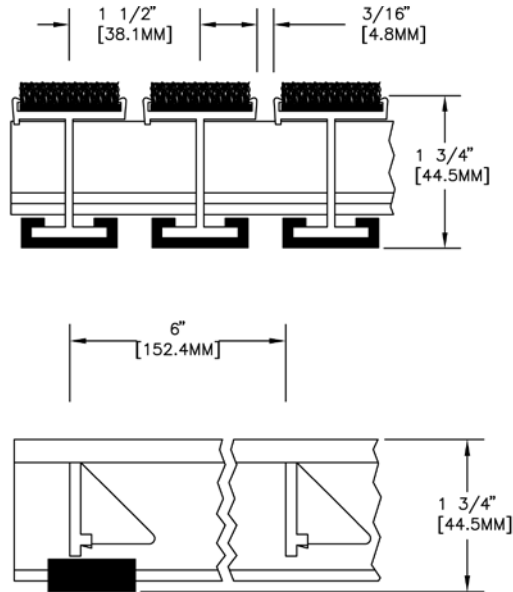

**JL-900-909 SERIES**



## RIGID ALUMINUM GRATINGS FOR HIGH TRAFFIC AREAS

- **Gratings Remove Easily for Cleaning**
- **3/16" Rail Spacing Prevents the Smallest Heel from Catching, yet Allows Dirt and Sand to Collect Below the Surface**
- **6" Keylock Spacing is Quieter and Stronger than 8", 10", Welded or Bolted Systems**
- **Wide Selection of Durable and Colorful Treads**
- **1500 lb. Wheel Load Capacity**

## TREAD OPTIONS FOR THE 900 SERIES ALUMINUM GRATINGS

**JL-900:** Carpet

**Rail Finish:** Any Color

**Frame:** 900 Series Frame Options

**LEED:** 46

**JL-901:** Vinyl

**Rail Finish:** Any Color

**Frame:** 900 Series Frame Options

**LEED:** 46

**JL-902:** Serrated Aluminum Surface

Meets NFPA 258 standards, NFPA 253 and FTM Standard 372

**Rail Finish:** Clear

**Frame:** 900 Series Frame Options

**LEED:** 50

**JL-903:** Abrasive-Coated Aluminum

**Rail Finish:** Clear only

**Frame:** 900 Series Frame Options

**LEED:** 44

**JL-904:** Abrasive-Coated Vinyl

**Rail Finish:** Any Color

**Frame:** 900 Series Frame Options

**LEED:** 44

**JL-905:** Tuff Tread

**Rail Finish:** Any Color

**Frame:** 900 Series Frame Options

**LEED:** 46

**JL-907:** Premium Carpet

**Rail Finish:** Any Color

**Frame:** 900 Series Frame Options

**LEED:** 46

**JL-909:** Buffed Rubber Inserts

**Tread Color:** Grey, other colors additional charge

**Rail Finish:** Any Color

**Frame:** 900 Series Frame Options

**LEED:** 44

### #1 Specify Tread Option

### #2 Specify Tread Color from page 8

### #3 Specify Rail Finish Color from Rail & Frame Finish Colors

### #4 Specify Frame Style from 900 Series Frame Options Chart

### #5 Find LEED Rating on page 7

## RAIL AND FRAME FINISH COLORS

|                |  |              |  |
|----------------|--|--------------|--|
| Mill           |  | Light Bronze |  |
| Clear Anodized |  | Black        |  |
| Dark Bronze    |  | Medium Gold  |  |
| Medium Bronze  |  | Champagne    |  |



**ALUMINUM GRATINGS FOR HIGH TRAFFIC ENTRYWAYS**

- Gratings Remove Easily for Cleaning
- 1/8" Rail Spacing Prevents the Smallest Heel from Catching, yet Allows Dirt and Sand to Collect Below the Surface
- Stronger and Quieter than 8" Spacer, Welded or Bolted Systems
- 1500 lb. Wheel Load

**JL-906S (SERRATED) & JL-906P (SMOOTH) TOP RAIL SURFACE GRATING:  
Thin Line 3/4" O.C. Rails**

Extruded full-length serrated tread 5/8" (15.9mm) wide. Keylock bars are spaced 3" (76.2mm) on center with extruded vinyl cushions spaced 24" (609.6 mm) on center. Meets NFPA 258 standards, NFPA 253 and FTM Standard 372.

**Rail Finish:** Mill  
**Frame:** 900 Series Frame Options  
**LEED:** 50  
**EQ Credit 5:** Indoor Chemical & Pollutant Source Control

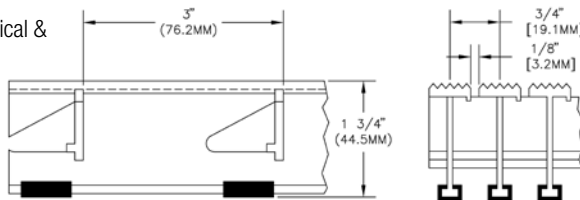
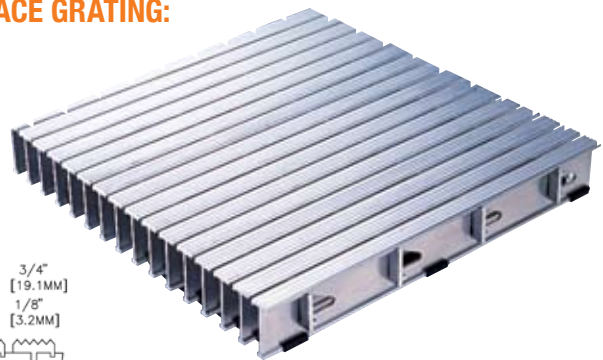

**FRAME OPTIONS: 900 Series**

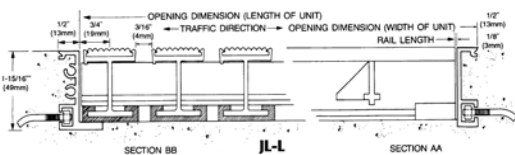

**JL-L:** Recessed level-bed frame—1500 lbs./ft.<sup>2</sup> uniform load, 1 15/16" (49.2mm) deep by 1/2" (12.7mm) profile aluminum alloy. Available in any color frame.

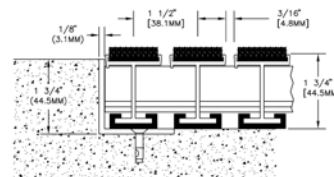

**JL-LAF:** Recessed angle frame—1500 lbs/ftw uniform load, 1-3/4" (44.5mm) deep by 1/8" (3.2mm) profile aluminum extrusion. Available in any color frame.

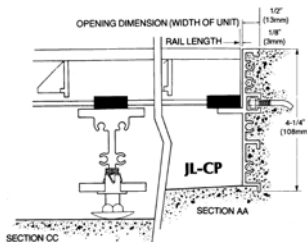

**JL-CP:** Concrete Pit—recessed pit with adjustable cross-supports 300 lbs./ft.<sup>2</sup> uniform load (higher loads available), 4-1/4" (108mm) by 1/2" (12.7mm) profile aluminum alloy with adjustable cross-supports 4" O.C.

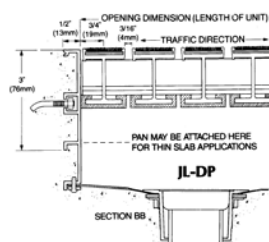

**JL-DP JL-CP:** Recessed concrete pit frame with aluminum drain pan. 4-1/4" (108mm) by 1/2" (12.7mm) profile aluminum alloy with adjustable cross-supports 4" O.C. Available in any color frame. Drain pan is mill aluminum.

# 700 & 800 SERIES

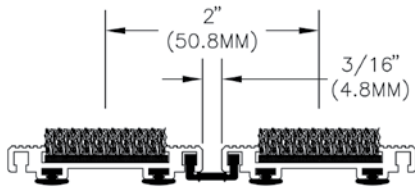

**JL-700 SERIES**

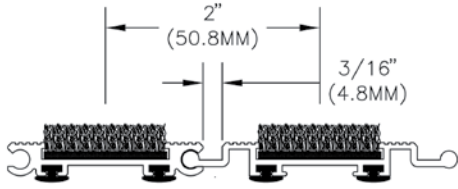

**JL-800 SERIES**



## LOWEST PROFILE ALUMINUM ROLL-UP MAT WITH LOW-NOISE LDPE HINGE DESIGN: 700 SERIES

- Most Economical Entry Mat System
- Recycled LDPE Hinges
- Hinge System Eliminates the Clatter Associated with Metal Hinge Systems
- 350 lb. Uniform Load Capacity
- Any Color Frame and Rail Finish

## INTEGRAL ALUMINUM HINGE DESIGN: 800 SERIES

- 3/8" Profile
- Effective for Custom-Fabricated Applications
- Any Color Selection for Rail Tread Finish
- Integral Aluminum Hinge System is More Durable than Plastic Hinge Systems
- 350 lb. Uniform Load Capacity

## TREAD INSERT OPTIONS: 700 & 800 Series

**JL-700:** Carpet  
**LEED:** 50

**JL-701:** Vinyl  
**LEED:** 59

**JL-702:** Serrated Aluminum  
Meets NFPA 258 standards,  
NFPA 253 and FTM  
Standard 372  
**LEED:** 41.47

**JL-703:** Abrasive-Coated  
Aluminum  
**LEED:** MR4.1, 4.2" 52%

**JL-704:** Abrasive-  
Coated Vinyl  
**LEED:** D

**JL-705:** Tuff Tread  
**LEED:** 50

**JL-707:** Premium Carpet  
**LEED:** 50

**JL-709:** Buffed-Rubber  
**LEED:** 10

**JL-800:** Carpet inserts  
**LEED:** 49

**JL-801:** Vinyl inserts  
**LEED:** 37

**JL-804:** Abrasive-  
Coated Vinyl  
**LEED:** 46

**JL-805:** Tuff Tread  
inserts  
**LEED:** 49

**JL-807:** Premium  
Carpet inserts  
**LEED:** 49

- #1 Specify Tread Option
- #2 Specify Tread Color from page 8
- #3 Specify Rail Finish Color from Rail and Frame Finish Colors
- #4 Specify Frame Style from 700/800 Series Frame Options Chart
- #5 Find LEED Rating on Page 7

## RAIL AND FRAME FINISH COLORS

|                |  |              |  |
|----------------|--|--------------|--|
| Mill           |  | Light Bronze |  |
| Clear Anodized |  | Black        |  |
| Dark Bronze    |  | Medium Gold  |  |
| Medium Bronze  |  | Champagne    |  |

## FRAME OPTIONS: 700 & 800 Series

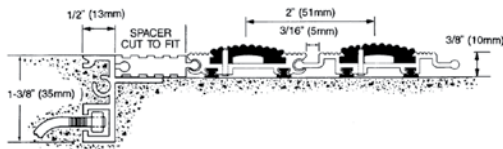

**JL-R:** Recessed frame that allows the mat to rest flush with the floor surface. 1-3/8" (34.9mm) deep by 1/2" (12.7 mm) profile. Available in any color frame.



**JL-TR:** Recessed angle frame for butting up to tile or carpet. 7/16" (11.1mm) deep by 1/8" (3.2mm) profile. Available in any color frame.

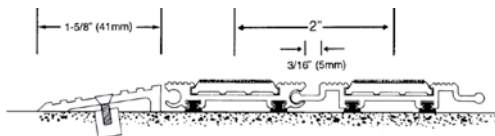

**JL-SA:** Surface mounted aluminum frame for permanent installation. 3/8" (9.5mm) deep by 1-5/8" (41.3 mm) wide profile. Serrated aluminum alloy extrusions. Available in any color frame.

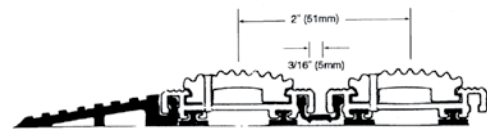

**JL-SV:** Surface mounted vinyl frame for a moveable installation. 3/8" (9.5 mm) deep by 1-5/8" (41.3 mm) wide profile. Available in Black Serrated flexible black plastic only.



**LOW PROFILE ALUMINUM ROLL-UP GRATING FOR HEAVY WHEEL LOADS**

- **3/4" Deep Profile**—Ideal for Building Renovations
- **Designed for up to 1500 lb. Wheel Loads**—Ideal for Heavy Cart Traffic
- **LEED 44 Rating on All Models Except 609**
- **Continuous Bottom Cushions Reduce Noise**

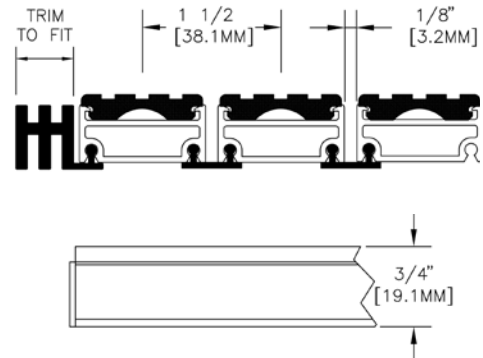

**TREAD INSERT OPTIONS:**

- JL-600:** Carpet
- JL-601:** Vinyl
- JL-604:** Vinyl-abrasive
- JL-605:** Tuff Tread
- JL-607:** Premium Carpet
- JL-609:** Buffed Rubber Inserts
- Frame:** JL FA Frame Only
- LEED:** MR 4.1, 4.2: 44%, EQ 5: (JL-609)

**FRAME OPTIONS: 600 Series**

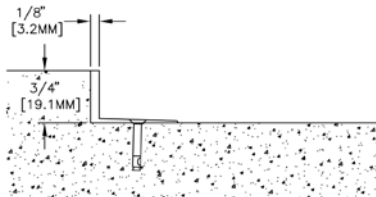

**JL-AA:** Recessed angle frame. 3/4" (25.4mm) deep by 1/8" (3.2mm) wide aluminum extrusion. Available in any color frame.

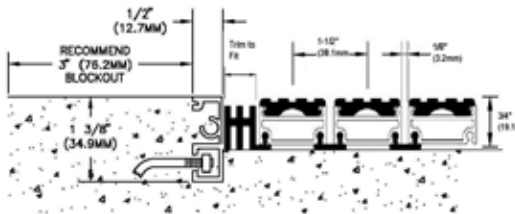

**JL-A:** Level bed frame allows grate to rest directly on the recessed concrete. 1-3/8" (34.9 mm) deep by 1/2" (12.7mm) profile. Available in any color frame.

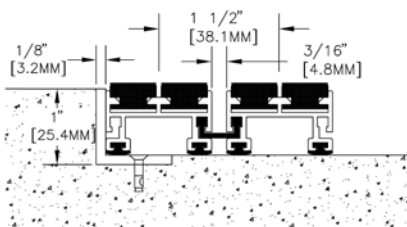

**JL-FA:** Recessed angle frame for the Model JL609 Buffed Rubber Tread Only. Aluminum frame 1" (25.4mm) deep by 1/8" (3.2mm) wide aluminum alloy extrusion. Available in any color frame.



- #1 Specify Tread Option
- #2 Specify Tread Color from page 8
- #3 Specify Rail Finish Color from Rail & Frame Finish Colors
- #4 Specify Frame Style from 600 Series Frame Options Chart
- #5 Find LEED Rating on page 7

**RAIL AND FRAME FINISH COLORS**

|                |  |              |  |
|----------------|--|--------------|--|
| Mill           |  | Light Bronze |  |
| Clear Anodized |  | Black        |  |
| Dark Bronze    |  | Medium Gold  |  |
| Medium Bronze  |  | Champagne    |  |



## STAINLESS STEEL GRATING FOR HIGH TRAFFIC ENTRYWAYS

- Resistance-welded .093" x 0.156" Stainless Steel Wire Construction
- .14" (3.6mm) Rail Spacing Allows Water, Snow and Dirt to Fall Through
- #4 Satin Stainless Steel Finish
- Support Bars spaced 1" apart for the Greatest Load Capacity
- 1000 lb. rolling and uniform load (JL-98DPSS 300 lb load)
- Designed for Very Heavy Foot or Light Vehicle Traffic
- Anchored by Hidden Lockdowns
- EQ credit 5 Indoor Chemical & Pollutant Source Control: Minimum Size Req'd.
- MR Credit 4.1, 4.2 Recycled Content: 18% pre-consumer, 72% post consumer.

### TREAD INSERT OPTIONS:

**JL-503:** 7/16" deep grate

**Surface-Mounted Installations:** JL-38SM frame

**Recessed Installations:** JL-38SS, JL-38AL

**JL-508:** 5/8" deep grate

**Recessed Installations:** JL-58SS, JL-58AL

**JL-509:** 9/8" deep grate

**Recessed Installations:** JL-98AL

**Stainless Steel Deep Pit:** JL 98SSDP



### FRAME OPTIONS: 500 Series

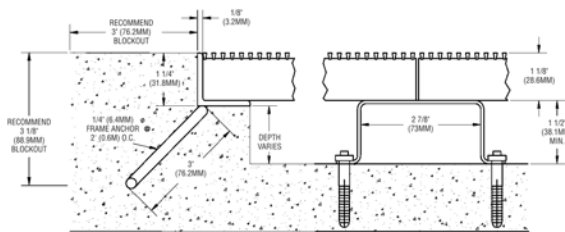

**Deep Pit Stainless Recessed Frame for 509:** JL-98SSDP (Pan Optional)

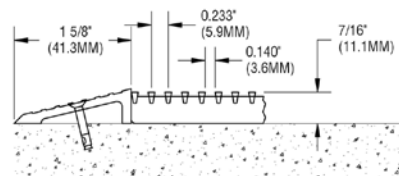

**Surface-Mounted Permanent Installation Frame:** JL-38SM  
7/16" (9.5 mm) deep by 1-5/8" (41.3 mm) wide profile.  
Serrated aluminum extrusion angle.

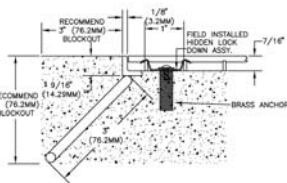

#### Stainless Steel Level Bed Recessed Frame.

JL-38SS—9/16" deep (JL-503)  
JL-58SS—3/4" deep (JL-508)  
JL-98SSLB—1-1/4" deep (JL-509)  
Anchored by Hidden Lockdowns  
Aluminum Frames also Available  
See 500 Series on website

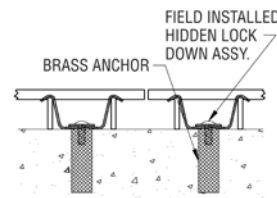

**Intermediate Anchoring System**  
Required for all Models.



## LEED™ RELATED DATA

The Leadership in Energy and Environmental Design (LEED) Green Building Rating System™ is the nationally accepted benchmark for the design, construction and operation of high-performance green buildings. LEED gives building owners and operators the tools they need to have an immediate and measurable impact on their buildings' performance. LEED promotes a whole-building approach to sustainability by recognizing performance in five key areas of human and environmental health: sustainable site development, water savings, energy efficiency, materials selection and indoor environmental quality.

### LEED: 59

#### MR Credits 4.1, 4.2: Recycled Content

This model contains a minimum of 59% pre-consumer recycled content. Note that most aluminum has an actual post-consumer recycled content that is much higher, but at this time it is not possible to guarantee post-consumer recycled content for a specific batch or project.

### LEED: 50

#### MR Credits 4.1, 4.2: Recycled Content

This model contains a minimum of 50% pre-consumer recycled content. Note that most aluminum has an actual post-consumer recycled content that is much higher, but at this time it is not possible to guarantee post-consumer recycled content for a specific batch or project.

### LEED: 49

#### MR Credits 4.1, 4.2: Recycled Content

This model contains a minimum of 49% pre-consumer recycled content. Note that most aluminum has an actual post-consumer recycled content that is much higher, but at this time it is not possible to guarantee post-consumer recycled content for a specific batch or project.

### LEED: 46

#### MR Credits 4.1, 4.2: Recycled Content

This model contains a minimum of 46% pre-consumer recycled content. Note that most aluminum has an actual post-consumer recycled content that is much higher, but at this time it is not possible to guarantee post-consumer recycled content for a specific batch or project.

### LEED: 44

#### MR Credits 4.1, 4.2: Recycled Content

This model contains a minimum of 44% pre-consumer recycled content. Note that most aluminum has an actual post-consumer recycled content that is much higher, but at this time it is not possible to guarantee post-consumer recycled content for a specific batch or project.

### LEED: 41.47

#### MR Credits 4.1, 4.2: Recycled Content

This model contains a minimum of 41.47% pre-consumer recycled content. Note that most aluminum has an actual post-consumer recycled content that is much higher, but at this time it is not possible to guarantee post-consumer recycled content for a specific batch or project.

### LEED: 37

#### MR Credits 4.1, 4.2: Recycled Content

This model contains a minimum of 37% pre-consumer recycled content. Note that most aluminum has an actual post-consumer recycled content that is much higher, but at this time it is not possible to guarantee post-consumer recycled content for a specific batch or project.

### LEED: 15.61

#### MR Credits 4.1, 4.2: Recycled Content

This model contains a minimum of 15.61% pre-consumer recycled content. Note that most aluminum has an actual post-consumer recycled content that is much higher, but at this time it is not possible to guarantee post-consumer recycled content for a specific batch or project.

### LEED: 12.66

#### MR Credits 4.1, 4.2: Recycled Content

This model contains a minimum of 12.66% pre-consumer recycled content. Note that most aluminum has an actual post-consumer recycled content that is much higher, but at this time it is not possible to guarantee post-consumer recycled content for a specific batch or project.

### LEED: 10

#### MR Credits 4.1, 4.2: Recycled Content

This model contains a minimum of 10% pre-consumer recycled content. Note that most aluminum has an actual post-consumer recycled content that is much higher, but at this time it is not possible to guarantee post-consumer recycled content for a specific batch or project.

## EQ CREDIT 5: Indoor Chemical and Pollutant Source Control

This product is intended for permanent installation. To meet this credit's requirements for an entryway system, size product at least six feet in the traffic direction and maintain the product properly.

## WARRANTY:

JL Industries warrants all Floor Gratings, Mats and Frames of the 600, 700, 800 or 900 Series for a period of two years from date of shipment against defects in material or workmanship. The 500 Series products constructed of stainless steel are warranted for five years from date of shipment. In addition to the above, the following Tread Inserts carry a 5 year warranty against defects in material or workmanship, but not wear; Tuff Tread; Premium Carpet, Buffed Rubber. The liability of JL is strictly limited to the repair or replacement of units that, in our opinion, were properly installed and subsequently found defective. No claims for consequential damages of any nature will be allowed. This warranty is in lieu of all other warranties, expressed or implied.

# TREAD INSERT COLOR OPTIONS



**PREMIUM CARPET TREAD:** Our most absorbent and extremely durable carpet tread is designed to clean shoes and hold up to 1.5 gallons of water and 13.4 pounds of dirt per square yard. Constructed of 100% polyamide fastened to a rubber/vinyl compound backing and mechanically secured to tread rails, this 35 oz. carpet meets some of the most stringent requirements in the industry. Colorfast and solution dyed—provides lower life cycle costs than standard carpet.

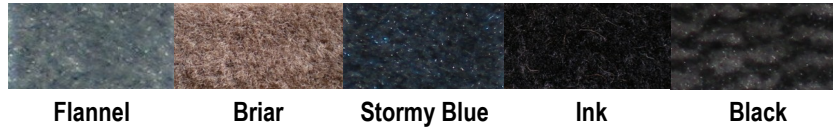

**TUFF TREAD® EXTRA HEAVY-DUTY CARPET TREAD:** One of our 2 solutions for high-traffic entrances—does not absorb moisture and stands up to weather. Constructed of widely-spaced, crimped, polypropylene fibers that are large, stiff, chisel-shaped and widely spaced, that are bonded to the backing and mechanically secured to tread rails. Colorfast and solution dyed—provides lower life cycle costs than standard carpet.



**STANDARD CARPET TREAD:** Our high quality carpet tread is designed for interior use. Constructed of 100% woven nylon bonded to the backing and mechanically secured to tread rails, this 28 oz. carpet is available in a wide range of colors. Colorfast and solution dyed.



**VINYL TREAD:** Use this waterproof tread with continuous striations for high-traffic, wet exterior or interior entryways. Constructed of extruded vinyl (colors) or extruded rubber (black), tread is mechanically secured to tread rails.

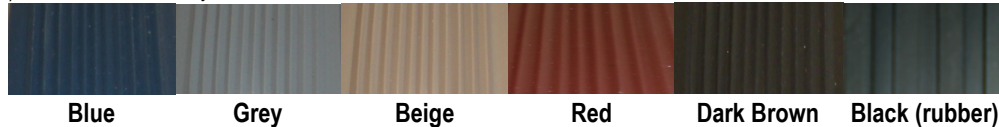

**VINYL ABRASIVE TREAD:** Use this waterproof tread with factory-applied abrasive grit that gives extra friction for high-traffic, wet exterior or interior entryways. Constructed of abrasive grate, tape-bonded to a rigid bio-based /recycled plastic tread insert that is mechanically secured to tread rails.



**ALUMINUM TREAD WITH ABRASIVE COATING:** Use this waterproof tread where slip resistance is important in wet exterior or interior entryways. Aluminum oxide grit is embedded in a two-part epoxy coating to aluminum treads. Rails are provided with integral extruded aluminum tread.

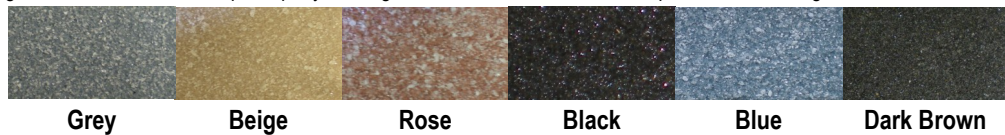

**BUFFED RUBBER TREAD:** Two buffed rubber treads per rail stand up to years of heavy wear, even in extremely high traffic areas.



Select from 8 Tread Types—Please See Individual Product Pages to Determine Which Treads are Available for Each Frame

HEADQUARTERS & MANUFACTURING :4450 WEST 78<sup>TH</sup> ST CIRCLE, BLOOMINGTON, MN 55435-5416  
 PH: 800-554-6077 FAX: 952-835-2218 EMAIL: SALES@JLINDUSTRIES.COM WWW.ACTIVARCPG.COM  
 ACPG SOUTHEAST (THOMAS ENTERPRISES): FT MYERS, FL ACPG WEST COAST (SAMSON PRODUCTS): COMMERCE, CA  
 ACPG WAREHOUSES: DALLAS TX, LANCASTER PA, ATLANTA GA , SEATTLE WA, CHICAGO IL EM1009 REV 9-27-12