



INSTALLATION INSTRUCTIONS

Attach **FutureFlash®** around all windows in order to protect against leaks caused by soaking and wind driven rain. FutureFlash® is comprised of a strong outer film with rubberized asphalt core which seals around nails and staples.

DESCRIPTION

FutureFlash® is a prefabricated waterproofing membrane designed for use around windows and doors under stucco and other exterior wall systems. The product may be used to strip in the flanges of wood, metal and vinyl windows or as a flashing wherever a uniform, dependable waterproofing barrier is required. FutureFlash® is constructed of two high-performance films with a core of rubberized asphalt sandwiched between them. The outer laminated polyethylene film is tough and tear-resistant. The polyester film layer adds dimensional stability to the product. FutureFlash® is engineered to be the strongest, most dependable waterproofing system available to withstand extreme jobsite conditions.

FutureFlash® is attached using nails, staples, screws and other conventional fastening methods. The rubberized asphalt core self-seals around fasteners to eliminate leaks. FutureFlash® must be adhered to the building paper using the approved FutureFlash® Sealant™. This process effectively incorporates the window into the building system and protects the structure from water damage caused by soaking or wind-driven rain, snow and ice.

INTENDED USES

FutureFlash® is designed for "Exterior openings exposed to the weather shall be flashed in such a manner as to make waterproof." FutureFlash® provides protection from leaks in structures of all types and may be used to weatherproof windows, doors, vents, etc.

INSTALLATION

1. Install gray side out with black side against substrate.
2. Attach to studs using nails, screws or staples.
3. Do not expose to direct sunlight for more than 60 days.
4. FOLLOW INSTALLATION DIAGRAMS ON REVERSE.

Window Flashing Instructions

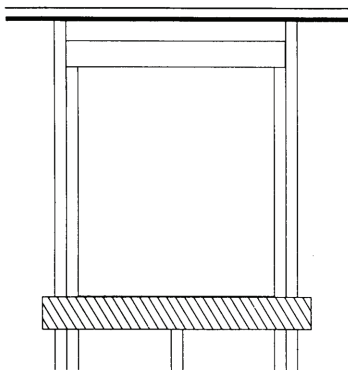

STEP 1—

Attach FutureFlash® horizontally to sill plate and extend flashing 6" past left and right vertical king studs.

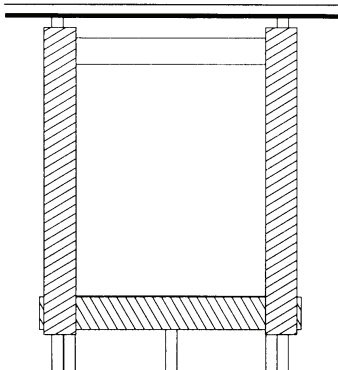

STEP 2—

Attach FutureFlash® vertically to left and right king studs, extending flashing 6" below sill plate line to overlap sill flashing. Flashing should extend 6" above bottom of header beam to ensure proper lapping for next step.

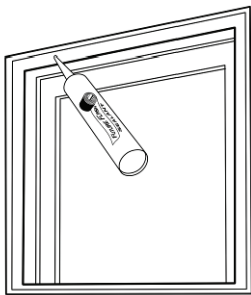

STEP 3—

Before window is set, apply a generous bead ($3/8$ "- $1/2$ ") of sealant to the back side of the window nailing flange before setting window into flashed window opening.

FUTURE FLASH™

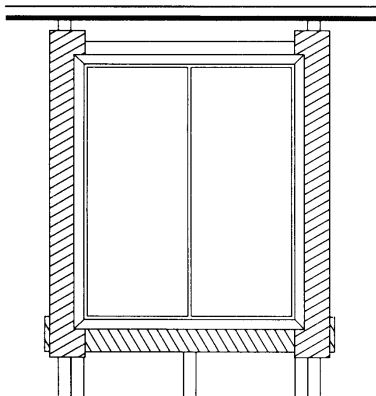

STEP 4—

Set window in opening, level and attach. After the window is in place, apply a second generous bead of sealant over the transition seam of the window nailing flange and flashing and tool flat.

STEP 5—

Attach FutureFlash® horizontally to header beam extending flashing 6" past left and right vertical king studs. Flashing will lap over horizontal exterior window flange at the top of the window frame.

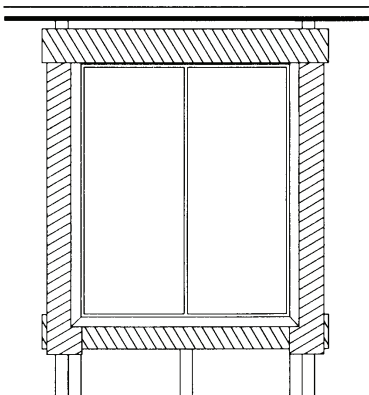

TECHNICAL DATA

PROPERTY	ASTM	Result
Thickness	D 5147	25 mils min.
Tear Strength	D 1938	44.7 lbs/in
Tensile Strength	D 412	31.5 lbs/in
Elongation	D 412	129%
Pliability	D 146	Pass, -10 F
Roll Length	---	75'
Roll Width	---	6", 9", 12", 18", 36"

FutureFlash® as been tested by an independent lab and is listed under ICC-ES ER-2783

LIMITED 10-YEAR WARRANTY

MFM Building Products Corp. (MFM) warrants materials to be free from leaks caused by defects in material or manufacturing for a period of ten (10) years from the date of purchase when applied according to published directions and will, at its option, resupply or refund the purchase price of any materials proven to be defective. Misapplication or poor workmanship is specifically excluded under the terms of this warranty. MFM shall be liable for no additional remedies, hereby expressly denying any other claims for damages, whether direct or indirect, consequential or incidental, including but not limited to property damage, personal injury to the buyer or to a third party and loss of business or profit arising from the use or inability to use the product. Any implied warranties arising under state law are limited to the duration and terms of this express warranty.



BUILDING PRODUCTS CORP.

P.O. Box 340

Coshocton, OH 43812

Toll-free: (800) 882-7663

Telephone: (740) 622-2645

Fax: (740) 622-6161

www.mfmbp.com