

5-Year
Warranty

Proudly Made in
the U.S.A.



ADA SOLUTIONS, INC.
DETECTABLE WARNING SURFACES
FOR PEDESTRIAN CROSSINGS

RADIUS TACTILE

**CAST-IN-PLACE REPLACEABLE (WET-SET)
OR SURFACE MOUNT**



*Service, Delivery and Price
Make ADA Solutions, Inc. the Obvious Choice*

WWW.ADATILE.COM • 800-372-0519

US Patents*
[*www.adatale.com/patents](http://www.adatale.com/patents)



RADIUS TACTILE

**CAST-IN-PLACE REPLACEABLE (WET-SET)
OR SURFACE MOUNT**

*Proudly Made in
the U.S.A.*

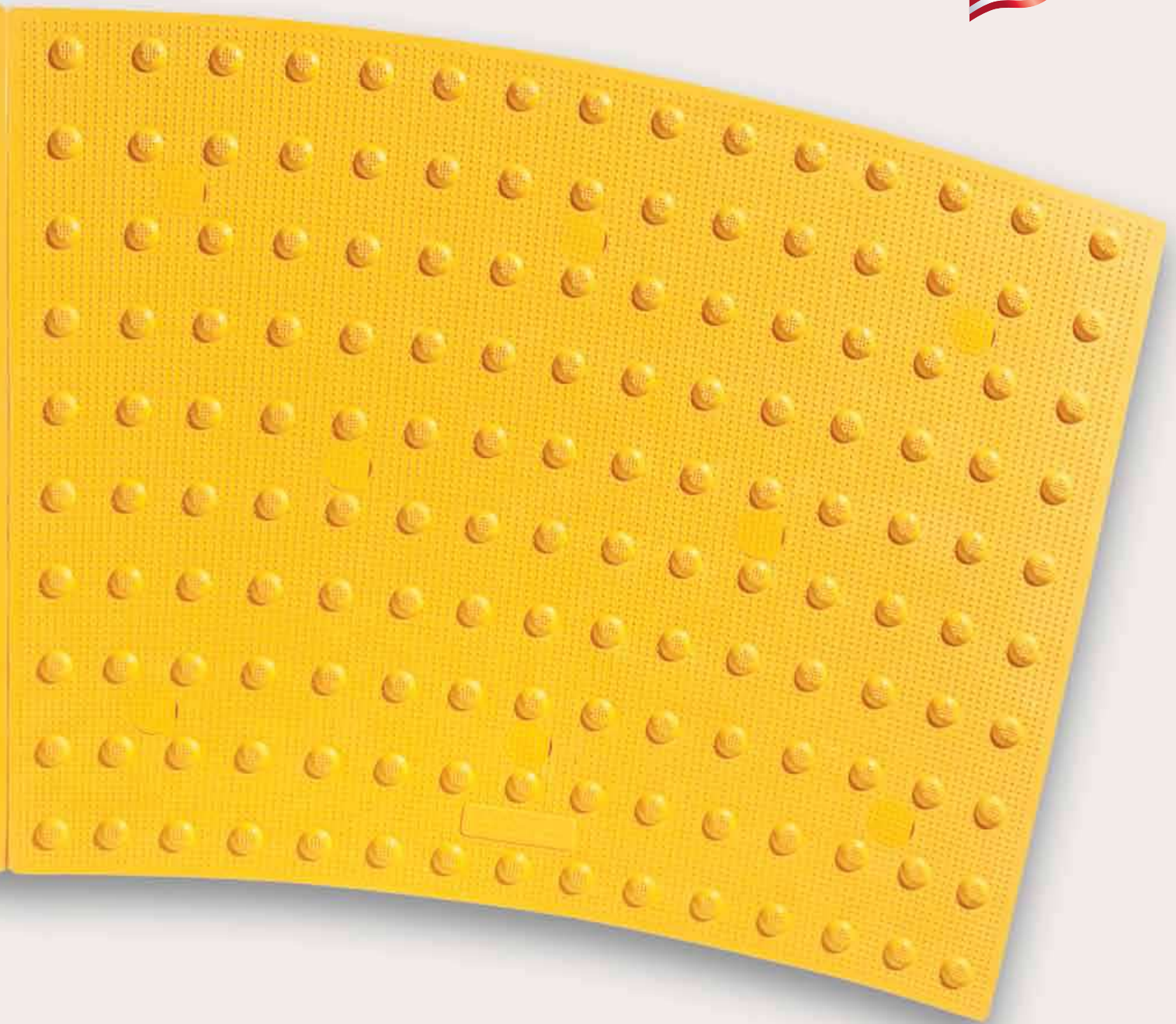

In stock colors

Safety Red
31350

Dark Gray
36081

Brick Red
20109

Black
37038

Clay Red
22144

Yellow
33538



RADIUS TACTILE - REPLACEABLE

Installation Procedure

Be sure to read and understand all of these instructions before you begin.

A. The physical characteristics of the concrete shall be as specified in the contract documents while maintaining a slump range of 4-7 inches to permit the solid placement of the ADA Replaceable Tactile Unit (ADAREP) in the wet cement.

B. The concrete shall be poured and finished level, true and smooth to the required dimensions prior to the placement of the ADAREP unit.

C. Working in a grid pattern, tamp the ADAREP unit into the wet concrete using a rubber mallet and a piece of wood. Continue this process until all of the air has been released, and the ADAREP unit surface is flush with the surrounding area.
IMPORTANT: Avoid striking the surface of the ADAREP unit directly.

D. Following the placement, the ADAREP unit elevation should be checked to the adjacent surface with a straight edge. The ADAREP unit elevation should be consistent with the Contract Drawings and Specifications. Any required adjustments must be made prior to the time when the concrete begins to set.

E. **IMPORTANT NOTICE TO INSTALLER:** *To allow for expansion and contraction, after tile is installed, use a 1/4" finish edge trowel around entire perimeter. On a continuous run, be sure to space each unit 1/8" apart.*

F. When you are confident that the ADAREP unit is in place and no further adjustments are needed, place a cinder block on both ends to hold the ADAREP unit in place while the concrete sets.

G. During and after the ADAREP unit installation, as well as the concrete curing stage, no walking or external forces can be placed on the ADAREP unit. The area must be protected from pedestrian traffic until concrete is cured. The ADAREP Warning Surface will be ready for pedestrian traffic within 2-4 hours.

H. Be sure to remove plastic protective covering from the face of the ADAREP Unit once the concrete is cured.

*Not recommended or warranted for asphalt installation.

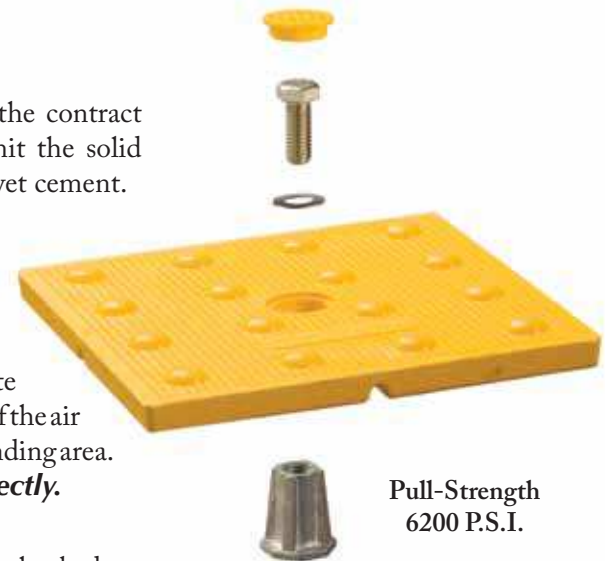

PRODUCT SIZES
2' x 33 1/4"

APPLICATION
Fresh Pour
Concrete Ramps
& Replacement

*View additional photos, drawings and specifications
on our website: www.adatile.com.*

Call (800) 372-0519 with any questions.

RADIUS TACTILE - REPLACEABLE

(WET-SET)

Replacement Procedure

Be sure to read and understand all of these instructions before you begin.

- A.** Lift the existing composite bolt cap from each anchor location on the ADA Replaceable Tactile unit (ADAREP) with a flat head screw driver.
- B.** Remove the existing 1/2" x 1 1/2" heavy duty steel bolts and washers from each anchor location on the ADAREP unit with a ratchet. Save & reuse.
- C.** Tap around all sides of the ADAREP unit and across the middle with a rubber mallet, working in a grid pattern.
- D.** Pry the existing ADAREP unit from the concrete ramp with a small prybar, working around the edges until it can be lifted cleanly away.
- E.** Be sure to remove all small debris and dust from the existing impression in the concrete ramp.
IMPORTANT: Be careful not to get debris into anchor locations.
- F.** Replace new ADAREP unit into impression in concrete ramp. Lightly tamp down the ADAREP unit with a rubber mallet and a piece of wood. Continue this process until the ADAREP unit is set firmly into existing impression in concrete ramp.
IMPORTANT: Avoid striking the ADAREP unit directly.
- G.** Bolt existing 1/2" x 1 1/2" heavy duty steel bolts and washers back into each anchor location on new ADAREP unit.
- H.** Snap a new composite bolt cap provided, into each anchor location on the ADAREP unit. The ADAREP unit is ready for pedestrian traffic immediately after installation is complete.



**View additional photos, drawings and specifications on our website: www.adatale.com.
Call (800) 372-0519 with any questions.**

US Patents*
***www.adatale.com/patents**

RADIUS TACTILE - REPLACEABLE

Inline Dome Pattern

DOMES GEOMETRY

ADAAG, PROWAG and ADA/ABA Compliant in-line truncated dome pattern.

UNIVERSAL RADIUS TWS PRODUCT

Universal Radius TWS Product is scored for a 10', 15' and 20' radial condition and may be cut by a table saw to accommodate site conditions.

RADIUS PANEL SIZES

ADA Replaceable TWS Unit: 24" x 33¼", 8 recessed and capped ½" x 1½" bolts with concrete inserts and heavy duty perimeter detail.

MATERIAL

A durable exterior grade homogenous glass, carbon and fiberglass reinforced composite material which is colorfast and UV stable. The color of the ADAREP unit is uniform throughout and does not rely on any type of paint coating to achieve color stability. Standard colors include: Federal Yellow, Brick Red, Clay Red, Safety Red, Dark Gray and Black. For superior wheelchair, walker and shopping cart mobility, truncated domes have a center-to-center (horizontally and vertically) spacing of 2.35 inches.

PHYSICAL CHARACTERISTICS

Compressive Strength	28,900 psi	ASTM D 695
Flexural Strength	29,300 psi	ASTM D 790
Slip Resistance	1.18 Dry, 1.05 Wet	ASTM C 1028
Chemical Stain Testing	No Deterioration	ASTM D 543
Abrasion Resistance	549	ASTM C 501
Accelerated Weathering	Delta E<5.0 (2,000 hours)	ASTM G 155
Tensile Strength	11,600 psi	ASTM D 638
Load Bearing at 16,000#	No Damage	AASHTO-H20
Freeze/Thaw/Heat	No Disintegration	ASTM C 1026

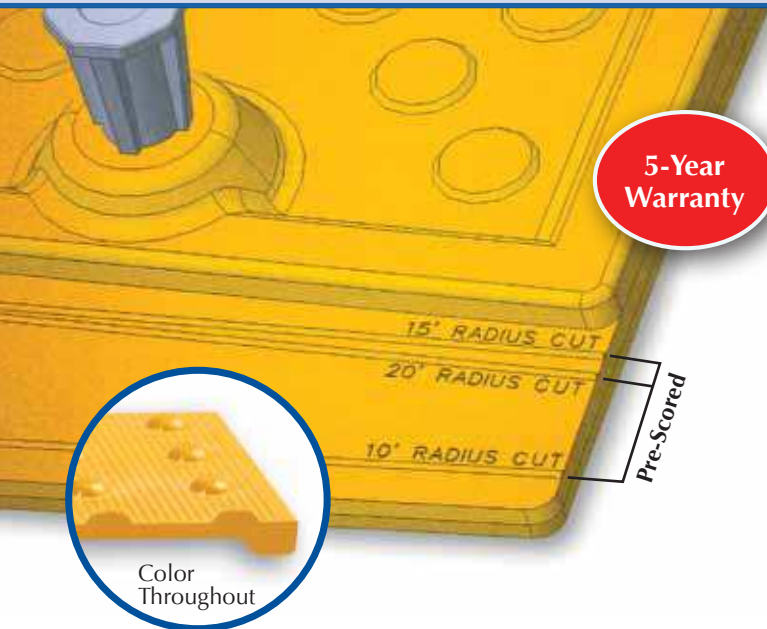

INSTALLATION

ADA Replaceable TWS Unit (New Construction): TWS unit is easily installed in wet concrete in minutes. TWS unit can be quickly removed and replaced with basic tools.

WARRANTY

ADAREP units shall be guaranteed in writing for a period of five (5) years from date of contract's final completion. The guarantee includes breakage and deformation of the tactile warning surface material.

RADIUS TACTILE - REPLACEMENT TILE

(WET-SET)

24" x 33.25" (609.60 x 844.80mm) Tile
2.35" (59.7 mm) Dome Spacing

CURB RADIUS	'A' DIMENSION	'B' DIMENSION
10'	2'-8 ¹ / ₄ "	2'-2 ¹ / ₄ "
15'	2'-3 ³ / ₄ "	1'-11 ¹ / ₄ "
20'	2'-3 ¹ / ₄ "	1'-11 ³ / ₄ "

MATERIAL LIST			
ITEM	DESCRIPTION	PART NO.	QTY
1			
2			
3			
4			
TRACE DETECTABLE WARNING SURFACE		PART NO. 24RADREP	
MATERIAL REF: 10/04/2016			
PROJECT			
WET SET ADA STD REPLACEABLE TACTILE WARNING SURFACE UNIT 8-BOLT LOCATIONS 2.350" IN LINE TRUNCATED DOME PATTERN PART SIZE 24" x 10', 15', 20" RADIAL PLANS AND DETAILS			
DRAWING NO. ADA-REP24RAD		DATE	
 (800) 372-0519 P.O. Box 3 N.Billerica, Ma. 01862 www.adatile.com			

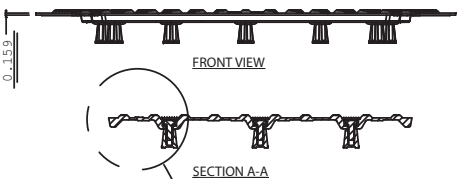
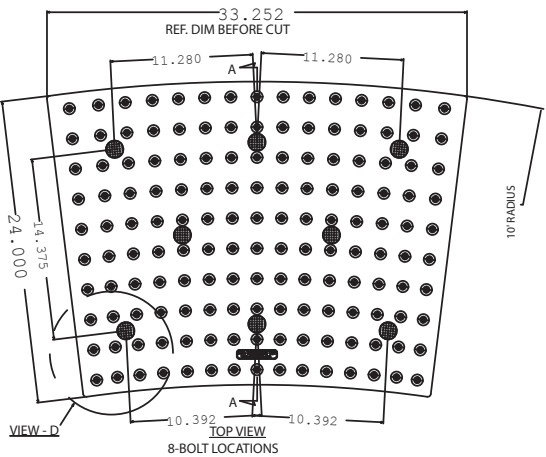
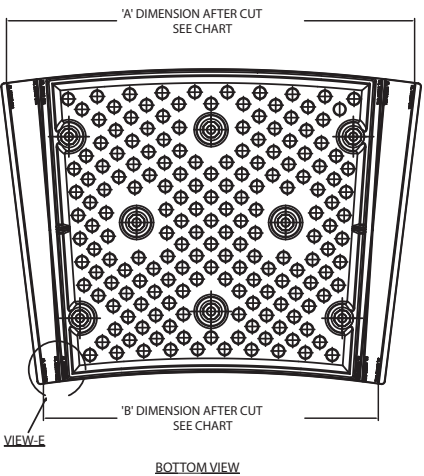

LABELLED RADIUS CUT LINES FOR 10', 15', 20' RADIAL

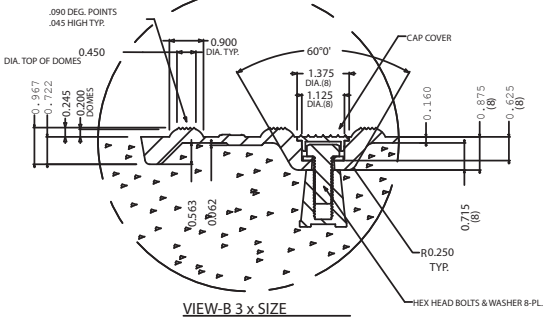
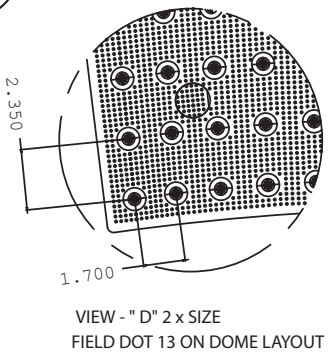
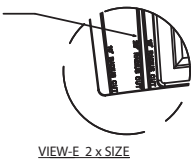



RADIUS TACTILE – SURFACE MOUNT

Installation Procedure

Be sure to read and understand all of these instructions before you begin.

- A.** The installation area should be cleaned of all debris, oil and grease, making sure the area is completely free of moisture. Tactile Panel may be surface mounted on existing pre-cleaned substrate.
- B.** Lay out the Tactile Panel on the substrate as it will appear when installed.
- If required, the Tactile Panel may be cut using a table saw and diamond tipped blade. 10', 15', & 20' radius are pre-scored on backside of tactile panel. See web site for more details.
- C.** Place a 3/8" bead of adhesive on the frame of the bottom of each Tactile Panel. Adhesive yield: 10SF per 10 ounce cartridge. 18-24SF per 20 ounce cartridge.
- D.** Set the Tactile Panel in the installation area. Make all necessary adjustments prior to fastening.
- E.** Fasteners shall be installed in pre-formed fastener locations. Holes shall be drilled using a hammer drill with 1/4" x 2" min SDS bits. The drilled holes must be a minimum of 2" deep. Place fasteners in hole and hammer into place.
- If additional fasteners are required, use a 1/2", six point, 82 degree countersink to add a new fastener location. Follow the same drilling method for installing the fastener.
- F.** Caulk around perimeter of entire installation using BASF NP1 or equivalent.
- All concrete dust present on the Tactile Panel resulting from the drilling process must be cleaned off of the Tactile Panel prior to using any caulking materials.

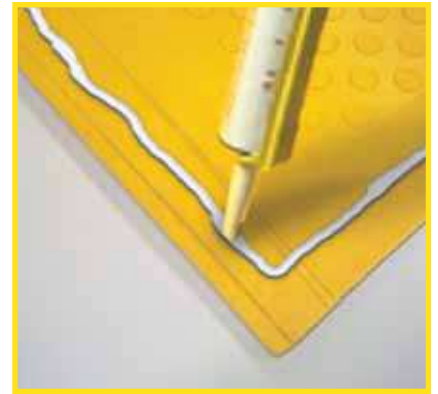

*Not recommended or warranted for asphalt installation.

**View additional photos, drawings and specifications on our website:
www.adatile.com. Call (800) 372-0519 with any questions.**

PRODUCT SIZES
2' x 33 1/4"

APPLICATION
Existing
Concrete Ramps

RADIUS TACTILE – SURFACE MOUNT

Inline Dome Pattern

DOMGEOMETRY

ADAAG, PROWAG and ADA/ABA Compliant in-line truncated dome pattern.

UNIVERSAL RADIUS TWS PANEL

Universal Radius TWS Panel is scored on backside for a 10', 15' and 20' radial condition and may be cut by a table saw to accommodate site conditions.

RADIUS PANEL SIZES

ADA Surface Applied TWS Panel: 24" x 33¼", 16 composite sleeve anchors with stainless steel pins, adhesive & perimeter sealant.

MATERIAL

A durable exterior grade homogenous glass, carbon and fiberglass reinforced composite material which is colorfast and UV stable. The color of the ADAREP unit is uniform throughout and does not rely on any type of paint coating to achieve color stability. Standard colors include: Federal Yellow, Brick Red, Clay Red, Safety Red, Dark Gray and Black. For superior wheelchair, walker and shopping cart mobility, truncated domes have a center-to-center (horizontally and vertically) spacing of 2.35 inches.

PHYSICAL CHARACTERISTICS

Compressive Strength	28,900 psi	ASTM D 695
Flexural Strength	29,300 psi	ASTM D 790
Slip Resistance	1.18 Dry, 1.05 Wet	ASTM C 1028
Chemical Stain Testing	No Deterioration	ASTM D 543
Abrasion Resistance	549	ASTM C 501
Accelerated Weathering	Delta E<5.0 (2,000 hours)	ASTM G 155
Tensile Strength	11,600 psi	ASTM D 638
Load Bearing at 16,000#	No Damage	AASHTO-H20
Freeze/Thaw/Heat	No Disintegration	ASTM C 1026

INSTALLATION

ADA Surface Applied TWS Panel (Existing Concrete): TWS panel can be easily installed (adhered, fastened & sealed) in a matter of minutes.

INCIDENTALS

Fasteners: ¼" x 1½", composite sleeve anchor with stainless steel pins.

Adhesive: One component structural elastomeric adhesive.

Sealant: BASF NP1, Sikaflex 1A, or equivalent.

WARRANTY

Tactile units shall be guaranteed in writing for a period of five (5) years from date of contract's final completion. The guarantee includes breakage and deformation of the tactile warning surface material.

5-Year
Warranty

15' RADIUS CUT
20' RADIUS CUT
10' RADIUS CUT

Pre-Scored

Color
Throughout

RADIUS TACTILE - SURFACE MOUNT

24"x33.25" (609.60 x 844.80mm) Tile
2.35" (59.7 mm) Dome Spacing

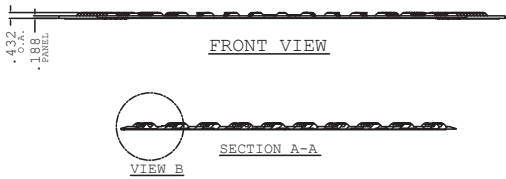
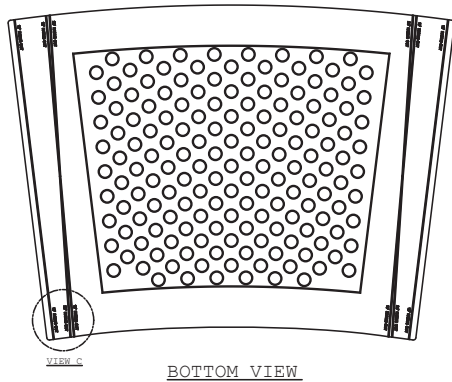
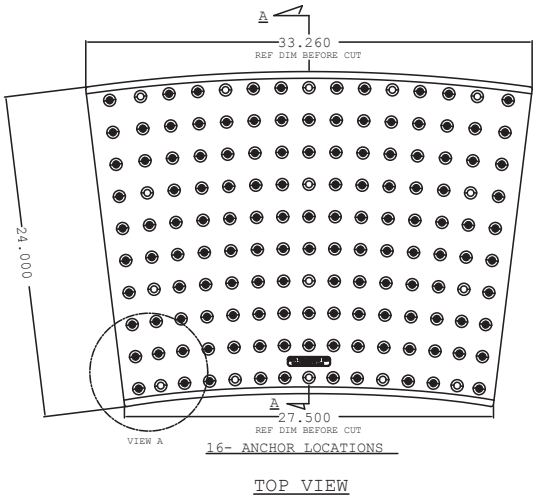

LABELED RADIUS
CUT LINES

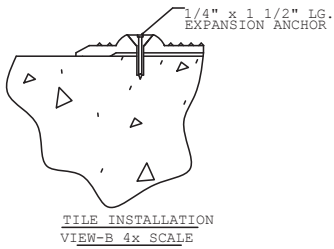
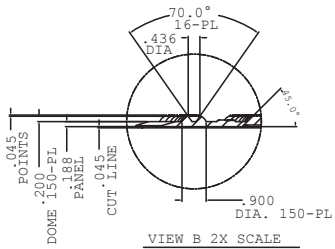
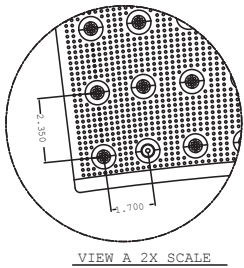
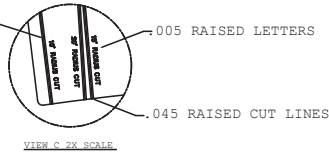

CURB RADIUS	'A' DIMENSION	'B' DIMENSION
10'	2'-8 ¹ / ₄ "	2'-2 ¹ / ₄ "
15'	2'-3 ¹ / ₄ "	1'-11 ¹ / ₄ "
20'	2'-3 ¹ / ₄ "	1'-11 ¹ / ₄ "

MATERIAL LIST			
ITEM	DESCRIPTION	PART NO.	QTY
1			
2			
3			
4			
SCALE		AS NOTED FULL SIZE	
TRADE		PART NO.	
DETECTABLE WARNING SURFACE		SEE MATERIAL LIST	
MATERIAL			
PROJECT			
ADA SURFACE PANEL APPLIED DETECTABLE TWS 24" X 10', 15', 20' RADIAL SOUND ATTENUATING CURB RAMP TILE 2.350" (INLINE DOME) PLANS AND DETAILS			
DRAWING NO.		REV. NO.	
 (800) 372-0519 P.O. Box 3 N.Billerica, Ma. 01862 www.adatile.com			



Wherever you go...
There we are™

- INDUSTRY LEADING SERVICE, DELIVERY AND PRICE
- ONE PIECE APPLICATION
- TIME-SAVING INSTALLATION
- CAST-IN-PLACE REPLACEABLE
- RADIUS REPLACEABLE (WET-SET)
- RADIUS SURFACE MOUNT
- SURFACE MOUNT (RETROFIT)
- CAST-IN-PLACE (WET-SET)
- ADAAG COMPLIANT
- AVAILABLE STANDARD SIZES
2'x3' • 2'x4' • 2'x5' • 3'x4' • 3'x5' • 2'x33¼"
- UNIFORM COLOR THROUGHOUT

PRODUCT INFORMATION / SUBMITTAL