

SURFACE APPLIED PANEL - TOP VIEW

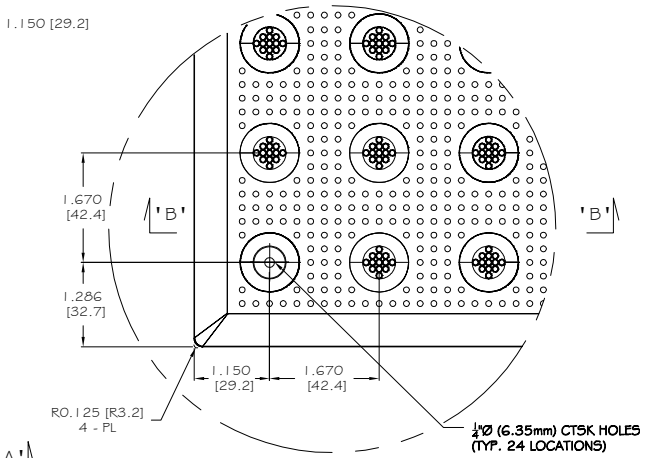

DETAIL A

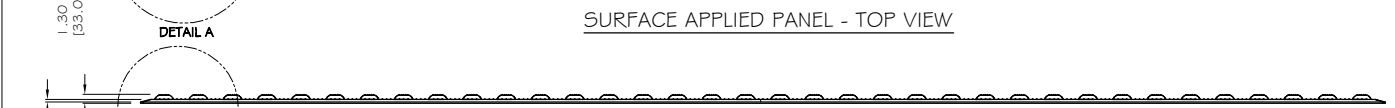
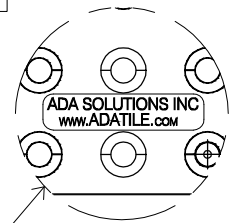

SECTION A-A

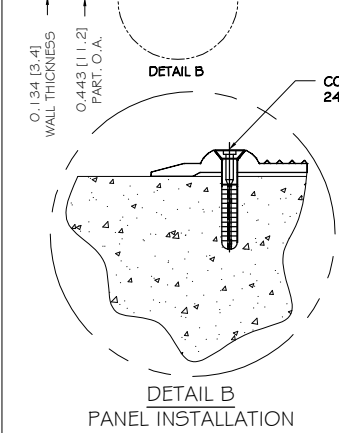

DETAIL B
PANEL INSTALLATION

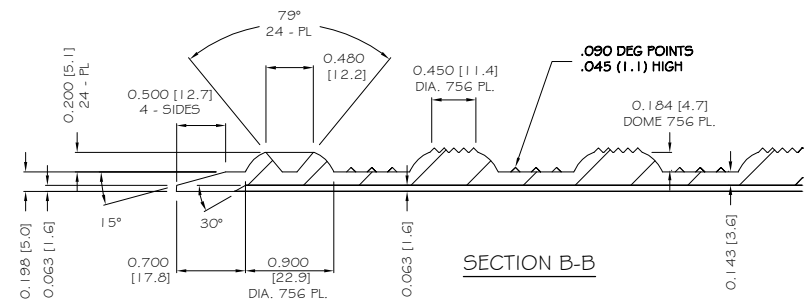
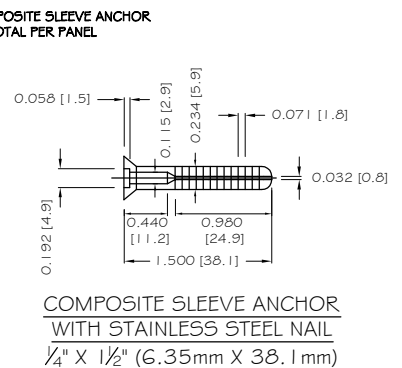

SECTION B-B

ALL DIMENSIONS NOMINAL PRIMARY DIMENSION INCHES mm IN PARENTHESES	
TRADE TACTILE WARNING SURFACE	PART NO. 3660IDRET1_
MATERIAL SMC COMPOSITE	
PROJECT SURFACE APPLIED TACTILE WARNING SURFACE PANEL 24-ANCHOR LOCATIONS 1.670" (42.4MM) IN LINE TRUNCATED DOME PART SIZE: 36" x 60" (914MM X 1524MM) PLANS AND DETAILS	
DRAWING NO. ADA-SA3660_1	DATE 06-16-17
 ADA SOLUTIONS, INC. DETECTABLE WARNING SURFACES FOR PEDESTRIAN CROSSINGS WWW.ADATILE.COM PHONE: (800)372-0519 EMAIL: INFO@ADATILE.COM	