

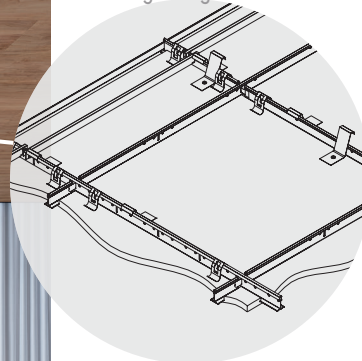

CAD/Revit® drawings at:
armstrongceilings.com/cadrevit



WoodWorks Vector 24" × 48" panels in Constants™ Walnut on heavy-duty Prelude® XL® 15/16" suspension system

Fully accessible wood panels are available in multiple options for acoustical and aesthetic needs.

KEY SELECTION ATTRIBUTES

- Vector® edge detail provides safe and secure downward accessibility without tools and narrow reveal visual (1/4")
- Standard veneers feature various species and cuts for beautiful wood visuals
- ASTM E84 Class A Fire Performance
- The natural warmth of wood can contribute to biophilic designs and building certification standards like the WELL™ v2 "Nature and Place" feature
- Select products included in the FAST134 program – ready to ship in 4 weeks or less
- Create upturns for continuous visuals and clouds with WoodWorks® trim
- Acoustical fleece backing for improved sound absorption
- Installation with minimum plenum clearance
- Shorter lead times and lower cost than custom millwork
- CleanAssure™ family of products – includes disinfectable panels, suspension systems, and trim
- USDA Biobased Content: 100%
- FSC® certified wood available as a premium quoted option

VENEER CUTS

Different cuts of a log will yield different graining visuals. Choose your veneer to achieve your desired look.

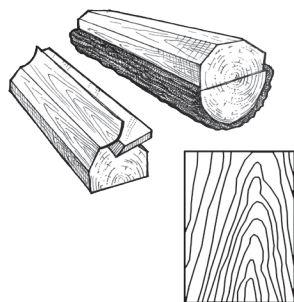

Plain Sliced
Produces the well known cathedral or loop-grain effect.

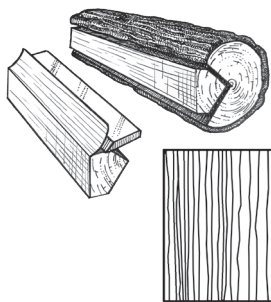

Quarter Sliced
Produces a striped, often straight-grain effect.

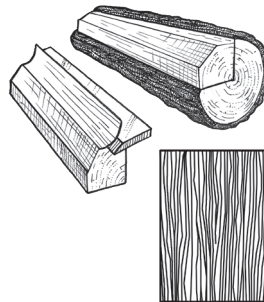

Rift Sliced
Produces a tight, linear grain along the entire length of the veneer.

energy management	recyclable/extended producer resp.	biobased materials	FSC® (for wood)	recycled content	sourcing of materials	material ingredient reporting	low emitting materials	lighting quality	acoustics			
construction waste mgmt	regional materials	design for flexibility	EPD	recyclable/extended producer resp.	biobased materials	FSC® (for wood)	recycled content	sourcing of materials	material ingredient reporting	low emitting materials	lighting quality	acoustics
LOCATION DEPENDENT				PREMIUM OPTION				WITH INFILL PANEL				

FINISH RANGES

The carefully curated species and veneer cuts offer a beautiful natural variation. The images here reflect the visual range that is likely within our product. Darkest to lightest tones may occur within an installation due to the character of wood.



Plain Slice White Maple (NWM)



Plain Slice White Ash (NWA)



Vertical Grain Fir (NWF)



Rift White Oak (NRO)



Plain Slice White Oak (NOK)



Plain Slice Cherry (NPC)



Quartered Mahogany (NGM)



Quartered Sapele (NGS)



Quartered Walnut (NGW)



Plain Slice Walnut (NWN)

CUSTOM FINISHES

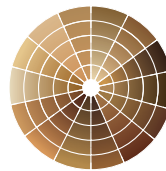

Custom Wood Species and Finishes Available

LEGACY VENEERS

Natural Variations™
Plain Slice



Maple (NMP)

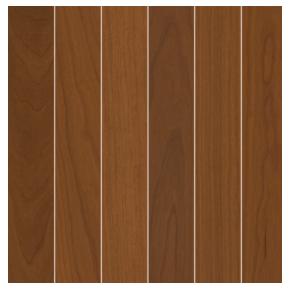

Light Cherry (NLC)

Constants™
Vertical Grain



Walnut (CWA)



Redux Wood Wheat (CRW)

Due to printing limitations, shade may vary from actual product.



WOODWORKS®

Vector®

USDA
CERTIFIED
BIOBASED
PRODUCT
PRODUCT 100%

LEED® WELL™ LBC

80% RECYCLED CONTENT

For LEED contribution contact TechLine

energy management	construction waste mgmt	regional materials	designer flexibility	EPO	recyclables/extended producer resp.	biobased materials	FSC® (for wood)	recycled content	sourcing of raw materials	material ingredient reporting	low emitting materials	lighting quality	acoustics
LOCATION DEPENDENT							PREMIUM OPTION						WITH INFILL PANEL

VISUAL SELECTION

Edge Profile	Item No. ♦	Dimensions Nominal W x L x H (Inches)	Perforations
WOODWORKS® Vector® 15/16" Vector 1/4" Reveal	5401F01_ _ _ _ _	24 x 24 x 3/4"	W1, W2, W3, W4, W5, W6
	6480F01_ _ _ _ _	12 x 48 x 3/4"	W1, W2, W3, W4, W5, W6
	6482F01_ _ _ _ _	24 x 48 x 3/4"	W1, W2, W3, W4, W5, W6

FAST
4 WEEKS
or Less

FAST134 program items ready to ship from manufacturer in 4 weeks or less.
Up-to-date lead times and product options (sizes and colors) at armstrongceilings.com/fast134

Edge Profile	Item No. ♦	Dimensions Nominal W x L x H (Inches)	Perforations
FSC® certified WOODWORKS Vector 15/16" Vector 1/4" Reveal	5401F02_ _ _ _ _	24 x 24 x 3/4"	W1, W2, W3, W4, W5, W6
	6480F02_ _ _ _ _	12 x 48 x 3/4"	W1, W2, W3, W4, W5, W6
	6482F02_ _ _ _ _	24 x 48 x 3/4"	W1, W2, W3, W4, W5, W6

♦ When specifying or ordering, include the appropriate 2-digit perforation and 3-letter veneer suffixes.
For veneers, sizes, and perforation patterns available as special order, call TechLine at 1 877 276-7876.

PERFORMANCE

Fire Rating	CleanAssure™ Disinfectable Panels		
	Fog	Spray	Wipe
Class A	*	*	*
Class A	*	*	*
Class A	*	*	*

ACOUSTICAL INFORMATION

Dots represent high level of performance.

Perforation	Infill Panel Item No.	Description	NRC
W1	Unperforated		N/A
W2	Round Straight	8200T10 Fiberglass School Zone® Fine Fissured™ 1713BL Calla® 2820BK BioAcoustic™ 5823 BioAcoustic 5479 BioAcoustic 1318 Backstage Noir®	0.45 0.55 0.55 0.40 0.40 0.55
W3	Round Diagonal	8200T10 Fiberglass School Zone® Fine Fissured™ 1713BL Calla® 2820BK BioAcoustic™ 5823 BioAcoustic 5479 BioAcoustic 1318 Backstage Noir®	0.45 0.55 0.55 0.40 0.40 0.55
W4	Round Straight	8200T10 Fiberglass School Zone® Fine Fissured™ 1713BL Calla® 2820BK BioAcoustic™ 5823 BioAcoustic 5479 BioAcoustic 1318 Backstage Noir®	0.60 0.60 0.65 0.65 0.65 0.60
W5	Oval Straight Slotted	8200T10 Fiberglass School Zone® Fine Fissured™ 1713BL Calla® 2820BK BioAcoustic™ 5823 BioAcoustic 5479 BioAcoustic 1318 Backstage Noir®	0.50 0.50 0.55 0.45 0.45 0.55
W6	Oval Straight Slotted	8200T10 Fiberglass School Zone® Fine Fissured™ 1713BL Calla® 2820BK BioAcoustic™ 5823 BioAcoustic 5479 BioAcoustic 1318 Backstage Noir®	0.40 0.35 0.35 0.45 0.45 0.35

EXAMPLE: **5401 F02 W2 NWM**
 Panel Dimension/Type: 24" x 24"
 Substrate: FSC-certified
 Perforation: W2 Round Straight
 Finish: Plain Slice White Maple Fg 6006

PERFORATION OPTIONS (Actual 1:6 scale shown)

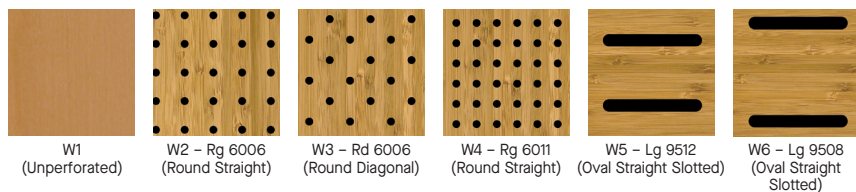

Custom Perforations Available

NOTE: Slotted perforations run parallel to the length of the panel and borders vary with panel size.

energy management	construction waste mgmt.	regional materials	design for flexibility	EPD	recyclable/extended producer resp.	biobased materials	FSC® (for wood)	recycled content	sourcing of low materials	material ingredient reporting	low emitting materials	lighting quality	acoustics
LOCATION DEPENDENT					PREMIUM OPTION					WITH INFILL PANEL			

ACCESSORIES

Item No. ◆	Description	Included with Panels	Required for Install	Pcs/Ctn
6041	 Hold Down Clips	Yes*	Yes	N/A
7870	Spring Border Clip	No	Optional method	1000
7425, 7445	 24" Stabilizer Bar, 48" Stabilizer Bar	No	Yes**	100
MBAC	 Main Beam Adapter Clip	No	Optional method	70/50
6408_---	WoodWorks® 3/4" x 300" Edgbanding Coordinating Faux Wood	No	No	25 LF

Reference Price List for minimum order quantities.

◆ When specifying or ordering, include the appropriate 3-letter color suffix that coordinates with your WoodWorks ceiling (e.g. 6408 N W M).

* If replacement clips are needed, order Item 6041 (quantity 100 PCS/CTN).

** Stabilizer bars are required if grid is not attached to perimeter with GCWA or BERC2.

VECTOR PANEL INSTALLATION DETAILS

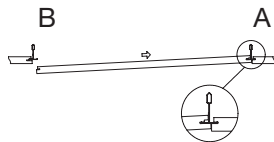

Step 1: Fully insert the deepest kerf of edge "A", the access kerf, onto the exposed grid flange.

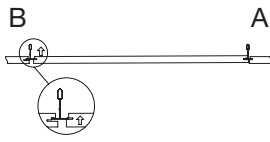

Step 2: Raise the "B" edge of the panel, the registration kerf, into the grid opening until the kerf lines up with the grid flange.

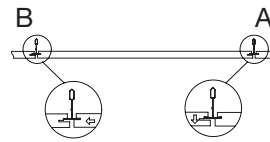

Step 3: Slide the panel so that the registration kerf on edge "B" engages the grid flange. Ensure that the access kerf on edge "A" drops down into the correct position.

PANEL FACE OFFSET

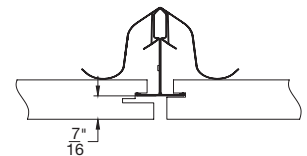

SUSPENSION SYSTEMS (Heavy-duty)

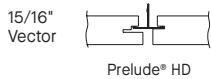

15/16" Vector
Prelude® HD
Heavy-Duty Prelude® XL® HD suspension system is available in many standard colors. Other colors available as special order.

WOODWORKS® TRIM INSTALLATION

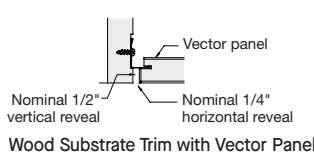

Wood Substrate Trim with Vector Panel

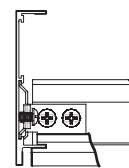

Aluminum Substrate Trim Assembly for Vector Panel

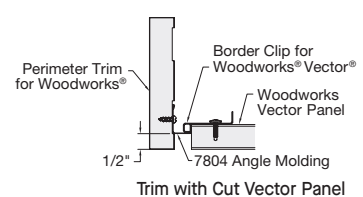

Trim with Cut Vector Panel

PHYSICAL DATA

Material
Fire-rated particle board (FRPB) with real wood veneers. Vertical Grain Fir (NVF) is FRPB with a reconstituted veneer.

Surface Finish
Clear or tinted semi-gloss coating

Fire Performance
Class A: ASTM E84 surface burning characteristics. Flame Spread Index 25 or less. Smoke Developed Index 50 or less.

CAN/ULC S102 surface burning characteristics. Flame Spread Rating 25 or less. Smoke Developed Classification 50 or less.

ASTM E1264 Classification
ASTM E1264 Type XX - Fire Class A

Primary (Embodied) Energy
See all LCA information on our EPDs.

Application Considerations
Variation among panels may occur due to the natural characteristics of the wood and grain.

It is very important that WoodWorks panels are climatized prior to installation. Relative humidity between 25% and 55%, and temperatures between 50°F and 86°F, must be maintained throughout the life of the product.

Design Considerations
All perforated panels are standard with fleece attached. Panels without fleece must be specified.
Different panel sizes should not be installed together. Perforated border on 24" x 72" panels are different than other panel sizes.
Vector safety clips included with panels may be visible through panel perforations.

Specification Consideration
Attention: For FSC-certified wood products to maintain their CoC certification, products must be sold to a CoC-certified distributor or directly to the installing contractor. Failure to do so breaks the CoC.

Seismic Restraint
WoodWorks Vector panels have been engineered, tested, and approved for application in all seismic areas when installed per Armstrong Ceilings installation instructions.

Cleaning and Disinfecting
Cleaning and CDC-approved disinfecting options available on armstrongceilings.com/cleaning

FAST134 Program Considerations
Size of Job Matters: Big jobs, over 2500 SF or 50 pieces for shapes/vertical elements will have longer lead times.
Location Matters: Transit time not included. We are ready to ship in 1 week on FAST1 items. However, transit to the states west of Wyoming may add time.
Distributor Truck Schedule Matters: We rely on distribution to help move products around the country. When speed matters, work with your local distributor to ensure FAST134 service.

Stock vs. Made-to-Order Matters: FAST3 & FAST4 items are made-to-order and will ship direct to distributor. FAST1 (stocked items) will go through distribution and depend on distributor truck schedules.

Warranty
Details at armstrongceilings.com/warranty

Weight; Square Feet
Panels – 2.75 LBS/SF

