

2024/
2021/2018/2015
IBC and IRC
Code Compliant
ICC-ESR 4934



Expanding Your Solutions



CT Shaft Wall System

CEMCO's Solution for Fire-Rated Shaft Walls,
Stairwells, and Horizontal Ceilings

Table of Contents

Introduction / Code Compliance	3
CT Stud Physical and Section Properties	4
Shaft Wall Components	5
Vertical Limiting Heights (1-Hour Shaft Wall System)	6
Vertical Limiting Heights (2-Hour Shaft Wall System)	7
Vertical Limiting Heights (2-Hour Stairwell System)	8
Shaft Wall Vertical Fire Assemblies	9
Horizontal Spans	10
Shaft Wall Horizontal Fire Assemblies	11
Fire-Rated Shaft Wall Assemblies	12-14
CT Fire-Rated Shaft Wall Systems & Sound Tested Assemblies	15
Typical Details	16-17
Shaft Wall Installation Instructions	18

California's Proposition 65 Warning

California's Safe Drinking Water and Toxic Enforcement Act of 1986 – commonly referred to as Proposition 65 ("Prop 65") (27 Cal. Code Reg. S 25600, et seq.) – has recently changed, requiring manufacturers to provide a warning based on its knowledge about the presence of one or more of the almost 900 listed chemicals which are known to the State of California to cause cancer and birth defects, or other reproductive harm. With a few exceptions, manufacturers operating in the state of California as well as those entities who distribute, import, package, and/or supply products into the State of California are now required provide a "clear and reasonable" warning to consumers that their products may contain one or more of these listed chemicals or compounds. The complete list is available at www.P65Warnings.ca.gov.

In compliance with the new requirements, we are notifying each of our customers that CEMCO products contain Nickel (metallic) and/or other chemicals listed which are known to the State of California to cause cancer and birth defects or other reproductive harm. Safety data sheets from our major suppliers are available from CEMCO on our website at www.cemcosteel.com.

Introduction

CT Shaft Wall System

CEMCO's new CT Shaft Wall Product is manufactured from hot-dipped galvanized steel in web depths of 2-1/2", 4" and 6" in 20 ga. (33 mil), and in 18 ga. (43 mil) thicknesses with corresponding Tabbed J-Runners. The CT Shaft Wall System is approved with multiple gypsum board and liner manufacturers in many 1 and 2-hour UL Listed fire-rated shaft wall assemblies.

AISI, ASTM, & Code Standards

- ICC-ESR 4934
- ASTM A653/653M – Specification for Steel Sheet, Zinc-Coated (Galvanized) or Zinc-Iron Alloy-Coated (Galvannealed) by the Hot-Dip Process.
- ASTM A924/924M – Specification for General Requirements for Sheet Steel, Metallic-Coated by the Hot-Dip Process.
- ASTM A1003/1003M – Specification for Steel Sheet, Carbon, Metallic and Nonmetallic-Coated for Cold-Formed Framing Members.
- ASTM C645 – Standard Specification for Nonstructural Steel Framing Members.
- IBC: 2015, 2018, 2021, 2024
- CBC: 2016, 2019, 2022
- AISI: S100, S220
- UL-2079 5th edition

Scope of evaluation – UL ER25033-01:

- 2018 and 2015 International Building Code (IBC)
- 2019 California Building Code (CBC)
- 2019 California Residential Code (CRC)
- 2020 City of Los Angeles Building Code (LABC)
- 2019 Chicago Building Code
- 2020 Florida Building Code – Residential

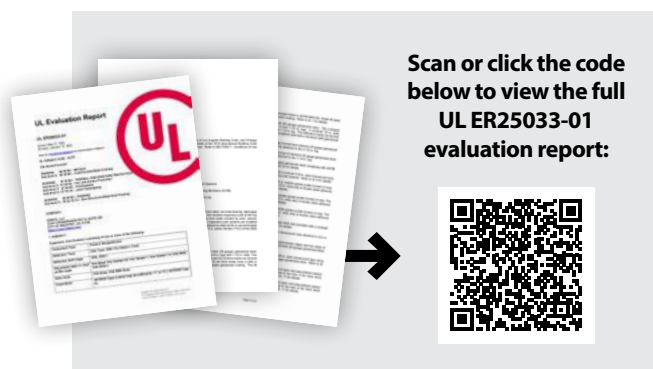

https://cemcosteel.com/app/uploads/2022/01/R25033-Vol1_CEMCO_Firestopping-Products-unlocked-1.pdf



Technical Support and Resources

- Contact CEMCO's Technical Services Department at 800-775-2362 or email at technicalservices@cemcosteel.com.
- Visit www.cemcosteel.com for all catalogs, specification sheets, typical details, and acoustical/UL reports.

LEED v4 for Building & Design Construction

- MR Prerequisite: Construction and Demolition Waste Management Planning.
- MR Credit: Construction and Demolition Waste Management.
- MR Credit: Building Product Disclosure and Optimization – Sourcing of Raw Materials, Option 2.
- MR Credit: Building Product Disclosure and Optimization – Material Ingredients, Option 1.
- MR Credit: Building Life-Cycle Impact Reduction, Option 4.

MR Credit 4.1/4.2 – Recycled Content

- Total Recycled Content: 36.9%
- Post-Consumer: 19.8%
- Pre-Consumer: 14.4%

Physical Properties							Section Properties			
"CT" Stud Designation	Web	Gauge	Mil	Yield Strength (ksi)	Design Thickness (in)	Coating	Weight (lb/ft)	Area (in ²)	I _x (in ⁴)	S _x (in ³)
20CT212	2-1/2	20	33	40	0.0346	G40	0.840	0.247	0.240	0.167
20CT4	4	20	33	40	0.0346	G40	1.016	0.299	0.708	0.307
20CT6	6	20	33	40	0.0346	G40	1.252	0.368	1.858	0.545
18CT212	2-1/2	18	43	40	0.0451	G60	1.090	0.320	0.307	0.214
18CT4	4	18	43	40	0.0451	G60	1.319	0.388	0.909	0.395
18CT6	6	18	43	40	0.0451	G60	1.625	0.478	2.393	0.703

Notes:

1. Uncoated steel thickness. Thickness is for carbon sheet steel.
2. I_x = Moment of Inertia
3. S_x = Section Modulus

Member	Model Number	Weight (lb/ft)	Area (in ²)	I _x (in ⁴)	S _x (cu in)	Yield Strength (ksi)
2-1/2" J-Runner	212JR-23	0.448	0.1346	0.117	0.085	3.00
	212JR-34	0.670	0.2039	0.192	0.130	4.96
4" J-Runner	400JR-23	0.573	0.1705	0.351	0.163	3.00
	400JR-34	0.857	0.2577	0.574	0.251	4.96
6" J-Runner	600JR-23	0.740	0.2183	0.937	0.295	3.00
	600JR-34	1.107	0.3295	1.523	0.457	4.96
2-1/2" Jamb Strut	212JS-34	0.818	0.2398	0.226	0.143	3.00
4" Jamb Strut	400JS-34	1.006	0.2936	0.647	0.270	3.00
6" Jamb Strut	600JS-34	1.256	0.3654	1.673	0.485	3.00

Notes:

1. Studs and runners comply with ASTM C645
2. Properties of steel framing members have been calculated in conformance with AISI specifications.
3. S_x: Full section modulus to be used with corresponding design stress.

CEMCO CT STUD

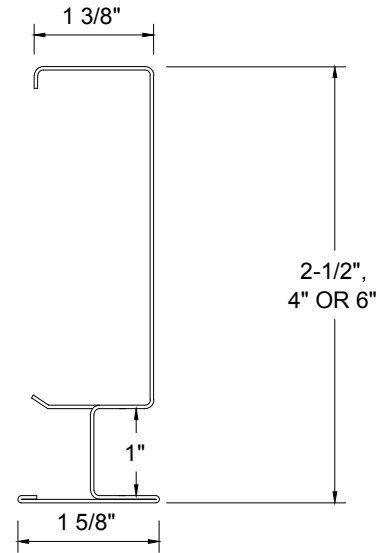
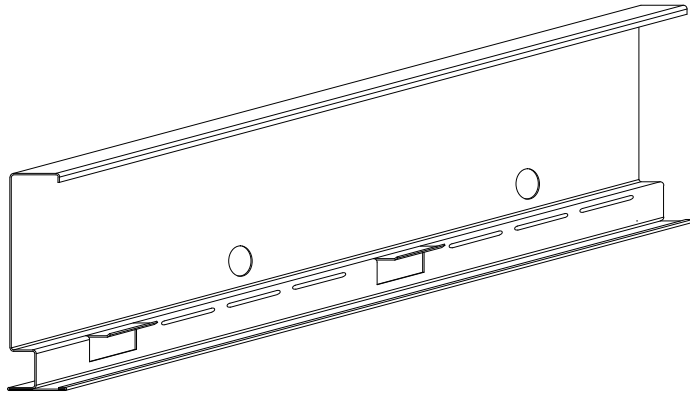

JL CORNER

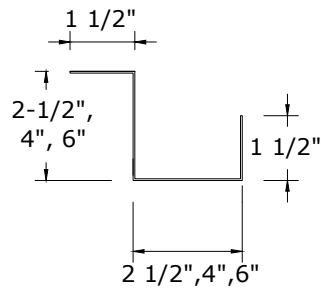
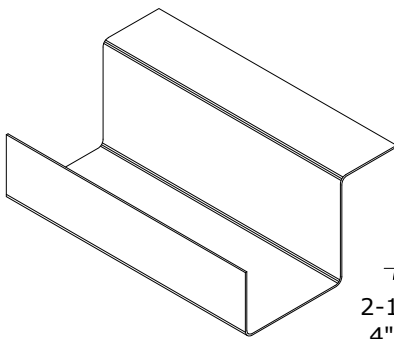

J-DLT (DEEP LEG J-RUNNER)

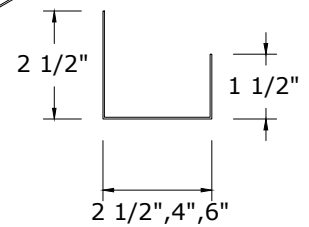
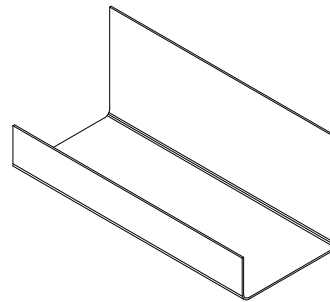

TABBED J-RUNNER

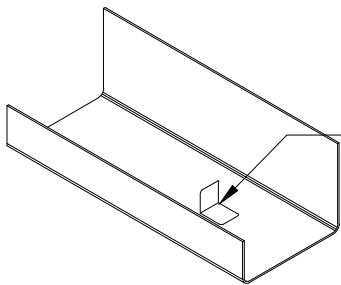

TABS BENT OUT AS NEEDED AT 12" O.C.

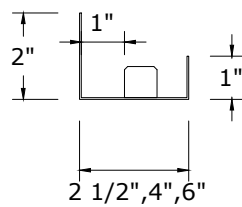

J STRUT (JAMB STRUT)

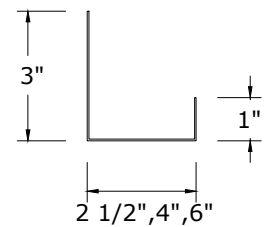
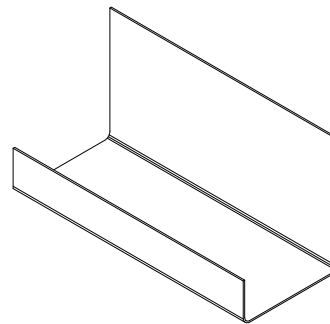

Vertical Limiting Heights									
Stud Depth	Model Number	Gauge	Design Thickness (in)	Yield (ksi)	Deflection	5 psf	7.5 psf	10 psf	15 psf
1-Hour Shaft Wall System									
2-1/2"	20CT212	20	0.0346	40	L/120	16' 0"	13' 11"	12' 8"	6' 10"
					L/180	14' 1"	12' 4"	11' 2"	6' 10"
					L/240	12' 10"	11' 2"	10' 2"	6' 10"
					L/360	11' 2"	9' 8"	8' 7"	0' 0"
	18CT212	18	0.0451	40	L/120	16' 2"	14' 2"	12' 11"	6' 7"
					L/180	13' 11"	12' 2"	11' 1"	6' 7"
					L/240	12' 5"	10' 10"	9' 10"	6' 7"
					L/360	10' 5"	9' 1"	8' 4"	0' 0"
4"	20CT4	20	0.0346	40	L/120	20' 10"	18' 2"	16' 6"	7' 2"
					L/180	18' 5"	16' 1"	14' 7"	7' 2"
					L/240	16' 10"	14' 8"	13' 4"	7' 2"
					L/360	14' 8"	12' 10"	11' 8"	7' 2"
	18CT4	18	0.0451	40	L/120	23' 7"	20' 7"	17' 7"	6' 7"
					L/180	20' 10"	18' 1"	16' 6"	6' 7"
					L/240	18' 11"	16' 6"	15' 0"	6' 7"
					L/360	16' 7"	14' 6"	13' 0"	6' 7"
6"	20CT6	20	0.0346	40	L/120	27' 4"	22' 4"	18' 4"	6' 11"
					L/180	24' 6"	21' 5"	18' 4"	6' 11"
					L/240	22' 4"	19' 6"	17' 8"	6' 11"
					L/360	19' 5"	17' 0"	15' 5"	6' 11"
	18CT6	18	0.0451	40	L/120	30' 1"	23' 6"	17' 7"	6' 7"
					L/180	26' 2"	22' 11"	17' 7"	6' 7"
					L/240	23' 7"	20' 7"	17' 7"	6' 7"
					L/360	20' 6"	17' 11"	16' 4"	6' 7"

Notes:

1. Allowable heights are based on the transverse load test complying with ICC-ES AC86 and AISI S916-15.
2. Studs spaced at 24" O.C. maximum.
3. Standard Tabbed J-Runner is used as both top and bottom track.
4. CT-Shaft Stud limiting heights were tested with 5/8" Type-X gypsum board oriented vertically.



CT Shaft Wall System

Vertical Limiting Heights (2-Hour Shaft Wall System)

Vertical Limiting Heights									
Stud Depth	Model Number	Gauge	Design Thickness (in)	Yield (ksi)	Deflection	5 psf	7.5 psf	10 psf	15 psf
2-Hour Shaft Wall System									
2-1/2"	20CT212	20	0.0346	40	L/120	16' 11"	14' 10"	13' 5"	6' 11"
					L/180	15' 1"	13' 2"	12' 0"	6' 11"
					L/240	13' 11"	12' 2"	11' 1"	6' 11"
					L/360	12' 4"	10' 8"	9' 7"	6' 11"
	18CT212	18	0.0451	40	L/120	17' 0"	14' 11"	13' 6"	6' 7"
					L/180	14' 11"	13' 0"	11' 10"	6' 7"
					L/240	13' 6"	11' 10"	10' 8"	6' 7"
					L/360	11' 6"	10' 10"	9' 1"	0' 0"
4"	20CT4	20	0.0346	40	L/120	21' 8"	19' 0"	17' 2"	6' 11"
					L/180	19' 5"	16' 11"	15' 5"	6' 11"
					L/240	17' 10"	15' 6"	14' 1"	6' 11"
					L/360	15' 8"	13' 8"	12' 5"	6' 11"
	18CT4	18	0.0451	40	L/120	24' 8"	21' 7"	17' 7"	6' 7"
					L/180	21' 10"	19' 1"	17' 4"	6' 7"
					L/240	20' 0"	17' 6"	15' 11"	6' 7"
					L/360	17' 8"	15' 6"	14' 0"	6' 7"
6"	20CT6	20	0.0346	40	L/120	27' 7"	24' 2"	18' 4"	6' 11"
					L/180	25' 4"	22' 1"	18' 4"	6' 11"
					L/240	23' 1"	20' 2"	18' 4"	6' 11"
					L/360	20' 2"	17' 7"	16' 0"	6' 11"
	18CT6	18	0.0451	40	L/120	31' 2"	23' 6"	17' 7"	6' 7"
					L/180	27' 5"	23' 6"	17' 7"	6' 7"
					L/240	24' 11"	21' 10"	17' 7"	6' 7"
					L/360	21' 11"	19' 1"	17' 5"	6' 7"

- Notes:**
1. Allowable heights are based on the transverse load test complying with ICC-ES AC86 and AISI standards.
 2. Studs spaced at 24" O.C. maximum.
 3. Standard Tabbed J-Runner is used as both top and bottom track.
 4. CT-Shaft Stud limiting heights were tested with 5/8" Type-X gypsum board oriented vertically.

Vertical Limiting Heights									
Stud Depth	Model Number	Gauge	Design Thickness (in)	Yield (ksi)	Deflection	5 psf	7.5 psf	10 psf	15 psf
2-Hour Stairwell System									
4"	20CT4	20	0.0346	40	L/120	21' 10"	18' 8"	16' 2"	9' 11"
					L/180	19' 4"	16' 11"	15' 4"	9' 11"
					L/240	17' 8"	15' 6"	14' 1"	9' 11"
					L/360	15' 8"	13' 8"	12' 6"	9' 11"
	18CT4	18	0.0451	40	L/120	24' 2"	21' 1"	19' 2"	10' 5"
					L/180	21' 6"	18' 8"	17' 0"	10' 5"
					L/240	19' 8"	17' 2"	15' 7"	10' 5"
					L/360	17' 4"	15' 2"	13' 8"	10' 5"
6"	20CT6	20	0.0346	40	L/120	28' 11"	23' 7"	18' 4"	10' 10"
					L/180	25' 10"	22' 6"	18' 4"	10' 10"
					L/240	23' 8"	20' 8"	18' 4"	10' 10"
					L/360	20' 11"	18' 2"	16' 7"	10' 10"
	18CT6	18	0.0451	40	L/120	30' 7"	25' 0"	21' 8"	10' 5"
					L/180	27' 5"	23' 11"	21' 8"	10' 5"
					L/240	25' 2"	22' 0"	20' 0"	10' 5"
					L/360	22' 2"	19' 5"	17' 7"	10' 5"

Notes:

1. Allowable heights are based on the transverse load test complying with ICC-ES AC86 and AISI standards.
2. Studs spaced at 24" O.C. maximum.
3. Standard Tabbed J-Runner is used as both top and bottom track.
4. CT-Shaft Stud limiting heights were tested with 5/8" Type-X gypsum board oriented vertically.

1 HOUR SHAFT WALL ASSEMBLY

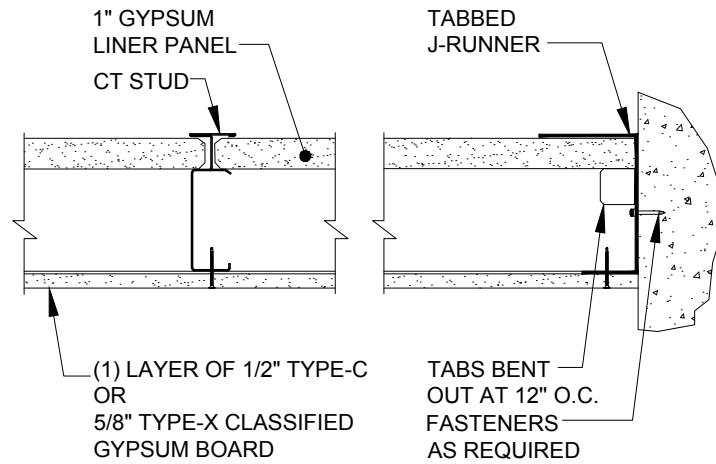

2 HOUR SHAFT WALL ASSEMBLY

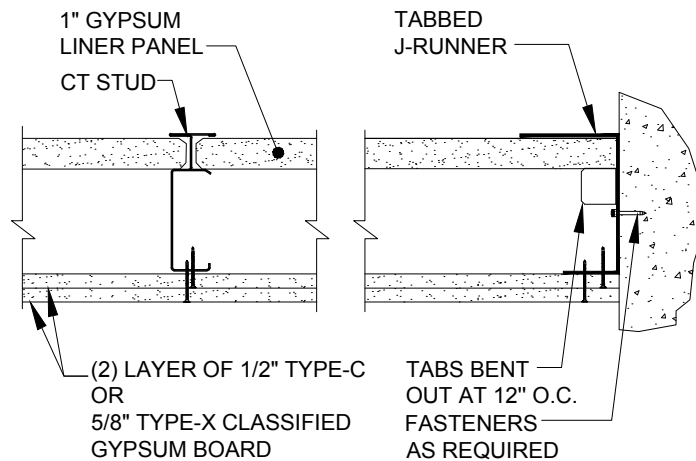

2 HOUR STAIRWELL ASSEMBLY

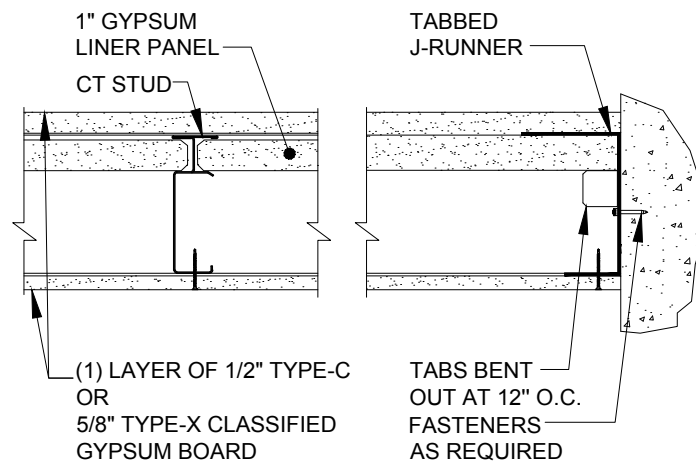

Web Depth	Gauge	Design Thickness (in)	Mil	1 Layer Type "X" 1" Shaft Liner			2 Layer Type "X" 1" Shaft Liner			2 Layers of Type "C" 1" Shaft Liner		
				L/120	L/240	L/360	L/120	L/240	L/360	L/120	L/240	L/360
2-1/2"	20	0.0346	33	13'-3"	10'-6"	9'-2"	12'-0"	9'-6"	8'-4"	12'-2"	9'-8"	8'-5"
4"	20	0.0346	33	18'-11"	15'-0"	13'-1"	17'-2"	13'-8"	11'-11"	17'-6"	13'-10"	12'-1"
6"	20	0.0346	33	25'-11"	20'-7"	18'-0"	23'-8"	18'-9"	16'-4"	24'-0"	19'-0"	16'-7"
4"	18	0.0451	43	20'-5"	16'-2"	14'-2"	18'-7"	14'-9"	12'-11"	18'-10"	15'-0"	13'-1"
6"	18	0.0451	43	28'-0"	22'-2"	19'-5"	25'-6"	20'-3"	17'-8"	25'-11"	20'-7"	18'-0"

Notes:

1. Not designed to carry live loads, mechanical loads or for material storage area use.
2. Dead Loads include: 5/8" Type X 2.2 PSF
1/2" Type C: 2.0 PSF
1" Shaft Liner: 4.0 PSF
CT-Stud Weight

1 HOUR HORIZONTAL ASSEMBLY

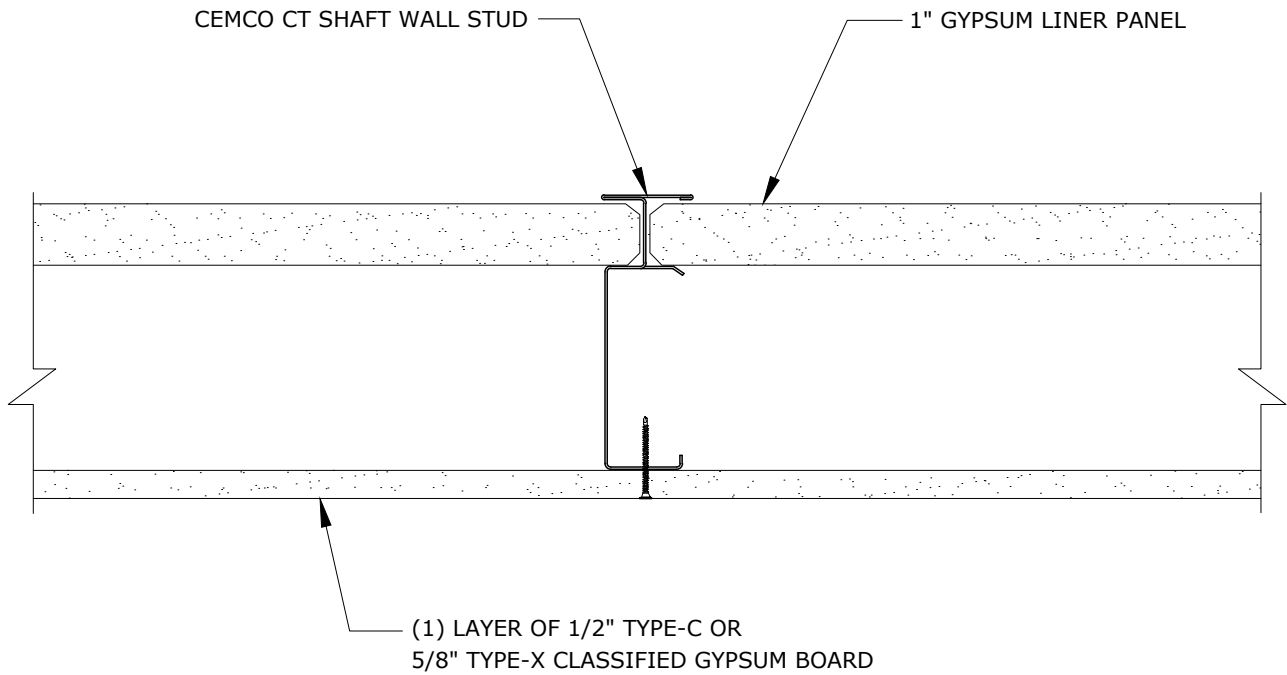

2 HOUR HORIZONTAL ASSEMBLY

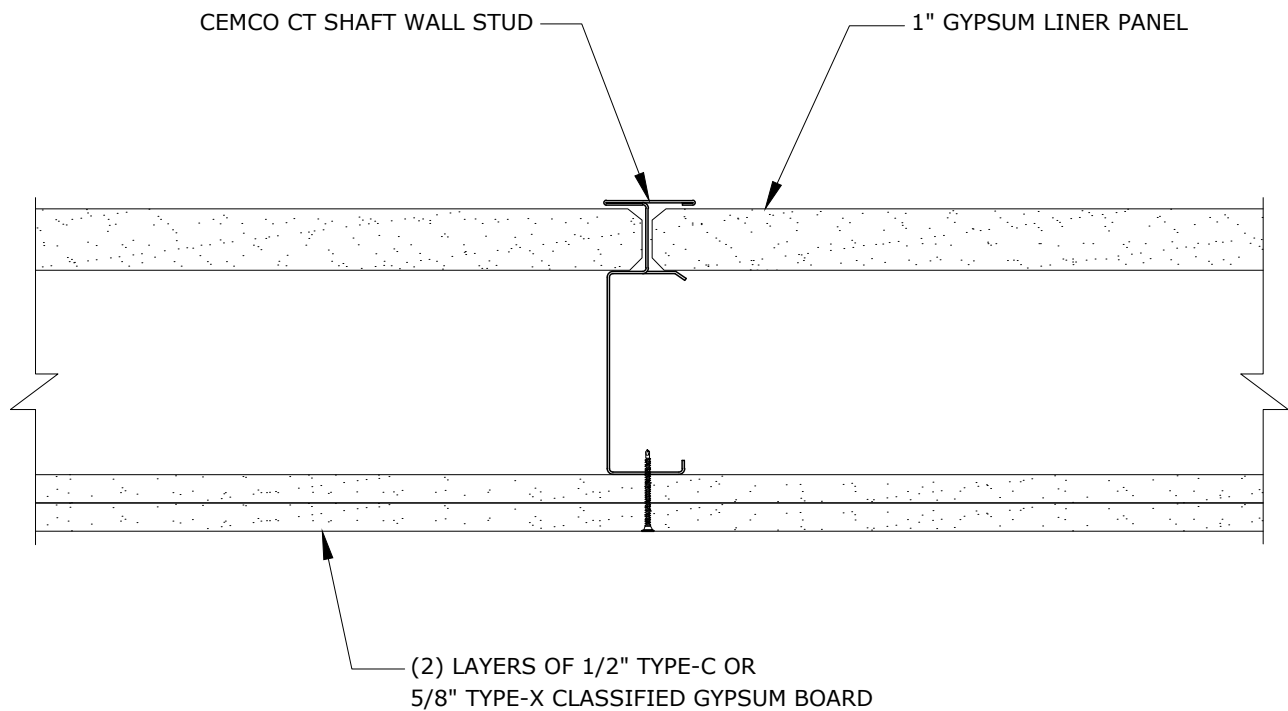

HW-D-0525 SHAFT WALL FLUTED DECK

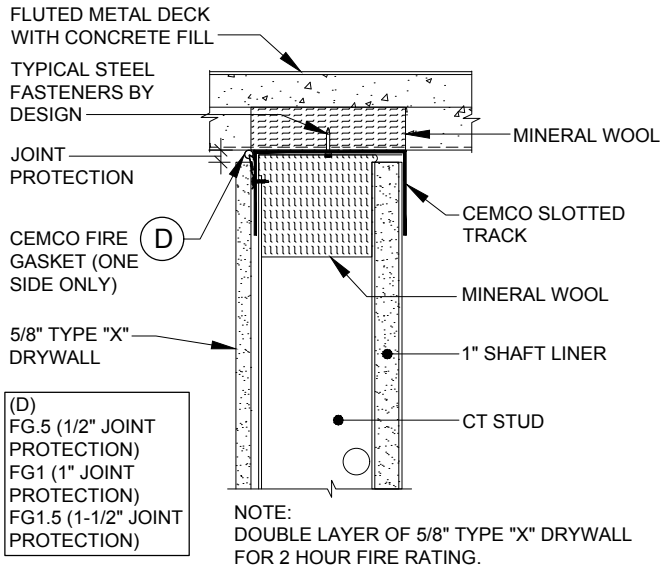

HW-D-0625 1HR SHAFT WALL, CONCRETE SLAB

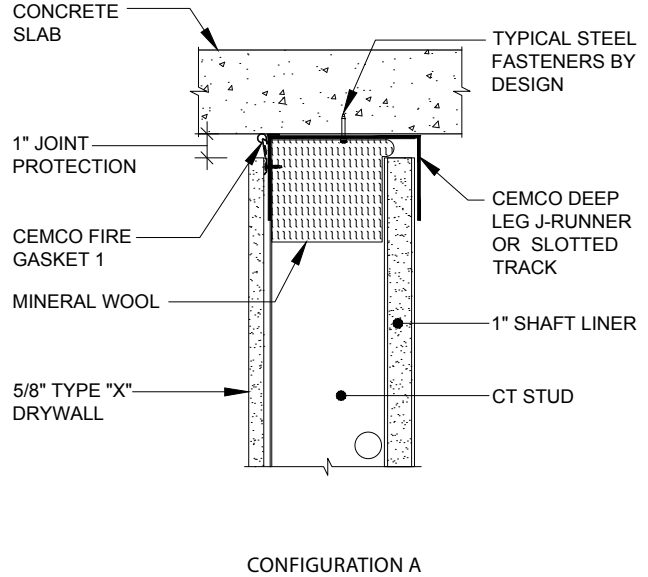

HW-D-0584 SHAFT WALL FLUTED DECK

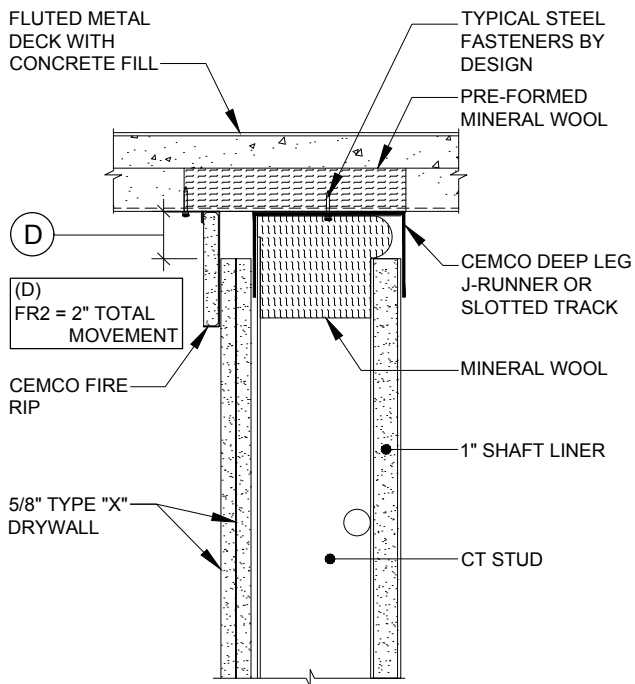

HW-D-0653 SHAFT WALL CANTILEVER UNDER BEAM

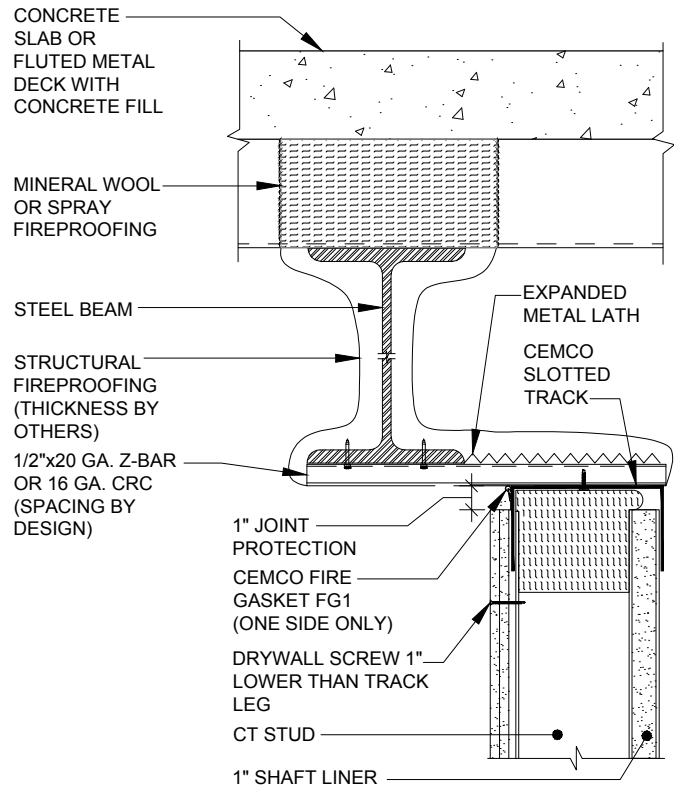

GENERAL NOTES:

1. INSTALL 3" WIDE, 4 PSF MINERAL WOOL COMPRESSED 33% FROM THE FACE OF THE SHAFT LINER TO THE INSIDE LEG OF THE TRACK ON ALL SHAFT WALL HEAD-OF-WALL JOINT SYSTEMS.
2. NO ADDITIONAL SEALANT OR SPRAY IS REQUIRED OVER MINERAL WOOL IN THE SHAFTWALL CAVITY.
3. ALL HEAD-OF-WALL TRACKS SHOULD HAVE A MINIMUM 1-1/2" FRONT LEG FOR DEFLECTION REQUIREMENTS.
4. ALL DEFLECTION CAPABILITIES ARE SPECIFIC TO THE CEMCO PRE-FORMED FIRESTOP CHECK REFERENCE GUIDE FOR MOVEMENT CAPABILITIES.

HW-D-0587 1HR SHAFT WALL, PARALLEL & DIRECTLY UNDER DECK FLUTE

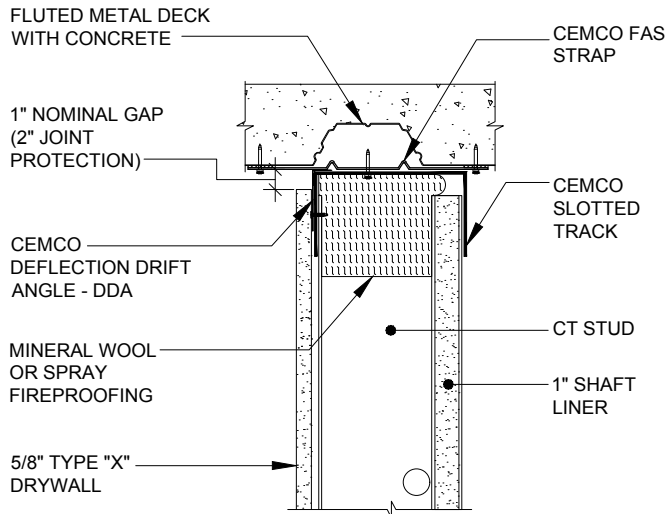

NOTES:

1. TESTED PER UL-2079 4TH EDITION.
2. IF CODE REQUIRES UL-2079 5TH EDITION, ADDITIONAL FILL MATERIAL MAY BE REQUIRED IN THE JOINT.

WW-S-0094 SHAFT WALL VERTICAL JOINT

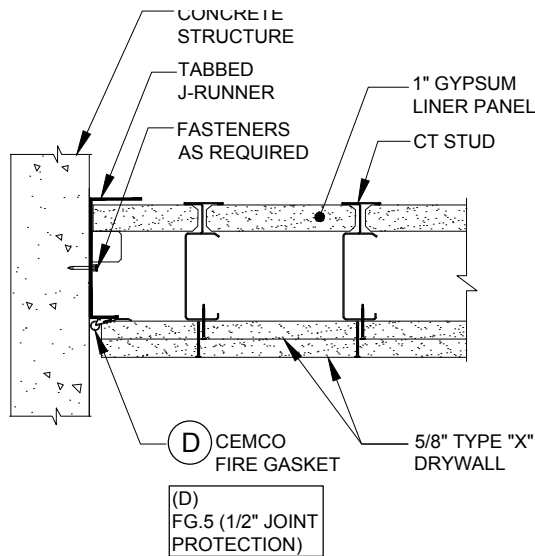

GENERAL NOTES:

1. INSTALL 3" WIDE, 4 PSF MINERAL WOOL COMPRESSED 33% FROM THE FACE OF THE SHAFT LINER TO THE INSIDE LEG OF THE TRACK ON ALL SHAFT WALL HEAD-OF-WALL JOINT SYSTEMS.
2. NO ADDITIONAL SEALANT OR SPRAY IS REQUIRED OVER MINERAL WOOL IN THE SHAFTWALL CAVITY.

HW-D-0621 (A) SHAFT WALL SLAB BY-PASS

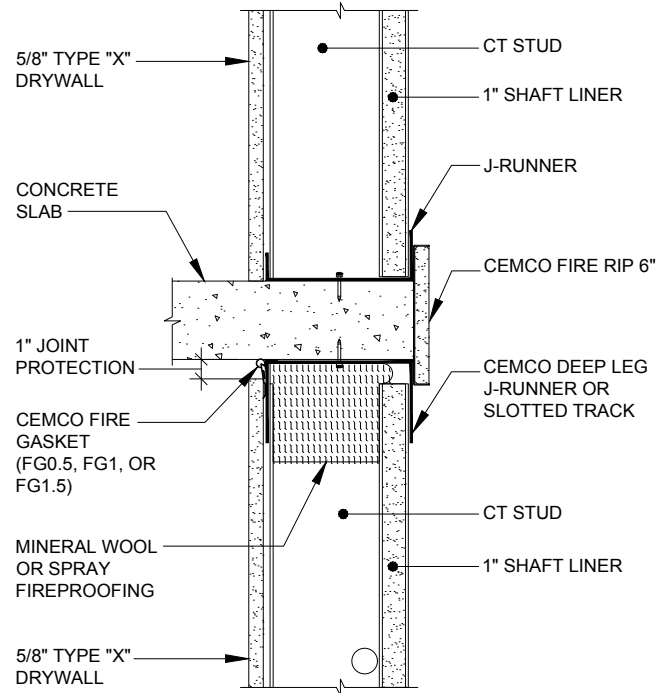

HW-D-0621 (B) SHAFT WALL SLAB BY-PASS

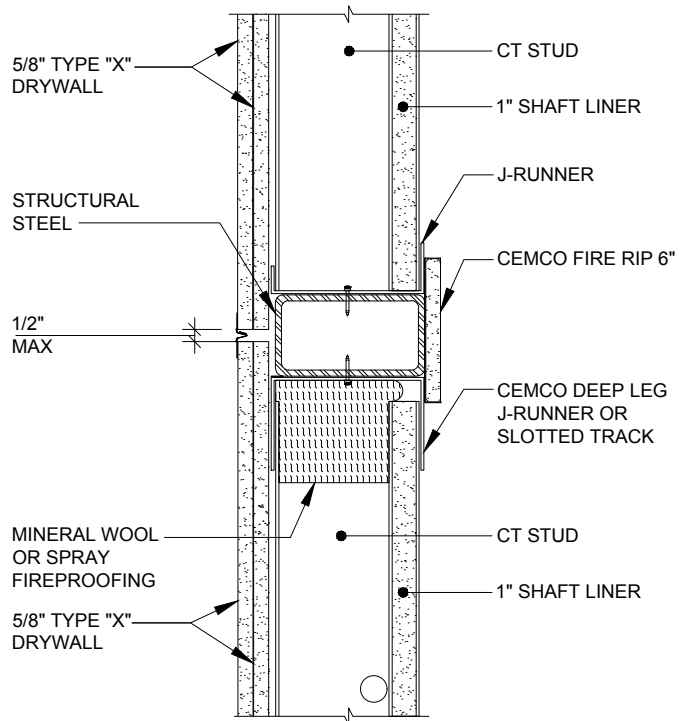

3. ALL HEAD-OF-WALL TRACKS SHOULD HAVE A MINIMUM 1-1/2" FRONT LEG FOR DEFLECTION REQUIREMENTS.
4. ALL DEFLECTION CAPABILITIES ARE SPECIFIC TO THE CEMCO PRE-FORMED FIRESTOP CHECK REFERENCE GUIDE FOR MOVEMENT CAPABILITIES.

HW-D-0585 SHAFT WALL AT CONCRETE

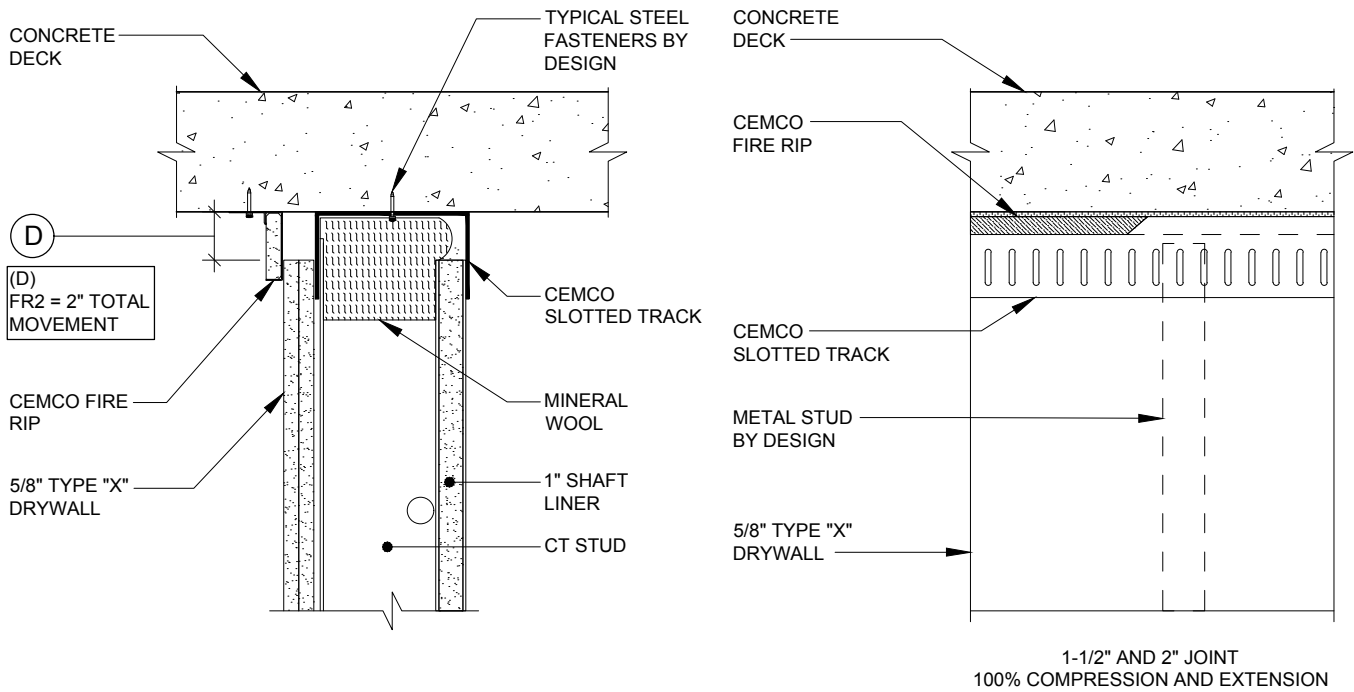

HW-D-0622 SHAFT WALL UNDER I-BEAM

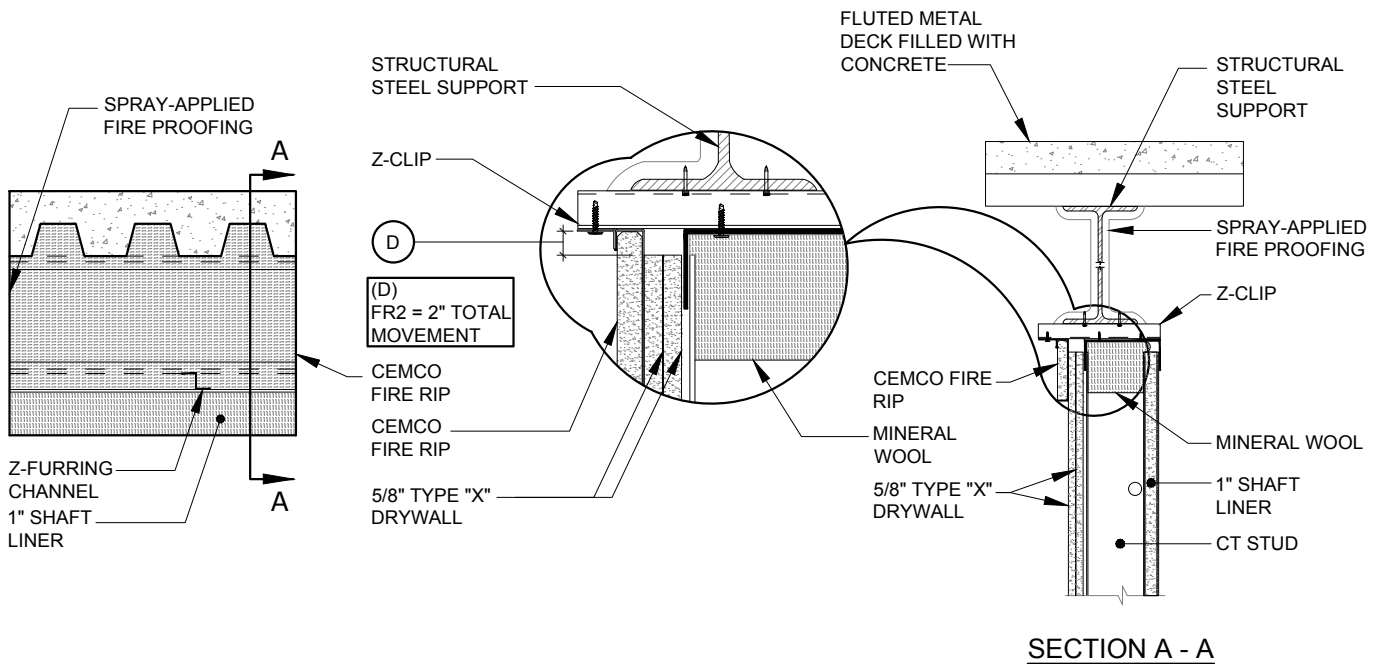

GENERAL NOTES:

1. INSTALL 3" WIDE, 4 PSF MINERAL WOOL COMPRESSED 33% FROM THE FACE OF THE SHAFT LINER TO THE INSIDE LEG OF THE TRACK ON ALL SHAFT WALL HEAD-OF-WALL JOINT SYSTEMS.
2. NO ADDITIONAL SEALANT OR SPRAY IS REQUIRED OVER MINERAL WOOL IN THE SHAFTWALL CAVITY.
3. ALL HEAD-OF-WALL TRACKS SHOULD HAVE A MINIMUM 1-1/2" FRONT LEG FOR DEFLECTION REQUIREMENTS.
4. ALL DEFLECTION CAPABILITIES ARE SPECIFIC TO THE CEMCO PRE-FORMED FIRESTOP CHECK REFERENCE GUIDE FOR MOVEMENT CAPABILITIES.

CT Fire-Rated Shaft Wall System Assemblies

Fire-Rating	GA Assembly	UL Assembly
1-Hour	GA WP 6800	U417
	GA WP 6801	U499
	GA WP 6802	V455
	GA WP 6850	V470
	GA WP 6851	V473
	GA WP 6904	V481
	GA WP 6905	V493
	GA WP 7024.3	W419

Fire-Rating	GA Assembly				UL Assembly		
2-Hour	GA WP 7040	GA WP 7059	GA WP 7067	GA WP 7096	U417	V455	V493
	GA WP 7051	GA WP 7060	GA WP 7073	GA WP 7097	U428	V470	W419
	GA WP 7052	GA WP 7061	GA WP 7076		U429	V472	W441
	GA WP 7054	GA WP 7062	GA WP 7077		U497	V473	
	GA WP 7054.4	GA WP 7064	GA WP 7078		U498	V481	
	GA WP 7056	GA WP 7065.2	GA WP 7079				
	GA WP 7057	GA WP 7065.5	GA WP 7080				
	GA WP 7058	GA WP 7066	GA WP 7084				

Fire-Rating	GA Assembly	UL Assembly	
3-Hour	GA WP 7422	U417	V481
	GA WP 7424	V470	W414
		V473	W419

Fire-Rating	GA Assembly	UL Assembly
4-Hour	GA WP 7640	V451
		V473
		W419

CT Sound Test Assemblies

Fire-Rating	Sound Test Assemblies
1-Hour	RAL-TL09-357 (STC 40-44)
2-Hour	RAL-TL93-181 (STC 50-54)
	RAL-TL09-358 (STC 50-54)
	RAL-TL09-360 (STC 50-54)

CT Shaft Wall System

Typical Details

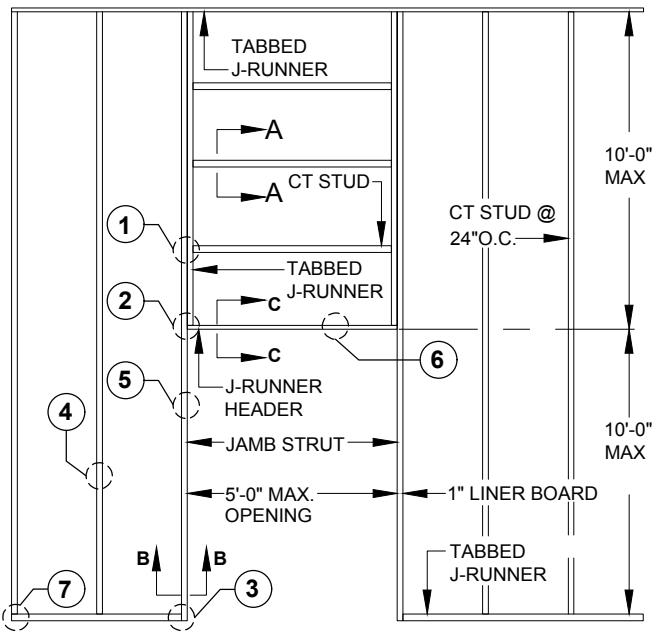

ELEVATOR DOOR ROUGH OPENING

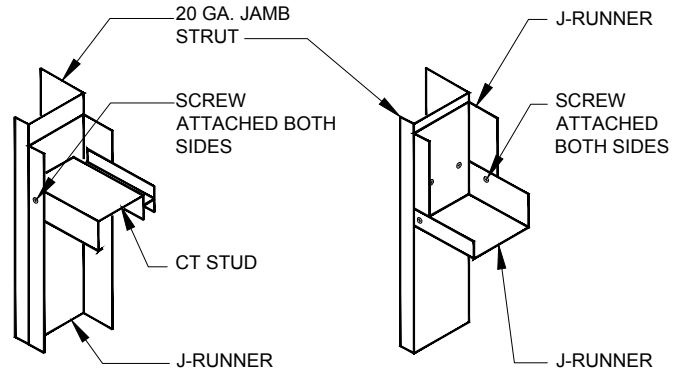

1 HORIZONTAL ATTACHMENT CT STUD TO J-RUNNER

2 HEADER DETAIL

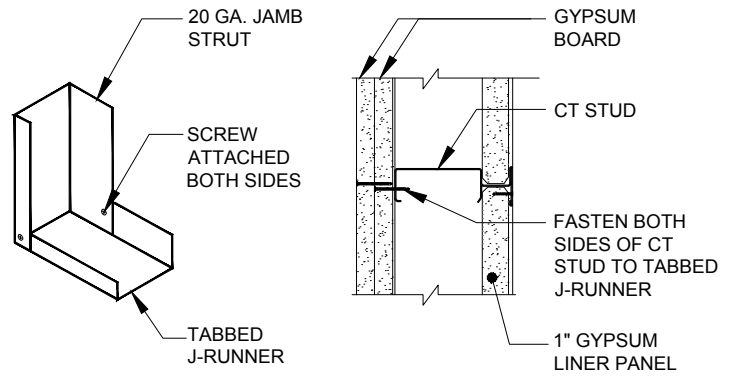

3 JAMB DETAIL

4 SECTION A-A

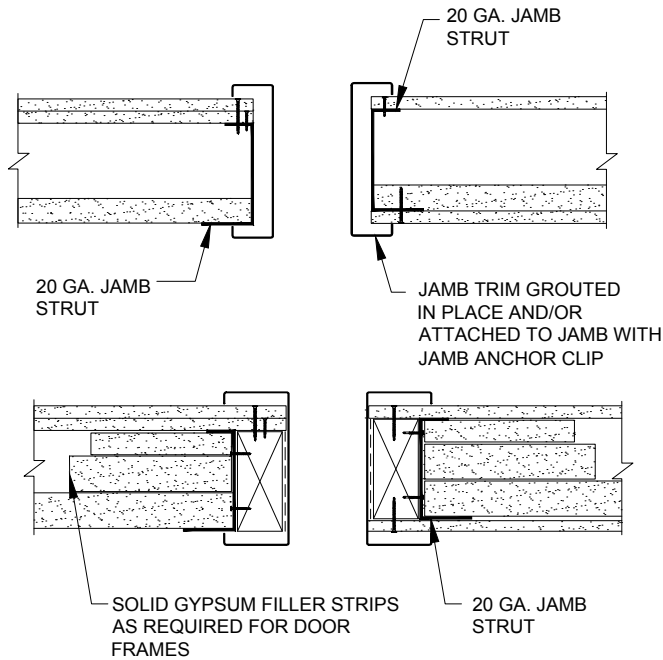

5 JAMB DETAIL SECTION B-B

6 JAMB DETAIL SECTION C-C

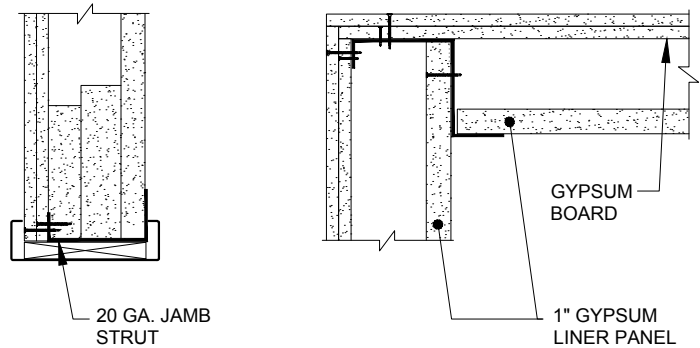

7 JL CORNER DETAIL

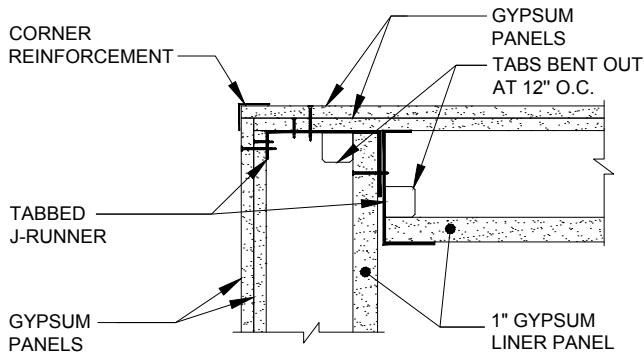

8 **OUTSIDE CORNER**

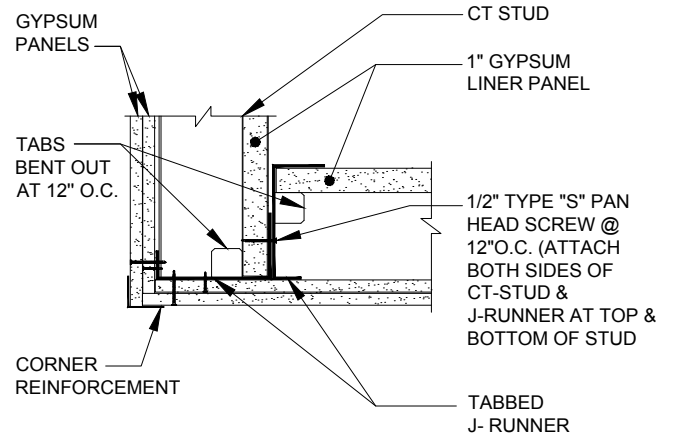

9 **INSIDE CORNER**

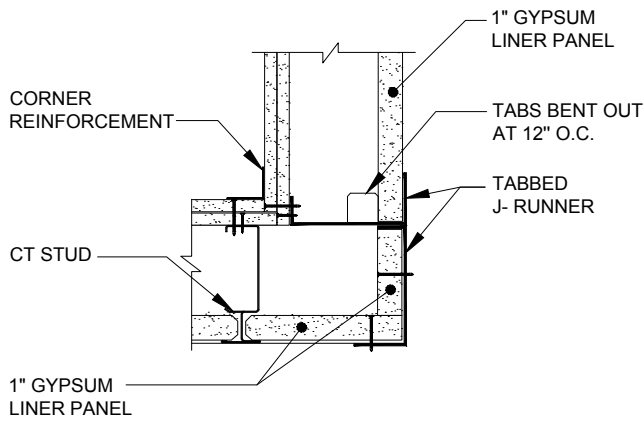

10 **INSIDE CORNER**

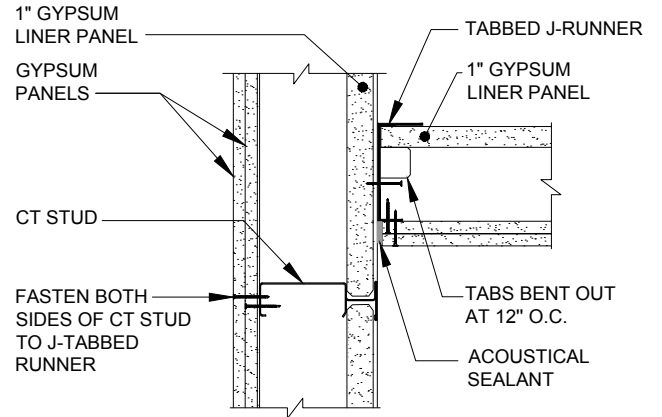

11 **WALL JUNCTION**

Shaft Wall Installation Instructions

1. Layout per construction drawings. Secure Tabbed J-Runner as perimeter framing on floor and plumb to ceiling, floor and sides. Attach using suitable fasteners not to exceed 24" on-center. Sealant may be required per the specific assembly.
2. Plan the stud layout at 24" on-center and adjust accordingly at either end to avoid the last CT stud installed is no closer than 8" from the end.
3. Cut the first 1" Shaftliner panel 3/4" to 1" less than the total height of the framed section. Plumb the panel flush against the Tabbed J-Runner and secure with 1-5/8" long #6 Type S screws 24" on-center.
4. Insert a CT Stud (cut 3/4" less than the overall height of the section) into the tracks (top and bottom) and fit tightly over the installed Shaftliner panel. Install top and bottom of the CT stud into both legs of the Tabbed J-Runner.
5. Install the next 1" Shaftliner board (cut 3/4" to 1" shorter than the overall height of the section) into the T-section of the CT Stud.
6. Continue to install successive CT studs and Shaftliner panels as described above until the wall section is closed. The final panel section may be secured using 1-5/8" long #6 Type S screws into the Tabbed J-Runner.
7. For doors, rough openings, and other large penetrations/openings, install Jamb Strut with a 3" back leg as perimeter framing for elevator doors and block cavity using 12" wide gypsum board filler strips per the door frame manufacturer's instructions.
8. 1" Shaftliner boards may be abutted, spliced, or stacked within the cavity with panels no shorter than 2' in length. Joints of adjacent Shaftliner panels should be alternately stacked or staggered to prevent a continuous joint (horizontal).
9. For a one sided finished vertical system: A 1-hour rating is achieved by installing a layer of 1/2" Type-C or 5/8" Type-X Classified gypsum board horizontally using 1" Type-S or S-12 screws spaced at 24" on-center ensuring the horizontal joints are offset from any splice joints in the shaftliner panels by no less than 12". For a 2-hour system, a face layer of 1/2" Type-C or 5/8" Type-X Classified gypsum board may be installed either horizontally or vertically over the 1-hour system using 1-5/8" Type S or S-12 screws spaced at 8" on-center.
10. For a two-sided finished vertical system: Each side may be installed either horizontally or vertically with 1" Type S or S-12 screws spaced at 8" on-center. Offset edges and ends on opposite sides by at least 24" on-center.
11. For a one-sided finished horizontal system: A 1-hour rating is achieved by installing one layer of 1/2" Type-C or 5/8" Type-X Classified gypsum board perpendicular to framing using 1" Type-S or S-12 screws spaced at 24" on-center ensuring long-edged joints are offset from any splice joints in the shaftliner panels by no less than 12". For a 2-hour system, a face layer of 1/2" Type-C or 5/8" Type-X Classified gypsum board may be installed either perpendicular or parallel to framing over the 1-hour system using 1-5/8" Type-S or S-12 screws spaced at 8" on-center.
12. If installing for HVAC ducts, consult with the HVAC engineer regarding the level of caulking and sealant required. All joints on the face layers must be taped and finished with joint compound meeting ASTM C 475. All penetration openings must be filled with approved fire-stopping sealants.



Expanding Your Solutions

Corporate Headquarters

13191 Crossroads Parkway North, Suite 325, City of Industry, CA 91746

P: 800.775.2362 | **F:** 626.330.7598

Southern California Manufacturing Facility

263 North Covina Lane, City of Industry, CA 91746

P: 800.775.2362 | **F:** 626.330.7598

Northern California Manufacturing Facility

1001-A Pittsburg Antioch Hwy, Pittsburg, CA 94565

P: 925.473.9340 | **F:** 925.473.9341

Denver Colorado Manufacturing Facility

490 Osage Street, Denver, CO 80204

P: 303.572.3626 | **F:** 303.572.3627

Fort Worth Texas Manufacturing Facility

8600 Will Rogers Blvd, Fort Worth, TX 76140

P: 817.568.1525 | **F:** 817.568.2759

www.cemcosteel.com

