



- Compliance to International Codes
- Compliance to State/Regional Codes

ICC-ES Evaluation Report

ESR-3336

Reissued January 2023

This report is subject to renewal January 2025.

DIVISION: 09 00 00—FINISHES
Section: 09 22 26—Suspension Systems
Section: 09 53 00—Acoustical Ceiling Suspension Assemblies

REPORT HOLDER:

CERTAINTEED CEILINGS CORPORATION

EVALUATION SUBJECT:

SUSPENDED CEILING FRAMING SYSTEMS AND SEISMIC PERIMETER CLIP

1.0 EVALUATION SCOPE

Compliance with the following codes:

- 2021, 2018, 2015, 2012, 2009 and 2006 *International Building Code*® (IBC)
- 2013 *Abu Dhabi International Building Code* (ADIBC)†

†The ADIBC is based on the 2009 IBC. 2009 IBC code sections referenced in this report are the same sections in the ADIBC.

For evaluation for compliance with codes adopted by the Los Angeles Department of Building and Safety (LADBS), see [ESR-3336 LABC Supplement](#).

For evaluation for compliance with codes adopted by California Office of Statewide Health Planning and Development (OSHPD) AKA: California Department of Health Care Access and Information (HCAI) and the Division of the State Architect (DSA), see [ESR-3336 CBC Supplement](#).

Properties evaluated:

- Structural
- Interior finish

2.0 USES

The CertainTeed suspended ceiling framing systems for acoustical tiles described in this report are exposed framing systems for use with lay-in acoustical tile suspended ceiling assemblies used in interior construction as noted in this report. The CertainTeed Seismic Perimeter Clips are used to connect main runners and cross tees to a wall angle or shadow molding in suspended ceiling framing systems for acoustical tiles. The suspended ceiling systems for gypsum wallboard

described in this report are suspended or direct-hung, concealed framing, ceiling assemblies used in interior and exterior applications.

3.0 DESCRIPTION

3.1 Suspended Ceiling Framing Systems:

3.1.1 Acoustical Tile Suspended Ceiling Systems:

The 15/16" EZ Stab Classic System (EZCS), 15/16" EZ Stab Classic Aluminum Capped System (EZACS), 15/16" EZ Stab Classic Environmental System (EZEVS), 9/16" EZ Stab Elite Narrow System (EZES), 15/16" EZ Stab Cleanroom System (EZCRS), 15/16" FireSecure Stab (FSS) Fire Rated, 15/16" FireSecure EZ Stab (FSEZ), 9/16" EZ Stab Bolt Slot (EZBS), 9/16" EZ Stab Tier Drop (EZTD), 15/16" All Aluminum System (ALC), 1 1/2" All Aluminum System (ALW), 15/16" All Aluminum Cleanroom System (ALCG), and 1 1/2" All Aluminum Cleanroom System (ALWG) acoustical suspended ceiling framing systems consist of main runners and cross tees for use with acoustical tile. The EZ systems have additional stitches on the webs and additional 0.219-inch (5.56 mm) diameter hanger holes through the bulb spaced 3-inches (76.2 mm) on center. These additional hanger holes in the bulb are as suitable for use as the standard hanger holes in the web of the profile. See Figure 15. Profiles of framing members are shown in Figure 1.

3.1.2 Drywall Grid Framing System: The 1 1/2" Drywall Grid System (DWS) and 1 1/2" EZ Drywall Grid System (EZDWS) consists of main and cross runner framing systems as shown in Table 1 for use with gypsum wallboard attached to the bottom of framing members. Profiles of framing members are shown in Figure 1.

3.2 Seismic Perimeter Clip:

The Seismic Perimeter Clip (CTSPC-2) as shown in Figure 2 is used to connect main runners and cross tees to the wall angle at the ceiling perimeter. The clip is manufactured from 0.030-inch-thick (0.76 mm), cold-rolled steel complying with ASTM A653, with a hot-dipped galvanized coating designation of G30. The CTSPC-2 may have two pre-drilled holes used for screw attachment.

3.3 Materials:

3.3.1 Framing Members: Main runners and cross tees are roll-formed from steel conforming to ASTM A653 and having a hot-dipped galvanized coating designation of

G30 or higher. The runners and tees are also available with powder coating. The bottom, exposed flange of both main runners and cross tees is covered with a painted capping made from steel or aluminum. Table 1 lists the profile shape designations, member type (main runner or cross tee), lengths, heights, metal thicknesses, maximum spans, allowable loading and, for main runners, the classification as either intermediate- or heavy-duty according to ASTM C635.

3.3.2 Hanger and Bracing Wires: Wires for suspended ceiling framing members and fixtures must comply with ASTM C636 as referenced in 2021, 2018, 2015, 2012 and 2009 IBC Section 808.1.1.1 (2006 IBC Section 803.9.1.1) and Section 13.5.6 of ASCE 7 as referenced in IBC Section 2506.2.1.

4.0 DESIGN AND INSTALLATION

4.1 Suspended Ceiling Framing Systems for Acoustical Tiles:

4.1.1 General: The suspended ceiling framing systems for acoustical tiles must be installed with acoustical tiles in accordance with this report and the manufacturer's published installation instructions. The suspended ceiling framing systems must be installed in accordance with 2021, 2018, 2015, 2012 and 2009 IBC Sections 808, 1613 and 2506.2.1 (2006 IBC Sections 803.9, 1613 and 2506.2.1). The minimum ultimate tension and compression capacity of framing member connections is 180 pounds (800 N).

4.1.2 Main Runners: The maximum applied loads for main runners must be less than or equal to the allowable capacities listed in Table 1 of this report.

4.1.3 Cross Tees: The maximum applied load for cross tees must be less than or equal to the allowable capacities listed in Table 1.

4.1.4 Seismic Design Requirements: Seismic design and installation details of the ceiling system, including lighting fixtures and mechanical services, must be in accordance with Section 13.5.6 of ASCE 7 as referenced in IBC Section 1613, except as noted in Section 4.2 of this report, for systems not exceeding 4 lb/ft² (19.5 kg/m²). Main runners classified as heavy-duty can be used in Seismic Design Categories A, B, C, D, E and F. Main runners classified as intermediate-duty can only be used in Seismic Design Categories A, B and C. Partitions must be laterally supported as required by Section 13.5.8 of ASCE 7, as referenced in IBC Section 1613.

4.2 Alternate Suspended Ceiling Framing Systems for Acoustical Tiles Using Seismic Perimeter Clip:

4.2.1 Alternate Installation No. 1 for Seismic Design Categories D, E and F: In this installation, the ⁹/₁₆" EZ Stab Elite Narrow System, ¹⁵/₁₆" EZ Stab Classic System, ¹⁵/₁₆" EZ Stab Classic Environmental System, ¹⁵/₁₆" EZ Stab Classic Aluminum Capped System, ¹⁵/₁₆" FireSecure EZ Stab and ¹⁵/₁₆" EZ Stab Cleanroom System main runners and cross tees must be those described in Section 3.3.1. The main runner must be classified as Heavy Duty in Table 1 of this report. The maximum total ceiling weight permitted is 2.57 lb/ft² (12.56 kg/m²). The Seismic Perimeter Clip (CTSPC-2) is used to connect main runners and cross tees to the perimeter wall angle or shadow molding. The Seismic Perimeter Clip must be fixed to the framing member on two adjacent orthogonal walls and allow for free movement on the two opposing walls. Figure 3A and 7A show the fixed wall setup and Figure 4A and 6A show the free wall setup. As an

alternate to the perimeter runner being fixed through the Seismic Perimeter Clip, the perimeter runner may be fastened through the wall angle with a ¹/₈-inch-diameter (3.2 mm) by ¹/₄-inch-long aluminum pop (blind) rivet, as shown in Figure 3A. Wall angle (WA14-14 or WA15-15) or shadow molding (SM1000) is used in lieu of the 2-inch-wide (51 mm) wall angle required by ASTM E580 and Section 13.5.6.2.2 of ASCE 7-16 for the 2021 and 2018 IBC [ASCE 7-10 for the 2015 and 2012 IBC and Section 13.5.6.2.2 of ASCE 7-05 for the 2009 and 2006 IBC] for Seismic Design Categories D, E and F. The ceiling system must be installed as prescribed by the applicable code except for the use of the Seismic Perimeter Clip, the wall angle (WA14-14 or WA15-15) or shadow molding (SM1000) and the elimination of the stabilizer bars.

The Seismic Perimeter Clip is installed by pushing the back tabs of the clip over the vertical hem of the wall angle or shadow molding. On the two adjacent fixed walls, the perimeter clip must be attached to the framing member by a No. 7 by ⁷/₁₆-inch-long (11.1 mm) pan-head sharp-point screw fastened into the bulb or web of the runner and provide no clearance between the terminal runner end and the wall angle or shadow molding. On the free walls, the clips must allow for a minimum ³/₄-inch (19.1 mm) movement of the terminal runner end towards and away from the wall. Under the 2021 and 2018 IBC, as required by Section 13.5.6.2.2 of ASCE 7-16, Seismic Perimeter Clips must be screwed to the wall angle or shadow molding with a total of two (2) screws, and the wall angle or shadow molding must be positively attached to the wall studs or other supporting structure. Seismic Perimeter Clips installed in this manner are used in lieu of the stabilizer bars required in Section 5 of ASTM E580 (for the 2021, 2018, 2015 and 2012 IBC) and CISCA 3-4 (for the 2009 and 2006 IBC). ASTM E580 is referenced in ASCE 7-16 and ASCE 7-10, Section 13.5.6.2.2; and CISCA 3-4 is referenced in ASCE 7-05, Section 13.5.6.2.2, which are referenced in IBC Section 1613. The assembly described in this section is equivalent to that required by CISCA 3-4 and Section 5 of ASTM E580.

4.2.2 Alternate Installation No. 2 for Seismic Design Categories D, E and F: In this installation, the ⁹/₁₆" EZ Stab Elite Narrow System, ¹⁵/₁₆" EZ Stab Classic System, ¹⁵/₁₆" EZ Stab Classic Environmental System, ¹⁵/₁₆" EZ Stab Classic Aluminum Capped System, ¹⁵/₁₆" FireSecure EZ Stab and ¹⁵/₁₆" EZ Stab Cleanroom System main runners and cross tees must be those described in Section 3.3.1. The main runner must be classified as Heavy Duty in Table 1 of this report. The maximum total ceiling weight permitted is 4 lb/ft² (19.55 kg/m²). The Seismic Perimeter Clip (CTSPC-2) is used to connect main runners and cross tees to the perimeter wall angle or shadow molding. The Seismic Perimeter Clip must be fixed to the framing member on two adjacent orthogonal walls and allow for free movement on the two opposing walls. Figure 3B and 7B show the fixed wall setup and Figure 4B and 6B show the free wall setup. Wall angle (WA14-14 or WA15-15) or shadow molding (SM1040 or SM1050) is used in lieu of the 2-inch-wide (51 mm) wall angle required by ASTM E580 and Section 13.5.6.2.2 of ASCE 7-16 for the 2021 and 2018 IBC [ASCE 7-10 for the 2015 and 2012 IBC and Section 13.5.6.2.2 of ASCE 7-05 for the 2009 and 2006 IBC] for Seismic Design Categories D, E and F. The ceiling system must be installed as prescribed by the applicable code except for the use of the Seismic Perimeter Clip, the wall angle (WA14-14 or WA15-15) or shadow molding (SM1040 or SM1050) and the elimination of the stabilizer bars.

The Seismic Perimeter Clip is installed by pushing the back tabs of the clip over the vertical hem of the wall angle or shadow molding. The Seismic Perimeter Clip must be fastened to the wall angle or shadow molding using two (2) No. 7 by $\frac{7}{16}$ -inch-long pan-head sharp-point screws. On the two adjacent fixed walls, the perimeter clip must be attached to the framing member by a No. 7 by $\frac{7}{16}$ -inch-long (11.1 mm) pan-head sharp-point screw fastened into the bulb or web of the runner and provide no clearance between the terminal runner end and the wall angle or shadow molding. On the free walls, the clips must allow for a minimum $\frac{3}{4}$ -inch (19.1 mm) movement of the terminal runner end towards and away from the wall. Under the 2021 and 2018 IBC, as required by Section 13.5.6.2.2 of ASCE 7-16, Seismic Perimeter Clips must be screwed to the wall angle or shadow molding with a total of two (2) screws, and the wall angle or shadow molding must be positively attached to the wall studs or other supporting structure. Seismic Perimeter Clips installed in this manner are used in lieu of the stabilizer bars required in Section 5 of ASTM E580 (for the 2021, 2018, 2015 and 2012 IBC) and CISCA 3-4 (for the 2009 and 2006 IBC). ASTM E580 is referenced in ASCE 7-16 and ASCE 7-10, Section 13.5.6.2.2; and CISCA 3-4 is referenced in ASCE 7-05, Section 13.5.6.2.2, which are referenced in IBC Section 1613. The assembly described in this section is equivalent to that required by CISCA 3-4 and Section 5 of ASTM E580.

4.2.3 Alternate Installation No. 3 for Seismic Design Categories D, E and F: In this installation, the $\frac{9}{16}$ " EZ Stab Bolt Slot and $\frac{9}{16}$ " EZ Stab Tier Drop main runners and cross tees must be those described in Section 3.3.1. The main runner must be classified as Heavy Duty in Table 1 of this report. The maximum total ceiling weight permitted is 4 lb/ft² (19.55 kg/m²). The Seismic Perimeter Clip (CTSPC-2) is used to connect main runners and cross tees to the perimeter wall angle or shadow molding. The Seismic Perimeter Clip (CTSPC-2) must be fixed to the framing member on two adjacent orthogonal walls and allow for free movement on the two opposing walls. Figures 8 and 11 show the fixed wall setup and Figures 10 and 13 show the free wall setup. Wall angle (WA14-14 or WA15-15) or shadow molding (SM1020, SM1040 or SM1050) is used in lieu of the 2-inch-wide (51 mm) wall angle required by ASTM E580 and Section 13.5.6.2.2 of ASCE 7-16 for the 2021 and 2018 IBC [ASCE 7-10 for the 2015 and 2012 IBC and Section 13.5.6.2.2 of ASCE 7-05 for the 2009 and 2006 IBC] for Seismic Design Categories D, E and F. The ceiling system must be installed as prescribed by the applicable code except for the use of the Seismic Perimeter Clip (CTSPC-2), wall angle (WA 15-15 or WA14-14) or shadow molding (SM1020, SM1040 or SM1050) and the elimination of the stabilizer bars.

The Seismic Perimeter Clip (CTSPC-2) is installed by pushing the back tabs of the clip over the vertical hem of the wall angle or shadow molding. When using the CTSPC-2 clip, the clip must be fastened to the wall angle or shadow molding using two (2) No. 7 by $\frac{7}{16}$ -inch-long (11.1 mm) pan-head sharp-point screws. On the two adjacent fixed walls, the perimeter clip must be attached to the framing member by a No. 7 by $\frac{7}{16}$ -inch-long (11.1 mm) pan-head sharp-point screw fastened into the bulb or web of the runner and provide no clearance between the terminal runner end and the wall angle or shadow molding. On the free walls, the clips must allow for a minimum $\frac{3}{4}$ -inch (19.1 mm) movement of the terminal runner end towards and away from the wall. Under the 2021 and 2018 IBC, as required by Section 13.5.6.2.2 of ASCE 7-16, Seismic Perimeter Clips must

be screwed to the wall angle or shadow molding with a total of two (2) screws, and the wall angle or shadow molding must be positively attached to the wall studs or other supporting structure. Seismic Perimeter Clips (CTSPC-2) installed in this manner are used in lieu of the stabilizer bars required in Section 5 of ASTM E580 (for the 2021, 2018, 2015 and 2012 IBC) and CISCA 3-4 (for the 2009 and 2006 IBC). ASTM E580 is referenced in ASCE 7-16 and ASCE 7-10, Section 13.5.6.2.2; and CISCA 3-4 is referenced in ASCE 7-05, Section 13.5.6.2.2, which are referenced in IBC Section 1613. The assembly described in this section is equivalent to that required by CISCA 3-4 and Section 5 of ASTM E580.

4.2.4 Alternate Installation No. 4 for Seismic Design Categories A, B and C: In this installation, the $\frac{9}{16}$ " EZ Stab Elite Narrow System, $\frac{15}{16}$ " EZ Stab Classic System, $\frac{15}{16}$ " EZ Stab Classic Environmental System, $\frac{15}{16}$ " EZ Stab Classic Aluminum Capped System, $\frac{15}{16}$ " EZ Stab Cleanroom System, $\frac{15}{16}$ " FireSecure EZ Stab and $\frac{15}{16}$ " FireSecure Stab Fire Rated System main runners and cross tees must be those described in Section 3.3.1. The Seismic Perimeter Clip (CTSPC-2) may be used in lieu of stabilizer bars in suspended ceiling installations regulated by Section 4 of ASTM E580 and CISCA 0-2. The Seismic Perimeter Clips (CTSPC-2) are placed at the intersections of main runners and wall angle (WA14-14 or WA15-15) or shadow molding (SM1020) and cross tees and wall angle (WA14-14 or WA15-15) or shadow molding (SM1020). The Seismic Perimeter Clip (CTSPC-2) is installed by pushing the back tabs of the clip over the vertical hem of the wall angle or shadow molding. When using wall angles, two adjacent walls are fixed with a No. 7 by $\frac{7}{16}$ -inch-long (11.1 mm) pan-head sharp-point screw through the bulb or web of the framing member. The two opposing walls are free and the installation of the clips must allow for minimum $\frac{3}{8}$ -inch (9.5 mm) movement of the terminal runner end towards and away from the wall. When using the shadow molding (SM1020), the runner ends must not be fixed or screwed to the seismic perimeter clip (CTSPC-2) and the installation of the clips must allow for minimum $\frac{3}{8}$ -inch (9.5 mm) movement of the runner end towards and away from the wall as shown in Figure 5. The maximum ceiling weight permitted is 2.28 lb/ft² (11.12 kg/m²). Seismic Perimeter Clips (CTSPC-2) installed in this manner are used in lieu of stabilizer bars required by Section 4 of ASTM E580 and CISCA 0-2. The ceiling system must be installed as prescribed by the applicable code except for the use of the Seismic Perimeter Clip (CTSPC-2) and the elimination of the stabilizer bars. The assembly described in this section is equivalent to that required by CISCA 0-2 (for the 2009 and 2006 IBC) and Section 4 of ASTM E580 (for the 2021, 2018, 2015 and 2012 IBC).

4.2.5 Alternate Installation No. 5 for Seismic Design Categories A, B and C: In this installation, the $\frac{9}{16}$ " EZ Stab Bolt Slot and $\frac{9}{16}$ " EZ Stab Tier Drop main runners and cross tees must be those described in Section 3.3.1. The Seismic Perimeter Clip (CTSPC-2) may be used in lieu of stabilizer bars in suspended ceiling installations regulated by Section 4 of ASTM E580 and CISCA 0-2. The Seismic Perimeter Clips (CTSPC-2) are placed at the intersections of main runners and wall angle (WA14-14 or WA15-15) or shadow molding (SM1040 or SM1050) and cross tees and wall angle (WA14-14 or WA15-15) or shadow molding (SM1040 or SM1050). The Seismic Perimeter Clip (CTSPC-2) is installed by pushing the back tabs of the clip over the vertical hem of the wall angle or shadow molding (SM1040 or SM1050). When using the CTSPC-2 clip, the clip must be fastened to the wall angle or shadow molding using two (2) No. 7 by $\frac{7}{16}$ -inch long

(11.1 mm) pan-head sharp-point screws. On two adjacent walls the runner ends are screwed to the seismic perimeter clips with a No. 7 by $7/16$ -inch long (11.1 mm) pan-head sharp-point screw through the bulb or web of the runner (see Figures 8 and 11). The two opposing walls are free and the installation of the clips must allow for minimum $3/8$ -inch (9.5 mm) movement of the terminal runner end towards and away from the wall, (see Figures 9 and 12). The maximum ceiling weight permitted is 2.5 lb/ft² (12.22 kg/m²). Seismic Perimeter Clips (CTSPC-2) installed in this manner are used in lieu of stabilizer bars required by Section 4 of ASTM E580 and CISCA 0-2. The ceiling system must be installed as prescribed by the applicable code except for the use of the Seismic Perimeter Clip (CTSPC-2) and the elimination of the stabilizer bars. The assembly described in this section is equivalent to that required by CISCA 0-2 (for the 2009 and 2006 IBC) and Section 4 of ASTM E580 (for the 2021, 2018, 2015 and 2012 IBC).

4.3 Suspended Ceiling Systems for Gypsum Wallboard: In this installation, the main and cross runners must be as described in Section 3.1.2. The installation must be in accordance with Section 4.1, except the ceiling must be designed for seismic loads required under Chapter 13 of ASCE 7-16 for the 2021 and 2018 IBC [ASCE 7-10 for the 2015 and 2012 IBC (ASCE 7-05 for the 2009 and 2006 IBC)], as referenced by IBC Section 1613. The ceiling weight must not exceed 4 psf (19.5 kg/m²). The ceiling weight may be increased up to 10 psf (48.82 kg/m²), when installed as indicated in Tables 2 through 5 of this report. Suspended ceilings constructed of gypsum boards, screw or nail attached to suspended members that support a ceiling on one level extending from wall to wall are exempt from lateral load design requirements of ASTM E580 and CISCA Seismic Zones 2, 3 and 4.

4.3.1 Gypsum Wallboard Attachment: Gypsum wallboard must be installed and fastened to the ceiling framing system in accordance with IBC Section 2508.

4.4 Special Inspection:

Where special inspections are required by the building official, the suspended ceilings in Seismic Design Categories C, D, E and F, shall be subjected to periodic special inspections during the installation of the suspended ceiling systems and their anchorage in accordance with the following requirements:

- For installations in accordance with Section 4.2 of this report, special inspection must be conducted as required by the building official during enforcement of the 2021, 2018 and 2015 IBC Sections 1704.5, 1705.1.1 and 1705.13.2 [2012 IBC Sections 1705.1.1, 1705.11.4 and 1705.12, Item 3 and 1705.12.3: 2009 IBC Sections, 1704.15, 1708.1, Item 3: 2006 IBC Section 1704.13, 1708.4 and Item 3 of 1708.1; 2006 IBC Sections 1704.13, 1708.5 and Item 3 of Section 1708.2)], as applicable.
- For installations in accordance with Sections 4.1.4 and 4.3 of this report, special inspection must be conducted as indicated in Section 13.5.6.2.2 (h) of ASCE 7-05 and 2009 IBC Section 1705.3.4, item 3 for the 2009 IBC; Section 13.5.6.2.2 (h) of ASCE 7-05 and 2006 IBC Section 1705.3, Item 4.3 for the 2006 IBC, as applicable.
- The special inspector must verify that the ceiling system is as described in this report, and complies with this report, and with the approved construction documents.

Where special inspections are required by the building official, a statement of special inspections must be provided as required in 2021, 2018, 2015 and 2012 IBC Sections 1704.3 [2009 IBC Sections 1705.2 and 1705.3; and 2006 IBC Sections 1705.2 and 1705.3, as applicable].

5.0 CONDITIONS OF USE

The CertainTeed suspended ceiling systems described in this report comply with, or are suitable alternatives to what is specified in, those codes listed in Section 1.0 of this report, subject to the following conditions:

- 5.1 The ceiling suspension main runners and cross tees, and the Seismic Perimeter Clip, must be manufactured and installed in accordance with this report and the manufacturer's published installation instructions. This report governs in the event of any conflict with the manufacturer's installation instructions.
- 5.2 Design loads and span lengths for main runners and cross tees must be as listed in Table 1 of this report.
- 5.3 Suspended ceiling systems must be designed in accordance with ASCE 7, Section 13.5.6, as referenced by IBC section 1613. The documents must be prepared by a registered design professional where required by statutes of jurisdiction in which the project is to be constructed.
- 5.4 Periodic special inspections and a statement of special inspections must be provided in accordance with Section 4.4 of this report.
- 5.5 The ceiling framing system must not be used to provide lateral support for walls or partitions except as provided for in ASCE 7, Section 13.5.8.1, as referenced in IBC Section 1613.
- 5.6 The ceiling system must be braced to resist seismic forces as determined from Section 1613 of the IBC.
- 5.7 The supporting construction for the ceiling system has not been evaluated and is outside the scope of this report. The code official must approve the floor or roof construction supporting the suspended ceiling system.
- 5.8 The ceiling systems are limited to ceilings not considered accessible in accordance with Item 29 of 2021 IBC Table 1607.1, Item 28 of 2018, 2015 and 2012 IBC Table 1607.1 (Item 31 of 2009 IBC Table 1607.1, or Item 32 of 2006 IBC Table 1607.1).
- 5.9 The ceiling systems are limited to interior applications. Exterior ceiling installations must be designed for wind loads.
- 5.10 Lay-in ceiling panels must be justified to the satisfaction of the code official as complying with the interior finish requirements of Chapter 8 of the IBC.
- 5.11 Lighting fixtures and mechanical services must be as described in Section 4 of this report.

6.0 EVIDENCE SUBMITTED

- 6.1 Data in accordance with the ICC-ES Acceptance Criteria for Suspended Ceiling Framing Systems (AC368), dated November 2019 (editorially revised March 2021).
- 6.2 Data in accordance with the ICC-ES Acceptance Criteria for Seismic Certification by Shake-table Testing of Nonstructural Components (AC156), dated October 2010 (editorially revised December 2020).

7.0 IDENTIFICATION

7.1 Cartons of ceiling suspension system framing members, Seismic Perimeter Clips and accessories are identified with the name of CertainTeed Ceilings and the evaluation report number (ESR-3336).

7.2 The report holder's contact information is the following:

CERTAINTEED CEILINGS CORPORATION

**20 MOORES ROAD
MALVERN, PENNSYLVANIA 19355
(610) 651-5806**

www.certainteed.com
ceilingtechnicalservices@certainteed.com

TABLE 1—DIMENSIONS AND ALLOWABLE LOADS FOR SUSPENDED CEILING FRAMING MEMBERS⁵

ITEM NUMBER	MEMBER TYPE	LOAD CLASSIFICATION	NOMINAL LENGTH OF MEMBER (inches)	HEIGHT OF MEMBER (inches)	METAL THICKNESS (inch)	MAXIMUM SPAN (inches)	ALLOWABLE UNIFORM LOAD (plf)	ALLOWABLE CONCENTRATED LOAD AT MIDSPAN (lbf) ¹
<i>9/16" EZ Stab Elite Narrow System</i>								
EZES 3000M-12-18	Main Runner	Intermediate Duty	118.11	1.5	0.018	48	13.15	32.88
EZES 3600M-12-18	Main Runner	Intermediate Duty	141.73	1.5	0.018	48	13.15	32.88
EZES 12-12-18	Main Runner	Intermediate Duty ⁶	144	1.5	0.018	36	25.7	48.19
EZES 12-12-18	Main Runner	Intermediate Duty	144	1.5	0.018	48	13.15	32.88
EZES 12-12-18	Main Runner	Intermediate Duty ⁶	144	1.5	0.018	60	5.3	16.56
EZES 12-12-19	Main Runner	Heavy Duty ⁶	144	1.687	0.019	36	31.52	59.10
EZES 12-12-19	Main Runner	Heavy Duty	144	1.687	0.019	48	17.97	44.93
EZES 12-12-19	Main Runner	Heavy Duty ⁶	144	1.687	0.019	60	9.14	28.56
EZES 1-12-12	Cross Tee	—————	12	1.5	0.012	12	210.53	131.58
EZES 2-12-19	Cross Tee	—————	24	1.687	0.019	24	50	62.50
EZES 500M-12-12	Cross Tee	—————	19.69	1.5	0.012	19.69	54.72	56.12
EZES 600M-12-12	Cross Tee	—————	23.62	1.5	0.012	23.62	29.68	36.51
EZES 2-12-12	Cross Tee	—————	24	1.5	0.012	24	27.97	34.96
EZES 750M-12-12	Cross Tee	—————	29.53	1.5	0.012	29.53	14.1	21.69
EZES 1200M-12-12	Cross Tee	—————	47.25	1.5	0.012	47.25	8.66	21.31
EZES 1500M-12-12	Cross Tee	—————	59.06	1.5	0.012	59.06	4.66	14.33
EZES 1500M-12-12-5S	Cross Tee	—————	59.06	1.5	0.012	59.06	4.66	14.33
EZES 4-12-12	Cross Tee	—————	48	1.5	0.012	48	8.44	21.09
EZES 5-12-12	Cross Tee	—————	60	1.5	0.012	60	4.44	13.88
EZES 5-12-12-3S	Cross Tee	—————	60	1.5	0.012	60	4.44	13.88
EZES 6-12-12	Cross Tee	—————	72	1.5	0.012	72	2.76	10.35
EZES 8-12-12	Cross Tee	—————	96	1.5	0.012	96	1.00	5.00
EZES 2-12-19	Cross Tee	—————	24	1.687	0.019	24	17.97	44.93
EZES 4-12-19	Cross Tee	—————	48	1.687	0.019	48	17.97	44.93
EZES 6-12-19	Cross Tee	—————	72	1.687	0.019	72	5.14	19.28
EZES 8-12-19	Cross Tee	—————	96	1.687	0.019	96	2	10.00
<i>15/16" EZ Stab Classic System</i>								
EZCS 10-12-15	Main Runner	Intermediate Duty	120	1.5	0.015	48	13.56	33.90
EZCS 10-12-15-12S	Main Runner	Intermediate Duty	120	1.5	0.015	48	13.56	33.90
EZCS 11.67-12-15	Main Runner	Intermediate Duty	140	1.5	0.015	48	13.56	33.90
EZCS 3000MM-12-15	Main Runner	Intermediate Duty	118.11	1.5	0.015	48	13.56	33.90
EZCS 3600MM-12-15	Main Runner	Intermediate Duty	141.73	1.5	0.015	48	13.56	33.90
EZCS 12-12-15	Main Runner	Intermediate Duty ⁶	144	1.5	0.015	36	27.2	51.00
EZCS 12-12-15	Main Runner	Intermediate Duty	144	1.5	0.015	48	13.56	33.9
EZCS 12-12-15	Main Runner	Intermediate Duty ⁶	144	1.5	0.015	60	6.3	19.69
EZCS 12-12-20	Main Runner	Intermediate Duty ⁶	144	1.5	0.020	36	31.01	58.14
EZCS 12-12-20	Main Runner	Heavy Duty	144	1.5	0.020	48	16.58	41.45
EZCS 3600M-12-20	Main Runner	Heavy Duty	141.73	1.5	0.020	48	16.58	41.45
EZCS 12-12-20	Main Runner	Heavy Duty ⁶	144	1.5	0.020	60	8.31	25.97
EZCS 1-12-12	Cross Tee	—————	12	1.5	0.012	12	63.1	39.44
EZCS 500MM-12-12	Cross Tee	—————	19.69	1.5	0.012	19.69	69.44	71.21
EZCS 1.67-12-12	Cross Tee	—————	20	1.5	0.012	20	69.44	72.33
EZCS 600MM-12-12	Cross Tee	—————	23.62	1.5	0.012	23.62	35.31	43.44
EZCS 2-12-12	Cross Tee	—————	24	1.5	0.012	24	34.8	43.51

TABLE 1—DIMENSIONS AND ALLOWABLE LOADS FOR SUSPENDED CEILING FRAMING MEMBERS⁵ (Continued)

ITEM NUMBER	MEMBER TYPE	LOAD CLASSIFICATION	NOMINAL LENGTH OF MEMBER (inches)	HEIGHT OF MEMBER (inches)	METAL THICKNESS (inch)	MAXIMUM SPAN (inches)	ALLOWABLE UNIFORM LOAD (plf)	ALLOWABLE CONCENTRATED LOAD AT MIDSPAN (lbf) ¹
EZCS 750MM-12-12	Cross Tee	—————	29.53	1.5	0.012	29.53	23.58	36.27
EZCS 2.5-12-12	Cross Tee	—————	30	1.5	0.012	30	22.89	35.77
EZCS 1200MM-12-12	Cross Tee	—————	47.25	1.5	0.012	47.25	9.94	24.46
EZCS 4-12-12	Cross Tee	—————	48	1.5	0.012	48	9.67	24.16
EZCS 1500MM-12-12	Cross Tee	—————	59.06	1.5	0.012	59.06	6.21	19.10
EZCS 1500MM-12-12-5S	Cross Tee	—————	59.06	1.5	0.012	59.06	6.21	19.10
EZCS 5-12-12	Cross Tee	—————	60	1.5	0.012	60	6.00	18.75
EZCS 5-12-12-3S	Cross Tee	—————	60	1.5	0.012	60	6.00	18.75
EZCS 6-12-12	Cross Tee	—————	72	1.5	0.012	72	3.43	12.86
EZCS 8-12-12	Cross Tee	—————	96	1.5	0.012	48	10.48	26.19
EZCS 8-12-12	Cross Tee	—————	96	1.5	0.012	96	1.5	7.50
EZCS 2-12-20	Cross Tee	—————	24	1.5	0.020	24	50	62.50
EZCS 4-12-20	Cross Tee	—————	48	1.5	0.020	48	16.58	41.45
EZCS 6-12-20	Cross Tee	—————	72	1.5	0.020	72	4.71	17.66
EZCS 8-12-20	Cross Tee	—————	96	1.5	0.020	96	2	10.00
¹⁵ / ₁₆ " EZ Stab Classic Aluminum Capped System								
EZACS 12-12-20	Main Runner	Heavy Duty ⁶	144	1.5	0.020	36	29.9	56.06
EZACS 12-12-20	Main Runner	Heavy Duty	144	1.5	0.020	48	16.7	41.72
EZACS 12-12-20	Main Runner	Heavy Duty ⁶	144	1.5	0.020	60	6.7	20.94
EZACS 12-12-15	Main Runner	Intermediate Duty ⁶	144	1.5	0.015	36	23.5	44.06
EZACS 12-12-15	Main Runner	Intermediate Duty	144	1.5	0.015	48	12.05	30.13
EZACS 12-12-15	Main Runner	Intermediate Duty ⁶	144	1.5	0.015	60	5.00	15.63
EZACS 2-12-12	Cross Tee	—————	24	1.5	0.012	24	36.14	45.18
EZACS 4-12-12	Cross Tee	—————	48	1.5	0.012	48	8.98	22.44
¹⁵ / ₁₆ " EZ Stab Classic Environmental Stab System ²								
EZEVS 12-12-20-G60	Main Runner	Heavy Duty ⁶	144	1.5	0.020	36	29.9	56.06
EZEVS 12-12-20-G60	Main Runner	Heavy Duty	144	1.5	0.020	48	16.7	41.72
EZEVS 12-12-20-G60	Main Runner	Heavy Duty ⁶	144	1.5	0.020	60	6.7	20.94
EZEVS 12-12-15-G60	Main Runner	Intermediate Duty ⁶	144	1.5	0.015	36	23.5	44.06
EZEVS 12-12-15-G60	Main Runner	Intermediate Duty	144	1.5	0.015	48	12.05	30.13
EZEVS 12-12-15-G60	Main Runner	Intermediate Duty ⁶	144	1.5	0.015	60	5.00	15.63
EZEVS 2-12-12-G60	Cross Tee	—————	24	1.5	0.012	24	36.14	45.18
EZEVS 4-12-12-G60	Cross Tee	—————	48	1.5	0.012	48	8.98	22.44
EZEVS 4-12-20-G60	Cross Tee	—————	48	1.5	0.020	48	16.7	41.72
EZEVS 12-12-20-G90	Main Runner	Heavy Duty ⁶	144	1.5	0.020	36	29.9	56.06
EZEVS 12-12-20-G90	Main Runner	Heavy Duty	144	1.5	0.020	48	16.7	41.72
EZEVS 12-12-20-G90	Main Runner	Heavy Duty ⁶	144	1.5	0.020	60	6.7	20.94
EZEVS 12-12-15-G90	Main Runner	Intermediate Duty ⁶	144	1.5	0.015	36	23.5	44.06
EZEVS 12-12-15-G90	Main Runner	Intermediate Duty	144	1.5	0.015	48	12.05	30.13
EZEVS 12-12-15-G90	Main Runner	Intermediate Duty ⁶	144	1.5	0.015	60	5.00	15.63
EZEVS 2-12-12-G90	Cross Tee	—————	24	1.5	0.012	24	36.14	45.18
EZEVS 4-12-12-G90	Cross Tee	—————	48	1.5	0.012	48	8.98	22.44
EZEVS 4-12-20-G90	Cross Tee	—————	48	1.5	0.020	48	16.7	41.72
¹⁵ / ₁₆ " EZ Stab Cleanroom System ²								
EZCRS 12-12-20	Main Runner	Heavy Duty	144	1.5	0.020	48	16.6	41.47
EZCRS 2-12-12	Cross Tee	—————	24	1.5	0.012	24	45.6	57.01
EZCRS 4-12-12	Cross Tee	—————	48	1.5	0.012	48	10.6	26.48
EZCRS 4-12-20	Cross Tee	—————	48	1.5	0.020	48	16.4	41
¹⁵ / ₁₆ " All Aluminum System								
ALC12-16-50	Main Runner	Heavy Duty	144	2.0	0.050	48	17	42.5
ALC2-16-50	Cross Tee	—————	24	2.0	0.050	24	88	110
ALC4-16-50	Cross Tee	—————	48	2.0	0.050	48	17	42.5

TABLE 1—DIMENSIONS AND ALLOWABLE LOADS FOR SUSPENDED CEILING FRAMING MEMBERS⁵ (Continued)

ITEM NUMBER	MEMBER TYPE	LOAD CLASSIFICATION	NOMINAL LENGTH OF MEMBER (inches)	HEIGHT OF MEMBER (inches)	METAL THICKNESS (inch)	MAXIMUM SPAN (inches)	ALLOWABLE UNIFORM LOAD (plf)	ALLOWABLE CONCENTRATED LOAD AT MIDSPAN (lbf) ¹
1 1/2" All Aluminum System								
ALW12-16-50	Main Runner	Heavy Duty	144	2.0	0.050	48	21.5	53.75
ALW2-16-50	Cross Tee	—————	24	2.0	0.050	24	111.5	139.38
ALW4-16-50	Cross Tee	—————	48	2.0	0.050	48	21.5	53.75
1 5/16" All Aluminum Cleanroom System ²								
ALCG12-16-50	Main Runner	Heavy Duty	144	2.0	0.050	48	17	42.5
ALCG2-16-50	Cross Tee	—————	24	2.0	0.050	24	88	110
ALCG4-16-50	Cross Tee	—————	48	2.0	0.050	48	17	42.5
1 1/2" All Aluminum Cleanroom System ²								
ALWG12-16-50	Main Runner	Heavy Duty	144	2.0	0.050	48	21.5	53.75
ALWG2-16-50	Cross Tee	—————	24	2.0	0.050	24	111.5	139.38
ALWG4-16-50	Cross Tee	—————	48	2.0	0.050	48	21.5	53.75
1 5/16" FireSecure Stab Fire Rated System ⁷								
FSS 12-12-15	Main Runner	Intermediate Duty	144	1.5	0.016	48	13.35	33.75
FSS 2-12-15	Cross Tee	—————	24	1.5	0.015	24	44	55.01
FSS 4-12-15	Cross Tee	—————	48	1.5	0.015	48	10.28 ³	25.71
1 5/16" FireSecure EZ Stab ⁷								
FSEZ12-12-15	Main Runner	Intermediate Duty	144	1.5	0.015	48	13.56	33.9
FSEZ12-12-20	Main Runner	Heavy Duty	144	1.5	0.020	48	16.58	41.45
FSEZ2-12-12	Cross Tee	—————	24	1.5	0.012	24	34.8	43.51
FSEZ2-12-20	Cross Tee	—————	24	1.5	0.020	24	50	62.50
FSEZ4-12-12	Cross Tee	—————	48	1.5	0.012	48	9.67	24.16
FSEZ4-12-20	Cross Tee	—————	48	1.5	0.020	48	16.58	41.45
9/16" EZ Stab Bolt Slot 1/4-inch								
4EZB 12-14-17-24	Main Runner	Heavy Duty	144	1.75	0.016	48	16.2	40.5
4EZB 12-14-17-48	Main Runner	Heavy Duty	144	1.75	0.016	48	16.2	40.5
4EZB 10-14-17-20	Main Runner	Heavy Duty	120	1.75	0.016	48	16.2	40.5
4EZB 10-14-17-30	Main Runner	Heavy Duty	120	1.75	0.016	48	16.2	40.5
4EZB 2-14-17-00	Cross Tee	—————	24	1.75	0.016	24	103.0	103.0
4EZB 4-14-17-00	Cross Tee	—————	48	1.75	0.016	48	16.2	40.5
4EZB 4-14-17-224	Cross Tee	—————	48	1.75	0.016	48	16.2	40.5
4EZB 4-14-17-124	Cross Tee	—————	48	1.75	0.016	48	16.2	40.5
4EZB 12-14-15-24	Main Runner	Intermediate Duty	144	1.75	0.014	48	14.2	35.5
4EZB 12-14-15-48	Main Runner	Intermediate Duty	144	1.75	0.014	48	14.2	35.5
4EZB 10-14-15-20	Main Runner	Intermediate Duty	120	1.75	0.014	48	14.2	35.5
4EZB 10-14-15-30	Main Runner	Intermediate Duty	120	1.75	0.014	48	14.2	35.5
4EZB 1.67-14-15-00	Cross Tee	—————	20	1.75	0.014	20	114.4	95.3
4EZB 2-14-15-00	Cross Tee	—————	24	1.75	0.014	24	81.3	81.3
4EZB 2.5-14-15-00	Cross Tee	—————	30	1.75	0.014	30	51.5	64.4
4EZB 4-14-15-224	Cross Tee	—————	48	1.75	0.014	48	14.2	35.5
4EZB 4-14-15-124	Cross Tee	—————	48	1.75	0.014	48	14.2	35.5
4EZB 4-14-15-00	Cross Tee	—————	48	1.75	0.014	48	14.2	35.5
4EZB 5-14-15-00	Cross Tee	—————	60	1.75	0.014	60	7.5	23.4
4EZB 5-14-15-230	Cross Tee	—————	60	1.75	0.014	60	7.5	23.4
4EZB 5-14-15-220	Cross Tee	—————	60	1.75	0.014	60	7.5	23.4
4EZB 5-14-15-120	Cross Tee	—————	60	1.75	0.014	60	7.5	23.4
9/16" EZ Stab Bolt Slot 1/8-inch								
8EZB 12-14-17-24	Main Runner	Heavy Duty	144	1.75	0.016	48	16.1	40.2
8EZB 12-14-17-48	Main Runner	Heavy Duty	144	1.75	0.016	48	16.1	40.2
8EZB 10-14-17-20	Main Runner	Heavy Duty	120	1.75	0.016	48	16.1	40.2
8EZB 10-14-17-30	Main Runner	Heavy Duty	120	1.75	0.016	48	16.1	40.2

TABLE 1—DIMENSIONS AND ALLOWABLE LOADS FOR SUSPENDED CEILING FRAMING MEMBERS⁵ (Continued)

ITEM NUMBER	MEMBER TYPE	LOAD CLASSIFICATION	NOMINAL LENGTH OF MEMBER (inches)	HEIGHT OF MEMBER (inches)	METAL THICKNESS (inch)	MAXIMUM SPAN (inches)	ALLOWABLE UNIFORM LOAD (plf)	ALLOWABLE CONCENTRATED LOAD AT MIDSPAN (lbf) ¹
8EZB 2-14-17-00	Cross Tee	—————	24	1.75	0.016	24	96.8	96.8
8EZB 4-14-17-00	Cross Tee	—————	48	1.75	0.016	48	16.1	40.2
8EZB 4-14-17-224	Cross Tee	—————	48	1.75	0.016	48	16.1	40.2
8EZB 4-14-17-124	Cross Tee	—————	48	1.75	0.016	48	16.1	40.2
8EZB 12-14-15-24	Main Runner	Intermediate Duty	144	1.75	0.014	48	13.0	32.5
8EZB 12-14-15-48	Main Runner	Intermediate Duty	144	1.75	0.014	48	13.0	32.5
8EZB 10-14-15-20	Main Runner	Intermediate Duty	120	1.75	0.014	48	13.0	32.5
8EZB 10-14-15-30	Main Runner	Intermediate Duty	120	1.75	0.014	48	13.0	32.5
8EZB 1.67-14-15-00	Cross Tee	—————	20	1.75	0.014	20	115.8	96.5
8EZB 2-14-15-00	Cross Tee	—————	24	1.75	0.014	24	74.7	74.7
8EZB 2.5-14-15-00	Cross Tee	—————	30	1.75	0.014	30	48.9	61.1
8EZB 4-14-15-00	Cross Tee	—————	48	1.75	0.014	48	13.0	32.5
8EZB 4-14-15-224	Cross Tee	—————	48	1.75	0.014	48	13.0	32.5
8EZB 4-14-15-124	Cross Tee	—————	48	1.75	0.014	48	13.0	32.5
8EZB 5-14-15-00	Cross Tee	—————	60	1.75	0.014	60	7.6	23.8
8EZB 5-14-15-230	Cross Tee	—————	60	1.75	0.014	60	7.6	23.8
8EZB 5-14-15-220	Cross Tee	—————	60	1.75	0.014	60	7.6	23.8
8EZB 5-14-15-120	Cross Tee	—————	60	1.75	0.014	60	7.6	23.8
8EZB 6-14-15-224	Cross Tee	—————	144	1.80	0.015	72	4.8 ³	18
8EZB 6-14-17-224	Cross Tee	—————	144	1.80	0.017	96	5.5 ³	27.5
8EZB 8-14-15-224	Cross Tee	—————	144	1.80	0.015	72	2.1 ³	7.9
8EZB 8-14-17-224	Cross Tee	—————	144	1.80	0.017	96	2.5 ³	12.5
9/16" EZ Stab Tier Drop								
EZTD 12-14-18	Main Runner	Heavy Duty	144	1.75	0.017	48	16.5	41.2
EZTD 2-14-18	Cross Tee	—————	24	1.75	0.017	24	75.8	75.8
EZTD 4-14-18	Cross Tee	—————	48	1.75	0.017	48	16.5	41.2
EZTD 12-14-15	Main Runner	Intermediate Duty	144	1.75	0.015	48	15.0	37.5
EZTD 2-14-15	Cross Tee	—————	24	1.75	0.015	24	55.8	55.8
EZTD 2.5-14-15	Cross Tee	—————	30	1.75	0.015	30	42.0	52.5
EZTD 4-14-15	Cross Tee	—————	48	1.75	0.015	48	15.0	37.5
EZTD 5-14-15	Cross Tee	—————	60	1.75	0.015	60	7.8	24.4
EZTD 5-14-15-3S	Cross Tee	—————	60	1.75	0.015	60	7.8	24.4
EZTD 6-14-15	Cross Tee	—————	72	1.75	0.015	72	4.6	17.2
EZTD 8-14-15	Cross Tee	—————	96	1.75	0.015	96	2.0	10.0
1 1/2" EZ Drywall Grid System ⁴								
EZDWS 3600MM-13-18	Main Runner	Heavy Duty	141.73	1.6	0.017	48	19.21	48.03
EZDWS 12-13-18	Main Runner	Heavy Duty	144	1.6	0.016	48	19.2	48.0
EZDWS 1.16-13-18	Cross Tee	—————	14	1.6	0.017	14	253.62	184.93
EZDWS 600MM-13-18	Cross Tee	—————	23.62	1.6	0.017	23.62	77.88	95.81
EZDWS 2-13-18	Cross Tee	—————	24	1.6	0.017	24	76.00	95.03
EZDWS 2.16-13-18	Cross Tee	—————	26	1.6	0.017	26	67.90	91.98
EZDWS 750MM-13-18	Cross Tee	—————	29.53	1.6	0.017	29.53	55.82	85.85
EZDWS 900MM-13-18	Cross Tee	—————	35.43	1.6	0.017	35.43	43.43	80.14
EZDWS 3-13-18	Cross Tee	—————	36	1.6	0.017	36	42.50 ³	79.71
EZDWS 1200MM-13-18	Cross Tee	—————	47.24	1.6	0.017	47.24	20.08	49.41
EZDWS 4-13-18	Cross Tee	—————	48	1.6	0.017	48	18.32 ³	45.8
EZDWS 4.16-13-18	Cross Tee	—————	50	1.6	0.017	50	16.6 ³	43.35
EZDWS 1500M-13-18	Cross Tee	—————	59.06	1.6	0.017	59.06	10.31	31.71
EZDWS 5-13-18	Cross Tee	—————	60	1.6	0.017	60	9.86	30.81
EZDWS 6-13-18	Cross Tee	—————	72	1.6	0.017	72	5.89 ³	22.09

TABLE 1—DIMENSIONS AND ALLOWABLE LOADS FOR SUSPENDED CEILING FRAMING MEMBERS⁵ (Continued)

ITEM NUMBER	MEMBER TYPE	LOAD CLASSIFICATION	NOMINAL LENGTH OF MEMBER (inches)	HEIGHT OF MEMBER (inches)	METAL THICKNESS (inch)	MAXIMUM SPAN (inches)	ALLOWABLE UNIFORM LOAD (plf)	ALLOWABLE CONCENTRATED LOAD AT MIDSPAN (lbf) ¹
1 1/2" Drywall Grid System ⁴								
DWS 3600MM-13-20	Main Runner	Heavy Duty	141.73	1.6	0.017	48	19.21	48.03
DWS 12-13-20	Main Runner	Heavy Duty	144	1.6	0.016	48	19.2	48.0
DWS 1.16-13-20	Cross Tee	—————	14	1.6	0.017	14	253.62	184.93
ITEM NUMBER	MEMBER TYPE	LOAD CLASSIFICATION	NOMINAL LENGTH OF MEMBER (inches)	HEIGHT OF MEMBER (inches)	METAL THICKNESS (inch)	MAXIMUM SPAN (inches)	ALLOWABLE UNIFORM LOAD (plf)	ALLOWABLE CONCENTRATED LOAD AT MIDSPAN (lbf) ¹
DWS 600MM-13-20	Cross Tee	—————	23.62	1.6	0.017	23.62	77.88	95.81
DWS 2-13-20	Cross Tee	—————	24	1.6	0.017	24	76.00	95.03
DWS 2.16-13-20	Cross Tee	—————	26	1.6	0.017	26	67.90	91.98
DWS 750MM-13-20	Cross Tee	—————	29.53	1.6	0.017	29.53	55.82	85.85
DWS 900MM-13-20	Cross Tee	—————	35.43	1.6	0.017	35.43	43.43	80.14
DWS 3-13-20	Cross Tee	—————	36	1.6	0.017	36	42.50 ³	79.71
DWS 1200MM-13-20	Cross Tee	—————	47.24	1.6	0.017	47.24	20.08	49.41
DWS 4-13-20	Cross Tee	—————	48	1.6	0.017	48	18.32 ³	45.8
DWS 4.16-13-20	Cross Tee	—————	50	1.6	0.017	50	16.6 ³	43.35
DWS 1500MM-13-20	Cross Tee	—————	59.06	1.6	0.017	59.06	10.31	31.71
DWS 5-13-20	Cross Tee	—————	60	1.6	0.017	60	9.86	30.81
DWS 6-13-20	Cross Tee	—————	72	1.6	0.017	72	5.89 ³	22.09

For SI: 1 inch=25.4 mm; 1 lbf = 4.45 N, 1 plf = 14.6 N/m.

¹Allowable concentrated loads at midspan are determined in accordance with AC308 Section 3.2. For each framing member, the allowable concentrated load must not be combined with the allowable uniform load.

²The 15/16" EZ Stab Classic Environmental System with a G60 hot-dipped galvanized coating. The 15/16" EZ Stab Cleanroom System has a G60 hot-dipped galvanized coating and includes a gasket tape on the interior flange side. The 15/16" All Aluminum Cleanroom System and 1 1/2" All Aluminum Cleanroom System include a gasket affixed to the top surfaces of the flanges.

³Laterally braced at mid-span.

⁴All "DWS" items above are available in G90 hot dipped galvanized coating and identified with the item number ending in G90.

⁵DWS Series main runners may be used with EZDWS cross tees; and EZDWS main runners may be used with DWS cross tees. When Drywall Series (DWS) cross tee clips do not match with EZ Series cross tee clips through main runner slots, two L-brackets (CertainTeed item LBRC) must be fastened on each side of the main runner and cross tee (one L-bracket on each side of the connection) using a minimum of two (2) #7 x 7/16 inch steel screws per bracket in order to achieve AC308 connection requirements.

⁶ Heavy duty and Intermediate duty ratings for main runners are based on main runner capacity at 4 foot span.

⁷ All 15/16" FireSecure Stab Fire Rated System and 15/16" FireSecure EZ Stab main runners must be installed in accordance with ASTM C636 with respect to the location of vertical support hanger wires; hanger wires are required on both sides of the fire break and as shown in Figure 16.

TABLE 2—CEILING LOAD LIMITS (PSF) FOR DIFFERENT CONFIGURATIONS OF DRYWALL SYSTEMS (DWS/EZDWS) AT L/360 WITH CROSS TEES AT 24 INCHES ON CENTER

		Hanger Spacing on Main Runner (inches) ¹		
		48	32	16
Main Runner Spacing (inches on center)	72	2.9	2.9	2.9
	50	4.5	8.3	8.3
	48	4.7	9.2	9.2
	36	6.2	10	10
	24	9.3	10	10

For SI: 1 inch=25.4 mm; 1 psf= 574.6 Pa.

¹Hanger wires must comply with Section 3.3.2 of this report.

TABLE 3—CEILING LOAD LIMITS (PSF) FOR DIFFERENT CONFIGURATIONS OF DRYWALL SYSTEMS (DWS/EZDWS) AT L/240 WITH CROSS TEES AT 24 INCHES ON CENTER

		Hanger Spacing on Main Runner (inches) ¹		
		48	32	16
Main Runner Spacing (inches on center)	72	3.8	4.4	4.4
	50	5.5	10	10
	48	5.7	10	10
	36	7.6	10	10
	24	10	10	10

For SI: 1 inch=25.4 mm; 1 psf= 574.6 Pa.

¹Hanger wires must comply with Section 3.3.2 of this report.

TABLE 4—CEILING LOAD LIMITS (PSF) FOR DIFFERENT CONFIGURATIONS OF DRYWALL SYSTEMS (DWS/EZDWS) AT L/360 WITH CROSS TEES AT 16 INCHES ON CENTER

		Hanger Spacing on Main Runner (inches) ¹		
		48	32	16
Main Runner Spacing (inches on center)	72	3.1	4.4	4.4
	50	4.5	10	10
	48	4.7	10	10
	36	6.2	10	10
	24	9.3	10	10

For **SI**: 1 inch=25.4 mm; 1 psf= 574.6 Pa.

¹Hanger wires must comply with Section 3.3.2 of this report.

TABLE 5—CEILING LOAD LIMITS (PSF) FOR DIFFERENT CONFIGURATIONS OF DRYWALL SYSTEMS (DWS/EZDWS) AT L/240 WITH CROSS TEES AT 16 INCHES ON CENTER

		Hanger Spacing on Main Runner (inches) ¹		
		48	32	16
Main Runner Spacing (inches on center)	72	4.7	6.5	6.5
	50	6.7	10	10
	48	7.0	10	10
	36	9.3	10	10
	24	10	10	10

For **SI**: 1 inch=25.4 mm; 1 psf= 574.6 Pa.

¹Hanger wires must comply with Section 3.3.2 of this report.

**9/16" EZ Stab Elite HD
Grid Profile (EZES)**

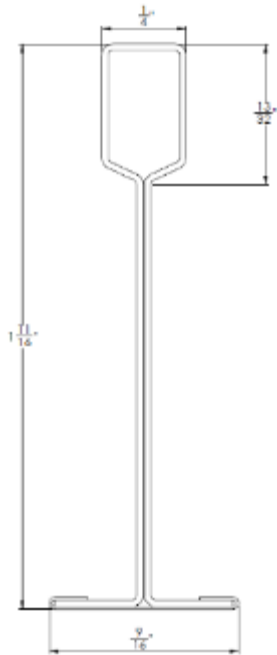

**9/16" EZ Stab Elite ID
Grid Profile (EZES)**

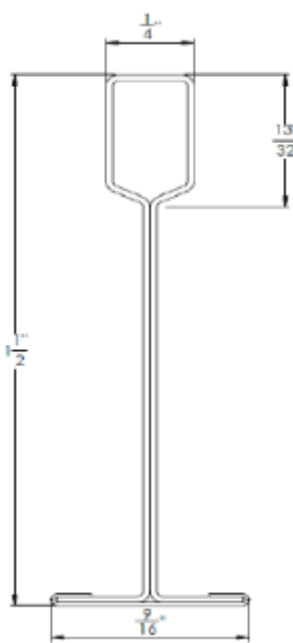

**15/16" EZ Stab Classic
Grid Profile (EZCS, FSEZ)**

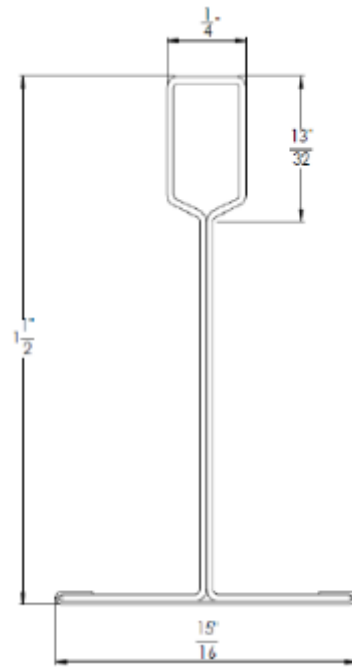

**Drywall Grid Profile
(EZDWS/DWS)**

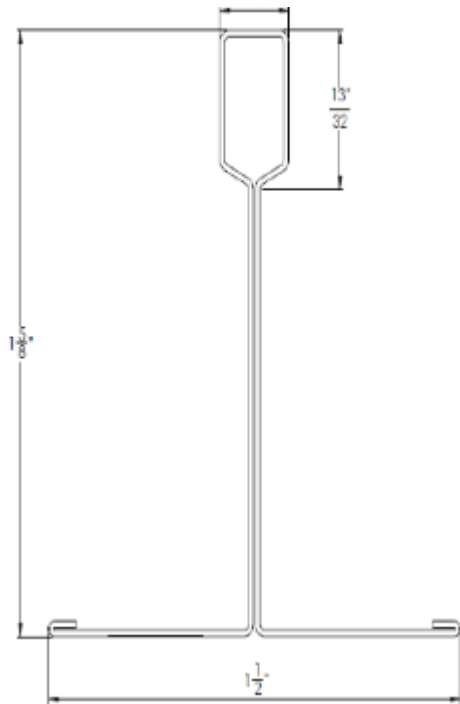

**FireSecure Grid
Profile (FSS)**

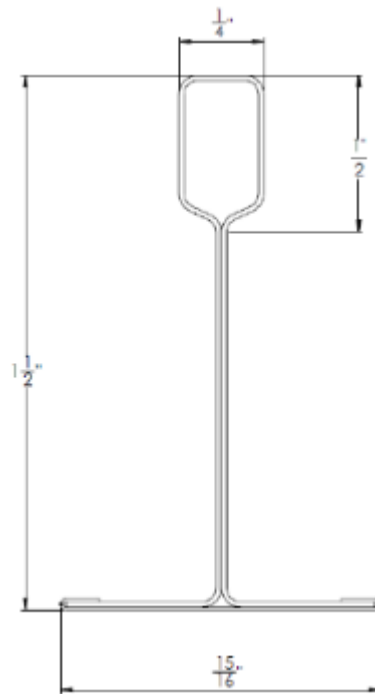
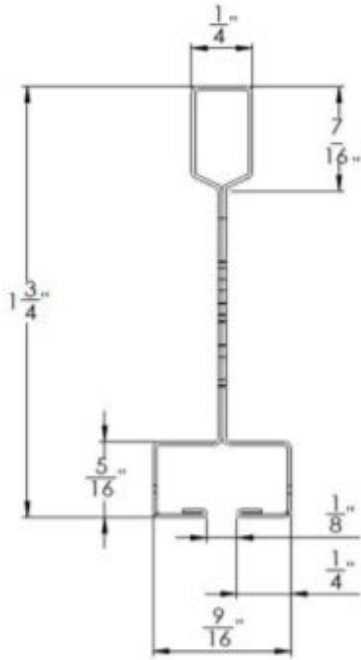
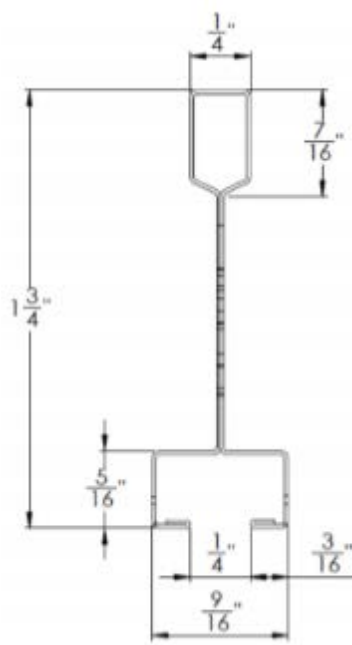

FIGURE 1—FRAMING MEMBER PROFILES

**9/16" Bolt Slot Grid
Profile 1/8" (8EZB)**



**9/16" Bolt Slot Grid
Profile 1/4" (4EZB)**



**Tier Drop Grid
Profile (EZTD)**

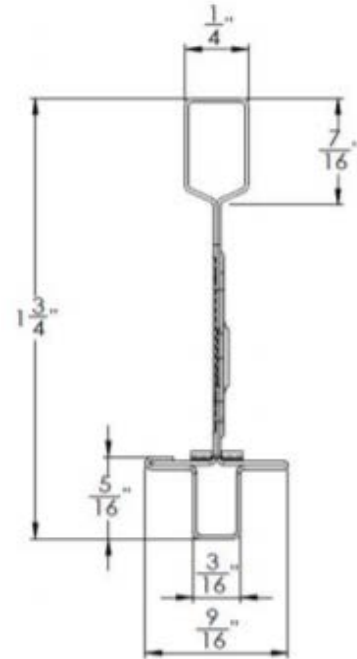

**1-1/2" All Aluminum System
(ALW/ALWG)**

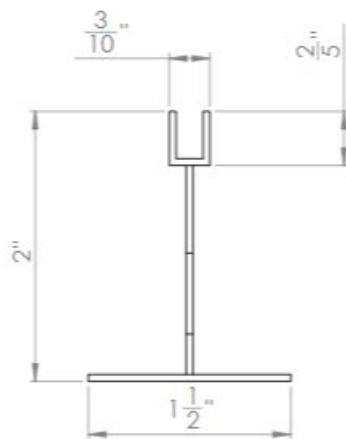

**15/16" All Aluminum System
(ALC/ALCG)**

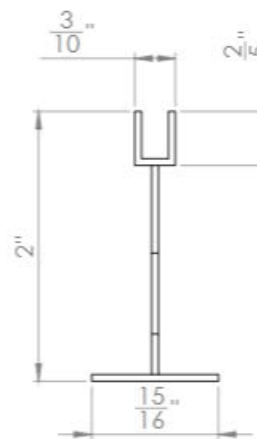
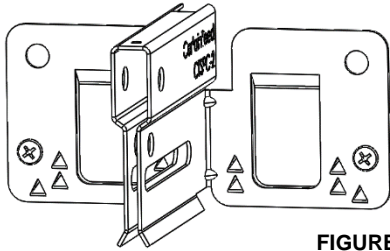

FIGURE 1—FRAMING MEMBER PROFILES (continued)

**CertainTeed Seismic
Perimeter Clip (CTSPC-2:
EZCS, FSEZ & EZES screw
attachment at 4 PSF)**



**CertainTeed Seismic
Perimeter Clip 2
(CTSPC-2)**

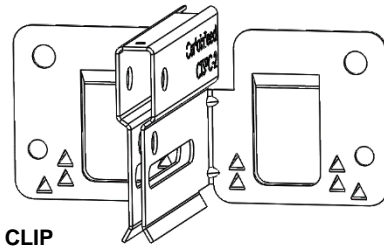

FIGURE 2 – SEISMIC PERIMETER CLIP

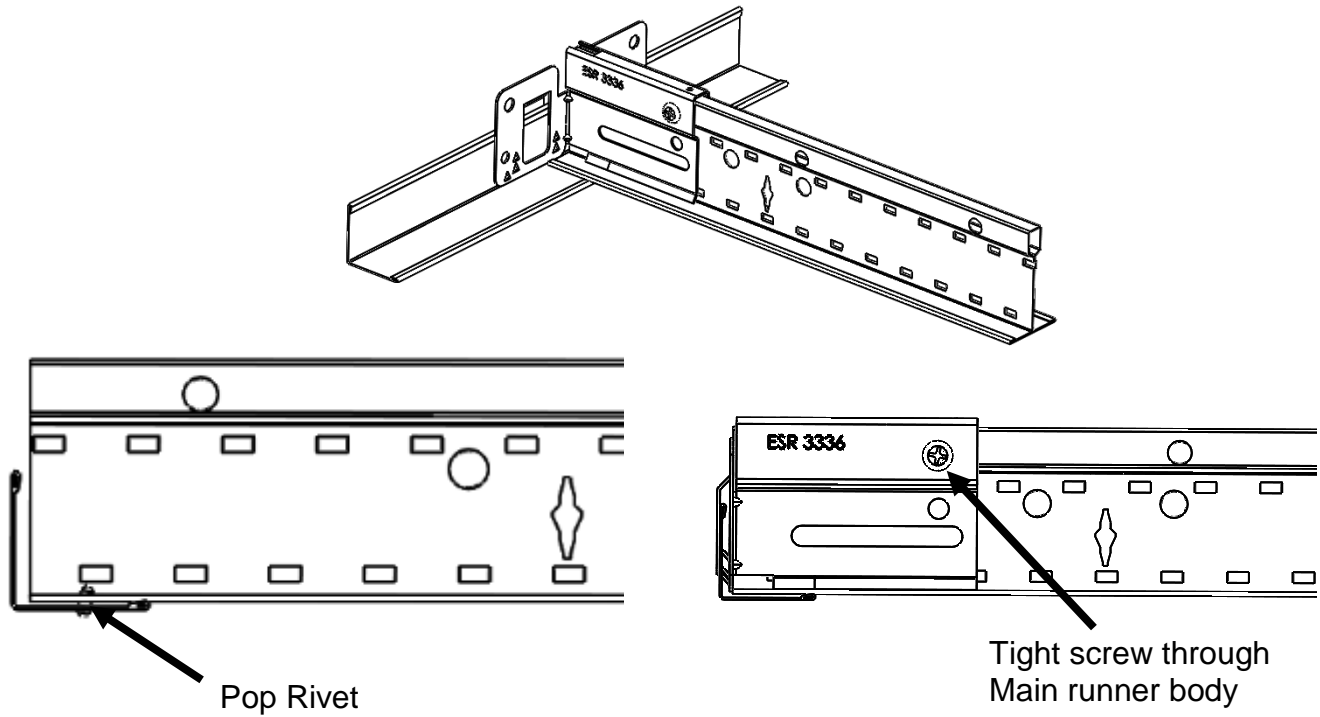

FIGURE 3A – SEISMIC PERIMETER CLIP FIXED WALL ASSEMBLY IN SECTION 4.2.1

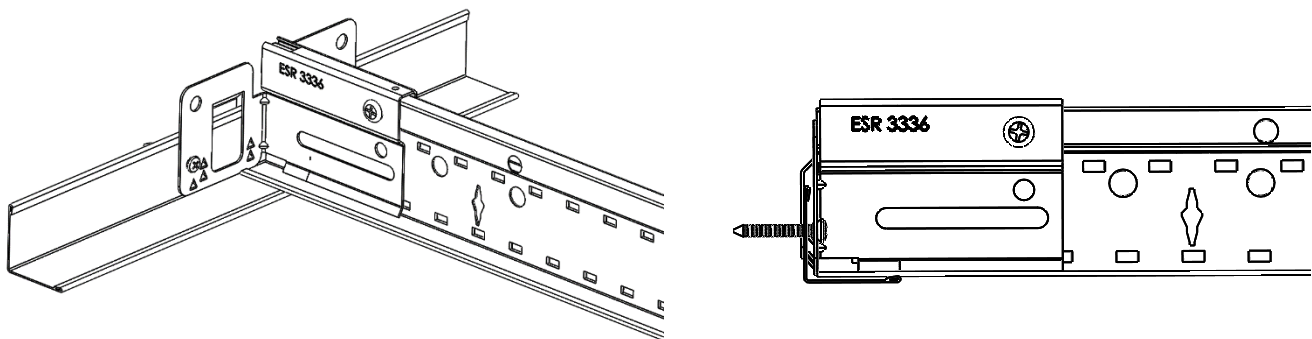

FIGURE 3B – SEISMIC PERIMETER CLIP (CTSPC-2 WITH TWO SCREW ATTACHMENT)
FIXED WALL ASSEMBLY WITH WALL ANGLE (WA14-14 OR WA15-15) IN SECTION 4.2.2

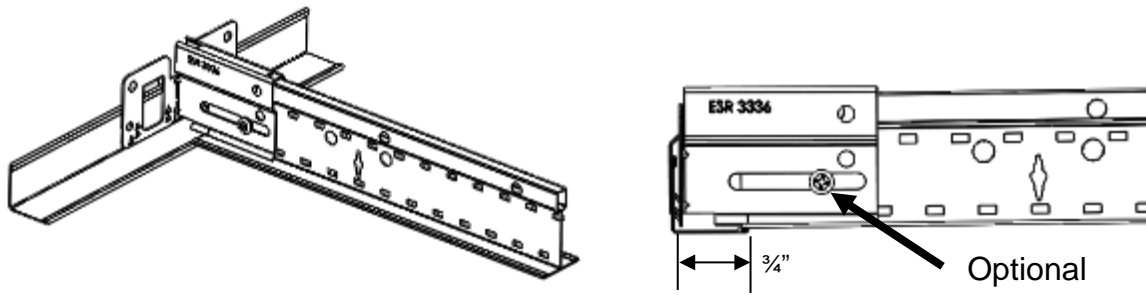

FIGURE 4A – SEISMIC PERIMETER CLIP FREE WALL ASSEMBLY IN SECTION 4.2.1

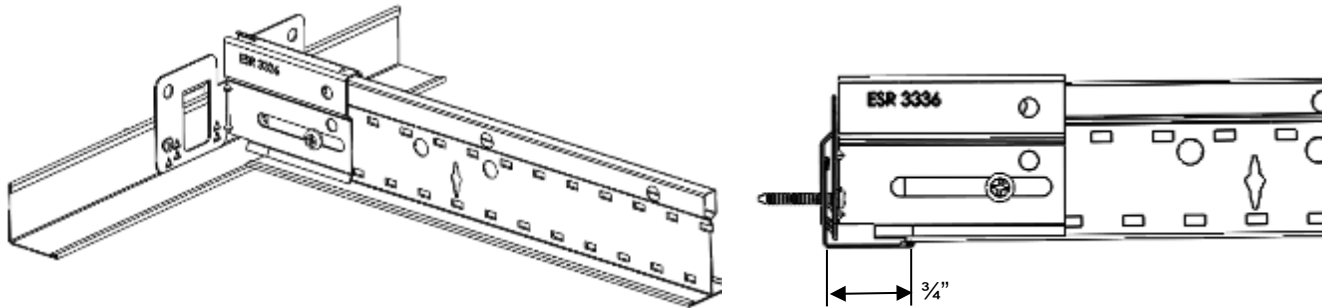

FIGURE 4B – SEISMIC PERIMETER CLIP (CTSPC-2 WITH TWO SCREW ATTACHMENT) FREE WALL ASSEMBLY WITH WALL ANGLE (WA14-14 OR WA15-15) IN SECTION 4.2.2

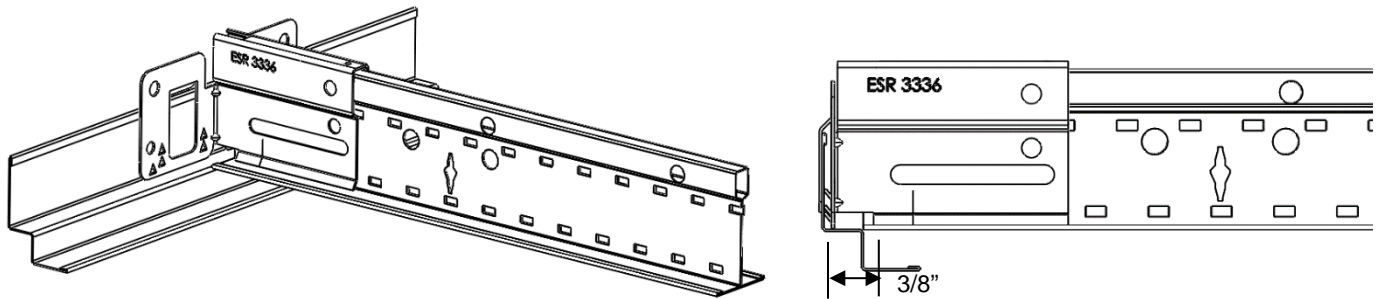

FIGURE 5 – SEISMIC PERIMETER CLIP FREE WALL SETUP FOR SEISMIC DESIGN CATEGORY C IN SECTION 4.2.4 (SHADOW MOLDING SM1020)

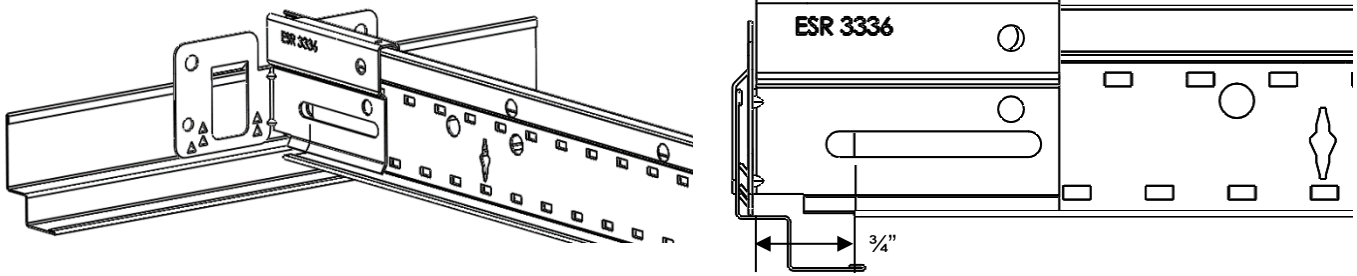

FIGURE 6A – SEISMIC PERIMETER CLIP FREE WALL SETUP FOR SEISMIC DESIGN CATEGORIES D, E, AND F IN SECTION 4.2.1 (SHADOW MOLDING SM1000)

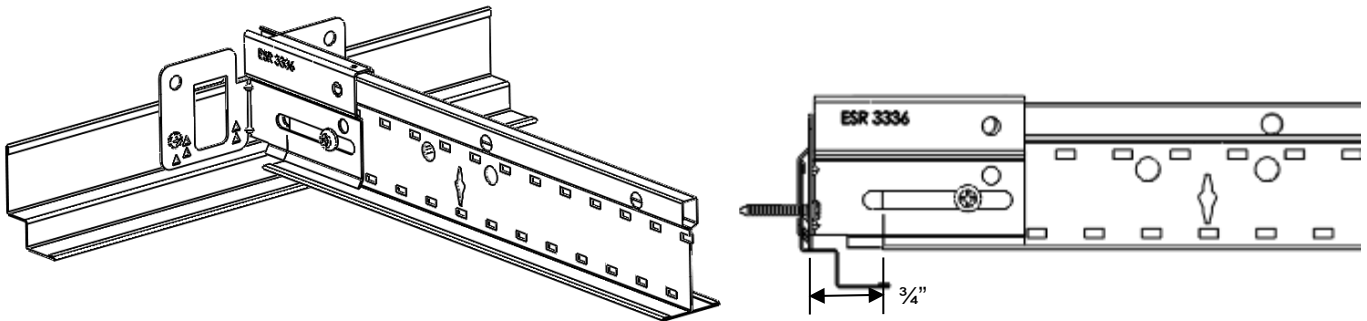

FIGURE 6B – SEISMIC PERIMETER CLIP (CTSPC-2 WITH TWO SCREW ATTACHMENT) FREE WALL SETUP FOR SEISMIC DESIGN CATEGORIES D, E, AND F IN SECTION 4.2.2 (SHADOW MOLDING SM1040 OR SM1050)

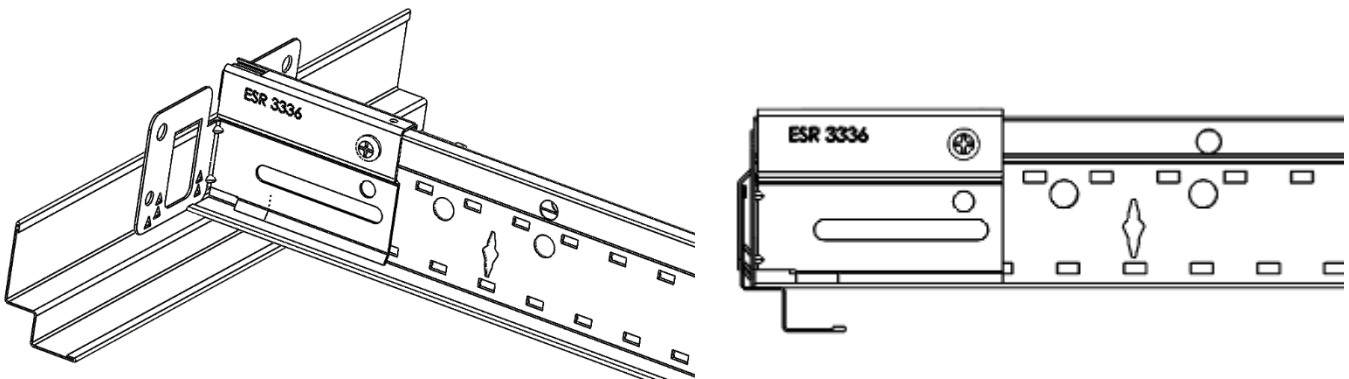

FIGURE 7A – SEISMIC PERIMETER CLIP FIXED WALL SETUP FOR SEISMIC DESIGN CATEGORIES D, E, AND F IN SECTION 4.2.1 (SHADOW MOLDING SM1000)

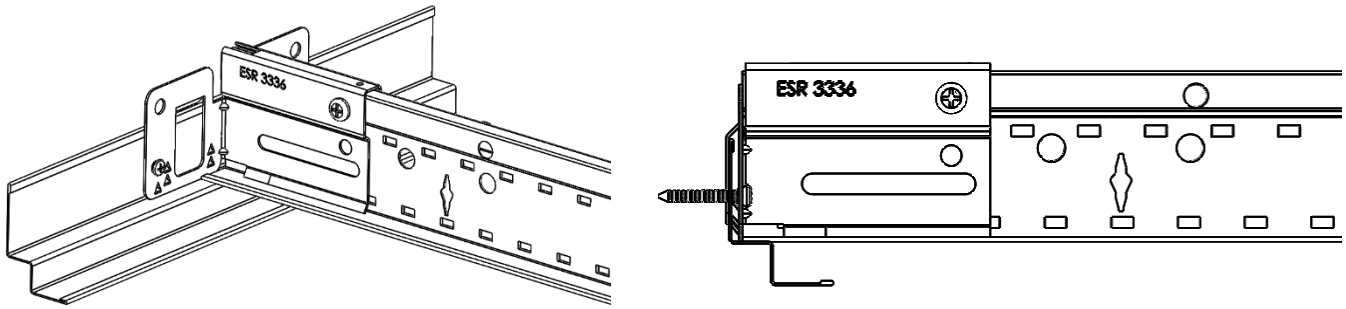

FIGURE 7B – SEISMIC PERIMETER CLIP (CTSPC-2 WITH TWO SCREW ATTACHMENT) FREE WALL SETUP FOR SEISMIC DESIGN CATEGORIES D, E, AND F IN SECTION 4.2.2 (SHADOW MOLDING SM1040 OR SM1050)

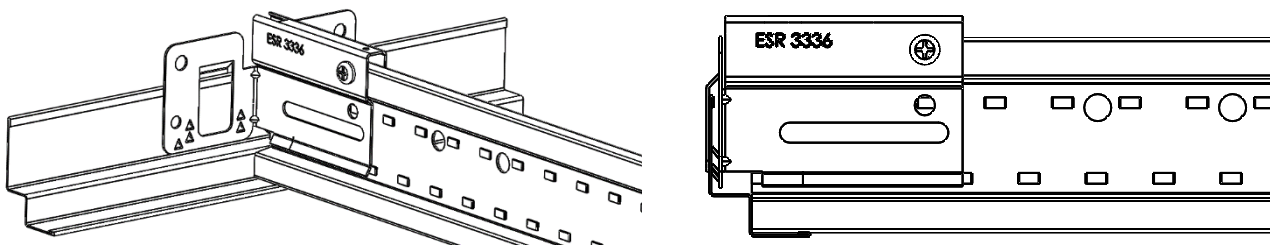

FIGURE 8 – 9/16" EZ STAB BOLT SLOTS AND 9/16" EZ STAB TIER DROP FIXED WALL SETUP WITH SHADOW MOLD (SM1020, SM1040 OR SM1050) AND SEISMIC PERIMETER CLIP (SEISMIC DESIGN CATEGORIES A, B, C, D, E, AND F) IN SECTION 4.2.3 AND 4.2.5

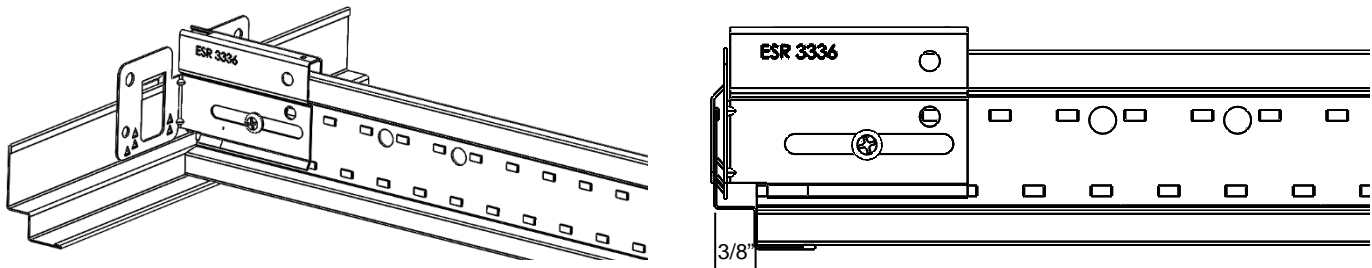

FIGURE 9 – 9/16" EZ STAB BOLT SLOTS AND 9/16" TIER DROP FREE WALL SETUP (LOOSELY SCREWED) WITH SHADOW MOLD (SM1040 OR SM1050) AND SEISMIC PERIMETER CLIP (SDC A, B, AND C) IN SECTION 4.2.5

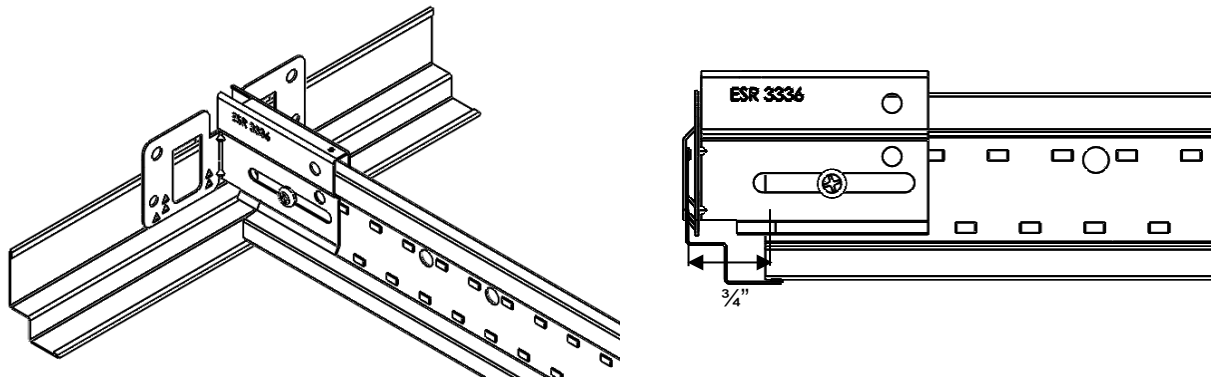

FIGURE 10— $\frac{9}{16}$ " EZ STAB BOLT SLOTS AND $\frac{9}{16}$ " EZ STAB TIER DROP FREE WALL SETUP (LOOSELY SCREWED) WITH SHADOW MOLD (SM1020, SM1040 OR SM1050) AND SEISMIC PERIMETER CLIP (SEISMIC DESIGN CATEGORIES D, E AND F) IN SECTION 4.2.3

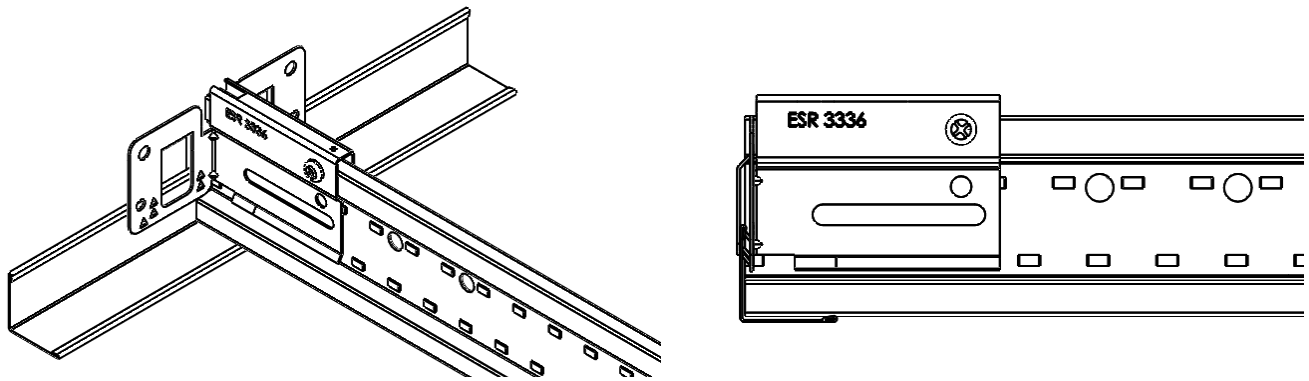

FIGURE 11— $\frac{9}{16}$ " EZ STAB BOLT SLOTS AND $\frac{9}{16}$ " EZ STAB TIER DROP FIXED WALL SETUP WITH WALL ANGLE (WA14-14 OR WA15-15) AND SEISMIC PERIMETER CLIP (SEISMIC DESIGN CATEGORIES A, B, C, D, E AND F) IN SECTIONS 4.2.3 AND 4.2.5

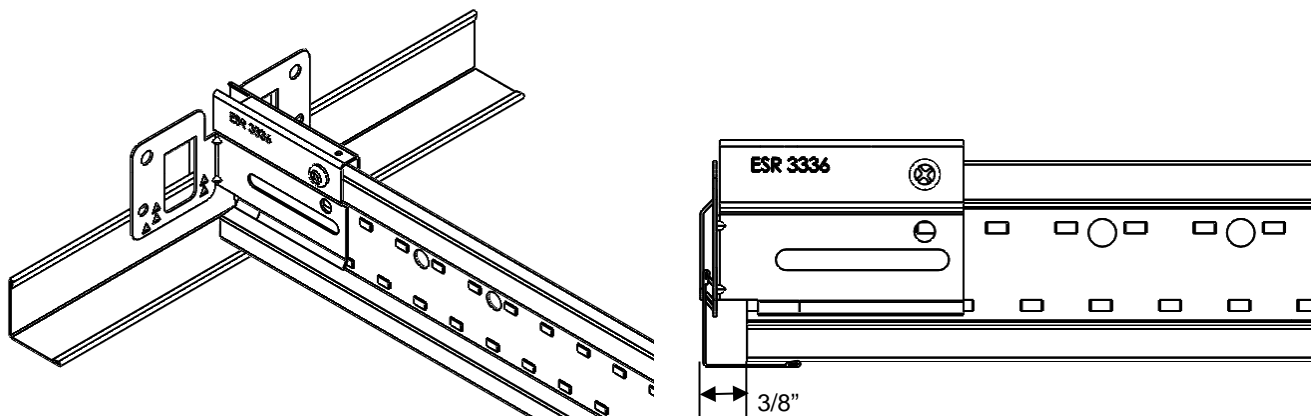

FIGURE 12— $\frac{9}{16}$ " EZ STAB BOLT SLOTS AND $\frac{9}{16}$ " EZ STAB TIER DROP FREE WALL SETUP (LOOSELY SCREWED) WITH WALL ANGLE (WA14-14 OR WA15-15) AND SEISMIC PERIMETER CLIP (SDCS A, B AND C) IN SECTION 4.2.5

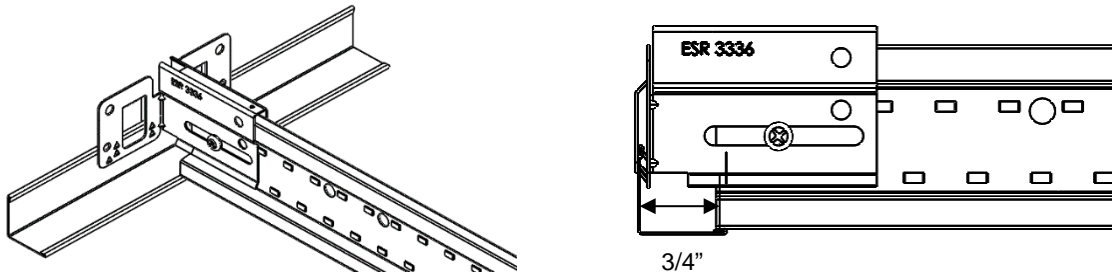
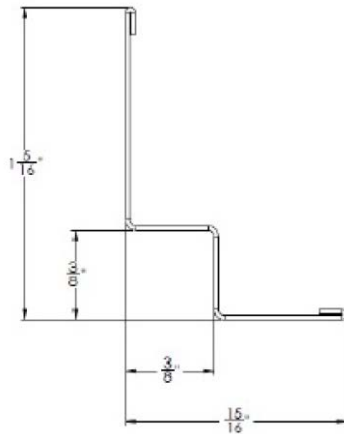
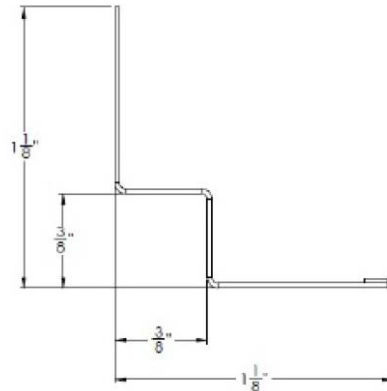

FIGURE 13— $\frac{9}{16}$ " EZ STAB BOLT SLOTS AND $\frac{9}{16}$ " EZ STAB TIER DROP FREE WALL SETUP (LOOSELY SCREWED) WITH WALL ANGLE (WA14-14 OR WA15-15) AND SEISMIC PERIMETER CLIP (SDCS D, E AND F) IN SECTION 4.2.3



FRONT VIEW
SCALE:1/8"

SM1000



FRONT VIEW
SCALE:1/8"

SM1020

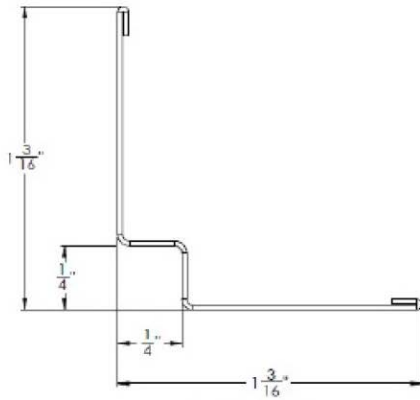

FRONT VIEW
SCALE:1/8"

SM1040

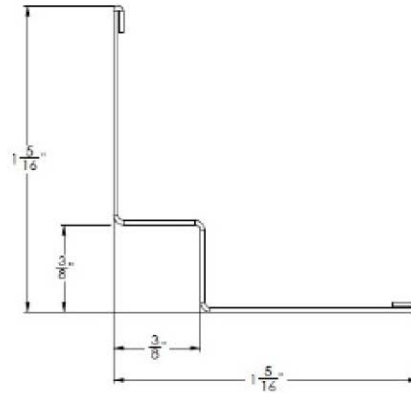

FRONT VIEW
SCALE:1/8"

SM1050

FIGURE 14—SHADOW MOLDINGS AND WALL ANGLE

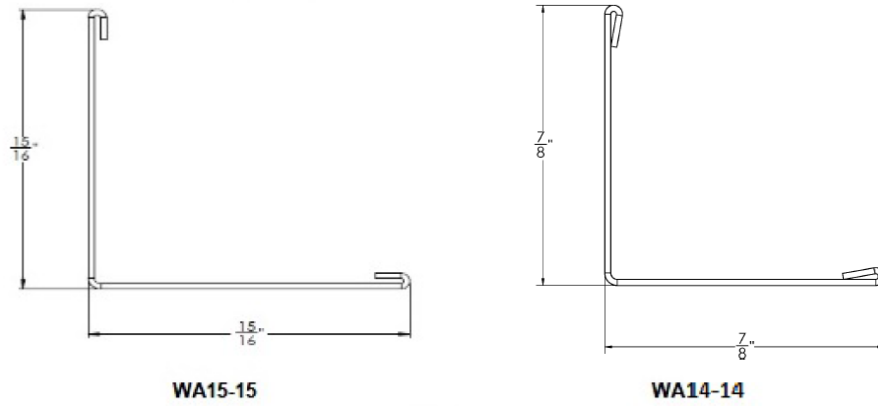

FIGURE 14—SHADOW MOLDINGS AND WALL ANGLE (CONTINUED)

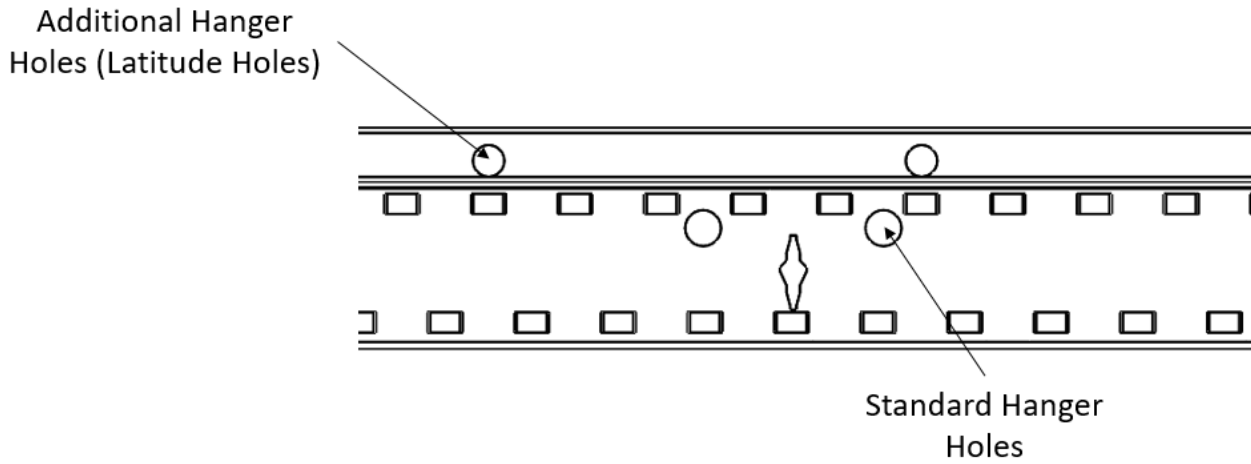

FIGURE 15—EZ HANGER HOLE LOCATIONS

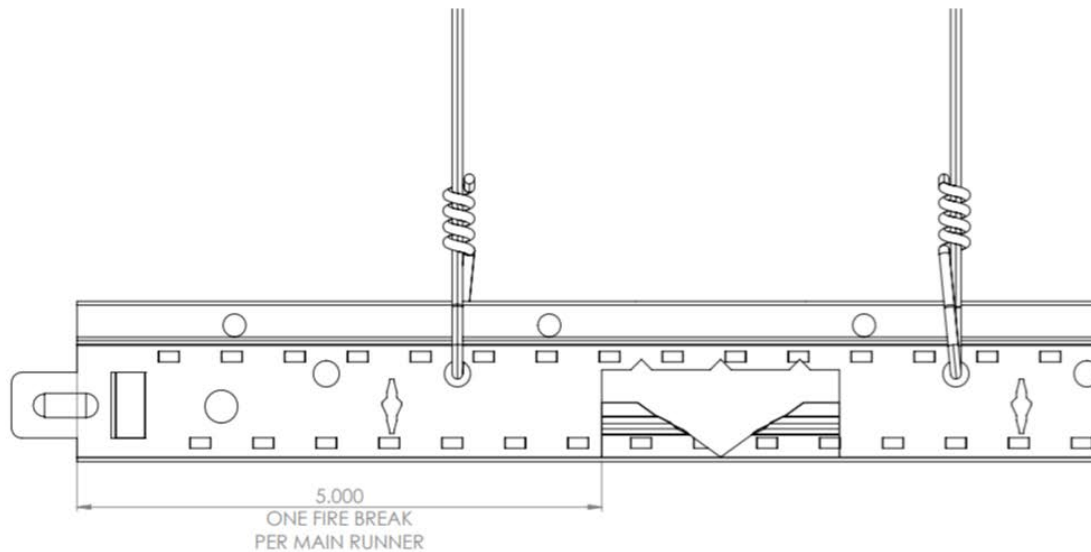

FIGURE 16—FIRE ASSEMBLY HANGER WIRE LOCATIONS

DIVISION: 09 00 00—FINISHES
Section: 09 22 26—Suspension Systems
Section: 09 53 00—Acoustical Ceiling Suspension Assemblies

REPORT HOLDER:

CERTAINTEED CEILINGS CORPORATION

EVALUATION SUBJECT:

SUSPENDED CEILING FRAMING SYSTEMS AND SEISMIC PERIMETER CLIP

1.0 REPORT PURPOSE AND SCOPE

Purpose:

The purpose of this evaluation report supplement is to indicate that the CertainTeed suspended ceiling framing systems and seismic perimeter clip, described in ICC-ES evaluation report [ESR-3336](#), have also been evaluated for compliance with the code noted below as adopted by the Los Angeles Department of Building and Safety (LADBS).

Applicable code edition:

2020 *City of Los Angeles Building Code* (LABC)

2.0 CONCLUSIONS

The CertainTeed suspended ceiling framing systems and seismic perimeter clip, described in Sections 2.0 through 7.0 of the evaluation report [ESR-3336](#), comply with the LABC Chapters 8, 16 and 25, and are subjected to the conditions of use described in this supplement.

3.0 CONDITIONS OF USE

The CertainTeed suspended ceiling framing systems and seismic perimeter clip described in this evaluation report supplement must comply with all of the following conditions:

- All applicable sections in the evaluation report [ESR-3336](#).
- The design, installation, conditions of use and identification of the CertainTeed suspended ceiling framing systems and seismic perimeter clip are in accordance with the 2018 *International Building Code*® (IBC) provisions noted in the evaluation report [ESR-3336](#).
- The design, installation and inspection are in accordance with additional requirements of LABC Chapters 16 and 17, as applicable.
- Main runners shall be identified by indentation or by nontransferable decal with letters not less than 1/4-inch high, and shall include the company name, runner designation and load rating.

This supplement expires concurrently with the evaluation report, reissued January 2023.

DIVISION: 09 00 00—FINISHES**Section: 09 22 26—Suspension Systems****Section: 09 53 00—Acoustical Ceiling Suspension Assemblies****REPORT HOLDER:****CERTAINTED CEILINGS CORPORATION****EVALUATION SUBJECT:****SUSPENDED CEILING FRAMING SYSTEMS AND SEISMIC PERIMETER CLIP****1.0 EVALUATION SCOPE****Compliance with the following code:**2019 *California Building Code* (CBC)

For evaluation of applicable chapters adopted by the California Office of Statewide Health Planning and Development (OSHPD) AKA: California Department of Health Care Access and Information (HCAI) and the Division of State Architect (DSA), see Sections 2.1 and 2.2 below.

2.0 CONCLUSIONS

The Suspended Ceiling Framing Systems and Seismic Perimeter Clip, described in Sections 2.0 through 7.0 of the evaluation report ESR-3336, comply with CBC Chapters 8, 16 and 25, provided the design and installation are in accordance with the 2018 *International Building Code* (IBC) provisions, as applicable, noted in the evaluation report, and the additional requirements of CBC Chapters 8, 16, 17 and 25, as applicable.

2.1 OSHPD:

The Suspended Ceiling Framing Systems and Seismic Perimeter Clip, described in Section 2.0 through 7.0 of the evaluation report ESR-3336, comply with CBC Chapters 8, 16, 17 and 25, with applicable amendments, and Chapters 16A and 17A, provided the design and installation are in accordance with the 2018 *International Building Code* (IBC) provisions noted in the evaluation report, and the additional requirements in Sections 2.1.1 through 2.1.2 of this supplement:

2.1.1 Conditions of Use:

1. All loads applied shall be determined by a registered structural engineer and shall comply with applicable loads from CBC Chapter 16 and its amendments, and Chapter 16A.
2. Section 13.5.6.2 of ASCE 7 shall be revised in accordance with CBC Section 1617A.1.21 [OSHPD 1 & 4].
3. Design and installation shall comply with the requirements of OSHPD Preapproved Details (OPD) OPD-0002-13 and OPD-0003-13, as applicable.

2.1.2 Special Inspection Requirements:

1. Periodic special inspection is required, in accordance with Section 1705A.12.5 of the CBC [OSHPD 1 & 4].
2. Where gypsum wallboard is used in suspended ceiling installations, additional inspection shall be in accordance with CBC Section 2503.2 [OSHPD 1, 1R, 2, 4 & 5].

2.2 DSA:

The Suspended Ceiling Framing Systems and Seismic Perimeter Clip, described in Section 2.0 through 7.0 of the evaluation report ESR-3336, comply with CBC Chapters 8, 16, 17 and 25, with applicable amendments, and Chapters 16A and 17A, provided the design and installation are in accordance with the 2018 *International Building Code* (IBC) provisions noted in the evaluation report, and the additional requirements in Sections 2.2.1 through 2.2.2 of this supplement:

2.2.1 Conditions of Use:

1. All loads applied shall be determined by a registered structural engineer and shall comply with applicable loads from CBC Chapter 16 and its amendments, and Chapter 16A.
2. Section 13.5.6.2 of ASCE 7 shall be revised in accordance with CBC Section 1617.11.16 [DSA-SS/CC] and Section 1617A.1.21 [DSA-SS].
3. Design and installation shall comply with the requirements of DSA Interpretation of Regulations (IR) DSA IR 25-2.13 and DSA IR 25-3.13 as applicable.

2.2.2 Special Inspection Requirements:

1. Periodic special inspection is required, in accordance with Section 1705A.12.5 of the CBC [DSA-SS & DSA-SS/CC].
2. Where gypsum wallboard is used in suspended ceiling installations, additional inspection shall be in accordance with CBC Section 2503.2 [DSA-SS, DSA-SS/CC].

This supplement expires concurrently with the evaluation report, reissued January 2023.