

## Backer Bar

Provides superior connection shear and pullout strength for handrails, shelves and other wall fixtures

The Backer Bar was specifically designed to meet the demand for the attachment of multiple items and heavier items to interior partitions.

Today's building professionals require solutions to allow the attachment of such products and accessories to the interior partition walls. Traditionally, backing systems have been costly, time-consuming and not necessarily performing to the required code specified load requirements. Backer Bar is designed for use on non-structural and structural studs.

### TYPICAL APPLICATIONS:

- Wall-Mounted Televisions
- Hospital Handrails
- Towel and Shower Bars
- Cabinets and Shelves

### FEATURES AND BENEFITS:

- Installs quickly and easily
- Available in 12", 16" and 24" spacing
- For use on non-structural and structural studs

Canada Patent Pending – 2,811,362

USA Patent – 9,062,455

### PRODUCT DIMENSIONS

Leg: 1-1/4"

Width: 5"

Lengths: For 12", 16" and 24" o.c. stud spacing

### MATERIAL SPECIFICATIONS

Gauge: 20 gauge STR (33mil)

Design Thickness: 0.0346 inches

Coating: G90

Material: Grade 50ksi min. yield strength

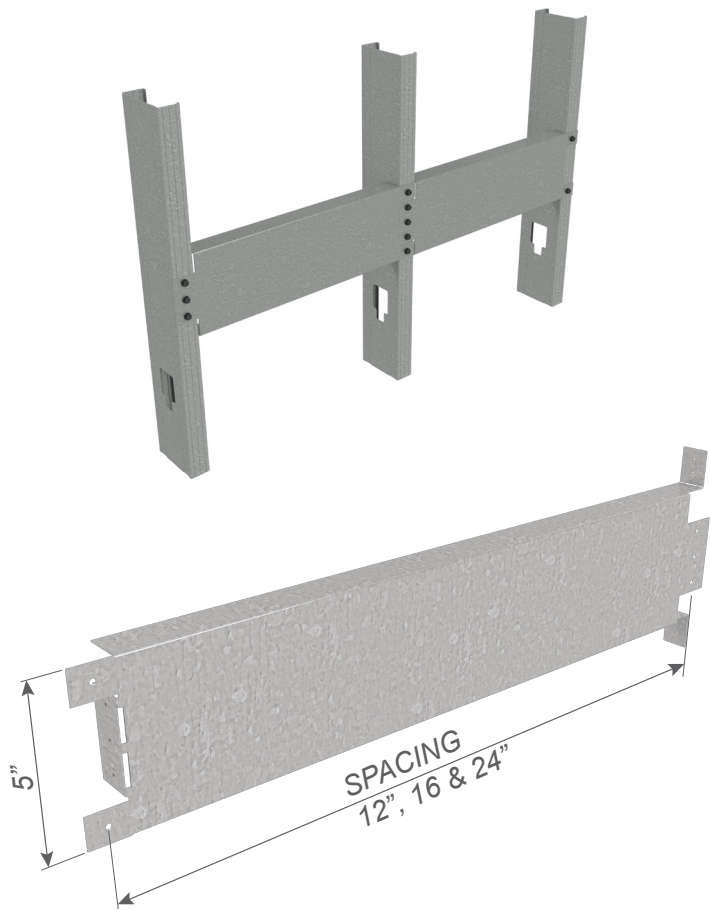

### Backer Bar (BB12, BB16, BB24)

| Product code | Thickness    |                       | Size (in)         | Packaging  |
|--------------|--------------|-----------------------|-------------------|------------|
|              | Mils (Gauge) | Design thickness (in) |                   |            |
| BB12         | 33mil (20ga) | 0.0346                | 1-1/4" x 5" x 12" | Individual |
| BB16         | 33mil (20ga) | 0.0346                | 1-1/4" x 5" x 16" |            |
| BB24         | 33mil (20ga) | 0.0346                | 1-1/4" x 5" x 24" |            |