

TradeReady® Structural Bridging (TDSB)

Provides a quick and efficient method to prevent joist rotation

TradeReady® structural bridging is the third component of the TradeReady® steel floor system. Structural bridging is pre-cut to fit securely between the underside of the floor joists to prevent joist rotation. Structural bridging is an economical alternative to cross bracing, X-bracing or strapping. A continuous row of bridging should be installed every 8' O.C. maximum and staggered for easy attachment. Pre-punched holes for quick attachment.

- Pre-cut to fit 12", 16", 19.2" or 24" spacing.
- Pre-punched holes for quick attachment.
- Available in 18ga only.

Caution: In order to prevent joist rolling, the TDSB Bridging must be tied into the structure or otherwise braced against lateral movement. Note: TDSB Bridging is not required if sheathing is applied to the joists top and bottom.

Product Data & Ordering Information:

Product Code	Gauge (mils)	Depth	Effective Length	Weight	Packaging
TDSB 12"	43mils (18ga)	2-1/2"	12"	0.88 lbs	10 pcs./Carton
TDSB 16"	43mils (18ga)	2-1/2"	16"	1.40 lbs	10 pcs./Carton
TDSB 19.2"	43mils (18ga)	2-1/2"	19.2"	1.66 lbs	10 pcs./Carton
TDSB 24"	43mils (18ga)	2-1/2"	24"	2.10 lbs	10 pcs./Carton

U.S. Patent Nos. 6,301,854; 6,691,478; 6,418,694; 6,691,487; 6,761,005; 7,240,459 Canadian Patent No. 2319346, Mexican Patent No. 243294

Code Approvals & Performance Standards

- **ASTM A653** Standard Specification for Steel Sheet, Zinc-Coated (Galvanized) or Zinc-Iron Alloy-Coated (Galvannealed) by the Hot-Dip Process
- **ASTM A1003** Standard Specification for Steel Sheet, Carbon, Metallic- and Nonmetallic-Coated for Cold-Formed Framing Members
- **SDS For ASTM A1003 Steel Framing Products** For Interior Framing, Exterior Framing and Clips/Accessories

Sustainability Credits For more details and LEED letters contact Technical Services at 888-437-3244 or visit clarkdietrich.com/LEED.

- **LEED v4.1 MR Credit:** Environmental Product Declarations: EPD (1 point) - Sourcing of Raw Materials (up to 2 points) - Material Ingredients (1 point) - Construction and Demolition Waste Management (up to 2 points)
- **LEED v4 MR Credit:** Building Product Disclosure and Optimization: EPD (1 point) - Sourcing of Raw Materials (1 point) - Material Ingredients (1 point) - Construction and Demolition Waste Management (up to 2 points) - Innovation Credit (up to 2 points).

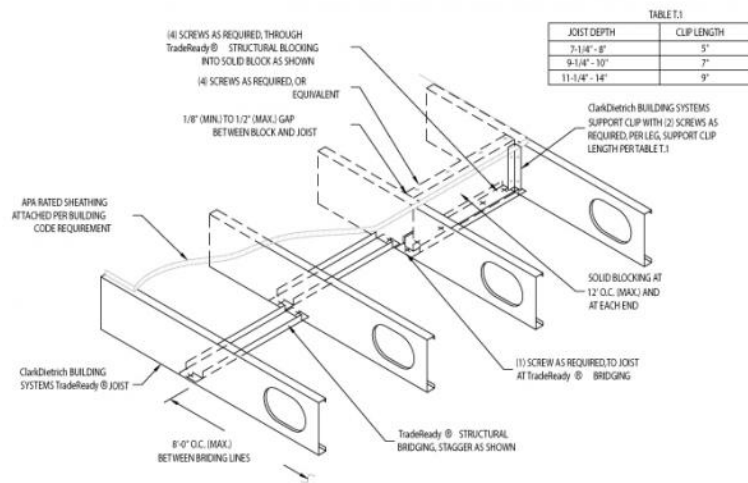
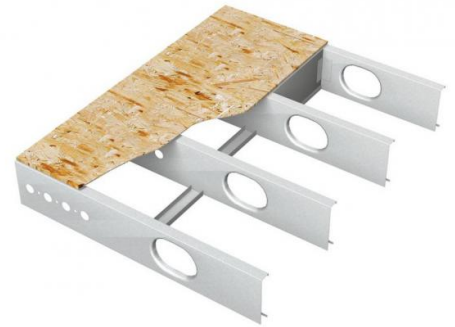
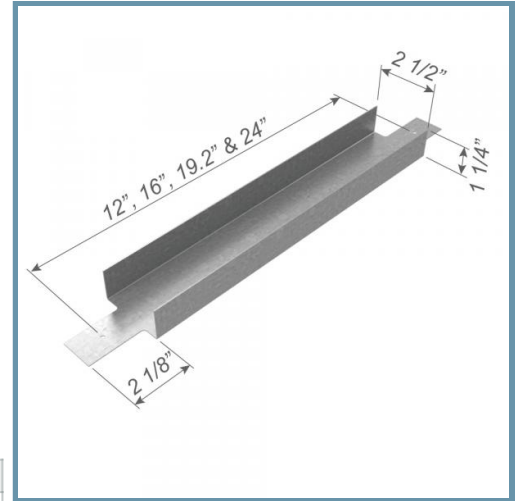

TradeReady STRUCTURAL BRACING DETAIL

ClarkDietrich TradeReady Floor Joist System

For more ClarkDietrich CAD details see: cad.clarkdietrich.com