

GENERAL INFORMATION

BANG-IT®+

Concrete Inserts

PRODUCT DESCRIPTION

Bang-It+ concrete inserts are designed for installation in and through composite steel deck (i.e. “pan-deck”) used to support newly poured concrete floor or roof slabs. The Bang-It+ concrete inserts are specifically designed to provide hanger attachments for mechanical, electrical, plumbing (MEP) and fire protection.

After installation, the protective sleeve of the insert protrudes below the surface of the deck. The sleeves are color coded by size and allow overhead attachment of steel threaded rod in sizes ranging from 1/4" to 3/4" in diameter. The sleeve prevents sprayed fireproofing material and acoustical dampening products from clogging the internal threads of the insert. It also prevents burying, masking or losing the insert location. A hex impact plate offers resistance to rotation within the concrete as a steel threaded rod is being turned during installation.

A push-in thread version is also available which does not require turning the threaded rod or threaded bolt during installation. which can be ideal for applications such as mounting prefabricated hardware and hanger assemblies.

GENERAL APPLICATIONS AND USES

- Hanging Pipe and Sprinkler Systems
- HVAC Ductwork and Strut Channels
- Suspending Trapeze and Cable Trays
- Mechanical Utility Lines
- Conduit and Lighting Systems
- Cracked and Uncracked Concrete

FEATURES AND BENEFITS

- + Fast and simple to install, low installed cost
- + Sturdy base design resists inserts from being kicked over after placement
- + Color coded by size for simple identification, can be further marked by trade and/or utility
- + Inserts can be installed in upper and lower steel deck profiles with limited concrete topping thickness (see installation details)
- + Suitable for seismic and wind loading (see design information)
- + Multi thread inserts allow for multiple diameters using the same part
- + All sizes of multi thread inserts rated for tension and shear loading
- + Push-In thread version does not require turning threaded rod elements during installation
- + Inserts can be considered for use and placement with DEWALT Bridge Bar

APPROVALS AND LISTINGS

- International Code Council, Evaluation Service (ICC-ES), ESR-3657 for concrete-filled decks
- Code compliant with the 2021 IBC/IRC, 2018 IBC/IRC, 2015 IBC/IRC and 2012 IBC/IRC
- Tested in accordance with ASTM E488 and ICC-ES AC446 for use in cracked and uncracked concrete and with the design provisions of ACI 318 (Strength Design method)
- Evaluated and qualified by an accredited independent testing laboratory for recognition in cracked and uncracked concrete as well as seismic and wind loading
- Underwriters Laboratories (UL Listed) - File No. EX1289 and VFXT7.EX1289, see listing for sizes Also UL listed and recognized for use in air handling spaces (i.e. plenum rated locations) in accordance with UL 2043; as referenced by UL 203 for pipe hanger equipment
- FM Approvals (Factory Mutual), Class Numbers 1951, 1952, 1953 for pipe hanger components– see approval for sizes

GUIDE SPECIFICATIONS

CSI Divisions: 03 15 19 - Cast-In Concrete Anchors and 03 16 00 - Concrete Anchors. Concrete inserts shall be Bang-It+ as supplied by DEWALT, Towson, MD. Anchors shall be installed in accordance with published instructions and the Authority Having Jurisdiction.

1-800-4 DEWALT

SECTION CONTENTS

General Information..... 1
 Material Specifications 2
 Installation Specifications 3
 Performance Data (ASD) 6
 Strength Design Information 9
 Design Strength Tables (SD) 13
 Ordering Information 16



BANG-IT+ STEEL DECK INSERTS



BANG-IT+ PUSH-IN THREAD STEEL DECK INSERT

ANCHOR MATERIALS

- Carbon Steel and Engineered Plastic
- ROD/ANCHOR SIZE RANGE (TYP.)**
- 1/4" through 3/4" threaded rod (UNC)

INSERT VERSIONS

- Single Thread (thread-in)
- Multi Thread (thread-in)
- Push-In Thread

SUITABLE BASE MATERIALS

- Normal-weight Concrete
- Lightweight Concrete



MECHANICAL ANCHORS

BANG-IT®+
Concrete Inserts

MATERIAL SPECIFICATIONS

Bang-It+

Anchor Component	Component Material
Insert Body	AISI 1008 Carbon Steel or equivalent
Base Plate	AISI 1008 Carbon Steel or equivalent or Engineered Plastic (polypropylene)
Spring	Steel Music Wire
Protective Sleeve	Engineered Plastic (polypropylene)
Zinc Plating (metal components)	ASTM B633 (Fe/Zn5) Min. Plating requirements for Mild Service Condition

Material Properties for Common Threaded Rods

Description	Steel Specification (ASTM)	Threaded Rod Diameter (inch)	Minimum Yield Strength, f _y (ksi)	Minimum Ultimate Strength, f _u (ksi)
Standard Carbon Steel	A36 or F1554, Grade 36	1/4 to 3/4	36.0	58.0
High Strength Carbon Steel	A193, Grade B7	1/4 to 3/4	105.0	125.0

Inserts may be considered for use in conjunction with all grades of continuously threaded carbon steels (all-thread) that comply with code reference standards and that have thread characteristics comparable with ANSI B1.1 UNC Coarse Thread Series.

Installation Instructions for Bang-It+ Thread-In

CREATE HOLE

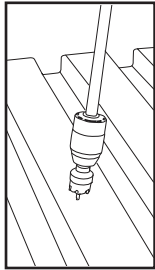

Step 1
Drill or punch a hole in the steel deck to hole size required (e.g. deck driller with hole saw or step bit).

POSITION

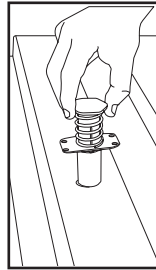

Step 2
Insert plastic sleeve through hole in steel deck.

MOUNT

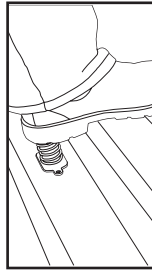

Step 3
Step on or impact insert head to engage through deck. Option: base flange of insert can be attached to steel deck.

ATTACH

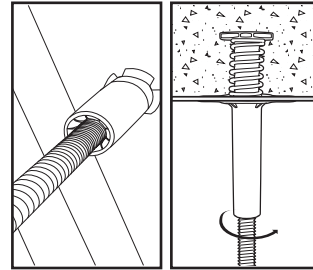

Step 4
Guide threaded rod or bolt through end of plastic sleeve into the insert. Turn until steel element fully threaded. Trim away plastic sleeve as necessary; attach fixtures as applicable.

Installation Instructions for Bang-It+ Push-In

CREATE HOLE

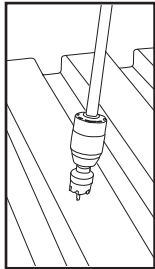

Step 1
Drill or punch a hole in the steel deck to hole size required (e.g. deck driller with hole saw or step bit).

POSITION

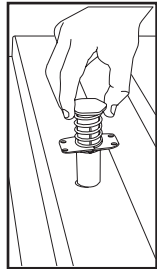

Step 2
Insert plastic sleeve through hole in steel deck.

MOUNT

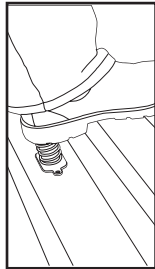

Step 3
Step on or impact insert head to engage through deck. Option: base flange of insert can be attached to steel deck.

ATTACH

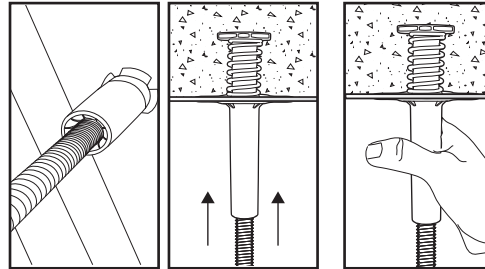

Step 4
Push threaded rod or bolt through end of plastic sleeve into the insert until steel element is fully seated. Attach fixtures as applicable.

Sleeve Removal

The plastic sleeve can be optionally removed (e.g. flush mounted connections) by rotating sleeve approximately 1/2-turn and pulled off.

Note: for UL listing the plastic sleeve must be removed and a nut installed snug against the insert.

INSTALLATION SPECIFICATIONS

Bang-It+ Cast-In-Place Inserts for Concrete Filled Steel Deck Floor and Roof Assemblies

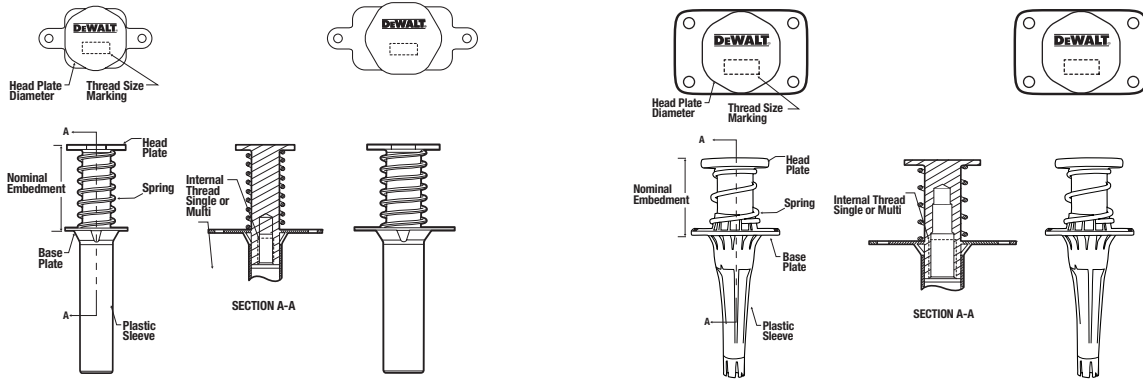

Installation Specifications for Single Thread Bang-It+ Inserts^{1,2,3}

Insert Dimension / Property	Symbol	Units	Nominal Rod/Anchor Size				
			1/4"	3/8"	1/2"	5/8"	3/4"
Outside diameter of steel insert body	d_a	in. (mm)		0.7 (18)			1.0 (25)
Insert head plate diameter	d_{hp}	in. (mm)		1.50 (38)			1.75 (45)
Plastic sleeve diameter	d_s	in. (mm)		27/32 (21)			1-7/32 (31)
Suggested hole size in deck	d_{hole}	in. (mm)		7/8 (22)			1-1/4 (32)
Base plate width	w_{bp}	in. (mm)		1-1/2 (38)			1-1/2 (38)
Nominal embedment depth	h_{nom}	in. (mm)		2 (51)			2 (51)
Effective embedment depth	h_{ef}	in. (mm)		1.75 (45)			1.75 (45)
Minimum member thickness	h_{min}	in. (mm)	See steel deck figures, as applicable				
Minimum spacing distance	s_{min}	in. (mm)	$3h_{ef}$ for lower flute locations; $4d_a$ for upper flute locations				
Minimum edge distance	c_{min}	in. (mm)	See steel deck figures for lower flute edge distances; otherwise use $0.5d_{hp} + 3/4$ (19)				
Insert head plate thickness	t_{hp}	in. (mm)		1/8 (3)			1/8 (3)
Length of plastic sleeve	l_s	in. (mm)		3-3/8 (86)			3-3/8 (86)
UNC internal thread size	-	in. \ TPI	1/4-20	3/8-16	1/2-13	5/8-11	3/4-10
Approx. internal thread length	-	in.	3/8	1/2	5/8	3/4	7/8
Approx. space between base plate opening and start of internal thread, after setting*	-	in.		-3/4			-3/4

*A negative value indicates the internal threads of the insert start below (project through) the base plate.

1. Inserts have internal thread size designations for coarse threads matching the nominal rod / anchor size.
2. The steel body of the inserts project through the steel deck approximately 3/4-inch, after setting.
3. For installation specifications of Multi Thread inserts and Push-In inserts see the next page.

Installation Specifications for Multi Thread Bang-It+ Inserts^{1,2}

Insert Dimension / Property	Symbol	Units	Nominal Rod/Anchor Size												
			1/4" & 3/8" Multi		1/4" & 3/8" & 1/2" Multi			3/8" & 1/2" Multi		3/8" & 1/2" & 5/8" Multi			5/8" & 3/4" Multi		
Outside diameter of the steel insert body	d _a	in. (mm)	0.7 (18)						1.0 (25)						
Insert head plate diameter	d _{hp}	in. (mm)	1.50 (38)						1.75 (45)						
Plastic sleeve diameter	d _s	in. (mm)	27/32 (21)						1-7/32 (32)						
Suggested hole size in deck	d _{hole}	in. (mm)	7/8 (22)						1-1/4 (32)						
Base plate width	W _{bp}	in. (mm)	1-1/2 (38)						1-1/2 (38)						
Nominal embedment depth	h _{nom}	in. (mm)	2 (51)						2-3/8 (60)						
Effective embedment depth	h _{ef}	in. (mm)	1.75 (45)						2.25 (57)						
Minimum member thickness	h _{min}	in. (mm)	See steel deck figures, as applicable												
Minimum spacing distance	S _{min}	in. (mm)	3h _{ef} for lower flute locations; 4d _a for upper flute locations												
Minimum edge distance	C _{min}	in. (mm)	See steel deck figures for lower flute edge distances; otherwise use 0.5d _{hp} + 3/4 (19)												
Insert head plate thickness	t _{hp}	in. (mm)	1/8 (3)						1/8 (3)						
Length of plastic sleeve	ℓ _s	in. (mm)	3-3/8 (86)		3-1/2 (89)			3-3/8 (86)		3-1/2 (89)			3-3/8 (86)		
UNC internal thread size	-	in. \ TPI	1/4-20	3/8-16	1/4-20	3/8-16	1/2-13	3/8-16	1/2-13	3/8-16	1/2-13	5/8-11	5/8-11	3/4-10	
Approx. internal thread length	-	in.	3/8	1/2	5/16	3/8	1/2	7/16	9/16	3/8	1/2	5/8	5/8	3/4	
Approx. space between base plate opening and start of internal thread, after setting*	-	in	0	-3/4	3/4	0	-3/4	1/8	-3/4	1	1/4	-3/4	1/2	-3/4	

*A negative value indicates the internal threads of the insert start below (project through) the base plate.

1. Inserts have internal thread size designations for coarse threads matching the nominal rod / anchor size.
2. The steel body of the inserts project through the steel deck approximately 3/4-inch, after setting.

Installation Specifications for Bang-It+ Push-In Inserts^{1,2}

Insert Dimension / Property	Symbol	Units	Nominal Rod/Anchor Size	
			3/8"	1/2"
Outside diameter of the steel insert body	d _a	in. (mm)	1.0 (25)	1.125 (29)
Insert head plate diameter	d _{hp}	in. (mm)	1.9 (48)	2.2 (56)
Plastic sleeve diameter	d _s	in. (mm)	1-3/32 (28)	1-7/32 (31)
Suggested hole size in deck	d _{hole}	in. (mm)	1-1/4 (32)	1-1/4 (32)
Base plate width	W _{bp}	in. (mm)	1-1/2 (38)	1-1/2 (38)
Nominal embedment depth	h _{nom}	in. (mm)	1-11/16 (42)	1-7/8 (48)
Effective embedment depth	h _{ef}	in. (mm)	1.5 (38)	1.7 (43)
Minimum member thickness	h _{min}	in. (mm)	See steel deck figures, as applicable	
Minimum spacing distance	S _{min}	in. (mm)	3h _{ef} for lower flute locations; 4d _a for upper flute locations	
Minimum edge distance	C _{min}	in. (mm)	See steel deck figures for lower flute edge distances; otherwise use 0.5d _{hp} + 3/4 (19)	
Insert head plate thickness	t _{hp}	in. (mm)	3/16 (5)	3/16 (5)
Length of plastic sleeve	ℓ _s	in. (mm)	3-1/2 (89)	3-1/2 (89)
UNC internal thread size	-	in. \ TPI	3/8-16	1/2-13
Approx. internal thread length	-	in.	5/8	11/16
Approx. space between base plate opening and start of internal thread, after setting	-	in	7/16	5/8

1. Inserts have internal thread size designations for coarse threads matching the nominal rod / anchor size.
2. The steel body of the inserts project through the steel deck approximately 3/4-inch, after setting.

[A] Bang-It+ Inserts Installed in Soffit of Concrete Filled Steel Deck Floor and Roof Assemblies, 4-1/2 -inch W-Deck^{1,2,3,4}

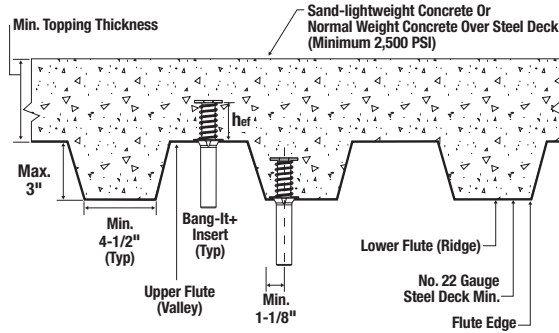

[B] Bang-It+ Inserts Installed in Soffit of Concrete Filled Steel Deck Floor and Roof Assemblies, B-Deck^{1,2,3,5,6,7}

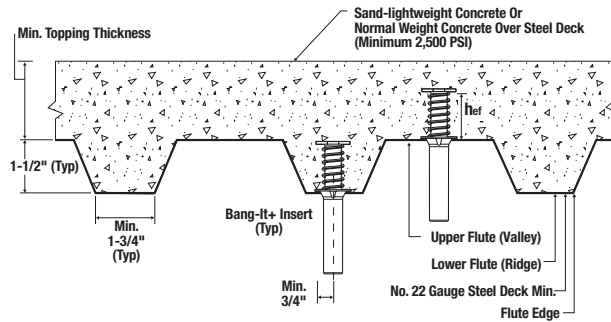

[C] Bang-It+ Inserts Installed in Soffit of Concrete Filled Steel Deck Floor and Roof Assemblies, 3-7/8 -inch W-Deck^{1,2,3,8,9}

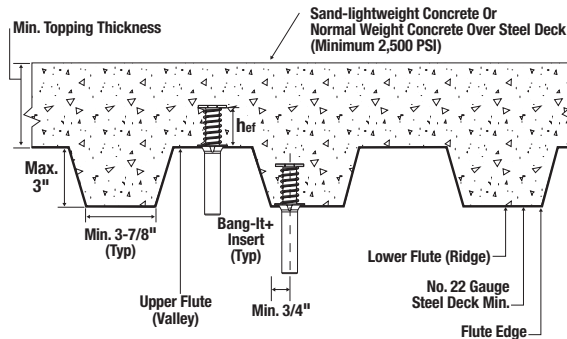

- [A, B & C] Inserts may be placed in the upper flute or lower flute of the steel deck assembly. Inserts in the lower flute require a minimum 1.5" of concrete topping thickness (min. thick in Figures) from the top of the upper flute, except for the 3/8 & 1/2 & 5/8-inch multi insert and 5/8 & 3/4-inch multi insert which require a minimum of 2" of concrete topping thickness. Upper flute installations require a minimum 3" concrete topping thickness from the top of the upper flute.
- [A, B & C] Axial spacing for inserts along the upper flute length shall be $4d_a$ minimum; axial spacing along the lower flute length shall be $3h_f$ minimum.
- [A, B & C] Upper flute Bang-It+ inserts are not subject to steel deck dimension limitations, or the minimum steel deck gauge limitations.
- [A] Inserts in the lower flute of 4-1/2-inch W-Deck may be installed with a maximum 1-1/8 -inch offset in either direction from the center of the flute. The offset distance may be increased for flute widths greater than those shown provided the minimum lower flute edge distance of 1-1/8 -inch is also satisfied.
- [B] Inserts in the lower flute of B-Deck may be installed with a maximum 1/8 -inch offset in either direction from the center of the flute. The offset distance may be increased for flute widths greater than those shown provided the minimum lower flute edge distance of 3/4 -inch is also satisfied.
- [B] Lower flute installations of B-Deck with flutes widths greater than 1-3/4 -inch are permitted.
- [B] Lower flute installations of B-Deck in flute depths greater than 1-1/2 -inch are permitted provided the minimum edge distance of 3/4 -inch is met and the minimum lower flute width is increased proportionally (e.g. applicable to a lower flute depth of 2-inch with a minimum lower flute width of 2-1/4 -inch).
- [C] Inserts in the lower flute of 3-7/8-inch W-Deck may be installed with a maximum 1-3/16 -inch offset in either direction from the center of the flute. The offset distance may be increased for flute widths greater than those shown provided the minimum lower flute edge distance of 3/4 -inch is also satisfied.
- [C] Inserts in upper flute may be installed anywhere across upper flute provided minimum edge distances are maintained; see insert design information tables, as applicable.

MECHANICAL ANCHORS

BANG-IT+[®]
Concrete Inserts

TECHNICAL GUIDE – MECHANICAL ANCHORS ©2024 DEWALT – REV G

PERFORMANCE DATA (ASD)

Allowable Design Values for Inserts in Uncracked Concrete (lbs)^{1,2,3,4,5,6,7,8,9,10,11,12}

Deck Profile Type	Load Type	Bang-It+ Single Thread Inserts										Bang-It+ Push-In Thread Inserts					
		1/4-inch		3/8-inch		1/2-inch		5/8-inch		3/4-inch		3/8-inch		1/2-inch			
		Upper	Lower	Upper	Lower	Upper	Lower	Upper	Lower	Upper	Lower	Upper	Lower	Upper	Lower		
Fig. A	Tension	1,530	1,090	1,530	1,090	1,530	1,090	1,530	1,090	1,530	1,090	1,530	1,090	1,215	910	1,465	1,055
	Shear	805	805	925	925	925	925	925	925	925	925	925	925	1,340	930	2,795	1,235
Fig. B	Tension	1,530	435	1,530	435	1,530	435	1,530	435	1,530	435	1,530	435	1,215	405	1,465	430
	Shear	730	730	845	845	845	845	1,205	1,205	1,205	1,205	1,205	1,205	1,340	930	2,795	1,035
Fig. C	Tension	1,530	985	1,530	985	1,530	985	1,530	985	1,530	985	1,530	985	1,215	810	1,465	945
	Shear	730	730	845	845	845	845	1,205	1,205	1,205	1,205	1,205	1,205	1,340	930	2,795	1,035
Deck Profile Type	Load Type	Bang-It+ Multi Thread Inserts															
		1/4 & 3/8 Multi				1/4 & 3/8 & 1/2 Multi				3/8 & 1/2 Multi							
		1/4-inch		3/8-inch		1/4-inch		3/8-inch		1/2-inch		3/8-inch		1/2-inch			
		Upper	Lower	Upper	Lower	Upper	Lower	Upper	Lower	Upper	Lower	Upper	Lower	Upper	Lower	Upper	Lower
Fig. A	Tension	865	865	1,530	1,090	1,530	1,090	1,530	1,090	1,530	1,090	1,530	1,090	1,530	1,090	1,530	1,090
	Shear	675	470	925	925	675	515	1,435	840	1,690	840	965	845	1,690	925		
Fig. B	Tension	865	435	1,530	435	1,530	435	1,530	435	1,530	435	1,530	435	1,530	435	1,530	435
	Shear	675	470	925	845	675	515	1,435	580	1,690	725	965	845	1,690	845		
Fig. C	Tension	865	1,090	1,530	1,090	1,530	1,090	1,530	1,090	1,530	1,090	1,530	1,090	1,530	1,090	1,530	1,090
	Shear	675	470	925	845	675	515	1,435	580	1,690	725	965	845	1,690	845		
Deck Profile Type	Load Type	Bang-It+ Multi Thread Inserts (Continued)															
		3/8 & 1/2 & 5/8 Multi						5/8 & 3/4 Multi									
		3/8-inch		1/2-inch		5/8-inch		5/8-inch		3/4-inch							
		Upper	Lower	Upper	Lower	Upper	Lower	Upper	Lower	Upper	Lower	Upper	Lower	Upper	Lower		
Fig. A	Tension	2,230	1,485	2,230	1,485	2,230	1,485	2,230	1,485	2,230	1,485	2,230	1,485	2,230	1,485		
	Shear	1,975	1,020	3,280	1,020	3,280	1,020	3,280	1,020	2,280	1,235	2,625	1,235				
Fig. B	Tension	2,230	495	2,230	495	2,230	495	2,230	495	2,230	495	2,230	495	2,230	495		
	Shear	1,975	880	3,280	880	3,280	880	3,280	880	2,280	770	2,625	770				
Fig. C	Tension	2,230	1,485	2,230	1,485	2,230	1,485	2,230	1,485	2,230	1,485	2,230	1,485	2,230	1,485		
	Shear	1,975	880	3,280	880	3,280	880	3,280	880	2,280	770	2,625	770				

Allowable Stress Design Values in tables for inserts are provided for illustration and applicable only when the following design assumptions are followed:

- Concrete compressive strength, f'_c , 3000 psi for sand-lightweight concrete. For normalweight concrete, tabulated tension design values may be increased by 17 percent for the given conditions, except for 1/4-inch-diameters where no increase is permitted.
- Single anchors with static loads; installation in upper and lower flute locations in concrete-filled steel deck in accordance with Figures A, B or C, as applicable.
- Concrete determined to remain uncracked for the life of the anchorage.
- Load combinations from ACI 318 (-19 or -14) 5.3 or ACI 318-11 9.2, as applicable (no seismic loading considered).
- 30% dead load and 70% live load, controlling load combination 1.2D + 1.6L.
- Calculation of the weighted average for $\alpha = 1.2 \cdot 0.3 + 1.6 \cdot 0.7 = 1.48$.
- $h \geq h_{min}$ according to Figures A, B or C, as applicable.
- Values are for Condition B where supplementary reinforcement in accordance with ACI 318-19 Section 17.5.3, ACI 318-14 17.3.3 or ACI 318-11 D.4.3, as applicable, is not provided.
- Assuming no edge distance influence with $\Psi_{ed,N} = 1.0$ in tension for upper flute anchors.
- Assuming no edge distance ($c_{a1} \geq 3h_{ef}$) or corner distance influence ($c_{a2} \geq 1.5c_{a1}$) for upper flute anchors in shear. Shear loads may be applied in any direction.
- For lower flute anchors in accordance with Figure A, the near edge distance, $c_{a,min}$, is 1.125-inch. For lower flute anchors in accordance with Figure B, the near edge distance, $c_{a,min}$, is 0.75-inch. For lower flute anchors in accordance with Figure C, the near edge distance, $c_{a,min}$, is 0.75-inch.
- The allowable loads shown in the table are for the inserts only. The design professional is responsible for checking threaded rod strength in tension, shear and combined tension and shear, as applicable. For designs that include combined tension and shear, the interaction of tension and shear loads must be calculated in accordance with ACI 318 (-19 or -14) Chapter 17 or ACI 318-11 Appendix D, as applicable.

MECHANICAL ANCHORS

BANG-IT+[®]
Concrete Inserts

Allowable Design Values for Inserts in Cracked Concrete (lbs)^{1,2,3,4,5,6,7,8,9,10,11,12}

Deck Profile Type	Load Type	Bang-It+ Single Thread Inserts										Bang-It+ Push-In Thread Inserts			
		1/4-inch		3/8-inch		1/2-inch		5/8-inch		3/4-inch		3/8-inch		1/2-inch	
		Upper	Lower	Upper	Lower	Upper	Lower	Upper	Lower	Upper	Lower	Upper	Lower	Upper	Lower
Fig. A	Tension	1,225	875	1,225	875	1,225	875	1,225	875	1,225	875	970	730	1,170	845
	Shear	805	805	925	925	925	925	925	925	925	925	1,340	930	2,795	1,235
Fig. B	Tension	1,225	350	1,225	350	1,225	350	1,225	350	1,225	350	970	325	1,170	345
	Shear	730	730	845	845	845	845	1,205	1,205	1,205	1,205	1,340	930	2,795	1,035
Fig. C	Tension	1,225	785	1,225	785	1,225	785	1,225	785	1,225	785	970	645	1,170	760
	Shear	730	730	845	845	845	845	1,205	1,205	1,205	1,205	1,340	930	2,795	1,035
Deck Profile Type	Load Type	Bang-It+ Multi Thread Inserts													
		1/4 & 3/8 Multi				1/4 & 3/8 & 1/2 Multi						3/8 & 1/2 Multi			
		1/4-inch		3/8-inch		1/4-inch		3/8-inch		1/2-inch		3/8-inch		1/2-inch	
		Upper	Lower	Upper	Lower	Upper	Lower	Upper	Lower	Upper	Lower	Upper	Lower	Upper	Lower
Fig. A	Tension	865	865	1,225	875	1,225	875	1,225	875	1,225	875	1,225	875	1,225	875
	Shear	675	470	925	925	675	515	1,435	840	1,690	840	965	845	1,690	925
Fig. B	Tension	865	350	1,225	350	1,225	350	1,225	350	1,225	350	1,225	350	1,225	350
	Shear	675	470	925	845	675	515	1,435	580	1,690	725	965	845	1,690	845
Fig. C	Tension	865	865	1,225	875	1,225	875	1,225	875	1,225	875	1,225	875	1,225	875
	Shear	675	470	925	845	675	515	1,435	580	1,690	725	965	845	1,690	845
Deck Profile Type	Load Type	Bang-It+ Multi Thread Inserts (Continued)													
		3/8 & 1/2 & 5/8 Multi						5/8 & 3/4 Multi							
		3/8-inch		1/2-inch		5/8-inch		5/8-inch		3/4-inch					
		Upper	Lower	Upper	Lower	Upper	Lower	Upper	Lower	Upper	Lower				
Fig. A	Tension	1,785	1,190	1,785	1,190	1,785	1,190	1,785	1,190	1,785	1,190	1,785	1,190		
	Shear	1,975	1,020	3,280	1,020	3,280	1,020	2,280	1,235	2,625	1,235				
Fig. B	Tension	1,785	395	1,785	395	1,785	395	1,785	395	1,785	395	1,785	395		
	Shear	1,975	880	3,280	880	3,280	880	2,280	770	2,625	770				
Fig. C	Tension	1,785	1,190	1,785	1,190	1,785	1,190	1,785	1,190	1,785	1,190	1,785	1,190		
	Shear	1,975	880	3,280	880	3,280	880	2,280	770	2,625	770				

- Concrete compressive strength, f'c, = 3000 psi for sand-lightweight concrete. For normalweight concrete, tabulated tension design values may be increased by 17 percent for the given conditions, except for 1/4-inch-diameters where no increase is permitted.
- Single anchors with static loads; installation in upper and lower flute locations in concrete-filled steel deck in accordance with Figures A, B or C, as applicable.
- Concrete determined to be cracked for the life of the anchorage.
- Load combinations from ACI 318 (-19 or -14) 5.3 or ACI 318-11 9.2, as applicable (no seismic loading considered).
- 30% dead load and 70% live load, controlling load combination 1.2D + 1.6L.
- Calculation of the weighted average for $\alpha = 1.2 \cdot 0.3 + 1.6 \cdot 0.7 = 1.48$.
- $h \geq h_{min}$ according to Figures A, B or C, as applicable.
- Values are for Condition B where supplementary reinforcement in accordance with ACI 318-19 Section 17.5.3, ACI 318-14 17.3.3 or ACI 318-11 D.4.3, as applicable, is not provided.
- Assuming no edge distance influence with $\Psi_{ed,N} = 1.0$ in tension for upper flute anchors.
- Assuming no edge distance ($c_{a1} \geq 3h_{ef}$) or corner distance influence ($c_{a2} \geq 1.5c_{a1}$) for upper flute anchors in shear. Shear loads may be applied in any direction.
- For lower flute anchors in accordance with Figure A, the near edge distance, $c_{a,min}$, is 1.125-inch. For lower flute anchors in accordance with Figure B, the near edge distance, $c_{a,min}$, is 0.75-inch. For lower flute anchors in accordance with Figure C, the near edge distance, $c_{a,min}$, is 0.75-inch.
- The allowable loads shown in the table are for the inserts only. The design professional is responsible for checking threaded rod strength in tension, shear and combined tension and shear, as applicable. For designs that include combined tension and shear, the interaction of tension and shear loads must be calculated in accordance with ACI 318 (-19 or -14) Chapter 17 or ACI 318-11 Appendix D, as applicable.

UL Listings and FM Approvals for Supporting Fire Protection Services & Automatic Sprinkler Systems¹

Listing/Approval	Bang-It+ Single Thread Inserts										Bang-It+ Push-In Inserts			
	1/4"		3/8"		1/2"		5/8"		3/4"		3/8"		1/2"	
	Upper	Lower	Upper	Lower	Upper	Lower	Upper	Lower	Upper	Lower	Upper	Lower	Upper	Lower
UL Max. Pipe Size	N/A	N/A	4"	4"	8"	8"	8"	8"	8"	8"	4"	4"	8"	8"
FM Max. Pipe Size	N/A	N/A	4"	4"	8"	8"	12"	-	12"	-	4"	4"	8"	8"
Listing/Approval	Bang-It+ Multi Thread Inserts													
	1/4 & 3/8 Multi				1/4 & 3/8 & 1/2 Multi						3/8 & 1/2 Multi			
	1/4"		3/8"		1/4"		3/8"		1/2"		3/8"		1/2"	
	Upper	Lower	Upper	Lower	Upper	Lower	Upper	Lower	Upper	Lower	Upper	Lower	Upper	Lower
UL Max. Pipe Size	N/A	N/A	4"	4"	N/A	N/A	4"	4"	8"	8"	4"	4"	8"	8"
FM Max. Pipe Size	N/A	N/A	4"	4"	N/A	N/A	4"	4"	8"	8"	4"	4"	8"	8"
Listing/Approval	Bang-It+ Multi Thread Inserts (Continued)													
	3/8 & 1/2 & 5/8 Multi						5/8 & 3/4 Multi							
	3/8"		1/2"		5/8"		5/8"		3/4"					
	Upper	Lower	Upper	Lower	Upper	Lower	Upper	Lower	Upper	Lower				
UL Max. Pipe Size	4"	4"	8"	8"	10"	10"	10"	10"	10"	10"				
FM Max. Pipe Size	4"	4"	8"	8"	12"	12"	12"	12"	12"	12"				

Underwriters Laboratories (UL Listed) – File No. EX1289
 FM Approvals (Factory Mutual)

1. Anchors with installation in upper and lower flute locations in concrete-filled steel deck in accordance with Figures A, B or C, as applicable.



STRENGTH DESIGN INFORMATION

Design Information for Bang-It+ Single Thread Inserts^{1,2,3,4,5,6}

Design Information / Insert Property		Symbol	Units	1/4"	3/8"	1/2"	5/8"	3/4"
Outside diameter of the steel insert body		d_a	in. (mm)		0.7 (18)			1.0 (25)
Insert head net bearing area		A_{brg}	in ² (mm ²)		1.20 (762)			1.40 (903)
Effective embedment depth		h_{ef}	in. (mm)		1.75 (45)			1.75 (45)
STEEL STRENGTH IN TENSION (ACI 318-19 17.6.1, ACI 318-14 17.4.1 or ACI 318-11 D.5.1)								
According to Figures A, B & C	Steel strength in tension of single insert	$N_{sa,insert}$	lb (kN)	3,955 (17.6)	9,480 (42.2)	9,850 (43.5)		11,985 (53.3)
	Steel strength in tension of single insert, seismic	$N_{sa,insert,eq}$	lb (kN)	3,955 (17.6)	9,480 (42.2)	9,850 (43.5)		11,985 (53.3)
Reduction factor, steel strength in tension		ϕ	-			0.65		
CONCRETE BREAKOUT STRENGTH IN TENSION (ACI 318-19 17.6.2, ACI 318-14 17.4.2 or ACI 318-11 D.5.2)								
Effectiveness factor for cracked concrete		k_c	-			24 (for SI use a value of 10)		
Modification factor for uncracked concrete		$\Psi_{C,N}$	-			1.25		
Reduction factor, concrete strength in tension		ϕ	-			0.70		
STEEL STRENGTH IN SHEAR (ACI 318-19 17.7.1, ACI 318-14 17.5.1 or ACI 318-11 D.6.1)								
According to Figure A	Steel strength in shear of single insert, in lower or upper flute	$V_{sa,insert,deck}$	lb (kN)	1,980 (8.8)		2,280 (10.1)		3,075 (13.7)
	Steel strength in shear of single insert, seismic	$V_{sa,insert,eq,deck}$	lb (kN)	1,980 (8.8)		2,280 (10.1)		2,695 (12.0)
According to Figures B & C	Steel strength in shear of single insert, in lower or upper flute	$V_{sa,insert,deck}$	lb (kN)	1,805 (8.0)		2,080 (9.3)		2,975 (13.2)
	Steel strength in shear of single insert, seismic	$V_{sa,insert,eq,deck}$	lb (kN)	1,805 (8.0)		2,080 (9.3)		2,695 (12.0)
Reduction factor, concrete strength in tension		ϕ	-			0.60		
<ol style="list-style-type: none"> Concrete must have a compressive strength f'_c of 2,500 psi minimum. Installation must comply with published instructions. Design of headed cast-in specialty inserts shall be in accordance with the provisions of ACI 318 (-19 or -14) Chapter 17 or ACI 318-11 Appendix D, as applicable, for cast-in headed anchors. Concrete breakout strength must also be in accordance with steel deck figures, as applicable. Strength reduction factors for the inserts shall be taken from ACI 318-19 17.5.3, ACI 318-14 17.3.3 or ACI 318-11 D.4.3, as applicable, for cast-in headed anchors. Strength reduction factors for load combinations in accordance with ACI 318 (-19 or -14) 5.3 or ACI 318-11 9.2, as applicable, governed by steel strength of the insert are tabulated. Strength reduction values correspond to brittle steel elements. The value of ϕ applies when the load combinations of 2021 IBC Section 1605.1 or 2018, 2015 and 2012 IBC 1605.2, ACI 318 (-19 or -14) Section 5.3 or ACI 318-11 9.2, as applicable, are used in accordance with ACI 318-19 17.5.3, ACI 318-14 17.3.3 or ACI 318-11 D.4.3, as applicable. If the load combinations of ACI 318-11 Appendix C are used, the appropriate value of ϕ must be determined in accordance with ACI 318-11 D.4.4. Minimum spacing distance between anchors and minimum edge distances for cast-in headed anchors shall be in accordance with steel deck figures, as applicable and the installation tables for the inserts. The strengths shown in the table are for inserts only. Design professional is responsible for checking threaded rod strength in tension, shear, and combined tension and shear, as applicable. See steel design information for common threaded rod elements. The tabulated seismic values for steel strength of the inserts are applicable to installations in the lower flute or upper flute of the indicated steel deck figures, as applicable. 								



Design Information for Bang-It+ Multi Thread Inserts^{1,2,3,4,5,6}

Design Information		Symbol	Units	1/4 & 3/8 Multi		1/4 & 3/8 & 1/2 Multi			3/8 & 1/2 Multi		3/8 & 1/2 & 5/8 Multi			5/8 & 3/4 Multi	
				1/4"	3/8"	1/4"	3/8"	1/2"	3/8"	1/2"	3/8"	1/2"	5/8"	5/8"	3/4"
Outside diameter of the steel insert body		d_a	in. (mm)	0.7 (18)						1.0 (25)					
Insert head net bearing area		A_{brg}	in ² (mm ²)	1.20 (762)						1.40 (903)					
Effective embedment depth		h_{ef}	in. (mm)	1.75 (45)						1.75 (45)					
STEEL STRENGTH IN TENSION (ACI 318-19 17.6.1, ACI 318-14 17.4.1 or ACI 318-11 D.5.1)															
According to Figures A, B & C	Steel strength in tension of single insert	$N_{sa,insert}$	lb (kN)	1,965 (8.7)	9,480 (42.2)	3,545 (15.8)	8,565 (38.1)	9,850 (43.8)	9,480 (42.2)	9,850 (43.8)	11,485 (51.1)	17,365 (77.2)	20,805 (92.5)		
	Steel strength in tension of single insert, seismic	$N_{sa,insert,eq}$	lb (kN)	1,965 (8.7)	9,480 (42.2)	3,545 (15.8)	8,565 (38.1)	9,850 (43.8)	9,480 (42.2)	9,850 (43.8)	11,485 (51.1)	17,365 (77.2)	20,805 (92.5)		
Reduction factor, steel strength in tension		ϕ	-	0.65						0.65					
CONCRETE BREAKOUT STRENGTH IN TENSION (ACI 318-19 17.6.2, ACI 318-14 17.4.2 or ACI 318-11 D.5.2)															
Effectiveness factor for cracked concrete		k_c	-	24 (for SI use a value of 10)											
Modification factor for uncracked concrete		$\Psi_{c,N}$	-	1.25											
Reduction factor, concrete strength in tension		ϕ	-	0.70											
STEEL STRENGTH IN SHEAR (ACI 318-19 17.7.1, ACI 318-14 17.5.1 or ACI 318-11 D.6.1)															
According to Figure A	Steel strength in shear of single insert, in upper flute	$V_{sa,insert,deck}$	lb (kN)	1,670 (7.4)	2,280 (10.2)	1,670 (7.4)	3,545 (15.8)	4,165 (18.5)	2,375 (10.6)	4,165 (18.6)	4,875 (21.7)	8,090 (36.0)	8,090 (36.0)	5,620 (25.0)	6,475 (28.8)
	Steel strength in shear of single insert, in lower flute	$V_{sa,insert,deck}$	lb (kN)	1,165 (5.2)	2,280 (10.2)	1,275 (5.7)	2,070 (9.2)	2,070 (9.2)	2,080 (9.3)	2,280 (10.2)	2,515 (11.2)	2,515 (11.2)	3,045 (13.5)		
	Steel strength in shear of single insert, seismic	$V_{sa,insert,eq,deck}$	lb (kN)	395 (1.8)	2,280 (10.2)	395 (1.8)	1,435 (6.4)	1,790 (8.0)	2,080 (9.3)	2,280 (10.2)	2,175 (9.7)	2,175 (9.7)	1,905 (8.5)		
According to Figures B & C	Steel strength in shear of single insert, in upper flute	$V_{sa,insert,deck}$	lb (kN)	1,670 (7.4)	2,280 (10.2)	1,670 (7.4)	3,545 (15.8)	4,165 (18.5)	2,375 (10.6)	4,165 (18.5)	4,875 (21.7)	8,090 (36.0)	8,090 (36.0)	5,620 (25.0)	6,475 (28.8)
	Steel strength in shear of single insert, in lower flute	$V_{sa,insert,deck}$	lb (kN)	1,165 (5.2)	2,080 (9.3)	1,275 (5.7)	1,435 (6.4)	1,790 (8.0)	2,080 (9.3)	2,080 (9.3)	2,175 (9.7)	2,175 (9.7)	1,905 (8.5)		
	Steel strength in shear of single insert, seismic	$V_{sa,insert,eq,deck}$	lb (kN)	395 (1.8)	2,080 (9.3)	395 (1.8)	1,435 (6.4)	1,790 (8.0)	2,080 (9.3)	2,080 (9.3)	2,175 (9.7)	2,175 (9.7)	1,905 (8.5)		
Reduction factor, concrete strength in tension		ϕ	-	0.60						0.60					

- Concrete must have a compressive strength f'_c of 2,500 psi minimum. Installation must comply with published instructions.
- Design of headed cast-in specialty inserts shall be in accordance with the provisions of ACI 318 (-19 or -14) Chapter 17 or ACI 318-11 Appendix D, as applicable, for cast-in headed anchors. Concrete breakout strength must also be in accordance with steel deck figures, as applicable.
- Strength reduction factors for the inserts shall be taken from ACI 318-19 17.5.3, ACI 318-14 17.3.3 or ACI 318-11 D.4.3, as applicable, for cast-in headed anchors. Strength reduction factors for load combinations in accordance with ACI 318 (-19 or -14) 5.3 or ACI 318-11 9.2, as applicable, governed by steel strength of the insert are tabulated. Strength reduction values correspond to brittle steel elements. The value of ϕ applies when the load combinations of 2021 IBC Section 1605.1 or 2018, 2015 and 2012 IBC 1605.2, ACI 318 (-19 or -14) Section 5.3 or ACI 318-11 9.2, as applicable, are used in accordance with ACI 318-19 17.5.3, ACI 318-14 17.3.3 or ACI 318-11 D.4.3, as applicable. If the load combinations of ACI 318-11 Appendix C are used, the appropriate value of ϕ must be determined in accordance with ACI 318-11 D.4.4.
- Minimum spacing distance between anchors and minimum edge distances for cast-in headed anchors shall be in accordance with steel deck figures, as applicable and the installation tables for the inserts.
- The strengths shown in the table are for inserts only. Design professional is responsible for checking threaded rod strength in tension, shear, and combined tension and shear, as applicable. See steel design information for common threaded rod elements.
- The tabulated seismic values for steel strength of the inserts are applicable to installations in the lower flute or upper flute of the indicated steel deck figures, as applicable.

MECHANICAL ANCHORS

BANG-IT[®]
Concrete Inserts



Design Information for Bang-It+ Push-In Thread Inserts^{1,2,3,4,5,6}

Design Information		Symbol	Units	3/8"	1/2"
Outside diameter of the steel insert body		d_a	in. (mm)	1.0 (25)	1.125 (29)
Insert head net bearing area		A_{brg}	in ² (mm ²)	2.0 (1290)	2.7 (1742)
Effective embedment depth		h_{ef}	in. (mm)	1.5 (38)	1.7 (43)
STEEL STRENGTH IN TENSION (ACI 318-19 17.6.1, ACI 318-14 17.4.1 or ACI 318-11 D.5.1)					
According to Figures A, B & C	Steel strength in tension of single insert	$N_{sa,insert}$	lb (kN)	11,265 (50.1)	17,595 (78.3)
	Steel strength in tension of single insert, seismic	$N_{sa,insert,eq}$	lb (kN)	11,265 (50.1)	17,595 (78.3)
Reduction factor, steel strength in tension			ϕ	-	0.65
CONCRETE BREAKOUT STRENGTH IN TENSION (ACI 318-19 17.6.2, ACI 318-14 17.4.2 or ACI 318-11 D.5.2)					
Effectiveness factor for cracked concrete			k_c	-	24 (for SI use a value of 10)
Modification factor for uncracked concrete			$\Psi_{C,N}$	-	1.25
Reduction factor, concrete strength in tension			ϕ	-	0.70
STEEL STRENGTH IN SHEAR (ACI 318-19 17.7.1, ACI 318-14 17.5.1 or ACI 318-11 D.6.1)					
According to Figure A	Steel strength in shear of single insert, in upper flute	$V_{sa,insert,deck}$	lb (kN)	3,305 (14.7)	6,900 (30.7)
	Steel strength in shear of single insert, in lower flute	$V_{sa,insert,deck}$	lb (kN)	2,295 (10.2)	3,045 (13.5)
	Steel strength in shear of single insert, seismic	$V_{sa,insert,eq,deck}$	lb (kN)	2,295 (10.2)	3,045 (13.5)
According to Figures B & C	Steel strength in shear of single insert, in upper flute	$V_{sa,insert,deck}$	lb (kN)	3,305 (14.7)	6,900 (30.7)
	Steel strength in shear of single insert, in lower flute	$V_{sa,insert,deck}$	lb (kN)	2,295 (10.2)	2,535 (11.3)
	Steel strength in shear of single insert, seismic	$V_{sa,insert,eq,deck}$	lb (kN)	2,295 (10.2)	2,535 (11.3)
Reduction factor, concrete strength in tension			ϕ	-	0.60

- Concrete must have a compressive strength f'_c of 2,500 psi minimum. Installation must comply with published instructions.
- Design of headed cast-in specialty inserts shall be in accordance with the provisions of ACI 318 (-19 or -14) Chapter 17 or ACI 318-11 Appendix D, as applicable, for cast-in headed anchors. Concrete breakout strength must also be in accordance with steel deck figures, as applicable.
- Strength reduction factors for the inserts shall be taken from ACI 318-19 17.5.3, ACI 318-14 17.3.3 or ACI 318-11 D.4.3, as applicable, for cast-in headed anchors. Strength reduction factors for load combinations in accordance with ACI 318 (-19 or -14) 5.3 or ACI 318-11 9.2, as applicable, governed by steel strength of the insert are tabulated. Strength reduction values correspond to brittle steel elements. The value of ϕ applies when the load combinations of 2021 IBC Section 1605.1 or 2018, 2015 and 2012 IBC 1605.2, ACI 318 (-19 or -14) Section 5.3 or ACI 318-11 9.2, as applicable, are used in accordance with ACI 318-19 Section 17.5.3, ACI 318-14 17.3.3 or ACI 318-11 D.4.3, as applicable. If the load combinations of ACI 318-11 Appendix C are used, the appropriate value of ϕ must be determined in accordance with ACI 318-11 D.4.4.
- Minimum spacing distance between anchors and minimum edge distances for cast-in headed anchors shall be in accordance with steel deck figures, as applicable and the installation tables for the inserts.
- The strengths shown in the table are for inserts only. Design professional is responsible for checking threaded rod strength in tension, shear, and combined tension and shear, as applicable. See steel design information for common threaded rod elements.
- The tabulated seismic values for steel strength of the inserts are applicable to installations in the lower flute or upper flute of the indicated steel deck figures, as applicable..

Idealization of Concrete Filled Steel Decks for Determination of Concrete Breakout Strength in Accordance with ACI 318

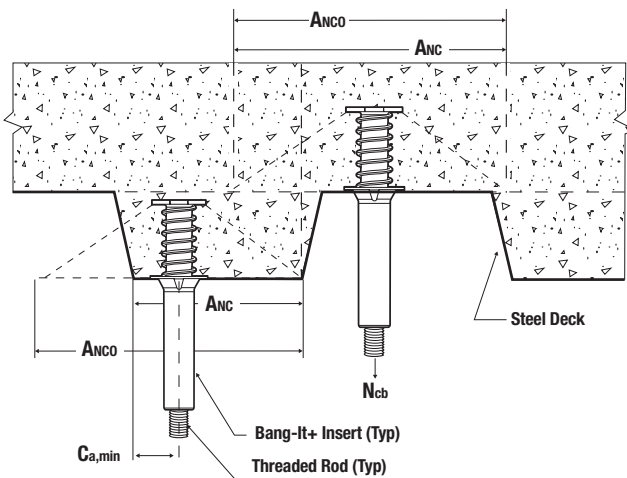

Idealization of Standard 'W' Steel Deck Profiles

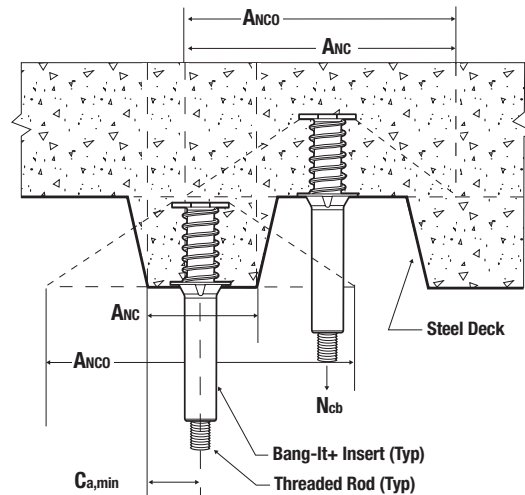

Idealization of 'B' Steel Deck Profiles

Specifications And Physical Properties Of Common Carbon Steel Threaded Rod Elements¹

Threaded Rod Specification		Units	Min. Specified Ultimate Strength, F_{uts}	Min. Specified Yield Strength 0.2 Percent Offset, F_{ys}	$F_{uts} - F_{ys}$	Elongation Minimum Percent ²	Reduction Of Area Min. Percent	Related Nut Specification ³
Carbon Steel	ASTM A36/A36M or ASTM F1554 Grade 36	psi (MPa)	58,000 (400)	36,000 (248)	1.61	23	40 (50 for A36)	ASTM A194 / A563 Grade A
	ASTM A193/A193M ⁴ Grade B7	psi (MPa)	125,000 (860)	105,000 (720)	1.19	16	50	ASTM A194 / A563 Grade DH

For SI: 1 inch = 25.4 mm, 1 psi = 0.006897 MPa. For pound-inch units: 1 mm = 0.03937 inch, 1 MPa = 145.0 psi.

1. Inserts may be used in conjunction with all grades of continuously threaded carbon steels (all-thread) that comply with code reference standards and that have thread characteristics comparable with ANSI B1.1 UNC Coarse Thread Series.
2. Standard Specification for Carbon Structural Steel.
3. Standard Specification for Alloy-Steel and Stainless Steel Bolting Materials for High Temperature or High Pressure Service and Other Special Purpose Applications.
4. Based on 2-inch (50 mm) gauge length except for ASTM A36/A36M and ASTM A193, which are based on a gauge length of 4d (d_{nom}).
5. Where nuts are applicable, nuts of other grades and style having specified proof load stress greater than the specified grade and style are also suitable.



Steel Design Information For Common Threaded Rod Elements Used With Concrete Inserts^{1,2,3,4}

Design Information		Symbol	Units	1/4-inch	3/8-inch	1/2-inch	5/8-inch	3/4-inch
Threaded rod nominal outside diameter		d_{rod}	in. (mm)	0.250 (6.4)	0.375 (9.5)	0.500 (12.7)	0.625 (15.9)	0.750 (19.1)
Threaded rod effective cross-sectional area		A_{se}	in ² (mm ²)	0.032 (21)	0.078 (50)	0.142 (92)	0.226 (146)	0.335 (216)
Steel strength in tension of threaded rod	ASTM A36 or ASTM F1554, Grade 36	$N_{sa,rod,A36}$	lb (kN)	1,855 (8.2)	4,525 (20.0)	8,235 (36.6)	13,110 (58.3)	19,430 (86.3)
Steel strength in tension of threaded rod, seismic		$N_{sa,rod,eq,A36}$	lb (kN)	1,855 (8.2)	4,525 (20.0)	8,235 (36.6)	13,110 (58.3)	19,430 (86.4)
Steel strength in tension of threaded rod	ASTM A193, Gr. B7	$N_{sa,rod,B7}$	lb (kN)	4,000 (17.7)	9,750 (43.1)	17,750 (78.9)	28,250 (125.7)	41,875 (186.0)
Steel strength in tension of threaded rod, seismic		$N_{sa,rod,eq,B7}$	lb (kN)	4,000 (17.7)	9,750 (43.1)	17,750 (78.9)	28,250 (125.7)	41,875 (186.0)
Reduction factor, steel strength in tension		ϕ	-	0.75				
Steel strength in shear of threaded	ASTM A36 or ASTM F1554, Grade 36	$V_{sa,rod,A36}$	lb (kN)	1,115 (4.9)	2,715 (12.1)	4,940 (22.0)	7,865 (35.0)	11,660 (51.9)
Steel strength in shear of threaded rod, seismic		$V_{sa,rod,eq,A36}$	lb (kN)	780 (3.5)	1,900 (8.4)	3,460 (15.4)	5,505 (24.5)	8,160 (36.3)
Steel strength in shear of threaded rod	ASTM A193, Gr. B7	$V_{sa,rod,B7}$	lb (kN)	2,385 (10.6)	5,815 (25.9)	10,640 (47.3)	16,950 (75.4)	25,085 (111.6)
Steel strength in shear of threaded rod, seismic		$V_{sa,rod,eq,B7}$	lb (kN)	1,680 (7.5)	4,095 (18.2)	7,455 (33.2)	11,865 (52.8)	17,590 (78.2)
Reduction factor, steel strength in tension		ϕ	-	0.65				

For SI: 1 inch = 25.4 mm, 1 pound = 0.00445 kN, 1 in² = 645.2 mm². For pound-inch unit: 1 mm = 0.03937 inches.

1. Values provided for steel element material types based on minimum specified strengths and calculated in accordance with ACI 318-11 Eq. (D-2) and Eq. (D-29).
2. ϕN_{sa} shall be the lower of the $\phi N_{sa,rod}$ or $\phi N_{sa,insert}$ for static steel strength in tension; for seismic loading $\phi N_{sa,eq}$ shall be the lower of the $\phi N_{sa,rod,eq}$ or $\phi N_{sa,insert,eq}$.
3. ϕV_{sa} shall be the lower of the $\phi V_{sa,rod}$ or $\phi V_{sa,insert}$ for static steel strength in tension; for seismic loading $\phi V_{sa,eq}$ shall be the lower of the $\phi V_{sa,rod,eq}$ or $\phi V_{sa,insert,eq}$.
4. Strength reduction factors shall be taken from ACI 318-19 17.5.3, ACI 318-14 17.3.3 or ACI 318-11 D.4.3 for steel elements. Condition B is assumed. Strength reduction factors for load combinations in accordance with ACI 318 (-19 or -14) Section 5.3 or ACI 318-11 Section 9.2 governed by steel strength of the threaded rod are taken as 0.75 for tension and 0.65 for shear; values correspond to ductile steel elements. The value of ϕ applies when the load combinations of IBC Section 1605.2, ACI 318 (-19 or -14) Section 5.3 or ACI 318-11 Section 9.2 are used in accordance with ACI 318-19 17.5.3, ACI 318-14 17.3.3 or ACI 318-11 D.4.3. If the load combinations of ACI 318-11 Appendix C are used, then the appropriate value of ϕ must be determined in accordance with ACI 318-11 D.4.4.

DESIGN STRENGTH TABLES (SD)

Tension and Shear Design Strengths for Bang-It+ Single Thread Inserts Installed in the Soffit of Uncracked Concrete Filled Steel Deck Floor and Roof Assemblies^{1,2,3,4,5}



Nominal Anchor Diameter (in.)	Embed. Depth h_{ef} (in.)	Minimum Concrete Compressive Strength											
		$f'_c = 3,000$ psi											
		4-1/2" W-Deck (Figure A)				B-Deck (Figure B)				3-7/8" W-Deck (Figure C)			
		Upper Flute		Lower Flute		Upper Flute		Lower Flute		Upper Flute		Lower Flute	
ϕN_n Tension (lbs.)	ϕV_n Shear (lbs.)	ϕN_n Tension (lbs.)	ϕV_n Shear (lbs.)	ϕN_n Tension (lbs.)	ϕV_n Shear (lbs.)	ϕN_n Tension (lbs.)	ϕV_n Shear (lbs.)	ϕN_n Tension (lbs.)	ϕV_n Shear (lbs.)	ϕN_n Tension (lbs.)	ϕV_n Shear (lbs.)	ϕN_n Tension (lbs.)	ϕV_n Shear (lbs.)
1/4	1-3/4	2,665	1,370	1,340	1,370	2,265	1,250	595	1,250	2,265	1,250	1,145	1,250
3/8	1-3/4	2,665	1,370	1,340	1,370	2,265	1,250	595	1,250	2,265	1,250	1,145	1,250
1/2	1-3/4	2,665	1,370	1,340	1,370	2,265	1,250	595	1,250	2,265	1,250	1,145	1,250
5/8	1-3/4	2,665	1,845	1,340	1,845	2,265	1,785	595	1,785	2,265	1,785	1,145	1,785
3/4	1-3/4	2,665	1,845	1,340	1,845	2,265	1,785	595	1,785	2,265	1,785	1,145	1,785

 - Anchor Pullout/Pryout Strength Controls
 - Concrete Breakout Strength Controls
 - Steel Strength Controls

Tension and Shear Design Strengths for Bang-It+ Single Thread Inserts Installed in the Soffit of Cracked Concrete Filled Steel Deck Floor and Roof Assemblies^{1,2,3,4,5,6}



Nominal Anchor Diameter (in.)	Embed. Depth h_{ef} (in.)	Minimum Concrete Compressive Strength											
		$f'_c = 3,000$ psi											
		4-1/2" W-Deck (Figure A)				B-Deck (Figure B)				3-7/8" W-Deck (Figure C)			
		Upper Flute		Lower Flute		Upper Flute		Lower Flute		Upper Flute		Lower Flute	
ϕN_n Tension (lbs.)	ϕV_n Shear (lbs.)	ϕN_n Tension (lbs.)	ϕV_n Shear (lbs.)	ϕN_n Tension (lbs.)	ϕV_n Shear (lbs.)	ϕN_n Tension (lbs.)	ϕV_n Shear (lbs.)	ϕN_n Tension (lbs.)	ϕV_n Shear (lbs.)	ϕN_n Tension (lbs.)	ϕV_n Shear (lbs.)	ϕN_n Tension (lbs.)	ϕV_n Shear (lbs.)
1/4	1-3/4	1,810	1,370	1,070	1,370	1,810	1,250	475	1,250	1,810	1,250	915	1,250
3/8	1-3/4	1,810	1,370	1,070	1,370	1,810	1,250	475	1,250	1,810	1,250	915	1,250
1/2	1-3/4	1,810	1,370	1,070	1,370	1,810	1,250	475	1,250	1,810	1,250	915	1,250
5/8	1-3/4	1,810	1,845	1,070	1,845	1,810	1,785	475	1,785	1,810	1,785	915	1,785
3/4	1-3/4	1,810	1,845	1,070	1,845	1,810	1,785	475	1,785	1,810	1,785	915	1,785

 - Anchor Pullout/Pryout Strength Controls
 - Concrete Breakout Strength Controls
 - Steel Strength Controls

- Tabular values are provided for illustration and are applicable for single anchors installed in sand-lightweight concrete with minimum slab thickness, $h_a = h_{min}$, and with the following conditions:
 - No edge distance influence with $\Psi_{ed,N} = 1.0$ in tension for upper flute anchors.
 - No edge distance ($c_{a1} \geq 3h_{ef}$) or corner distance influence ($c_{a2} \geq 1.5c_{a1}$) for upper flute anchors in shear. Shear loads may be applied in any direction.
- Calculations were performed following methodology in ACI 318 (19 or -14) Chapter 17 or ACI 318-11 Appendix D. The load level corresponding to the failure mode listed [steel strength of insert ($N_{sa,insert}$, $V_{sa,insert}$), concrete breakout strength, or pryout strength] must be checked against the tabulated steel strength of the corresponding threaded rod type, ($N_{sa,rod}$, $V_{sa,rod}$), the lowest load level controls.
- Strength reduction factors shall be taken from ACI 318-19 17.5.3, ACI 318-14 17.3.3 or ACI 318-11 D.4.3 for cast-in headed anchors. Condition B is assumed. Strength reduction factors for load combinations in accordance with ACI 318 (19 or -14) Section 5.3 or ACI 318-11 Section 9.2 governed by steel strength of the insert are taken as 0.65 for tension and 0.60 for shear; values correspond to brittle steel elements. Tabular values are permitted for short-term static loads only, seismic loading is not considered with these tables.
- For designs that include combined tension and shear, the interaction of tension and shear loads must be calculated in accordance with ACI 318 (19 or -14) Chapter 17 or ACI 318-11 Appendix D.
- Interpolation is not permitted to be used with the tabular values. For intermediate base material compressive strengths please see ACI 318 (19 or -14) Chapter 17 or ACI 318-11 Appendix D and information contained in this product supplement. For other design conditions including seismic considerations please see ACI 318 (19 or -14) Chapter 17 or ACI 318-11 Appendix D.
- For seismic design in accordance with ACI 318, the tabulated tension design strengths for concrete breakout and pullout must be multiplied by a factor of 0.75.

MECHANICAL ANCHORS

BANG-IT+[®]
Concrete Inserts

Tension and Shear Design Strengths Installed for Bang-It+ Multi Thread Inserts Installed in the Soffit of Uncracked Concrete Filled Steel Deck Floor and Roof Assemblies^{1,2,3,4,5}



Nominal Anchor Diameter (in.)	Embed. Depth hef (in.)	Minimum Concrete Compressive Strength											
		f'c = 3,000 psi											
		4-1/2" W-Deck (Figure A)				B-Deck (Figure B)				3-7/8" W-Deck (Figure C)			
		Upper Flute		Lower Flute		Upper Flute		Lower Flute		Upper Flute		Lower Flute	
ΦNn Tension (lbs.)	ΦVn Shear (lbs.)	ΦNn Tension (lbs.)	ΦVn Shear (lbs.)	ΦNn Tension (lbs.)	ΦVn Shear (lbs.)	ΦNn Tension (lbs.)	ΦVn Shear (lbs.)	ΦNn Tension (lbs.)	ΦVn Shear (lbs.)	ΦNn Tension (lbs.)	ΦVn Shear (lbs.)		
1/4" (1/4 - 3/8" Multi)	1-3/4	1,275	1,000	1,275	700	1,275	1,000	595	700	1,275	1,000	1,145	700
3/8" (1/4 - 3/8" Multi)	1-3/4	2,265	1,370	1,340	1,370	2,265	1,370	595	1,250	2,265	1,370	1,145	1,250
3/8" (3/8 - 1/2" Multi)	1-3/4	2,265	1,425	1,340	1,250	2,265	1,425	595	1,250	2,265	1,425	1,145	1,250
1/2" (3/8 - 1/2" Multi)	1-3/4	2,265	2,500	1,340	1,370	2,265	2,500	595	1,250	2,265	2,500	1,145	1,250
1/4" (1/4 - 3/8 - 1/2" Multi)	1-3/4	2,265	1,000	1,340	765	2,265	1,000	595	765	2,265	1,000	1,145	765
3/8" (1/4 - 3/8 - 1/2" Multi)	1-3/4	2,265	2,125	1,340	1,240	2,265	2,125	595	860	2,265	2,125	1,145	860
1/2" (1/4 - 3/8 - 1/2" Multi)	1-3/4	2,265	2,500	1,340	1,240	2,265	2,500	595	1,075	2,265	2,500	1,145	1,075
3/8" (3/8 - 1/2 - 5/8" Multi)	2-1/4	3,300	2,925	1,760	1,510	3,300	1,305	655	1,305	3,300	2,925	1,450	1,305
1/2" (3/8 - 1/2 - 5/8" Multi)	2-1/4	3,300	4,855	1,760	1,510	3,300	1,305	655	1,305	3,300	4,855	1,450	1,305
5/8" (3/8 - 1/2 - 5/8" Multi)	2-1/4	3,300	4,855	1,760	1,510	3,300	1,305	655	1,305	3,300	4,855	1,450	1,305
5/8" (5/8 - 3/4" Multi)	2-1/4	3,300	3,370	1,760	1,825	3,300	1,145	655	1,145	3,300	3,370	1,450	1,145
3/4" (5/8 - 3/4" Multi)	2-1/4	3,300	3,885	1,760	1,825	3,300	1,145	655	1,145	3,300	3,885	1,450	1,145

■ - Anchor Pullout/Pryout Strength Controls ■ - Concrete Breakout Strength Controls ■ - Steel Strength Controls

Tension and Shear Design Strengths Installed for Bang-It+ Multi Thread Inserts Installed in the Soffit of Cracked Concrete Filled Steel Deck Floor and Roof Assemblies^{1,2,3,4,5,6}



Nominal Anchor Diameter (in.)	Embed. Depth hef (in.)	Minimum Concrete Compressive Strength											
		f'c = 3,000 psi											
		4-1/2" W-Deck (Figure A)				B-Deck (Figure B)				3-7/8" W-Deck (Figure C)			
		Upper Flute		Lower Flute		Upper Flute		Lower Flute		Upper Flute		Lower Flute	
ΦNn Tension (lbs.)	ΦVn Shear (lbs.)	ΦNn Tension (lbs.)	ΦVn Shear (lbs.)	ΦNn Tension (lbs.)	ΦVn Shear (lbs.)	ΦNn Tension (lbs.)	ΦVn Shear (lbs.)	ΦNn Tension (lbs.)	ΦVn Shear (lbs.)	ΦNn Tension (lbs.)	ΦVn Shear (lbs.)		
1/4" (1/4 - 3/8" Multi)	1-3/4	1,275	1,000	1,070	700	1,275	1,000	475	700	1,275	1,000	915	700
3/8" (1/4 - 3/8" Multi)	1-3/4	1,810	1,370	1,070	1,370	1,810	1,370	475	1,250	1,810	1,370	915	1,250
3/8" (3/8 - 1/2" Multi)	1-3/4	1,810	1,425	1,070	1,250	1,810	1,425	475	1,250	1,810	1,425	915	1,250
1/2" (3/8 - 1/2" Multi)	1-3/4	1,810	2,500	1,070	1,370	1,810	2,500	475	1,250	1,810	2,500	915	1,250
1/4" (1/4 - 3/8 - 1/2" Multi)	1-3/4	1,810	1,000	1,070	765	1,810	1,000	475	765	1,810	1,000	915	765
3/8" (1/4 - 3/8 - 1/2" Multi)	1-3/4	1,810	2,125	1,070	1,240	1,810	2,125	475	860	1,810	2,125	915	860
1/2" (1/4 - 3/8 - 1/2" Multi)	1-3/4	1,810	2,500	1,070	1,240	1,810	2,500	475	1,075	1,810	2,500	915	1,075
3/8" (3/8 - 1/2 - 5/8" Multi)	2-1/4	2,640	2,925	1,410	1,510	2,640	1,305	525	1,305	2,640	2,925	1,160	1,305
1/2" (3/8 - 1/2 - 5/8" Multi)	2-1/4	2,640	4,855	1,410	1,510	2,640	1,305	525	1,305	2,640	4,855	1,160	1,305
5/8" (3/8 - 1/2 - 5/8" Multi)	2-1/4	2,640	4,855	1,410	1,510	2,640	1,305	525	1,305	2,640	4,855	1,160	1,305
5/8" (5/8 - 3/4" Multi)	2-1/4	2,640	3,370	1,410	1,825	2,640	1,145	525	1,145	2,640	3,370	1,160	1,145
3/4" (5/8 - 3/4" Multi)	2-1/4	2,640	3,885	1,410	1,825	2,640	1,145	525	1,145	2,640	3,885	1,160	1,145

■ - Anchor Pullout/Pryout Strength Controls ■ - Concrete Breakout Strength Controls ■ - Steel Strength Controls

- Tabular values are provided for illustration and are applicable for single anchors installed in sand-lightweight concrete with minimum slab thickness, $h_a = h_{min}$, and with the following conditions:
 - No edge distance influence with $\Psi_{ed,N} = 1.0$ in tension for upper flute anchors.
 - No edge distance ($C_{a1} \geq 3h_a$) or corner distance influence ($C_{a2} \geq 1.5C_{a1}$) for upper flute anchors in shear. Shear loads may be applied in any direction.
- Calculations were performed following methodology in ACI 318 (19 or -14) Chapter 17 or ACI 318-11 Appendix D. The load level corresponding to the failure mode listed [steel strength of insert ($N_{sa,insert}$, $V_{sa,insert}$), concrete breakout strength, or pryout strength] must be checked against the tabulated steel strength of the corresponding threaded rod type, ($N_{sa,rod}$, $V_{sa,rod}$), the lowest load level controls.
- Strength reduction factors shall be taken from ACI 318-19 17.5.3, ACI 318-14 17.3.3 or ACI 318-11 D.4.3 for cast-in headed anchors. Condition B is assumed. Strength reduction factors for load combinations in accordance with ACI 318 (19 or -14) Section 5.3 or ACI 318-11 Section 9.2 governed by steel strength of the insert are taken as 0.65 for tension and 0.60 for shear; values correspond to brittle steel elements. Tabular values are permitted for short-term static loads only, seismic loading is not considered with these tables.
- For designs that include combined tension and shear, the interaction of tension and shear loads must be calculated in accordance with ACI 318 (19 or -14) Chapter 17 or ACI 318-11 Appendix D.
- Interpolation is not permitted to be used with the tabular values. For intermediate base material compressive strengths please see ACI 318 (19 or -14) Chapter 17 or ACI 318-11 Appendix D and information contained in this product supplement. For other design conditions including seismic considerations please see ACI 318 (19 or -14) Chapter 17 or ACI 318-11 Appendix D.
- For seismic design in accordance with ACI 318, the tabulated tension design strengths for concrete breakout and pullout must be multiplied by a factor of 0.75.

Tension and Shear Design Strengths Installed for Bang-It+ Push-In Thread Inserts Installed in the Soffit of Uncracked Concrete Filled Steel Deck Floor and Roof Assemblies^{1,2,3,4,5}



Nominal Anchor Diameter (in.)	Embed. Depth hef (in.)	Minimum Concrete Compressive Strength											
		f'c = 3,000 psi											
		4-1/2" W-Deck (Figure A)				B-Deck (Figure B)				3-7/8" W-Deck (Figure C)			
		Upper Flute		Lower Flute		Upper Flute		Lower Flute		Upper Flute		Lower Flute	
		φNn Tension (lbs.)	φNn Shear (lbs.)	φNn Tension (lbs.)	φNn Shear (lbs.)	φNn Tension (lbs.)	φNn Shear (lbs.)	φNn Tension (lbs.)	φNn Shear (lbs.)	φNn Tension (lbs.)	φNn Shear (lbs.)	φNn Tension (lbs.)	φNn Shear (lbs.)
Push-In 3/8"	1.50	1,795	1,985	1,145	1,375	1,795	1,375	560	1,375	1,795	1,985	960	1,375
Push-In 1/2"	1.70	2,165	4,140	1,300	1,825	2,165	1,520	585	1,520	2,165	4,140	1,105	1,520

■ - Anchor Pullout/Pryout Strength Controls
 ■ - Concrete Breakout Strength Controls
 ■ - Steel Strength Controls

Tension and Shear Design Strengths Installed for Bang-It+ Push-In Thread Inserts Installed in the Soffit of Cracked Concrete Filled Steel Deck Floor and Roof Assemblies^{1,2,3,4,5,6}



Nominal Anchor Diameter (in.)	Embed. Depth hef (in.)	Minimum Concrete Compressive Strength											
		f'c = 3,000 psi											
		4-1/2" W-Deck (Figure A)				B-Deck (Figure B)				3-7/8" W-Deck (Figure C)			
		Upper Flute		Lower Flute		Upper Flute		Lower Flute		Upper Flute		Lower Flute	
		φNn Tension (lbs.)	φNn Shear (lbs.)	φNn Tension (lbs.)	φNn Shear (lbs.)	φNn Tension (lbs.)	φNn Shear (lbs.)	φNn Tension (lbs.)	φNn Shear (lbs.)	φNn Tension (lbs.)	φNn Shear (lbs.)	φNn Tension (lbs.)	φNn Shear (lbs.)
Push-In 3/8"	1.50	1,435	1,985	915	1,375	1,435	1,375	445	1,375	1,435	1,985	765	1,375
Push-In 1/2"	1.70	1,735	4,140	1,040	1,825	1,735	1,520	470	1,520	1,735	4,140	885	1,520

■ - Anchor Pullout/Pryout Strength Controls
 ■ - Concrete Breakout Strength Controls
 ■ - Steel Strength Controls

- Tabular values are provided for illustration and are applicable for single anchors installed in sand-lightweight concrete with minimum slab thickness, $h_a = h_{min}$, and with the following conditions:
 - No edge distance influence with $\Psi_{ed,N} = 1.0$ in tension for upper flute anchors.
 - No edge distance ($C_{a1} \geq 3h_{ef}$) or corner distance influence ($C_{a2} \geq 1.5C_{a1}$) for upper flute anchors in shear. Shear loads may be applied in any direction.
- Calculations were performed following methodology in ACI 318 (19 or -14) Chapter 17 or ACI 318-11 Appendix D. The load level corresponding to the failure mode listed [steel strength of insert ($N_{sa,insert}$, $V_{sa,insert}$), concrete breakout strength, or pryout strength] must be checked against the tabulated steel strength of the corresponding threaded rod type, ($N_{sa,rod}$, $V_{sa,rod}$), the lowest load level controls.
- Strength reduction factors shall be taken from ACI 318-19 17.5.3, ACI 318-14 17.3.3 or ACI 318-11 D.4.3 for cast-in headed anchors. Condition B is assumed. Strength reduction factors for load combinations in accordance with ACI 318 (19 or -14) Section 9.2 governed by steel strength of the insert are taken as 0.65 for tension and 0.60 for shear; values correspond to brittle steel elements. Tabular values are permitted for short-term static loads only, seismic loading is not considered with these tables.
- For designs that include combined tension and shear, the interaction of tension and shear loads must be calculated in accordance with ACI 318 (19 or -14) Chapter 17 or ACI 318-11 Appendix D.
- Interpolation is not permitted to be used with the tabular values. For intermediate base material compressive strengths please see ACI 318 (19 or -14) Chapter 17 or ACI 318-11 Appendix D and information contained in this product supplement. For other design conditions including seismic considerations please see ACI 318 (19 or -14) Chapter 17 or ACI 318-11 Appendix D.
- For seismic design in accordance with ACI 318, the tabulated tension design strengths for concrete breakout and pullout must be multiplied by a factor of 0.75.

Tension and Shear Design Strength of Steel Elements (Steel Strength)^{1,2,3,4}



Nominal Rod Diameter (in.)	Steel Elements - Threaded Rod			
	ASTM A36		ASTM A193 Grade B7	
	φN _{sa,rod} Tension (lbs.)	φN _{sa,rod} Shear (lbs.)	φN _{sa,rod} Tension (lbs.)	φN _{sa,rod} Shear (lbs.)
1/4	1,390	720	3,000	1,550
3/8	3,395	1,750	7,315	3,780
1/2	6,175	3,210	13,315	6,915
5/8	9,835	5,115	21,190	11,020
3/4	14,550	7,565	31,405	16,305

■ - Steel Strength Controls

- Steel tensile design strength according to ACI 318-11 Appendix D and ACI 318 (-19 or -14) Chapter 17, $\phi N_{sa} = \phi \cdot A_{se,N} \cdot f_{uta}$
- The tabulated steel design strength in tension for the threaded rod must be checked against the design strength of the steel insert, concrete breakout and pullout design strength to determine the controlling failure mode, the lowest load level controls.
- Steel shear design strength according to ACI 318-11 Appendix D and ACI 318 (-19 or -14) Chapter 17, $\phi V_{sa} = \phi \cdot 0.60 \cdot A_{se,N} \cdot f_{uta}$
- The tabulated steel design strength in shear for the threaded rod must be checked against the design strength of the steel insert, concrete breakout and pryout design strength to determine the controlling failure mode, the lowest load level controls.

ORDERING INFORMATION

Bang-It® + Steel Deck Insert (UNC internal thread)

Cat. No.	Description	Color Code	Suggested Hole Size in Steel Deck	Pack Qty.
07540-PWR	1/4" Bang-It+	Brown	7/8"	100
07542-PWR	3/8" Bang-It+	Green	7/8"	100
07544-PWR	1/2" Bang-It+	Yellow	7/8"	100
07546-PWR	5/8" Bang-It+	Red	1-1/4"	50
07548-PWR	3/4" Bang-It+	Purple	1-1/4"	50
PFM3521438	1/4-3/8" Bang-It+ Multi	White	7/8"	100
07543-PWR	3/8-1/2" Bang-It+ Multi	Gray	7/8"	100
PFM353143812	1/4-3/8-1/2" Bang-It+ Multi	Aqua	7/8"	50
PFM353381258	3/8-1/2-5/8" Bang-It+ Multi	Orange	1-1/4"	50
PFM3525834	5/8-3/4" Bang-It+ Multi	Black	1-1/4"	50
PFM3610038	3/8" Bang-It+ Push-In	Green	1-1/4"	50
PFM3610012	1/2" Bang-It+ Push-In	Yellow	1-1/4"	50

Inserts are color coded to easily identify location, type and sizes of the internal diameters.



Bang-It® + Installation Accessories and Tools

Cat.No.	Description	Pack Qty.
DCD996P2	20V Max XR Lithium Ion Cordless Drill Driver Kit (5.0Ah)	1
PFM3611000	Bang-It+ Deck Driller Extension 28" (Use with 1/2" Drill Driver)	1
1779804	5L Arbor, 3/8" Solid Hex Shank	1
1779801	2L Arbor, 1/2" Solid Hex Shank	1
2009314CHC	Carbide Hole Cutter Bit 7/8" (use 5L Arbor, not included)	1
2009820CHC	Carbide Hole Cutter Bit 1-1/4" (use 2L Arbor, not included)	1
30912VB12	Vari-Bit Step Drill Bit 7/8", 1-1/8", 1-7/32", 1-1/4", 1-3/8"	1
PFM3613000	Bang-It+ Bridge Bar	20
PFM3613001	Bang-It+ Bridge Bar (packaged with screws)	20

Bang-It+ Bridge Bar nominal size is 2" wide x 12" long, 14 gauge thickness.



Push-In Thread Couplers

Cat. No.	Description	Pack Qty.
PFM3613038	3/8"-16 Coupler Push-In	20
PFM3613012	1/2"-13 Coupler Push-In	20

Push-In thread couplers have one end that does not require turning threaded rod elements during installation which can be ideal for applications such as mounting prefabricated hardware and hanger assemblies.

