

ICC-ES Evaluation Report

ESR-3958

Reissued December 2024

This report also contains:



- [City of LA Supplement](#)

Subject to renewal December 2025

- [FL Supplement w/ HVHZ](#)

ICC-ES Evaluation Reports are not to be construed as representing aesthetics or any other attributes not specifically addressed, nor are they to be construed as an endorsement of the subject of the report or a recommendation for its use. There is no warranty by ICC Evaluation Service, LLC, express or implied, as to any finding or other matter in this report, or as to any product covered by the report.

Copyright © 2024 ICC Evaluation Service, LLC. All rights reserved.

<p>DIVISION: 03 00 00— CONCRETE</p> <p>Section: 03 15 19—Cast- In Concrete Anchors</p> <p>Section: 03 16 00— Concrete Anchors</p>	<p>REPORT HOLDER: DEWALT</p> 	<p>EVALUATION SUBJECT:</p> <p>DDI+™ HEADED CAST- IN SPECIALTY INSERTS FOR CRACKED AND UNCRACKED CONCRETE-FILLED STEEL DECKS (DEWALT)</p>	
--	--	--	---

1.0 EVALUATION SCOPE

Compliance with the following codes:

- 2024, 2021, 2018, and 2015 [International Building Code® \(IBC\)](#)
- 2024, 2021, 2018, and 2015 [International Residential Code® \(IRC\)](#)

Main references of this report are for the 2024 IBC and IRC. See [Table 3](#) and [Table 4](#) for applicable sections of the code for previous IBC and IRC editions.

Property evaluated:

- Structural

2.0 USES

The DEWALT DDI+ inserts are headed cast-in specialty inserts cast in concrete filled metal deck used as anchorage in the soffit of cracked and uncracked normal-weight concrete and sand-lightweight concrete on steel deck having a specified compressive strength, f'_c , of 3,000 psi to 10,000 psi (20.7 MPa to 68.9 MPa) to resist static, wind, and seismic tension and shear loads.

There are three models for the DDI+ inserts evaluated in this report; $\frac{3}{8}$ -inch, $\frac{1}{2}$ -inch, and $\frac{5}{8}$ -inch, corresponding to the sizes of the threaded bolts used in the inserts.

The inserts are alternatives to cast-in anchors described in Section 1901.3 of the 2024 IBC. The inserts may be used where an engineered design is submitted in accordance with Section R301.1.3 of the IRC.

3.0 DESCRIPTION

3.1 DDI+ Inserts:

The DDI+ steel deck inserts are cast-in concrete inserts. The insert consists of an internally threaded steel base plate and a threaded bolt. The insert is illustrated in [Figures 1A](#) and [1B](#). The steel plates are manufactured from low carbon steel. The threaded bolts comply with the geometrical requirements of ACI 318-19 for cast-in headed bolts, are manufactured from carbon steel, and have a minimum 5 μ m (0.002-inch) zinc plating.

The DDI+ insert is installed through a predrilled hole in the topside of the metal deck. The insert can optionally be attached to the metal deck using pre-mounted self-drilling screws on the steel plate. Concrete can then be cast over the insert.

3.2 Concrete:

Normal-weight, sand-lightweight, and all-lightweight concrete must conform to Sections 1903 and 1905 of the 2024 IBC.

3.3 Steel Deck Panels:

Steel deck panels must be in accordance with the configuration in [Figures 3A, 3B](#) and [3C](#) and have a minimum base steel thickness of 20 gage [0.034 inch (0.864 mm)]. Steel must comply with ASTM A653/A653M SS Grade 50 minimum and have a minimum yield strength of 50,000 psi (345 MPa).

4.0 DESIGN AND INSTALLATION

4.1 Strength Design:

4.1.1 General: Design strength of anchors complying with the 2024 IBC as well as Section R301.1.3 of the 2024 IRC must be determined in accordance with ACI 318-19 Chapter 17 and this report.

Design parameters provided in [Tables 1](#) and [2](#) of this report are based on the 2024 IBC (ACI 318-19), unless noted otherwise in Sections 4.1.1 through 4.1.12. The strength design of anchors must comply with ACI 318-19 Section 17.5.1.2, except as required in ACI 318-19 Section 17.10.

Strength reduction factors, ϕ , as given in ACI 318-19 Section 17.5.3, for cast-in headed anchors, must be used for load combinations calculated in accordance with Section 1605.1 of the 2024 IBC, and Section 5.3 of ACI 318-19. The value of f'_c used in the calculations must be limited to a maximum of 10,000 psi (68.9 MPa), in accordance with ACI 318-19 Section 17.3.1.

4.1.2 Requirements for Static Steel Strength in Tension: The nominal static steel strength in tension, N_{sa} , of a single anchor must be calculated in accordance with ACI 318-19 Section 17.6.1. $N_{sa,insert}$ provided in [Table 2](#) must be used as the steel strength in tension.

4.1.3 Requirements for Static Concrete Breakout Strength in Tension: For the DDI+ insert, the nominal concrete breakout strength of a single anchor or group of anchors in tension, N_{cb} or N_{cbg} , respectively, must be calculated in accordance with ACI 318-19 Section 17.6.2, for cast-in headed bolts, with modifications as described in this section, and with [Figures 3A, 3B, 3C](#), and [4](#) of this report, as applicable. The basic concrete breakout strength in tension, N_b , must be calculated in accordance with ACI 318-19 Section 17.6.2.2, using the values of h_{ef} given in [Table 2](#), and with $k_c = 24$. The nominal concrete breakout strength in tension in regions where analysis indicates no cracking in accordance with ACI 318-19 Section 17.6.2.5 must be calculated with $\Psi_{c,N} = 1.25$. For the DDI+ inserts installed in the soffit of sand-lightweight or normal-weight concrete filled steel deck assemblies, the contribution of the steel deck strength must be ignored and the calculation of A_{Nc} / A_{Nco} in accordance with ACI 318-19 Section 17.6.2.1 and $C_{a,min}$ (minimum edge distance) must be based on [Figures 3C](#) and [4](#), as applicable.

4.1.4 Requirements for Static Side-Face Blowout Strength in Tension: For the DDI+ inserts installed in the soffit of sand-lightweight or normal-weight concrete on steel deck floor and roof assemblies as shown in [Figures 3A, 3B](#) and [3C](#), calculation of the concrete side blowout strength is not required.

4.1.5 Requirements for Static Pullout Strength in Tension: The pullout strength of a single anchor or a group of anchors, shall be calculated in accordance with ACI 318-19 Section 17.6.3 in cracked and uncracked concrete, $N_{p,cr}$ and $N_{p,uncl}$.

4.1.6 Requirements for Static Steel Strength in Shear: For the DDI+ inserts, the nominal static steel strength in shear, $V_{sa,deck}$, of a single insert, in concrete filled steel deck assemblies, must be taken as the insert strength, $V_{sa,insert}$ in [Table 2](#), and must be used in lieu of the values derived by calculation from ACI 318-19 Eq. 17.7.1.2a or 17.7.1.2b.

4.1.7 Requirements for Static Concrete Breakout Strength in Shear: For the DDI+ inserts installed in the soffit of sand-lightweight or normal-weight concrete on steel deck floor and roof assemblies, as shown in [Figures 3A, 3B](#) and [3C](#), the breakout strength in shear need not be calculated.

4.1.8 Requirements for Static Concrete Pryout Strength in Shear: For the DDI+ inserts installed in the soffit of sand-lightweight or normal-weight concrete filled steel deck assemblies, as shown in [Figures 3A, 3B](#) and [3C](#), calculation of the concrete pry-out strength in accordance with ACI 318-19 Section 17.7.3 is not required.

4.1.9 Requirements for Seismic Design:

4.1.9.1 General: For load combinations including seismic, the design must be performed in accordance with ACI 318-19 Section 17.10. Modifications to ACI 318-19 Section 17.10 shall be applied under Section 1905.7 of the 2024 IBC. The anchors may be installed in Seismic Design Categories A through F of the IBC.

For DDI+ inserts, the nominal concrete breakout strength for anchors in tension; and the nominal concrete breakout strength in the upper flute of concrete filled steel deck assemblies for anchors in shear, must be calculated in accordance with ACI 318-19 Sections 17.6 and 17.7.

4.1.9.2 Seismic Tension: For DDI+ inserts, the nominal steel strength in tension, N_{sa} , of a single anchor must be calculated in accordance with ACI 318-19 Section 17.6.1 for the insert using the values of $N_{sa,insert,eq}$ in [Table 2](#) of this report; the nominal concrete breakout strength for anchors in tension must be calculated in accordance with ACI 318-19 Section 17.6.2, as described in Section 4.1.3 of this report; and the nominal concrete pullout strength must be calculated in accordance with ACI 318-19 Sections 17.6.3.1 and 17.6.3.2., and as described in Section 4.1.5 of this report, as applicable.

4.1.9.3 Seismic Shear: For DDI+ inserts, the nominal concrete breakout strength and pryout strength in shear, calculations in accordance with ACI 318-19 Sections 17.7.2 and 17.7.3, as described in Sections 4.1.7 and 4.1.8 of this report, are not required. In accordance with ACI 318-19 Section 17.7.1.2, the nominal steel strength for seismic loads, $V_{sa,eq}$, must be taken as the insert strength, $V_{sa,insert,deck,eq}$, given in [Table 2](#) of this report.

4.1.10 Requirements for Interaction of Tensile and Shear Forces: For designs that include combined tension and shear, the interaction of tension and shear loads must be calculated in accordance with ACI 318-19 Section 19.7.8.

Due to the projection of DDI+ inserts when installed in the inclined section of concrete filled steel deck assemblies, for anchors or groups of anchors that are subject to the effects of combined tension and shear forces, the design engineer must verify the validity of the interaction equation in ACI 318-19 Section 17.8.

4.1.11 Requirements for Minimum Member Thickness, Minimum Anchor Spacing and Minimum Edge Distance: For DDI+ inserts installed in the soffit of sand-lightweight or normal-weight concrete over profile steel deck floor and roof assemblies, the anchors must be installed in accordance with [Figures 3A, 3B](#) and [3C](#) and shall have a minimum axial spacing along the flute in accordance with [Table 1](#).

4.1.12 Requirements for Critical Edge Distance: The critical edge distance, c_{ac} , must be calculated in accordance with ACI 318-19 Section 17.9.2. The modification factor $\psi_{cp,N} = 1.0$ in accordance with ACI 318-19 Section 17.6.2.6.

4.1.13 Sand-lightweight Concrete: For DDI+ inserts in the soffit of sand-lightweight concrete-filled steel deck, λ shall be taken as 0.85 and applied to the concrete breakout strength in tension, as applicable.

4.2 Allowable Stress Design (ASD):

4.2.1 General: Design values for use with allowable stress design (working stress design) load combinations calculated in accordance with Section 1605.1 of the 2024 IBC must be established as follows:

$$T_{allowable,ASD} = \frac{\phi N_n}{\alpha}$$

$$V_{allowable,ASD} = \frac{\phi V_n}{\alpha}$$

where:

$T_{allowable,ASD}$ = Allowable tension load (lbf or kN).

$V_{allowable,ASD}$ = Allowable shear load (lbf or kN).

ϕN_n = Lowest design strength of an anchor or anchor group in tension as determined in accordance with ACI 318-19 Chapter 17 and 2024 IBC Section 1905.7 (lbf or N).

ϕV_n = Lowest design strength of an anchor or anchor group in shear as determined in accordance with ACI 318-19 Chapter 17 and 2024 IBC Section 1905.7 (lbf or N).

α = Conversion factor calculated as a weighted average of the load factors for the controlling load combination. In addition, α must include all applicable factors to account for non-ductile failure modes and required over-strength.

The requirements for member thickness, edge distance and spacing, described in this report, must apply.

4.2.2 Interaction of Tensile and Shear Forces: For designs that include combined tension and shear, the interaction of tension and shear loads must be calculated in accordance with ACI 318-19 Section 17.8, as follows:

For shear loads $V_{applied} \leq 0.2V_{allowable,ASD}$, the full allowable load in tension must be permitted.

For tension loads $T_{applied} \leq 0.2T_{allowable,ASD}$, the full allowable load in shear must be permitted.

For all other cases:

$$\frac{T_{applied}}{T_{allowable,ASD}} + \frac{V_{applied}}{V_{allowable,ASD}} \leq 1.2 \quad (\text{Eq-1})$$

Due to the projection of DDI+ inserts when installed in the inclined section of concrete filled steel deck assemblies, for anchors or groups of anchors that are subject to the effects of combined tension and shear forces, the design engineer must verify the validity of the interaction equation in ACI 318-19 Section 17.8.

4.3 Installation:

For the DDI+ inserts, installation parameters are provided in [Table 1](#) and in [Figures 3A, 3B](#) and [3C](#). A hole must be made in the steel deck using a step-drill, hole saw, deck punch or equivalent in accordance with the following hole diameters: $7/16$ -inch or $1/2$ -inch (11 mm or 12 mm) diameter [for DDI+ $3/8$ -inch], $9/16$ -inch or $5/8$ -inch (14 mm to 16 mm) diameter [for DDI+ $1/2$ -inch], and $11/16$ -inch or $3/4$ -inch (17 mm to 19 mm) [for DDI+ $5/8$ -inch]. The insert bolt must be placed in the hole. The insert can optionally be attached to the metal deck using pre-mounted self-drilling screws on the steel plate. Concrete can then be cast over the insert.

Installation of DDI+ inserts must be in accordance with this evaluation report and the manufacturer's printed installation instructions (MPII) as provided in [Figure 1](#) of this report. In the event of a conflict between this report and the MPII, this report governs.

4.4 Special Inspection:

Periodic special inspection is required in accordance with Section 1705.1.1 and Table 1705.3 of the 2024 IBC. The special inspector must make periodic inspections during installation of the cast-in specialty inserts to verify insert type, insert dimensions, concrete type, concrete compressive strength, insert spacing, edge distances, concrete member thickness, insert embedment, and adherence to the manufacturer's printed installation instructions. The special inspector must be present as often as required in accordance with the "statement of special inspection." Under the IBC, additional requirements as set forth in Sections 1705, 1706 and 1707 must be observed, where applicable.

5.0 CONDITIONS OF USE:

The DDI+ headed cast-in specialty inserts in concrete described in this report are acceptable alternatives to what is specified in the codes listed in Section 1.0 of this report, subject to the following conditions:

- 5.1 Specialty insert sizes, dimensions, minimum embedment depths, and other installation parameters are as set forth in this report.
- 5.2 Specialty inserts must be installed in accordance with the manufacturer's printed installation instructions and this report. In case of conflict, this report governs.
- 5.3 Specialty inserts must be limited to use in cracked and uncracked normal-weight or sand-lightweight concrete filled steel deck assemblies having a specified compressive strength, f'_c , of 3,000 psi to 10,000 psi (20.7 MPa to 68.9 MPa) for the DDI+ inserts.
- 5.4 The concrete shall have attained its minimum design strength prior to installation of the anchors.
- 5.5 Strength design values must be established in accordance with Section 4.1 of this report.
- 5.6 Allowable design values are established in accordance with Section 4.2.
- 5.7 Specialty insert spacing and edge distance as well as minimum member thickness must comply with ACI 318-19 Section 17.9 for cast-in-place headed anchors.

- 5.8 Prior to installation, calculations and details demonstrating compliance with this report must be submitted to the code official. The calculations and details must be prepared by a registered design professional where required by the statutes of the jurisdiction in which the project is to be constructed.
- 5.9 Since an ICC-ES acceptance criteria for evaluating data to determine the performance of the specialty inserts subjected to fatigue or shock loading is unavailable at this time, the use of these inserts under such conditions is beyond the scope of this report.
- 5.10 Specialty inserts may be installed in regions of concrete where analysis indicates cracking may occur ($f_t > f_r$), subject to the conditions of this report.
- 5.11 Specialty inserts may be used to resist short-term loading due to wind or seismic forces in locations designated as Seismic Design Categories A through F of the IBC, subject to the conditions of this report.
- 5.12 Where not otherwise prohibited in the code, the inserts are permitted for use with fire-resistance-rated construction provided that at least one of the following conditions is fulfilled:
- Headed cast-in specialty inserts that support a fire-resistance-rated envelope or a fire-resistance-rated membrane are protected by approved fire-resistance-rated materials, or have been evaluated for resistance to fire exposure in accordance with recognized standards.
 - Headed cast-in specialty inserts are used to resist wind or seismic forces only.
 - Headed cast-in specialty inserts are used to support nonstructural elements.
- 5.13 Use of zinc-coated carbon steel anchors is limited to dry, interior locations.
- 5.14 Special inspection must be provided in accordance with Section 4.4.
- 5.15 Specialty inserts are manufactured under an approved quality-control program with inspections by ICC-ES.

6.0 EVIDENCE SUBMITTED

- 6.1 Data in accordance with the [ICC-ES Acceptance Criteria for Headed Cast-in Specialty Inserts in Concrete \(AC446\)](#), dated August 2018 (editorially revised April 2024).
- 6.2 Geometrical documentation of the threaded bolts.
- 6.3 Quality control documentation.

7.0 IDENTIFICATION

- 7.1 The inserts are identified by packaging labeled with the insert size, lot number, company name (DEWALT), and insert name (DDI+) as set forth in Section 3.1 of this report, and evaluation report number (ESR-3958). The inserts have the letters DDI+ and the specific size embossed atop the plate of the insert, visible prior to installation for verification.
- 7.2 The report holder's contact information is the following:

DEWALT
701 EAST JOPPA ROAD
TOWSON, MARYLAND 21286
(800) 524-3244
www.DEWALT.com
anchors@dewalt.com

TABLE A—DESIGN USE AND REPORT TABLE INDEX

DESIGN STRENGTH ¹			DDI+ STEEL DECK INSERTS	
Failure Mode	Tension	Shear		
Steel	N_{sa}	V_{sa}	Table 2	
Concrete	Breakout	N_{cb}, N_{cbg}	Table 2	
		-	Not applicable	
	Side-face Blowout	N_{sb}	-	Not applicable
	Pryout	-	V_{cp}, V_{cpg}	Not applicable
Pullout	N_{pn}	-	ACI 318-19 Section 17.6.3	
CONCRETE TYPE	CONCRETE STATE	INSERT NOMINAL SIZE	SEISMIC DESIGN CATEGORIES ²	
Normal-weight and lightweight	Cracked	$\frac{3}{8}$ " , $\frac{1}{2}$ " , $\frac{5}{8}$ "	A through F	
	Uncracked	$\frac{3}{8}$ " , $\frac{1}{2}$ " , $\frac{5}{8}$ "	A and B	

For SI: 1 inch = 25.4 mm. For pound-inch units: 1 mm = 0.03937 inch.

¹Reference ACI 318-19 Section 17.5.1.3. The controlling strength governs from all appropriate failure modes (i.e., steel, concrete breakout, concrete pryout and side-face blowout, as applicable) and design assumptions. The side-face blowout strength in tension, and the breakout strength and pryout strength in shear, are not decisive for design and do not need to be evaluated.

²See Section 4.1.9 for requirements for seismic design, where applicable.

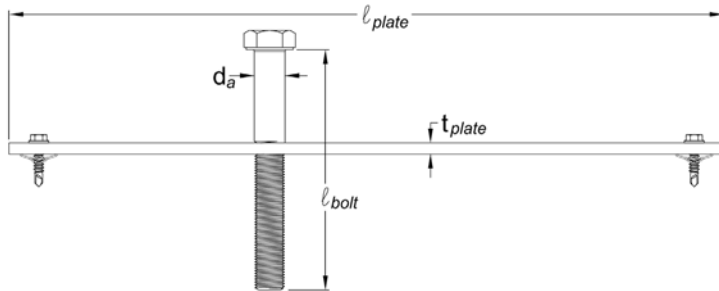

FIGURE 1A—DDI+ INSERT DETAIL



FIGURE 1B—DDI+ DECK INSERT

TABLE 1—DDI+ INSERT INSTALLATION INFORMATION AND SUPPLEMENTAL INFORMATION^{1,2}

CHARACTERISTIC		SYMBOL	UNITS	3/8-inch	1/2-inch	5/8-inch
Nominal bolt diameter		d_a	in. (mm)	0.375 (9.5)	0.500 (12.7)	0.625 (15.9)
Overall length of insert bolt		l_{bolt}	in. (mm)	8 (203)	8 (203)	8 (203)
Nominal overall length of insert plate		l_{plate}	in. (mm)	12 (305)	12 (305)	12 (305)
Nominal width of insert plate		W_{plate}	in. (mm)	1 1/4 (32)	1 1/4 (32)	1 1/4 (32)
Approximate thickness of insert plate		t_{plate}	in. (mm)	3/16 (4.8)	3/16 (4.8)	3/16 (4.8)
Minimum nominal embedment depth ³	Over upper flute	$h_{nom} (upperflute)$	in. (mm)	1 3/4 (45)	2 (51)	2 3/8 (60)
	Over flute incline	$h_{nom} (fluteincline)$				
	Over lower flute	$h_{nom} (lowerflute)$				
Minimum effective embedment depth	Over upper flute	$h_{ef} (upperflute)$	in. (mm)	1.50 (38)	1.75 (45)	2.00 (51)
	Over flute incline	$h_{ef} (fluteincline)$				
	Over lower flute	$h_{ef} (lowerflute)$				
Minimum concrete member thickness (topping thickness)	Over upper flute	$h_{min} (upperflute)$	in. (mm)	2 (51)	2 1/2 (64)	3 1/4 (83)
	Over flute incline	$h_{min} (fluteincline)$				
	Over lower flute	$h_{min} (lowerflute)$				
Minimum flute edge distance (insert bolt)	Over upper flute	$C_{min,deck} (upperflute)$	in. (mm)	Not Applicable	Not Applicable	Not Applicable
	Over flute incline	$C_{min,deck} (fluteincline)$				
	Over lower flute	$C_{min,deck} (lowerflute)$				
Minimum spacing distance (bolt spacing, center-to-center)	Over upper flute	$S_{min} (upperflute)$	in. (mm)	1 1/2 (38)	2 (51)	2 1/2 (64)
	Over flute incline	$S_{min} (fluteincline)$				
	Over lower flute	$S_{min} (lowerflute)$				
Minimum deck end distance	Over upper flute	$C_{min} (upperflute)$	in. (mm)	Specified cover requirements for reinforcement in accordance with ACI 318-19 Section 17.9.2.		
	Over flute incline	$C_{min} (fluteincline)$				
	Over lower flute	$C_{min} (lowerflute)$				
Effective insert bolt tensile stress area		A_{se}	in. ² (mm ²)	0.078 (50)	0.142 (92)	0.226 (146)
Insert bolt head net bearing area		A_{brg}	in ² (mm ²)	0.17 (110)	0.28 (181)	0.45 (290)
Minimum specified ultimate strength		f_{uta}	psi (N/mm ²)	60,000 (400)		
Minimum specified yield strength		f_{ya}	psi (N/mm ²)	36,000 (248)		

For SI: 1 inch = 25.4 mm, 1 ft-lb = 1.356 N-m.

¹The information presented is to be used in conjunction with the design criteria of ACI 318-19 Chapter 17.

²For installation detail for inserts in concrete-filled steel deck assemblies, see Figures 3A, 3B and 3C (i.e. over upper flute, over flute incline, over lower flute).

³Nominal embedment depth is taken from the bottom of the insert plate to the top of the insert bolt.

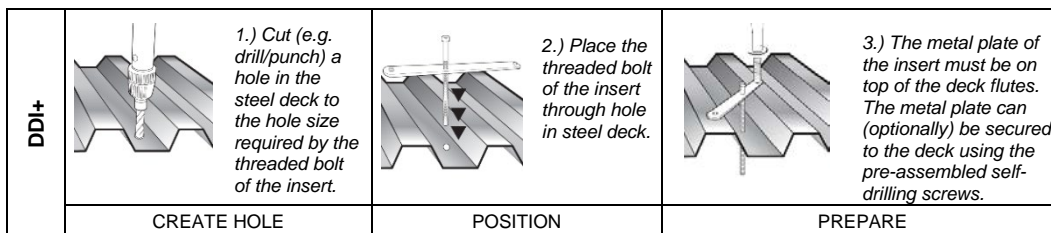

FIGURE 2—DDI+ CONCRETE INSERTS FOR STEEL DECK INSTALLATION INSTRUCTIONS

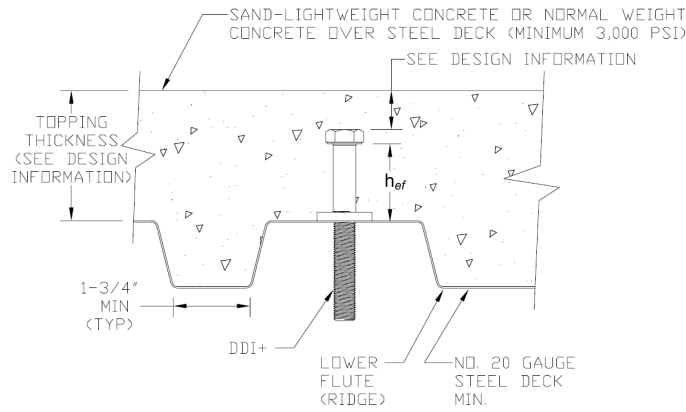

FIGURE 3A—DDI+ CONCRETE INSERTS INSTALLED THROUGH THE SOFFIT OF CONCRETE-FILLED STEEL DECK FLOOR AND ROOF ASSEMBLIES (OVER UPPER FLUTE)^{1,2,3}

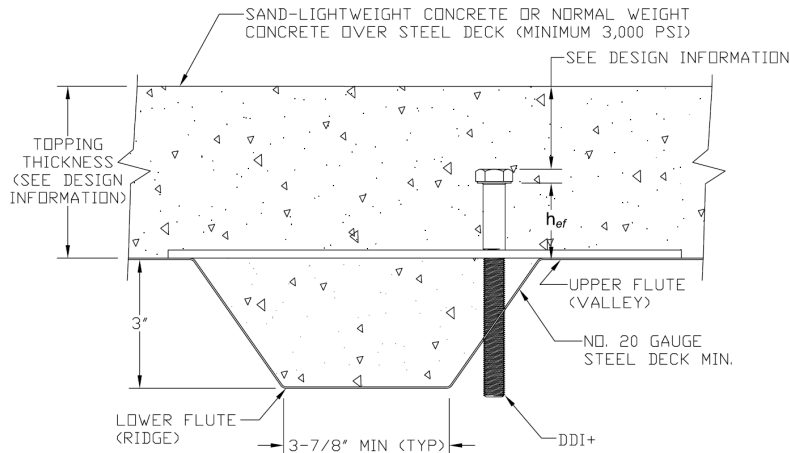

FIGURE 3B—DDI+ CONCRETE INSERTS INSTALLED THROUGH THE SOFFIT OF CONCRETE-FILLED STEEL DECK FLOOR AND ROOF ASSEMBLIES (OVER FLUTE INCLINE)^{1,2,4}

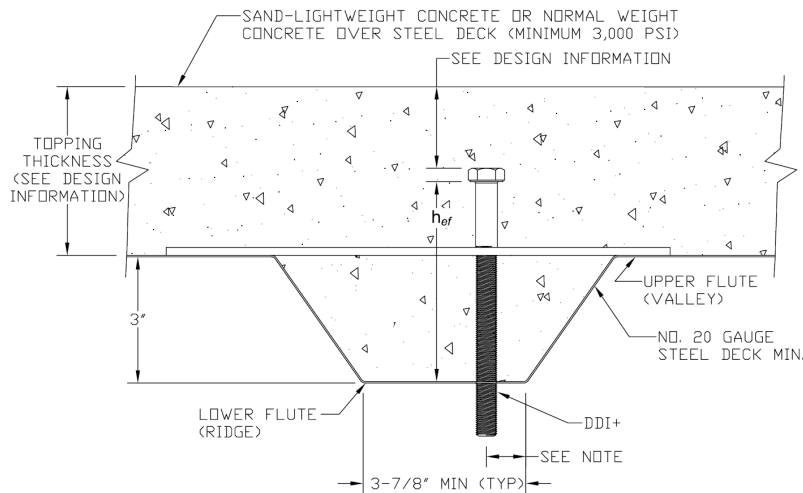

FIGURE 3C—DDI+ CONCRETE INSERTS INSTALLED THROUGH THE SOFFIT OF CONCRETE-FILLED STEEL DECK FLOOR AND ROOF ASSEMBLIES (OVER LOWER FLUTE)^{1,2,5,6}

Footnotes for Figures 3A, 3B, 3C:

- ¹ Installations require a minimum concrete member topping thickness from the top of the upper flute as given in [Table 2](#) of this report.
- ² Inserts may be placed on the upper flute of the steel deck assembly; they may be installed anywhere across upper flute in any orientation as follows:
 - ([Figure 3A](#)) - Placed over the upper flute with threaded bolt installed through the upper flute (with insert plate placed in any orientation or as pictured) or;
 - ([Figure 3B](#)) - Placed over the upper flute spanning the lower flute with threaded bolt installed through the inclined section or;
 - ([Figure 3C](#)) - Placed over the upper flute spanning the lower flute with threaded bolt installed through the lower flute.
- ³ [Figure 3A](#) - Inserts over the upper flute with threaded bolt installed through the upper flute may be placed in any location and orientation that meets the minimum deck end distance requirements (see [Table 2](#)). The minimum deck end distance is measured from deck end to the centerline of the insert bolt.
- ⁴ [Figure 3B](#) - Inserts over the upper flute spanning the lower flute with threaded bolt installed through the inclined section may be placed in any location and orientation that meets the minimum deck end distance requirements (see [Table 2](#)). The minimum deck end distance is measured from deck end to the centerline of the insert bolt. Insert bolts may be placed in locations with minimum lower flute edge distance less than as required in [Figure 3B](#); in these cases values for [Figure 3B](#) can be used.
- ⁵ [Figure 3C](#) - Inserts over the upper flute spanning the lower flute with threaded bolt installed through the lower flute may be placed in any location and orientation that meets the minimum deck end distance and minimum lower flute edge distance requirements. The minimum deck end distance is measured from deck end to the centerline of the insert bolt. The minimum lower flute edge distance is measured from the edge of the lower flute to the centerline of the insert bolt.
- ⁶ [Figure 3C](#) - For lower flute widths of 3⁷/₈-inch, a maximum 1-inch centerline bolt offset in either direction from the center of the flute. The offset distance may be increased for flute widths greater than those shown provided the minimum lower flute edge distance of 1⁵/₁₆-inch is also satisfied.

TABLE 2—DDI+ INSERT DESIGN INFORMATION^{1,2,3,4,5,6}

DESIGN INFORMATION		SYMBOL	UNITS	3/8-inch	1/2-inch	5/8-inch
Insert O.D. (nominal bolt diameter)		d_a	in. (mm)	0.375 (9.5)	0.500 (12.7)	0.625 (15.9)
Insert head net bearing area		A_{brg}	in ² (mm ²)	0.17 (110)	0.28 (181)	0.45 (290)
Effective tensile stress area		A_{se}	in. ² (mm ²)	0.078 (50)	0.142 (92)	0.226 (146)
Effective embedment depth	Over upper flute	$h_{ef} (upperflute)$	in. (mm)	1.50 (38)	1.75 (45)	2.00 (51)
	Over flute incline	$h_{ef} (fluteincline)$				
	Over lower flute	$h_{ef} (lowerflute)$				
Minimum concrete member thickness (topping thickness over upper flute)		h_{min}	in. (mm)	2.00 (51)	2.50 (64)	3.25 (83)
Minimum spacing and edge distance		s_{min}, c_{min}	in. (mm)	See Table 1 and Figures 3A, 3B and 3C		
Effectiveness factor for cracked concrete		k_c	- (SI)	24 (10)		
Modification factor for tension strength in uncracked concrete		$\psi_{C,N}$	-	1.25		
According to Figures 3A, 3B or 3C	Nominal tension strength of single insert as governed by steel strength	$N_{sa,insert}$	lb (kN)	4,650 (20.7)	8,520 (37.9)	13,560 (60.3)
	Nominal tension strength of single insert as governed by steel strength, seismic	$N_{sa,insert,eq}$				
According to Figure 3A (over upper flute)	Nominal steel shear strength of single insert in the soffit of concrete on steel deck	$V_{sa,insert,deck} (upperflute)$	lb (kN)	2,280 (10.1)	4,260 (18.9)	7,245 (32.2)
	Nominal steel shear strength of single insert in the soffit of concrete on steel deck, seismic	$V_{sa,insert,deck,eq} (upperflute)$		1,825 (8.1)	3,410 (15.2)	
According to Figure 3B (over flute incline)	Nominal steel shear strength of single insert in the soffit of concrete on steel deck	$V_{sa,insert,deck} (fluteincline)$	lb (kN)	1,310 (5.8)	3,410 (15.2)	5,240 (23.3)
	Nominal steel shear strength of single insert in the soffit of concrete on steel deck, seismic	$V_{sa,insert,deck,eq} (fluteincline)$		1,045 (4.6)	2,860 (12.7)	
According to Figure 3C (over lower flute)	Nominal steel shear strength of single insert in the soffit of concrete on steel deck	$V_{sa,insert,deck} (lowerflute)$	lb (kN)	2,280 (10.1)	4,260 (18.9)	5,735 (25.5)
	Nominal steel shear strength of single insert in the soffit of concrete on steel deck, seismic	$V_{sa,insert,deck,eq} (lowerflute)$		2,015 (9.0)	3,410 (15.2)	

For SI: 1 inch = 25.4 mm, 1 pound = 4.45 N, 1 psi = 0.006895 MPa. For pound-inch unit: 1 mm = 0.03937 inches.

¹Concrete must have a compressive strength f'_c of 3,000 psi (20.7 MPa) minimum. Installation must comply with Sections 4.1.11 and 4.3 of this report.

²Design of headed cast-in specialty inserts shall be in accordance with the provisions of ACI 318-19 Chapter 17 for cast-in headed anchors. Concrete breakout strength must also be in accordance with [Figure 4](#).

³Strength reduction factors for the inserts shall be taken from ACI 318-19 Section 17.5.3 for cast-in headed anchors. Strength reduction factors for load combinations in accordance with ACI 318-19 Section 5.3 governed by steel strength of the insert shall be taken as 0.75 for tension and 0.65 for shear; values correspond to ductile steel elements. The value of ϕ applies when the load combinations of Section 1605.1 of the 2024 IBC or ACI 318-19 Section 5.3 are used in accordance with ACI 318-19 Section 17.5.3.

⁴Insert O.D. is the nominal bolt diameter of the insert.

⁵Minimum spacing distance between anchors and minimum edge distances for cast-in headed DDI+ inserts shall be in accordance with [Tables 1](#) and [2](#), [Figures 3A, 3B](#) and [3C](#) and noted provisions.

⁶Shear loads for concrete inserts in concrete-filled steel deck assemblies may be applied in any direction (i.e. over upper flute, over flute incline, over lower flute).

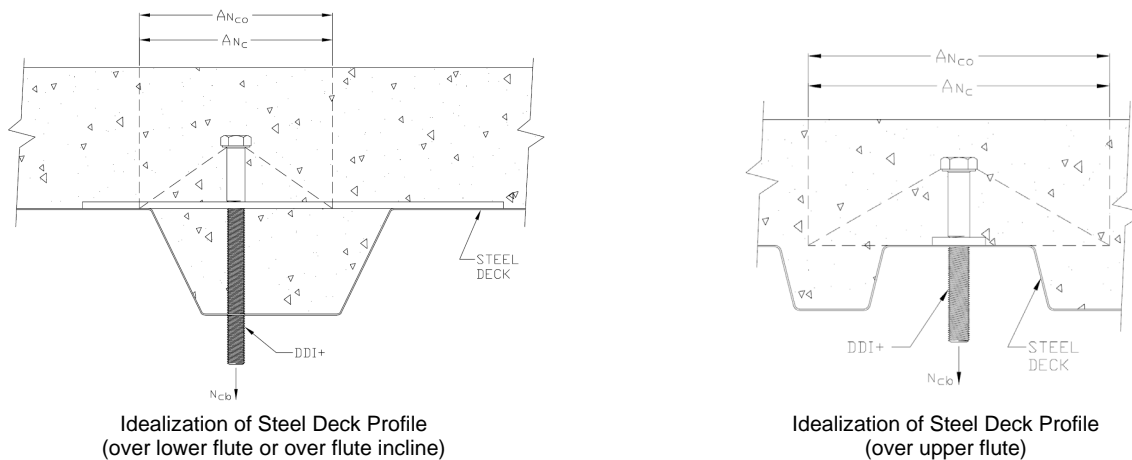

FIGURE 4—IDEALIZATION OF CONCRETE FILLED STEEL DECKS FOR DETERMINATION OF CONCRETE BREAKOUT STRENGTH IN ACCORDANCE WITH ACI 318

TABLE 3— APPLICABLE SECTIONS OF THE IBC CODE UNDER EACH EDITION OF THE IBC

2024 IBC	2021 IBC	2018 IBC	2015 IBC
Section 1605.1		Section 1605.2 or 1605.3	
Section 1705.1.1 and Table 1705.3			
Section 1901.3			
Sections 1903 and 1905			
Section 1905.7	Section 1905.1.8		

TABLE 4— APPLICABLE SECTIONS OF ACI 318 UNDER EACH EDITION OF THE IBC

2024 IBC	2021 IBC	2018 IBC	2015 IBC
ACI 318-19		ACI 318-14	
5.3		5.3	
Chapter 17		Chapter 17	
17.3.1		17.2.7	
17.5.1.2		17.3.1	
17.5.1.3		17.3.1.1	
17.5.3		17.3.3	
17.6		17.4	
17.6.1		17.4.1	
17.6.2		17.4.2	
17.6.2.1		17.4.2.1	
17.6.2.2		17.4.2.2	
17.6.2.5		17.4.2.6	
17.6.2.6		17.4.2.7	
17.6.3		17.4.3	
17.6.3.1		17.4.3.1	
17.6.3.2.2		17.4.3.4	
17.7		17.5	
17.7.1.2		17.5.1.2	
Eq. 17.7.1.2a		Eq. 17.5.1.2a	
Eq. 17.7.1.2b		Eq. 17.5.1.2b	
17.7.2		17.5.2	
17.7.3		17.5.3	
17.8		17.6	
17.9		17.7	
17.9.2		17.7.2	
17.10		17.2.3	

DIVISION: 03 00 00—CONCRETE
Section: 03 15 19—Cast-In Concrete Anchors
Section: 03 16 00—Concrete Anchors

REPORT HOLDER:

DEWALT

EVALUATION SUBJECT:

DDI+™ HEADED CAST-IN SPECIALTY INSERTS FOR CRACKED AND UNCRACKED CONCRETE-FILLED STEEL DECKS (DEWALT)

1.0 REPORT PURPOSE AND SCOPE**Purpose:**

The purpose of this evaluation report supplement is to indicate that DDI+™ Headed Cast-In Specialty Inserts for Cracked and Uncracked Concrete-Filled Steel Decks, described in ICC-ES evaluation report [ESR-3958](#), have also been evaluated for compliance with the codes noted below as adopted by Los Angeles Department of Building and Safety (LADBS).

Applicable code editions:

- 2023 *City of Los Angeles Building Code* ([LABC](#))
- 2023 *City of Los Angeles Residential Code* ([LARC](#))

2.0 CONCLUSIONS

The DDI+™ Headed Cast-In Specialty Inserts for Cracked and Uncracked Concrete-Filled Steel Decks, described in Sections 2.0 through 7.0 of the evaluation report [ESR-3958](#), comply with LABC Chapter 19, and LARC, and are subjected to the conditions of use described in this report.

3.0 CONDITIONS OF USE

The DDI+™ Headed Cast-In Specialty Inserts for Cracked and Uncracked Concrete-Filled Steel Decks described in this evaluation report supplement must comply with all of the following conditions:

- All applicable sections in the evaluation report [ESR-3958](#).
- The design, installation, conditions of use and labeling of the inserts are in accordance with the 2021 *International Building Code*® (IBC) provisions noted in the evaluation report [ESR-3958](#).
- The design, installation and inspection are in accordance with additional requirements of LABC Chapters 16 and 17, as applicable.
- Under the LARC, an engineered design in accordance with LARC Section R301.1.3 must be submitted.
- The allowable and strength design values listed in the evaluation report and tables, are for the connection of the inserts to the concrete. The connection between the inserts and the connected members shall be checked for capacity (which may govern).

This supplement expires concurrently with the evaluation report, reissued December 2024.

DIVISION: 03 00 00—CONCRETE**Section: 03 15 19—Cast-in Concrete Anchors****Section: 03 16 00—Concrete Anchors****REPORT HOLDER:****DEWALT****EVALUATION SUBJECT:****DDI+™ HEADED CAST-IN SPECIALTY INSERTS FOR CRACKED AND UNCRACKED CONCRETE-FILLED STEEL DECKS (DEWALT)****1.0 REPORT PURPOSE AND SCOPE****Purpose:**

The purpose of this evaluation report supplement is to indicate that the DEWALT DDI+ inserts, described in ICC-ES evaluation report ESR-3958, have also been evaluated for compliance with the codes noted below.

Applicable code editions:

- 2023 *Florida Building Code—Building*
- 2023 *Florida Building Code—Residential*

2.0 CONCLUSIONS

The DEWALT DDI+ inserts, described in Sections 2.0 through 7.0 of the evaluation report ESR-3958, comply with the *Florida Building Code—Building* and the *Florida Building Code—Residential*. The design requirements must be determined in accordance with the *Florida Building Code—Building* or the *Florida Building Code—Residential*, as applicable. The installation requirements noted in ICC-ES evaluation report ESR-3958 for the 2021 *International Building Code*® meet the requirements of the *Florida Building Code—Building* or the *Florida Building Code—Residential*, as applicable.

Use of the DDI+ inserts has also been found to be in compliance with the High-Velocity Hurricane Zone Provisions of the *Florida Building Code—Building* and *Florida Building Code—Residential* with the following condition:

- a) For connections subject to uplift, the connection must be designed for no less than 700 pounds (3114 N).

For products falling under Florida Rule 61G20, verification that the report holder's quality-assurance program is audited by a quality-assurance entity approved by the Florida Building Commission for the type of inspections being conducted is the responsibility of an approved validation entity (or the code official, when the report holder does not possess an approval by the Commission).

This supplement expires concurrently with the evaluation report, reissued December 2024.