

TRAK-IT TOOL MODEL TI-C5

TRAK-IT[®] TOOL

OPERATORS MANUAL

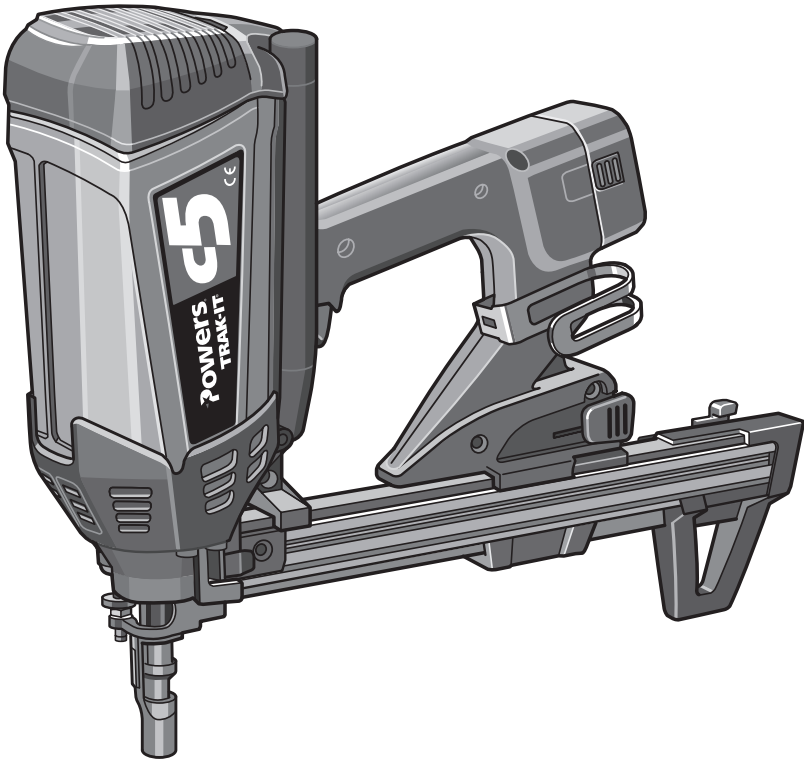

TI-C5

INDEX INDEX ÍNDICE

ENGLISH	Page	3	to	21
FRANÇAIS	Page	**	to	**
ESPAÑOL	Page	**	to	**

DEFINITIONS OF SIGNAL WORDS

- WARNING:** Indicates a potentially hazardous situation which, if not avoided, could result in death or serious injury.
- CAUTION:** Indicates a potentially hazardous situation which, if not avoided, may result in minor or moderate injury.
- NOTE:** Emphasizes essential information.

DÉFINITIONS DES DIFFÉRENTS DEGRÉS D' AVERTISSEMENTS

- AVERTISSEMENT:** Indique une situation éventuellement dangereuse qui, si elle n'est pas contournée, pourrait provoquer la mort ou des blessures sérieuses.
- ATTENTION:** Indique une situation éventuellement dangereuse qui, si elle n'est pas contournée, pourrait provoquer des blessures légères à moyennement sérieuses.
- REMARQUE:** Souligne des informations importantes.

DEFINICIÓN DE LAS INDICACIONES DE ADVERTENCIA

- ADVERTENCIA:** Indica una situación potencialmente peligrosa que podría causar la muerte o graves lesiones si no se evita.
- PRECAUCIÓN:** Indica una situación potencialmente peligrosa que podría causar lesiones menos graves o leves si no se evita.
- NOTA:** Resalta informaciones importantes.

ENGLISH

OPERATING and MAINTENANCE MANUAL

INDEX

1. SAFETY INSTRUCTIONS.....	3
2. SPECIFICATIONS AND TECHNICAL DATA	10
3. SAFETY DEVICES	11
4. HOW TO USE THE BATTERY AND THE CHARGER	11
5. HANDLING OF FUEL CELL	14
6. INSTRUCTIONS FOR OPERATION	15
7. MAINTAIN FOR PERFORMANCE	19
8. STORING	20
9. TROUBLE SHOOTING/REPAIRS	20



WARNING

BEFORE USING THIS TOOL, STUDY THIS MANUAL TO ENSURE SAFETY WARNING AND INSTRUCTIONS.
KEEP THESE INSTRUCTIONS WITH THE TOOL FOR FUTURE REFERENCE.

1. SAFETY INSTRUCTIONS



WARNING

TO AVOID SEVERE PERSONAL INJURY OR PROPERTY DAMAGE

BEFORE USING THE TOOL, READ CAREFULLY AND UNDERSTAND THE FOLLOWING "SAFETY INSTRUCTIONS". FAILURE TO FOLLOW WARNINGS COULD RESULT IN DEATH OR SERIOUS INJURY.

PRECAUTIONS ON USING THE TOOL



1. WEAR EYE PROTECTION

Danger to the eyes always exists due to the possibility of dust being blown up by the exhausted air or of a fastener flying up due to the improper handling of the tool. For these reasons, eye protection shall always be worn when operating the tool.

The employer and/or user must ensure that proper eye protection is worn. Eye protection equipment must conform to the requirements of the American National Standards Institute, ANSI Z87.1 (Council Directive 89/686/EEC of 21 DEC. 1989) and provide both frontal and side protection.

The employer is responsible to enforce the use of eye protection equipment by the tool operator and all other personnel in the work area.

NOTE: Non-side shielded spectacles and face shields alone do not provide adequate protection.



2. EAR PROTECTION MAY BE REQUIRED IN SOME ENVIRONMENTS

As the working condition may include exposure to high noise levels which can lead to hearing damage, the employer and user should ensure that any necessary hearing protection is provided and used by the operator and others in the work area.

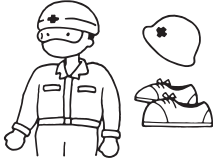

- 3. WEAR THE CLOTHINGS AND A PROTECTIVE GEAR SUITABLE FOR THE WORKING ENVIRONMENT**
Depending on the working environment, wear a long-sleeve work uniform and a protective gear such as a hard hat, safety shoes.



- 4. CAUTIONS FOR FUEL CELL**
- 1** Be sure to set Fuel Cell.
 - 2** Store Fuel Cell in well ventilated area.

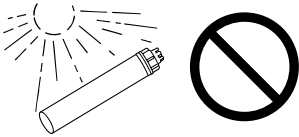

- 3** Do not expose the Fuel Cell to the direct sunshine.
Do not place the Fuel Cell in a vehicle or a trunk where the temperature could rise. It could explode. A used empty Fuel Cell still contains a combustible jet gas, which could swell and explode a container into pieces.

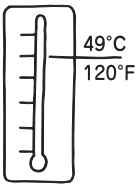

- 4** Store the Fuel Cell at ambient temperature of 120°F (49°C) or lower.
The Fuel Cell contains the pressurized combustible gas. If it is exposed to the temperature higher than 120°F (49°C), the gas could leak from it or burst, resulting in a fire.



- 5** Do not breathe in the gas.

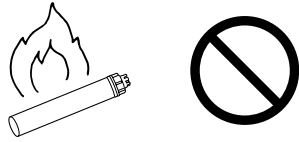

- 6** Do not incinerate or recycle the empty Fuel Cell.



- 7** Never jet the gas to the human body.

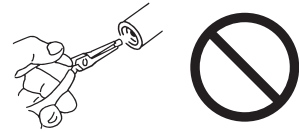

- 8** Do not remove the rubber plug from the bottom of the Fuel Cell except at disposal.

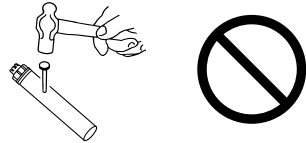

- 9** Do not make a hole in the Fuel Cell.

- 5. CAUTIONS FOR CHARGING METHOD, THE CHARGER AND THE BATTERY**

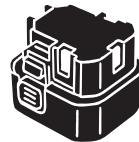

- 1** Be sure to use Battery (Cat.#55583).
Be sure to use Battery (Cat.#55583) for the tool. Never connect the tool to a power source or other rechargeable battery, dry cells or storage battery for automobiles. Neglect of this could cause breakage, trouble, heat generation or combustion.
(See Page 11 for Battery (Cat.#55583))

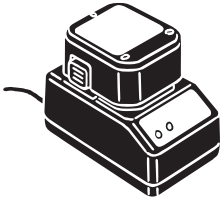

- 2 Be sure to charge with Charger Base (Cat.#55618).**
Be sure to charge the Battery with Charger Base (Cat.#55618).
If charged with other charger, it could fail to be properly charged as well as get broken, ignited or generate the heat.
(See Page 10 for Charger Base (Cat.#55618))

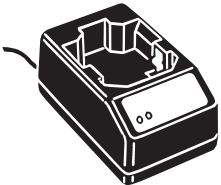

- 3 Charge the Battery prior to use.**
The new Battery or the one which has not been used for a long period may not be fully charged due to self-discharge. Be sure to charge it with Charger Base (Cat.#55618).



- 4 Charge the Battery at the specified voltage.**
Be sure to charge, using a 100-240 V AC plug socket (for household use). Never charge at other than the specified voltage. Neglect of this could cause combustion or heat generation.



- 5 Never use a transformer such as a booster for the power source of the charger.**
Neglect of this causes a trouble or burnout of the charger.

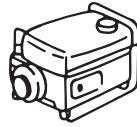

- 6 Never use an engine generator or DC power source to charge the Battery.**
Neglect of this causes a trouble or burnout of the charger.



- 7 Never charge the Battery in the rain or in the place exposed to water splash or moisture.**
If it is charged in the wet condition, it could cause an electric shock or short-circuiting, resulting in a fire due to burnout or combustion.

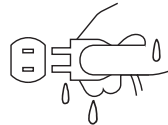

- 8 Never touch a power plug with a wet hand.**
Holding it with a wet hand could cause an electric shock.



- 9 Never cover the charger in use with a cloth, and so on.**
Putting a cover could generate the heat, resulting in a burnout or fire.

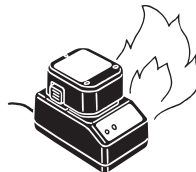

- 10 Do not put the charger close to a fire.**

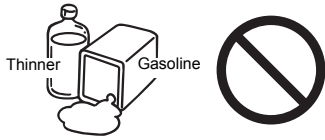

- 11 Do not charge the Battery near any combustible substance.**

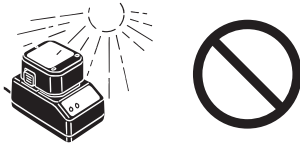

- 12 Charge the Battery in a well-ventilated area, protected against the direct sunshine.**
Charging in the direct sunshine could overheat the charger, resulting in a burnout or fire.

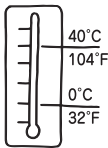

- 13 Charge the Battery at ambient temperature of 32°F (0°C) to 104°F (40°C).**
If the ambient temperature is less than 32°F (0°C) to 104°F (40°C), charging may not be allowed, could result in a fire.



- 14 Do not allow foreign objects into a ventilation hole or Battery plug socket in the charger.**
They cause an electric shock or trouble. Use in the place free of dust.



- 15 Handle a power cord with care.**
If you hold the power cord of the AC adapter to carry or pull it to disconnect from a plug socket, it will be damaged, resulting in snapping or short-circuiting. Also, take care that it will not come into contact with cutters, high-temperature substances, oil or grease. Replace the damaged power cord with a new one.



- 16 Once the Battery is disconnected from the tool body, be sure to cover it with a pack cap, unless it is used.**
In order to prevent short-circuiting, cover the terminal block (metal section) of the unused Battery with the pack cap.

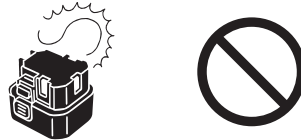

- 17 Never short-circuit the terminal block (metal section) of the Battery.**
If it is short-circuited, a large current will run to overheat the Battery, causing you a burn or damage on it.



- 18 Never throw the Battery into a fire.**
Neglect of this could cause an explosion.

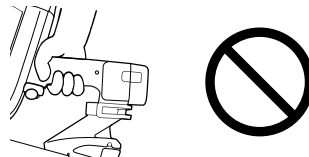

- 6. CARE SHOULD BE TAKEN WHEN CONNECTING THE BATTERY TO THE TOOL**
When connecting the Battery to the tool, be sure to observe the following in order to prevent malfunctioning.
- (1) Do not put your finger on the trigger.
 - (2) Do not press the contact arm against the object.
 - (3) Never put your finger or hand near the muzzle.

- 7. BE SURE TO CHECK WHEN THE BATTERY IS CONNECTED**
Prior to using the tool, connect the Battery to it without pressing the contact arm against the object and loading the pins and Fuel Cell, and be sure to check the following:



- (1) Check whether or not operating sound is heard, by only connecting the Battery.

* The fan inside the tool starts running when battery is on the tool and the contact arm is depressed. This is normal and not a malfunction.



- (2) Check for heat generation or abnormal smell or sound. If the tool is activated, generates the heat or emits abnormal smell or sound, it is an indication of trouble. Using the tool in that condition results in an accident. If any abnormality is found, contact your nearest authorized distributor.

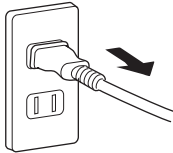

8. **UNPLUG THE CHARGER WHEN IT IS NOT USED**

9. **ONLY USE TOOL IN WELL VENTILATED AREA**

If used in an ill-ventilated place, you could suffer from oxygen starvation.



10. **AVOID THE DIRECT SUNSHINE**

Do not place the tool in a vehicle or a trunk where the temperature could rise, because it could explode. A used empty Fuel Cell still contains a combustible jet gas, which could swell and explode a container into pieces.

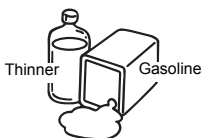

11. **NEVER USE THE TOOL NEAR THE VOLATILE COMBUSTIBLE SUBSTANCES**

Never use the tool near gasoline, thinner, gas, paint or adhesive agent, because it could ignite or explode.



12. **KEEP TOOL AWAY FROM FIRE**

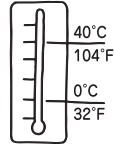

13. **BE SURE TO USE THE TOOL IN THE WORKING ENVIRONMENT OF 19°F (-7°C) TO 120°F (49°C), BECAUSE THE TOOL BODY COULD BE DAMAGED, IGNITE OR EXPLODE**

19°F (-7°C) or lower: The tool body could be damaged. 120°F (49°C) or higher: The Fuel Cell could be damaged, resulting in ignition or explosion.



14. **DO NOT USE THE TOOL IN THE RAIN OR IN A VERY HUMID PLACE**

Neglect of this causes a trouble.



15. **NEVER DRIVE THE PINS, FACING EACH OTHER**

If you drive the pins, facing each other, an improperly driven pin may hit and injure the worker facing you.



16. **BEWARE OF THE HIGH TEMPERATURE OF THE TOOL**

If the tool is used for a long period of time, the nose and contact arm will become hot. Be careful not to get a burn.

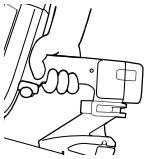

- 17. WHEN USING THE HOOK, BE SURE TO RELEASE YOUR FINGER FROM THE TRIGGER**



- 18. REMOVE THE FUEL CELL AND THE BATTERY AND EMPTY THE MAGAZINE WHEN THE TOOL IS NOT IN USE**

Always remove the Fuel Cell and the Battery from the tool and empty the magazine when operation has been completed or suspended, when unattended, moving to a different work area, adjusting, disassembling, or repairing the tool, and when clearing a jammed fastener.



- 19. INSPECT SCREW TIGHTNESS**

Loose or improperly installed screws or bolts cause accidents and tool damage when the tool is put into operation. Inspect to confirm that all screws and bolts are tight and properly installed prior to operating the tool.



CAUTION

Be sure that the tool has been cooled down.



- 20. DO NOT TOUCH THE TRIGGER UNLESS YOU INTEND TO DRIVE A FASTENER**

Never touch the trigger unless you intend to drive a fastener into the work. It is dangerous to walk around carrying the tool with the trigger pulled, and this and similar actions should be avoided.



- 21. NEVER POINT THE DISCHARGE OUTLET TOWARD YOURSELF AND OTHER PERSONNEL**

If the discharge outlet is pointed toward people, serious accidents may be caused when misfiring. Be sure the discharge outlet is not pointed toward people when the Fuel Cell and the Battery are inserted or not, loading and unloading the fasteners or similar operations.

- 22. USE SPECIFIED FASTENERS**

The use of fasteners other than specified fasteners will cause the tool malfunction. Be sure to use only specified fasteners when operating the tool.

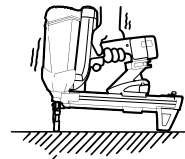

- 23. PLACE THE DISCHARGE OUTLET ON THE WORK SURFACE PROPERLY**

Failure to place the discharge outlet of the nose in a improper manner can result in a fastener flying up and is extremely dangerous.



- 24. KEEP HANDS AND BODY AWAY FROM THE DISCHARGE OUTLET**

When loading and using the tool, never place a hand or any part of body in fastener discharge area of the tool. It is very dangerous to hit the hands or body by mistake.

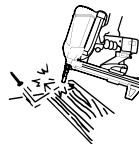

- 25. DO NOT DRIVE FASTENERS CLOSE TO THE EDGE AND CORNER OF THE WORK AND THIN MATERIAL**

The workpiece is likely to split and the fastener could fly free and hit someone.

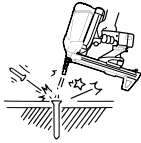

26. DO NOT DRIVE FASTENERS ON TOP OF OTHER FASTENERS

Driving fasteners of the top of other fasteners may cause deflection fasteners which could cause injury.

27. REMOVING THE FASTENERS AFTER COMPLETING OPERATION

If fasteners are left in the magazine after the completion of operation, there is the danger of a serious accident occurring prior to the resumption of operation, should the tool be handled carelessly, or when inserting the Fuel Cell and the Battery. For this reason, always remove all fasteners remaining in the magazine after completion of the operation.

28. CHECK OPERATION OF THE CONTACT TRIP MECHANISM FREQUENTLY

Do not use the tool if the trip is not working correctly as accidental driving of a fastener may result. Do not interfere with the proper operation of the contact trip mechanism.

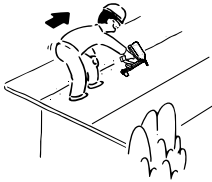

29. WHEN USING THE TOOL OUTSIDE OR ELEVATED PLACE

When fastening roofs or similar slanted surface, start fastening at the lower part and gradually work your way up. Fastening backward is dangerous as you may loose your foot place.

30. NEVER USE THE TOOL IF ANY PORTION OF THE TOOL CONTROLS (e.g., TRIGGER, CONTACT ARM) IS INOPERABLE, DISCONNECTED, ALTERED OR NOT WORKING PROPERLY

31. NEVER ACTUATE THE TOOL INTO FREE SPACE

This will avoid any hazard caused by free flying fasteners and excessive strain of the tool.

32. ALWAYS ASSUME THAT THE TOOL CONTAINS FASTENERS

33. RESPECT THE TOOL AS A WORKING IMPLEMENT

34. NO HORSEPLAY

35. NEVER LOAD THE TOOL WITH FASTENERS WHEN ANY ONE OF THE OPERATING CONTROLS (e.g., TRIGGER, CONTACT ARM) IS ACTIVATED



36. TAKE GOOD CARE OF THE TOOL

Clean the tool with dry soft cloth. Never use wet cloth or volatile solutions such as thinner, benzine.

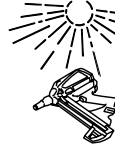

37. AVOID THE DIRECT SUNSHINE

Do not leave the tool or Charger in the direct sunshine for a long time.

OBSERVE THE FOLLOWING GENERAL CAUTION IN ADDITION TO THE OTHER WARNINGS CONTAINED IN THIS MANUAL

- Do not use the tool as a hammer.
- The tool must be used only for the purpose it was designed.
- Never remove, tamper with the operating controls (e.g., TRIGGER, CONTACT ARM)
- Keep the tool, the Fuel Cell and the Battery in a dry place out of reach of children when not in use.
- Do not use the tool without Safety Warning label.
- Do not modify the tool from original design or function.

2. SPECIFICATIONS AND TECHNICAL DATA

1. NAME OF PARTS

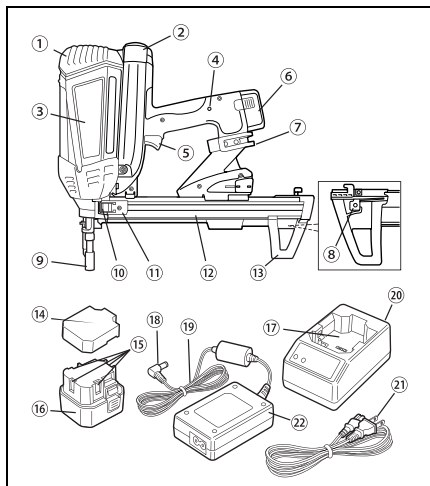

- | | |
|---------------------|----------------------------|
| ① Cylinder Cap Unit | ⑫ Magazine |
| ② Fuel Cap | ⑬ Magazine Foot |
| ③ Housing | ⑭ Pack Cap |
| ④ LED | ⑮ Terminal Block |
| ⑤ Trigger | ⑯ Battery (Cat.#55583) |
| ⑥ Battery | ⑰ Battery Setting Hollow |
| ⑦ Hook | ⑱ Jack |
| ⑧ Nail Stopper | ⑲ Power Cord |
| ⑨ Contact Arm | ⑳ Charger Base(Cat.#55618) |
| ⑩ Follower Holder | ㉑ Power Plug |
| ⑪ Follower | ㉒ AC Adapter |

NOTE: The triangle symbol marked as "▽" following its tool serial number indicates that safety yoke is equipped with this tool.

2. TOOL SPECIFICATIONS

PRODUCT NO.	TI-C5
HEIGHT	14-3/8" (365 mm)
WIDTH	4-7/8" (124 mm)
LENGTH	17-1/8" (435 mm)
WEIGHT	8.1 lbs. (3.7 kg) (including Fuel Cell and Battery)
LOADING CAPACITY	42 pins
BATTERY	Battery (Cat.#55583)
BATTERY CAPACITY	6V DC, 1.5 Ah
CHARGER	Charger base (Cat.#55618)
POWER SOURCE	100-240V AC, 50 or 60 Hz
POWER CONSUMPTION (Rated output)	8VA (10V 800mA)
CHARGING TIME	150 minutes at maximum
ACCESSORIES	Safety Glasses, Carrying case, Battery, Charger, Jam clear tool

3. FASTENER SPECIFICATIONS

PRODUCT NO.	TI-C5
PIN LENGTH	1/2" to 1-1/4" (12 to 32 mm)
SHANK DIAMETER	.102", .120", .145" (2.6 mm, 3.0 mm, 3.7 mm)
SHANK TYPE	Smooth, Step
HEAD DIAMETER	.252" (6.4 mm)

4. TECHNICAL DATA

① NOISE

A-weighted single-event ----- LWA, 1s, d 103.38 dB
sound power level

A-weighted single-event ----- LpA, 1s, d 97.34 dB
emission sound pressure
level at work station

These values are determined and documented in accordance to EN12549 : 1999.

② VIBRATION

Vibration characteristic value = 6.00 m/s²

These values are determined and documented in accordance to ISO 8662-11.

This value is a tool-related characteristic value and does not represent the influence to the hand-arm-system when using the tool.

An influence to the hand-arm-system when using the tool will for example depend on the gripping force, the contact pressure force, the working direction, the workpiece, the workpiece support.

3. SAFETY DEVICES

The tool is provided with the following safety devices in order to secure safety for pin driving work.

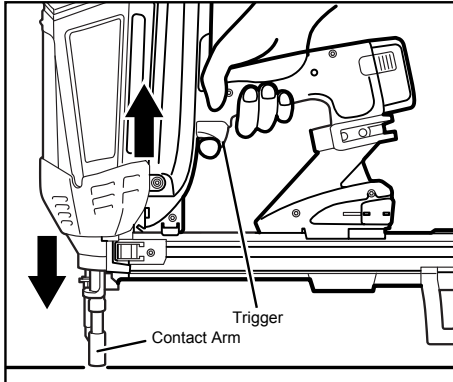

Mechanical Safety Device

This tool is equipped with a FULL SEQUENTIAL ACTUATION MECHANISM. This tool will not discharge pins unless the Contact Arm and Trigger have been activated simultaneously. The pins are not discharged by neither simply pulling the Trigger nor applying the Contact Arm to the pins driving object. The pins are discharged only after applying the Contact Arm to the object and pulling the Trigger.



CAUTION

- Prior to using the tool, be sure to inspect it to see whether the safety devices function properly. Do not use it if they do not function properly.
Prior to using the tool, check whether the safety devices function properly. With no pins loaded, install the Battery and Fuel Cell to check.
- * In the following cases, the safety devices are out of order. Never use the tool.
 1. An operating sound is emitted by simply pulling the trigger.
 2. The tool starts dry-fire operation by simply applying the contact arm to the object.
- * A fan running sound is heard, this is OK.
If any abnormality is found, contact your nearest authorized distributor for inspection/repairing.



WARNING

- To avoid accidental firing or double firing, pull the trigger rapidly and firmly.

4. HOW TO USE THE BATTERY AND THE CHARGER



WARNING

- Be sure to charge Battery (Cat.#55583) for the tool with Charger Base (Cat.#55618).
If charged with other charger, the Battery could fail to be properly charged as well as get broken, ignited or generate the heat.
- Do not put the Battery close to a fire.
- Do not leave the Battery in the direct sunshine.
- Do not charge or use the Battery in the wet condition with a liquid such as water, sea water, milk, soft drink, soap water.
- Unplug the charger when it is not used.
- Be sure to charge at 32°F (0°C) to 104°F (40°C) to avoid the possibility of fire.
- Do not give a strong shock such as hitting with a hammer, stamping or dropping.



CAUTION

- When the Battery is discharged or is not used for a long period, remove it from the Charger.
- After setting the Battery in the tool, do not hold it to carry around.

PROPER USE OF BATTERY

- ① Fully charge and discharge the Battery.
If you repeat charging the Battery while not fully discharged more than half the capacity, the number of pins drivable by each charging could decrease dramatically, shortening the life of the Battery. It is recommended to use it until the LED of the tool has been illuminated in red, running out of electricity.
- ② Use two Batteries alternately.
To ensure the longer life of the Battery, it is recommended to use two of them alternately, preparing a spare one.

Recycling the Nickel-Hydrogen Battery

The Battery for the tool uses nickel-hydrogen batteries which are a precious recyclable resource. Once the Battery runs out of life, take it to your nearest distributor without disposing of it.



WARNING

- In order to prevent short-circuiting, be sure to cover the terminal block (metal section) of the Battery with the Pack Cap (wind the insulating tape) for recycling.

<Battery cells in Battery Pack>

- Nominal voltage: 1.2 V/piece
- Quantity used in 1 pack: 5 pieces

HOW TO USE THE CHARGER

The special purpose charger Base (Cat.#55618) has the LEDs (green, red) which indicate the status of the charger and Battery.

	Green LED	Red LED	Status	Description
1.	○ ON	● OFF	Power-on	The charger has been plugged in. (Power-on status;Battery unset)
2.	● OFF	○ ON	Charging	The Battery is being charged.
3.	○ ON	● OFF	Charge Completed	The Battery has been completed charged.
4.	Blinking	Blinking	High temperature alarm	The Battery is hot. (Remove it from the Charger and cool it down for a while before charging.)
5.	○ ON	○ ON	Battery alarm	The Battery is defective. (Replace it with a new one)
6.	Blinking	○ ON	Battery high temperature alarm	The Battery is defective and hot. (Replace it with a new one.)

Battery Charger problems

The following cases are considered to be the problems. Replace the charger and Battery with new ones.

- The green LED is not turned on if the power plug of the charger is plugged into a 100-240 V AC (for household use) plug socket. (With the Battery unset)
- * Check with another electric appliance to see whether electricity is available at the plug socket.
- Neither green nor red LED is turned on or blinks if the Battery is set in the Charger.
- The green LED is not turned on 150 minutes after the red one has been turned on.
- The red LED is not turned on if the Battery is set in the charger.

HOW TO CHARGE



WARNING

- Charge the Battery at the specified voltage. Be sure to charge from a 100-240 V AC (for household use) plug socket. Use of the non-specified voltage not only causes a trouble, but also is dangerous.
- Handle the power cord with care. Do not use the Charger whose power cord is damaged.
- Use a proper plug socket. Use of the rickety or slack plug socket causes an accident due to overheat. If this is the case, use another proper one.

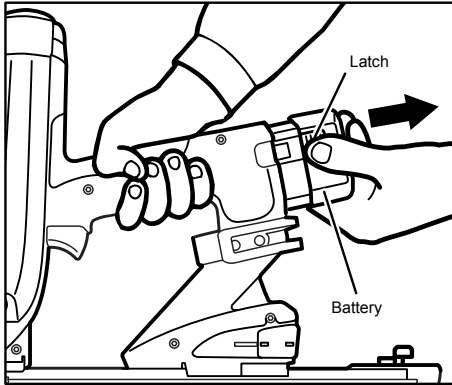

- ① If the Battery is used up, remove it from the tool. Firmly holding the tool body, press the latches on both side of the Battery with your fingers to remove.

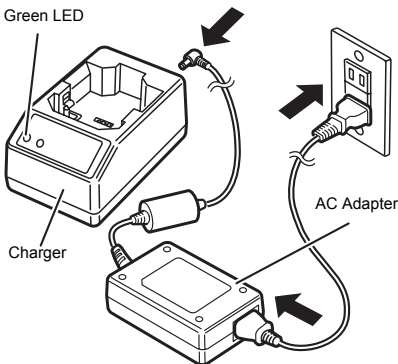

- ② Insert the AC adapter's jack into the Charger and plug the power plug into a plug socket. The green LED is turned on to inform you of the power-on status.

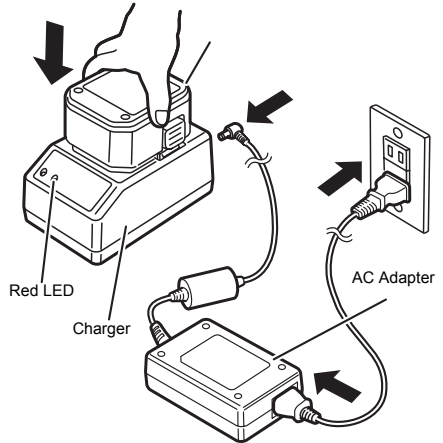

- ③ Charge the Battery.
 - (1) Set the Battery firmly in the charger.
 - (2) Once it is set in the charger, charging will start automatically. The red LED is turned on to inform you that charging is under way.
 - (3) The maximum charging time is approx. 150 minutes. The charging time depends on the temperature, supply voltage or remaining battery capacity. Once charging is fully completed, the green LED will be illuminated to inform you that charging has been completed. If the fully charged Battery is set in the charger again, the red LED will be turned on again, indicating that it is being charged. This is not an abnormality. After a while, the green LED will be turned on to indicate completion of charging.



CAUTION

- Do not try to charge the Battery which has been fully charged. The life of the Battery could be shortened.
- ④ The Illuminated Green LED Indicates completion of charging.
 - (1) Holding down the charger, remove the Battery.
 - (2) Disconnect the AC adapter's power plug from the plug socket.

Now Charging is complete.

Preventing the Battery Pack from becoming inactive

In the following cases the Battery Pack must be charged for 24 HOURS to reach top performance:

- Upon purchasing the tool.
- When the tool has not been used for 1 month or longer.
- When it is clear that you can drive less pins even when fully charged.

After the Charge Complete lamp has been turned on, leave the Battery set in the Charger for about another 24 hours.



CAUTION

- After completing your work or when the tool is not used, be sure to remove the Battery Pack from the tool to store it. (Remove the Fuel Cell and pins as well)
If it is left connected, the electric power will be consumed in the standby state.

5. HANDLING OF FUEL CELL

The Fuel Cell is doubly structured; the inner container has been filled with a liquid fuel gas and the outer one with a propellant gas (another pressurized gas).

Like squeezing a toothpaste tube, the inner fuel gas is pushed out by the pressure of the propellant gas, thus being used up to the last without wasting it. Because of this structure, the combustible propellant gas in the outer container remains even after the fuel gas in the inner container has been used.

Therefore, utmost care should be taken when disposing the empty Fuel Cell.



WARNING

- Be sure to use the Fuel Cell exclusively designed for the Gas powered Fastening System.
- Never smoke a cigarette when attaching or operating a metering valve.
- Do not remove the rubber plug from the bottom of the Fuel Cell except at disposal.
- Do not make a hole in the Fuel Cell.
- Be careful not to breathe in the gas. Breathing in the gas could cause sleepiness, dizziness or nausea.
- Never jet the gas to the human body.
- Do not incinerate or recycle the empty Fuel Cell. (See Page 15 for disposal of the Fuel Cell)

INSERTING THE FUEL CELL INTO THE TOOL



WARNING

- Be sure to release your finger from the Trigger.
- Do not press the Contact Arm against the object.

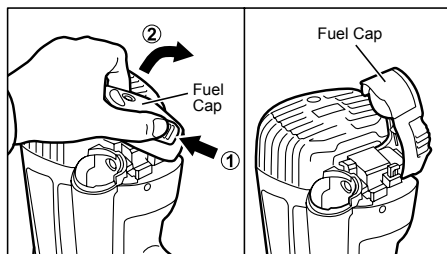

- ① Press the Latch, then pull the Fuel Cap.

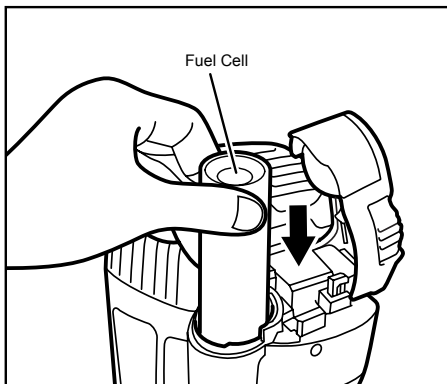

- ② Insert the Fuel Cell into the tool.

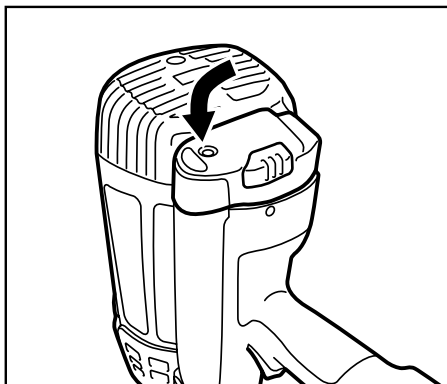

- ③ You complete the loading of the Fuel Cell by closing the Fuel Cap until it clicks.

* When the Fuel Cap is closed with the battery on the tool, the Solenoid valve in the tool pushes out the air from the Solenoid valve chamber and you hear a sound of air blow. This is the normal sound for the tool activation.

DISPOSING OF THE USED FUEL CELL

Combustible jet gas still remains in the used Fuel Cell.



WARNING

- Do not throw the used Fuel Cell into a fire.
- Never smoke a cigarette.
- Never breathe in the gas.

6. INSTRUCTIONS FOR OPERATION

Read section titled "SAFETY INSTRUCTIONS".

1. BEFORE OPERATION

- 1 Wear Eye Protection.
- 2 Do not insert the Fuel Cell and Battery.
- 3 Inspect screw tightness.
- 4 Check operation of the Contact Arm & Trigger if moving smoothly.
- 5 Insert the Fuel Cell and Battery.
- 6 Hold the tool with finger-off the Trigger, then push the Contact Arm against the work-piece. (The tool must not operate.)
- 7 Hold the tool with Contact Arm free from work-piece and pull the Trigger. (The tool must not operate.)
- 8 Remove the Fuel Cell and Battery.



WARNING



2. OPERATION

Wear Eye Protection

Danger to the eyes always exists due to the possibility of dust being blown up by the exhausted air or of a fastener flying up due to the improper handling of the tool. For these reasons, eye protection shall always be worn when operating the tool.

The employer and/or user must ensure that proper eye protection is worn. Eye protection equipment must conform to the requirements of the American National Standards Institute, ANSI Z87.1 (Council Directive 89/686/EEC of 21 DEC. 1989) and provide both frontal and side protection.

The employer is responsible to enforce the use of eye protection equipment by the tool operator and all other personnel in the work area.

NOTE: Non-side shielded spectacles and face shields alone do not provide adequate protection.



WARNING



Keep hands and body away from the discharge outlet

When driving the fasteners because of dangerous of hitting the hands or body by mistake.

LOADING THE PINS



WARNING

- When loading the pins, be sure to release the finger from the Trigger.
- Do not press the Contact Arm against the object.

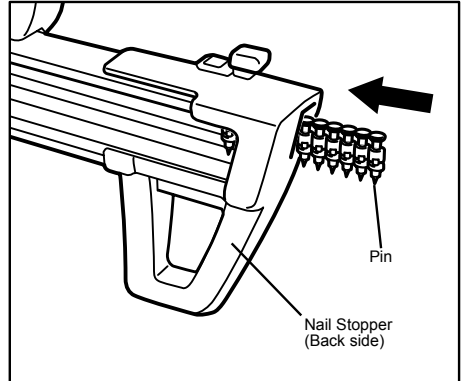

Procedure

- 1 Load the pins into the slit in the rear of the Magazine until they reach in front of the Nail Stopper.



CAUTION

- Abrupt release of the Follower Holder causes jamming of pins or dry-firing.

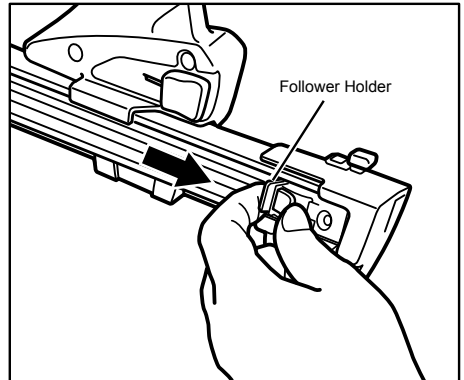

- 2 Pull the Follower Holder as far to the rear and of the magazine and release it gently.

HOW TO DRIVE THE PINS

Procedure

- ① Install the Battery and Fuel Cell.
- ② Press the nose of the Contact Arm against where you want to drive the pins.
The fan motor is activated, the fuel gas is jetted, mixing the fuel with the air.

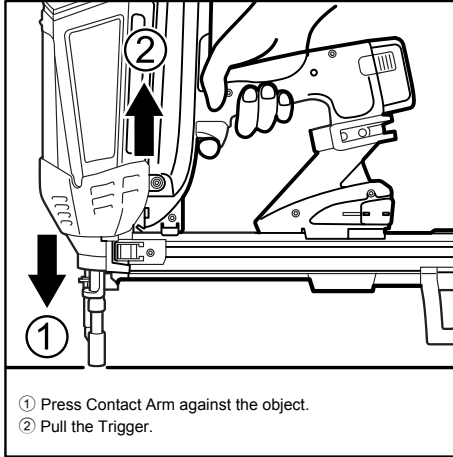

- ③ Firmly pressing the Contact Arm, pull the Trigger. The pins are driven into the object by combustion of the fuel.



WARNING

- Never put your face above the tool. Reaction of the tool may cause an unexpected injury.
 - Never bring your hand or finger close to the discharge outlet.
- ④ The pins are not shot even if the Contact Arm is applied to the object with the Trigger pulled. Release the Trigger and repeat Step ②.



CAUTION

- The fan keeps running even after driving the pins. The running time varies with operation speed.



WARNING

- Prior to starting work, be sure to check whether the tool functions as mentioned above.
- If the tool is used for a long period of time, it could get hot and burn you.
If any abnormality is found, contact your nearest authorized distributor for inspection and repairing.

DRIVING DEPTH ADJUSTMENT



WARNING

- ALWAYS remove Fuel Cell and Battery before making adjustment.



CAUTION

- The Depth Adjustment Dial may be hot.

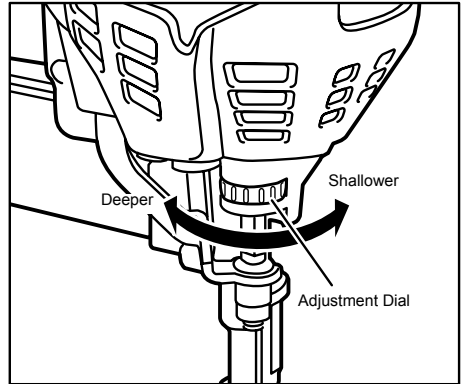

The driving depth adjustment is made by adjusting the Depth Adjustment Dial.

- ① With Fuel Cell and Battery install, drive a few nails into a representative material sample to determine if adjustment is necessary.
- ② If adjustment is required, remove Fuel Cell and Battery.
- ③ Refer to the mark on the Magazine for direction to turn the Adjustment Dial.
- ④ Reinstall Fuel Cell and Battery.

REMOVING THE PIN

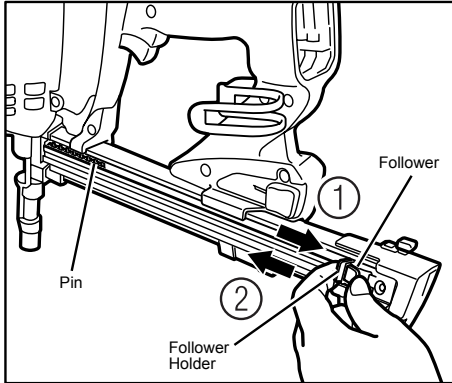

- 1 Pull the Follower Holder and press the Follower, then return the Follow Folder.

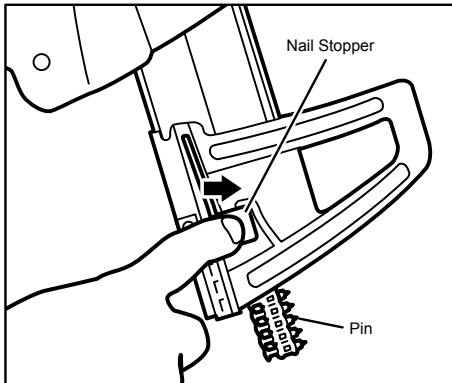

- 2 Set the Magazine vertical and push the Nail Stopper to remove the Pin. Be sure that no pins remain in the Nose or Magazine.

CHANGING THE HOOK DIRECTION

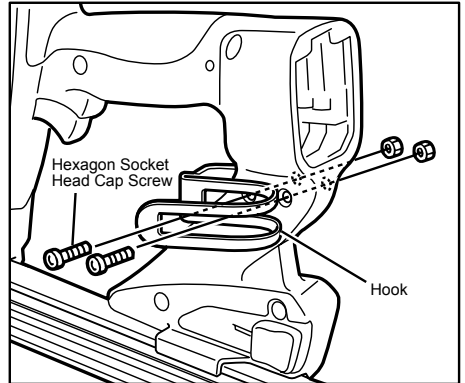

WARNING

- **Remove the Fuel Cell and Battery.**

The Hook can be directed in the two directions. Remove the hexagon socket head cap screw with hexagon wrench, change the direction, and then, put back the bolts to reassemble.

REPLACING THE FUEL CELL

If the Fuel Gas is low, the pins cannot be driven.



WARNING

- **Be sure to release the Trigger.**
- **Do not press the Contact Arm against the object.**

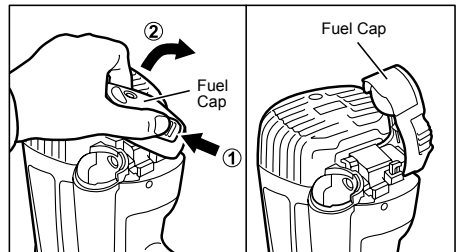

- 1 Press the Latch, then pull the Fuel Cap.

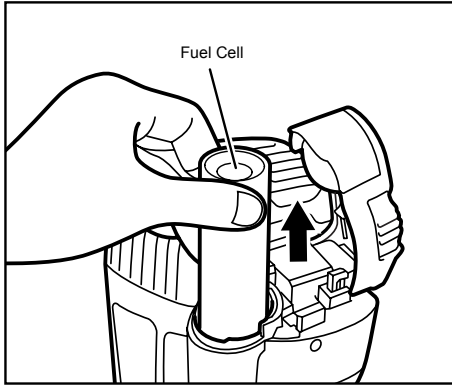

- ② Grab and remove the used Fuel Cell.
- ③ Set the new Fuel Cell.
(See Page 14 for the setting method)

REPLACING THE BATTERY

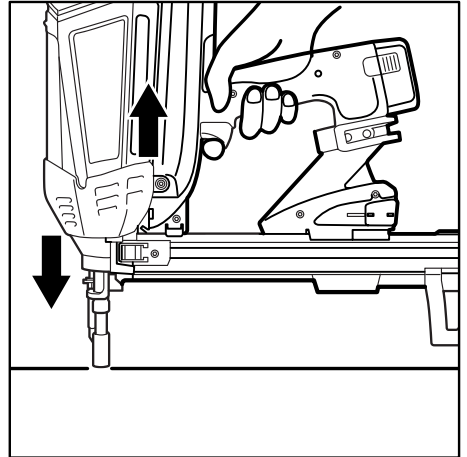

If the Battery is low, the red LED of the tool will be turned on.



WARNING

- Be sure to remove the Fuel Cell.
- Release the Trigger.
- Do not press the Contact Arm against the object.

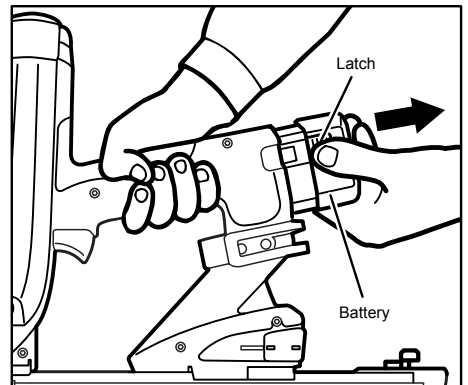

- ① Firmly holding the grip, press the latches on both sides of the Battery to remove it.

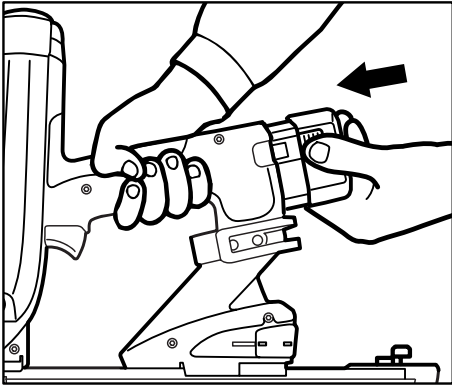

- ② Install the newly charged Battery into the Housing until it has clicked.
(See Page 13 for the charging method)
- ③ Install the Fuel Cell.
(See Page 14 for the Installation method)

7. MAINTAIN FOR PERFORMANCE

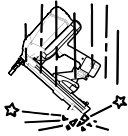

1. **HANDLE THE TOOL WITH CARE**
Never drop, collide or hit the tool against a hard material. It may be deformed, cracked or damaged.



2. **DO NOT TRIGGER THE TOOL WITH NO PINS LOADED**
If you repeatedly operate the tool with no pins loaded, the durability of each section will be reduced.



3. **DO NOT LUBRICATE THE TOOL**
Never lubricate the Tool because it will cause problems.



4. **INSPECT THE TOOL PERIODICALLY**
In order to maintain the performance of the tool, clean and inspect the tool periodically. To have it inspected, contact your nearest distributor.

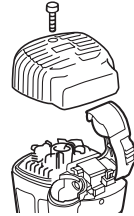

5. **CLEAN THE AIR FILTER**
Clean the Air Filter every other day. Open the cylinder cap unit with a regular screwdriver, and clean it with Compressed air.



CAUTION

- Be sure that the tool has been cooled down.

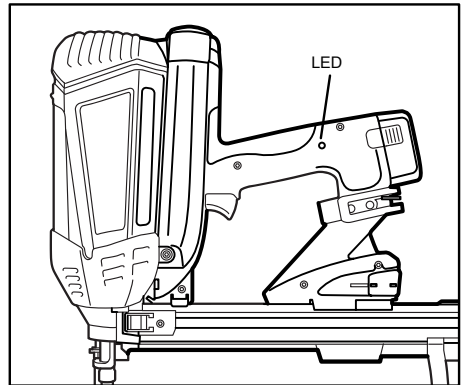

6. **MAINTENANCE LED INDICATOR**
When the indicator light starts blinking, it is time to clean the tool. Bring the tool to the Powers Fasteners authorized service center for cleaning inside of the tool.

7. PRODUCTION YEAR INDICATION

This product indicates production number at the lower part of the grip. The first 2 digits of the number from left indicates the product year.

(Example)

0 9 8 2 2 6 0 3 5 D

└
Year 2009

8. STORING

- 1 When not in use for an extended period, apply a thin coat of the lubricant to the steel parts to avoid rust.
- 2 Do not store the tool in a cold weather environment. Keep the tool in a warm area.
- 3 When not in use, the tool should be stored in a warm and dry place. Keep out of reach of children.
- 4 All quality tools will eventually require servicing or replacement of parts because of wear from normal use.

SLEEP-MODE

To save battery life this tool is equipped with Sleep-Mode function. If the battery is left in the tool for more than 24 hours, the tool will go into "Sleep-Mode" (the tool will not function.)

To restart the tool remove then reinstall the battery. This will allow the tool to function normally.

9. TROUBLE SHOOTING/REPAIRS

- 1 The repairs shall be carried out only by the Powers Fasteners authorized service center.
- 2 The tool is provided with a pin remover to ensure that the jamming pins can be easily removed.



WARNING

- Remove the Fuel Cell, followed by the Battery.
Procedure

- 1 Remove the Fuel Cell, followed by the Battery.
- 2 Remove the pins remaining in the magazine.

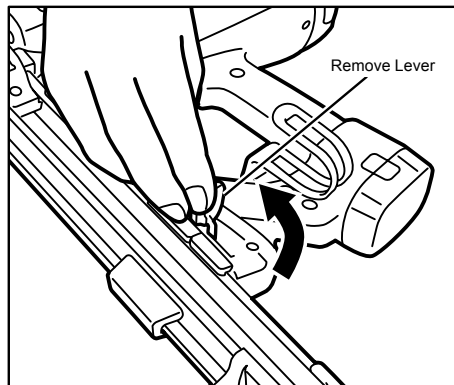

- 3 Pull up the Remove Lever and remove the Magazine from the tool.

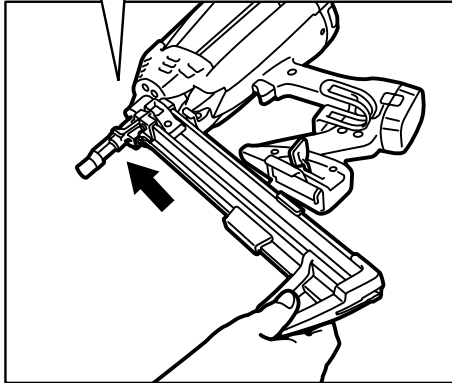
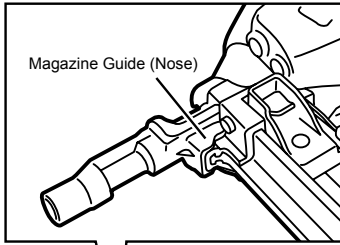

④ At this point, the jammed pin should fall out. If the jammed pin does not fall out, carefully remove the pin taking care not to damage the Nosepiece. After you have removed the jammed pin, take the following steps to assemble the Magazine into the tool.

⑤ Insert the front of the Magazine into the Magazine Guide (Nose).

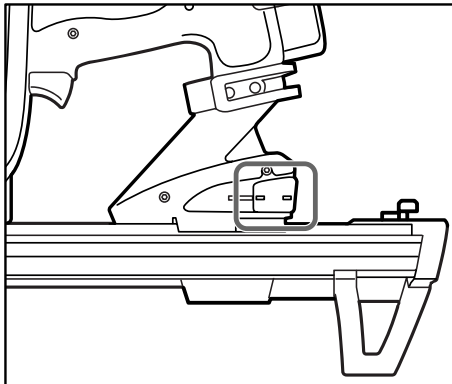

⑥ Make sure to align the Magazine with the Magazine Holder with no gap. Push the Remove Lever until it clicks.

- The content of this manual might be changed without notice for improvement.
 - Le contenu de ce manuel est sujet a modification sans preavis a des fins d'amelioration.
 - El contenido de este manual puede ser cambiado sin noticia previa para mejoramiento.
-
- The specifications and design of the products in this manual will be subject to change without advance notice due to our continuous efforts to improve the quality of our products.
 - Les caractéristiques et la conception des produits mentionnés dans ce manuel sont sujettes à des modifications sans préavis en raison de nos efforts continus pour améliorer la qualité de nos produits.
 - Las características y la concepción de los productos mencionados en este manual están sujetas a modificaciones sin preaviso debido a nuestros esfuerzos continuos para mejorar la calidad de nuestros productos.



GN12169
110426-00/00

