



FIVE STAR PRODUCTS, INC.

www.fivestarproducts.com
(800) 243-2206

DESIGN-A-SPEC™ GUIDELINES FIVE STAR NOVOLAC STRUCTURAL CONCRETE

CONTENTS

▶	PART A - GENERAL CONDITIONS
▶	PART B - MATERIAL SPECIFICATIONS
▶	PART C -PREPARATION
▶	PART D - APPLICATION
▶	PART E - FINISHING AND CURING
▶	PART F - EXTREME WEATHER CONDITIONS

This document is provided for informational purposes only and as a general guideline for consideration by contractors and engineers. While every reasonable effort has been made to ensure that this information is accurate and authoritative, Five Star Products does not warrant the accuracy or completeness of this information, or for its appropriateness for any particular purpose. The user of this document remains solely responsible for the specification of all methods, materials and practices.

PART A - GENERAL CONDITIONS - SPECIALTY CONCRETE REPAIR

1.01 SCOPE

The work covered by this document consists of furnishing all equipment, materials, labor and performing all operations required for concrete repairs as directed by the engineer or owner.

1.02 QUALITY ASSURANCE

- A. The manufacturer shall have been in the business of manufacturing similar products for over ten years, maintain a strict quality assurance program, offer technical services and provide a representative at the jobsite for product training, prior to product installation, upon written request.
- B. The contractor shall submit to the engineer, or owner, at least three job references where the contractor has successfully completed similar applications.

1.03 DELIVERY, STORAGE AND HANDLING

- A. All materials shall be delivered to the jobsite in their original, unopened packages, clearly labeled with the manufacturer's identification, printed instructions and batch code.
- B. Store and condition the specified product as per the appropriate product data sheet.
- C. For handling instructions, refer to the Material Safety Data Sheet.

1.04 PROJECT/SITE CONDITIONS

Refer to PART C - PREPARATION, ENVIRONMENTAL CONDITIONS, or contact the manufacturer directly for any physical or environmental limitations required by the product.

1.05 MEASUREMENT AND PAYMENT

- A. Measurement for concrete repairs shall be on a cubic foot/square foot (liter/square meter) basis of material in place.
- B. Payment for concrete repairs shall be at the unit price bid on a cubic foot/square foot (liter/square meter) basis. This payment shall constitute full compensation for all labor, materials, tools, equipment and other items as necessary to complete the work as described in the contract documents. Progress payments will be made on the percentage of the work satisfactorily completed during each payment period in accordance with the provisions of the contract documents.

PART B - MATERIAL SPECIFICATION - SPECIALTY CONCRETE REPAIR**2.01 MATERIALS**

- A. The concrete repair material shall be a highly chemical resistant, epoxy novolac based pre-packaged mortar containing thermosetting resins and inert aggregate fillers. The manufacturer shall be ISO 9001 certified and have at least ten years experience in the manufacture of concrete repair materials. The manufacturer shall offer technical services and provide a representative at the jobsite for product training prior to product installation upon five days advance notice.
- B. The epoxy novolac repair material shall meet all the following typical performance criteria when cured at 73°F (23°C):

1.	Compressive Strength, ASTM C 109	
	1 Day	16,000 psi (110MPa)
	7 Days	17,000 psi (117 MPa)
2.	Bond Strength, ASTM C 882	
	7 Days	Concrete Failure
3.	Flexural Strength, ASTM C 580	6,000 psi (38.7 MPa)
4.	Tensile Strength, ASTM C 307	2,100 psi (14.5 MPa)
5.	Coefficient of Expansion, ASTM C 531	15 x 10 ⁻⁶ in/in/°F
		29 x 10 ⁻⁶ mm/mm/°C

The data shown above reflect typical results based on laboratory testing under controlled conditions. Reasonable variations from the data shown above may result in the field. Test methods are modified where applicable.

- C. An acceptable product which meets these criteria is:

Five Star Novolac Structural Concrete

As manufactured by Five Star Products, Inc., Fairfield, CT 06824 (203) 336-7900.

- D. Subject to meeting the performance criteria stated above, other products may be formally submitted to the engineer for approval up to three days prior to the bid date. All requests for approval shall contain certified test data verifying conformance with this specification. Three references of successfully completed projects of similar nature and scope of the work detailed in this specification shall be provided, as well as a minimum ten year history of use in the industry. The testing laboratory shall certify to any modifications made to the tests performed and provide details of modifications.

2.02 AGGREGATE EXTENSION

- A. For pours greater than six inches in depth, the epoxy novolac repair material may be extended with a clean dried coarse aggregate meeting the requirements of ASTM C 33. Coarse aggregate must be completely dry prior to use.

PART C – PREPARATION - SPECIALTY CONCRETE REPAIR

3.01 CONCRETE SURFACES

- A. Completely remove all loose, delaminated and weak concrete, oil, grease, laitance and other contaminants. Prepare concrete using acceptable mechanical means and concrete cleaners and degreasers as necessary to obtain clean, sound and rough surfaces. Coarse aggregate shall be exposed.
- B. The edges of the repair shall be vertical and have a rough profile. Avoid abrupt changes in depth.
- C. The perimeter of the repair shall be kept to a simple shape. Avoid reentrant corners.

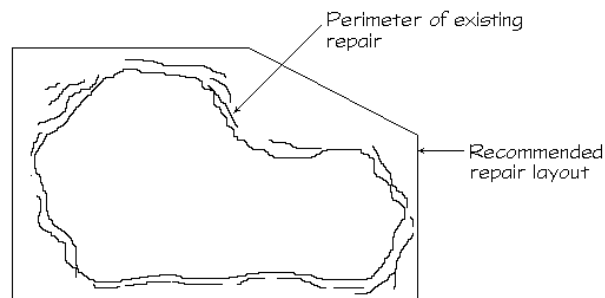

- D. All cracks shall be brought to the attention of the engineer and a determination made of whether the cracks are subject to movement. The cracks shall be repaired as directed prior to application of the repair material.
- E. All existing joints shall be maintained. New joints, if any, shall be installed as detailed on the drawings.
- F. Concrete surfaces must be completely dry prior to placement of epoxy novolac repair material.

[For more detailed information, refer to the following source: "Surface Preparation Guidelines For The Repair of Deteriorated Concrete Resulting From Reinforcing Steel Oxidation", Report of International Concrete Repair Institute, March 1995.]

3.02 REINFORCEMENT

- A. All reinforcing steel that has lost bond with the concrete or has more than one-half of its circumference exposed shall be undercut by at least 3/4 inch (18 mm) or two times the maximum aggregate size.

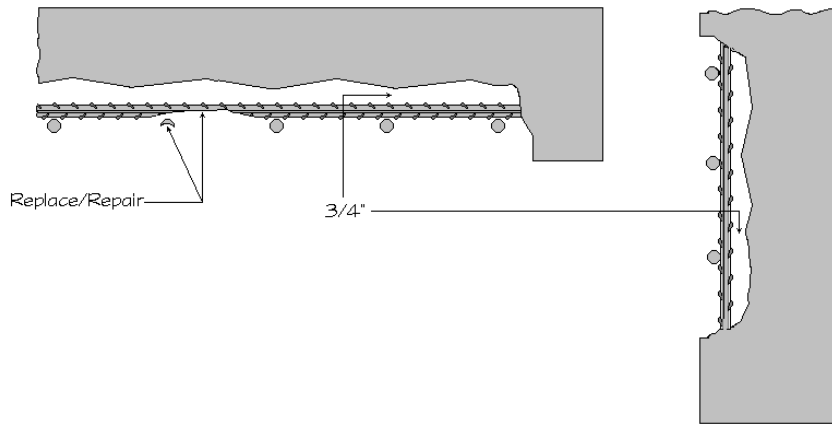

- B. All reinforcement shall be rigidly secured and supported.
- C. If more than 20% of the diameter of a reinforcing bar has been deteriorated, the bar will require replacement or will need to be spliced as directed by the engineer.
- D. All exposed reinforcing steel shall be free of all loose scale and rust, and other contaminants.
- E. The minimum cover over reinforcement shall be in accordance with job specifications or 3/4 inch (18 mm), whichever is greater.

3.03 FORMWORK

- A. Formwork shall be constructed of rigid nonabsorbent materials, securely anchored, watertight and strong enough to resist forces developed during placement.
- B. Formwork shall be coated with a form release agent such as paste wax or plastic sheeting.
 Caution: Care should be taken not to contaminate concrete surfaces where bond is required.

3.04 ENVIRONMENTAL CONDITIONS

- A. Condition and maintain all materials to between 70°F and 80°F (21°C and 27°C), and surfaces to between 60°F and 90°F (15°C and 32°C). Shade from direct sunlight as necessary.
[When faster strength gain is required at low temperatures, or longer working time is required at high temperatures, revise the temperature range above as appropriate and refer to detailed conditioning procedures for Cold Weather or Hot Weather Repairs, PART F – EXTREME WEATHER CONDITIONS.]

3.05 EQUIPMENT AND MATERIALS

- A. All necessary tools, equipment and materials shall be in good condition and as close as possible to area being repaired.
- B. Appropriate clothing and safety equipment shall be worn to avoid breathing dust and prevent eye and skin contact with both dry and mixed repair materials.

3.06 MIXING

Mortar Mixer (Stationary Barrel with Moving Paddles)

- A. Always use at least one-half the capacity of mixer when mixing repair material.
- B. Combine Component A (resin) and Component B (hardener) by pouring Component B (hardener) into pail containing Component A (resin). Mix thoroughly by hand with a paddle or by slow speed mixer until a uniform color is obtained (no streaks); **avoid air entrapment**. Immediately pour all mixed liquids into mortar mixer. While mixing at a slow speed (approximately 20RPM), slowly add Component C (aggregate) without delay and mix only until aggregate is completely wet.
- C. Do not mix more material than can be placed within the working time of the repair material

PART D – APPLICATION - SPECIALTY CONCRETE REPAIR

4.01 PLACEMENT PROCEDURES HAND APPLIED

TROWEL - HORIZONTAL

[For horizontal repair areas with limited reinforcement.]

- A. Substrate shall be completely dry prior to epoxy novolac repair material placement.
- B. Work repair material into roughened substrate completely filling all pores and voids. Whenever possible, place repair material full depth from one side of the repair to the other. Where this is not practical, placement shall be continuous to prevent cold joints.
- C. Once desired level is achieved, screed repair material using a sawing motion and steel trowel finish to desired texture. A light solvent coat on steel trowel will facilitate final finishing.

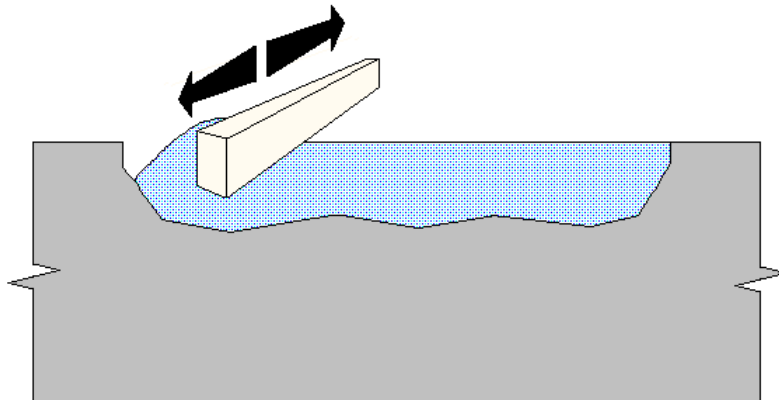

PART D – APPLICATION - SPECIALTY CONCRETE REPAIR

4.01 PLACEMENT PROCEDURES

FORM AND POUR

[For larger vertical and horizontal repairs.]

- A. Chutes, tremies, buggies, buckets or similar equipment may be required for material placement. Provide adequate access to allow continuous placement to avoid air entrapment. Only use vibration sparingly on formwork where absolutely necessary. Vibrators shall not be used to move repair material laterally.
- B. For vertical repairs, material shall be poured in formwork in a manner to avoid segregation. Do not allow material to fall freely over reinforcement or other embedded materials.
- C. For horizontal repairs, work repair material into roughened substrate to completely fill all pores and voids. Material shall be poured continuously from one side of repair area to the other starting at the lowest elevation. When placing in layers on large pours, each horizontal layer shall extend repair width. Placement must be continuous to prevent cold joints. Place and consolidate in a manner to avoid segregation.
- D. Continue placement until repair area is completely filled.

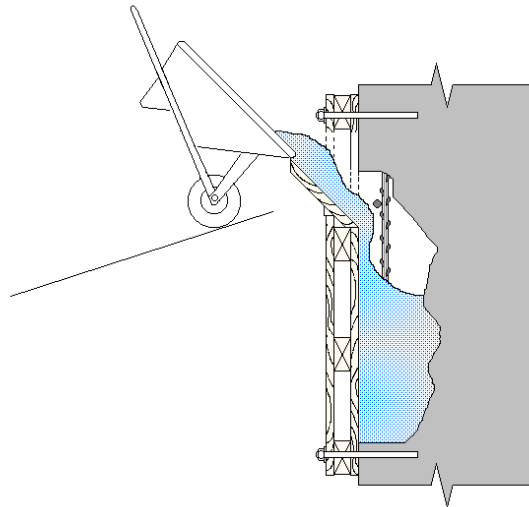

REFERENCE

PART D – APPLICATION - SPECIALTY CONCRETE REPAIR

4.01 PLACEMENT PROCEDURES OVERLAYS

- A. Substrate shall be completely dry prior to placement of epoxy novolac repair material.
- B. Work repair material into substrate to completely fill all pores and voids. Uniformly place overlay to a slightly overfilled elevation. Level and consolidate by screeding using a sawing motion and final finish using steel trowel. A light solvent coat on steel trowel will facilitate final finishing.
- C. Placement shall be continuous to prevent cold joints.

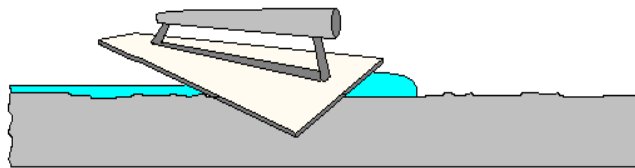

PART E – FINISHING AND CURING - SPECIALTY CONCRETE REPAIR

5.01 FINISHING

A. Final finishing is best accomplished using a steel trowel – a light solvent coat will facilitate final finishing.

5.02 CURING

- A. Epoxy novolac repair material shall be cured as recommended by the manufacturer.
- B. Epoxy novolac repair material shall be protected from freezing, hydrostatic pressure and vibration as recommended by the manufacturer.

PART F – EXTREME WEATHER CONDITIONS - SPECIALTY CONCRETE REPAIR

6.01 COLD WEATHER REPAIRS

[Low temperatures decrease flow, delay set and strength development of epoxy products. The procedures below may compensate for these conditions.]

- A. Materials shall be conditioned so that placed material is between 70°F and 90°F (21°C and 32°C). Due to the mass of palletized material, up to 72 hours of conditioning may be required. Store all epoxy novolac repair material components (including aggregate) in an enclosed heated area where required.
- B. All surfaces in contact with epoxy novolac repair material shall be preconditioned and maintained between 60°F and 90°F (16°C and 32°C) for at least 24 hours.
- C. When necessary, heating shall be accomplished by indirect exposure. Heated enclosures must be windproof and weatherproof. Heaters shall not be permitted to unevenly heat concrete. *Caution: Exhaust gases of unvented heaters may contaminate or cause carbonation of concrete within the enclosed environment.*
- D. Grout temperature shall be maintained above 60°F (16°C) until grout reaches required strength.
- E. Gradually allow epoxy novolac repair material temperature to cool to ambient to avoid thermal shock.
- F. For surface temperatures below 60°F (16°C), contact manufacturer.

PART F – EXTREME WEATHER CONDITIONS - SPECIALTY CONCRETE REPAIR

6.01 HOT WEATHER REPAIRS

[High temperatures accelerate set, decrease working time, and accelerate strength gain of epoxy products. The procedures below may compensate for these conditions.]

- A. Materials shall be pre-conditioned so that placed epoxy novolac repair material is between 70°F and 90°F (21°C and 32°C). Due to the mass of palletized material (aggregate), up to 72 hours of pre-conditioning may be required. Store all grout components (including aggregate) in a shaded area out of direct sunlight. Bags of ice may be placed around containers of resin and hardener components to facilitate cooling.
- B. All surfaces in contact with epoxy novolac repair material shall be preconditioned and maintained between 60°F and 90°F (16°C and 32°C) for at least 24 hours.
- C. Shade application areas from direct sunlight or pour grout when temperatures are lower in early morning or night. When other cooling methods are used, extreme caution shall be taken to insure all surfaces in contact with grout are completely dry before grouting.
- D. Epoxy novolac repair material shall remain shaded and protected for at least 24 hours after placement.
- E. For surface temperatures above 90°F (32°C), contact manufacturer.