

Gripstay™ Anchors, Channels & Ties

362 Gripstay™ Channel

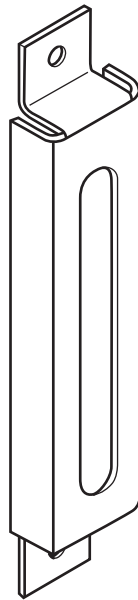

362 Gripstay™ Channel

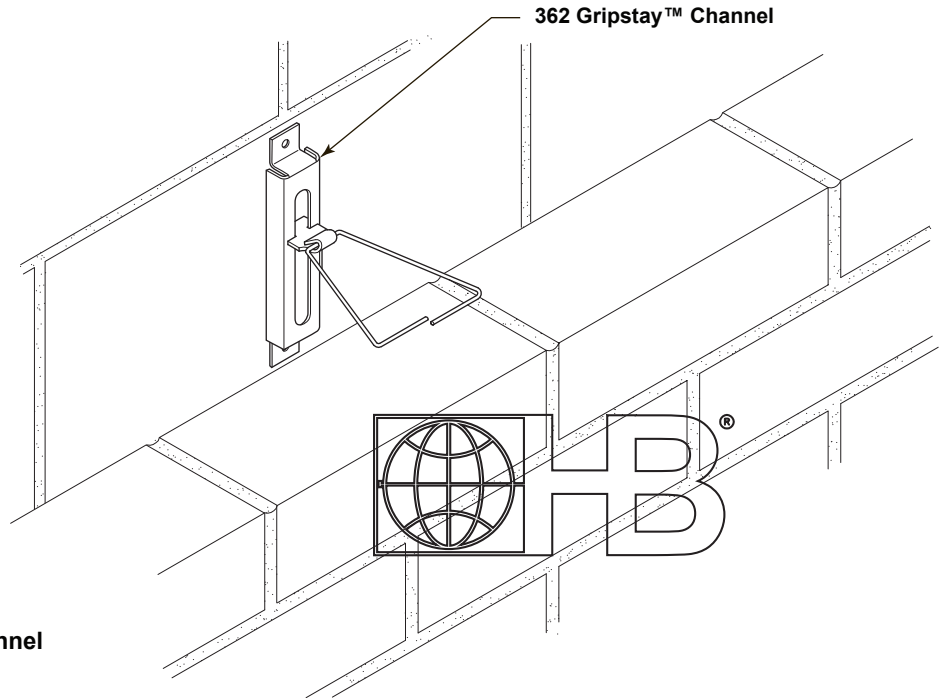

DRAWINGS FOR ILLUSTRATIVE PURPOSES ONLY

The **362 Gripstay™ Channel** is furnished with integrally formed end tabs for attachment to masonry, and will accept any Gripstay™ Anchor for masonry or stone.

Sheet Metal (Carbon Steel):
ASTM A1008/A1008M

Zinc Coating:

Hot-Dip Galvanized: **ASTM A153/A153M-B2 Class B** (sheet metal ties and anchors Hot-Dip Galvanized after fabrication)

Note: Hohmann & Barnard will certify to a minimum of 2.0 oz/ft²

Sheet Metal (Stainless Steel):

ASTM A666, ASTM A480/ASTM A480M, and ASTM A240/A240M - AISI Type 304 or Type 316

U.S. Patent No. 5,063,722

Dimensions:

Thickness: 14 gauge, 12 gauge, or 11 gauge

Hole size: 5/16"

Length: 6 1/4" o.a. w/ built-in end clips for attachment to masonry

Finishes:

Hot-Dip Galv. Stainless Steel: Type 304 Type 316

Note: Hohmann & Barnard recommends Stainless Steel for maximum protection against corrosion.

Thickness:

14 gauge

12 gauge

11 gauge

IMPORTANT: Since each construction project is unique, the appropriate selection and use of any product contained herein must be determined by competent architects, engineers and other appropriate professionals who are familiar with the specific requirements of the project in question.