

# Gripstay™ Anchors, Channels & Ties

## 360 Gripstay™ Channel

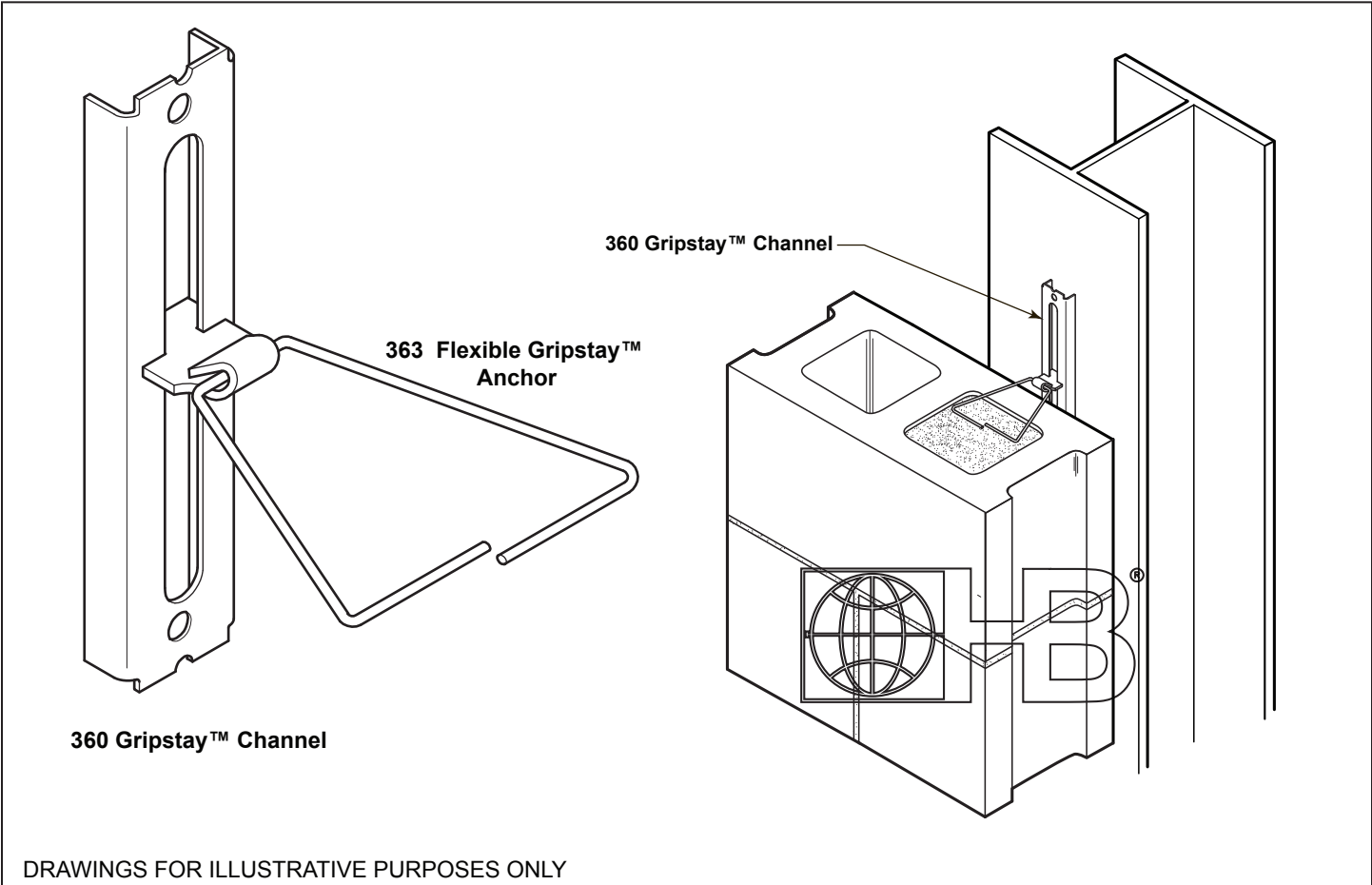

DRAWINGS FOR ILLUSTRATIVE PURPOSES ONLY

The **360 Gripstay™ Channel** welds onto steel web or flange to accept any type of Gripstay™ Anchor.

**Sheet Metal (Carbon Steel):**

**ASTM A1008/A1008M**

Zinc Coating:

Mill Galvanized: **ASTM A653/A653M** (0.6 oz/ft<sup>2</sup>)

Hot-Dip Galvanized: **ASTM A153/A153M**-B2 Class B (sheet metal ties and anchors Hot-Dip Galvanized after fabrication)

Note: Hohmann & Barnard will certify to a minimum of 2.0 oz/ft<sup>2</sup>

**Sheet Metal (Stainless Steel):**

**ASTM A666, ASTM A480/ASTM A480M, and ASTM A240/A240M - AISI Type 304 or Type 316**

U.S. patent No. 5,063,722

**Dimensions:**

Thickness: 14 gauge, 12 gauge, or 11 gauge

Length: 7 ½" (5 ½" vertical adjustability)

Hole size: 5/16"

**Finishes:**

Mill Galvanized

Hot-Dip Galv. | Stainless Steel:  Type 304  Type 316

**Thickness:**

14 gauge

12 gauge

11 gauge

**Note: Hohmann & Barnard recommends Stainless Steel for maximum protection against corrosion.**

**IMPORTANT:** Since each construction project is unique, the appropriate selection and use of any product contained herein must be determined by competent architects, engineers and other appropriate professionals who are familiar with the specific requirements of the project in question.