

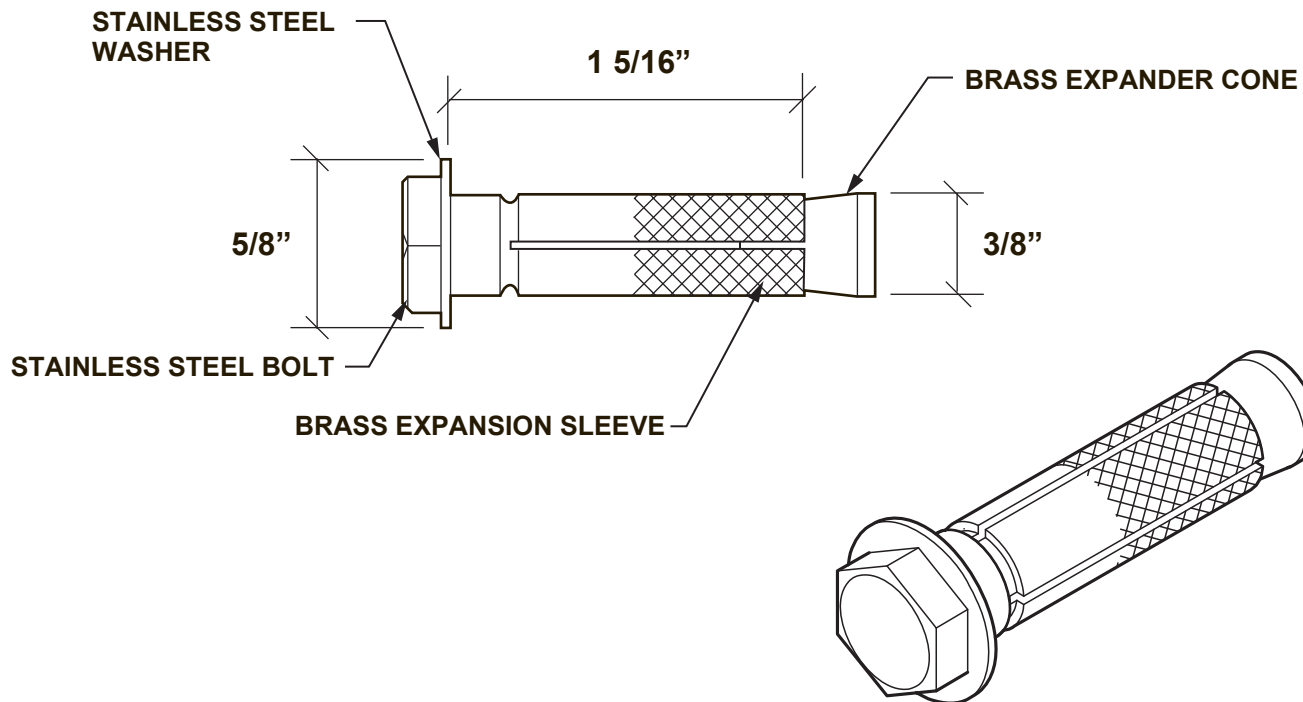

HOHMANN & BARNARD, INC.
A MiTek - BERKSHIRE HATHAWAY COMPANY

523 Brass Expansion Bolt



DRAWINGS FOR ILLUSTRATIVE PURPOSES ONLY

523 Brass Expansion Bolt

The BL-523 masonry fastener is for fastening anchors to concrete, block, brick and into mortar joints.

Materials:

- Internal Bolt: Type 304 Stainless Steel
- Stainless Steel Washer: Type 18-8 Stainless Steel
- Knurled Expansion Sleeve: Brass 260 Alloy
- Expander Cone: Brass 260 Alloy

Sold only in conjunction with related anchors.

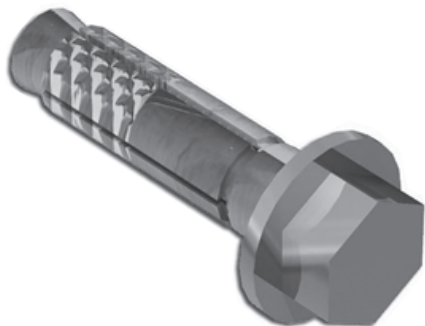

Ultimate Structural Values* (Tension):

- C-90 CMU Block (Shell) 1720#
- C-90 CMU Block (Rib) 2015#
- Brick Masonry 1550#
- Brick/CMU mortar joint 1435#
- Concrete (3000psi.) 1785#

* Full 1" Embedment. * The ultimate structural values listed above are ultimate load capacities, which should be reduced by a minimum safety factor of 4.0 or greater to determine the allowable working load.

Dimensions:

- ANSI drill bit size: 3/8"Ø
- Fixture clearance hole: 7/16"Ø
- Internal bolt size: 1/4"Ø - 20
- Head height: 1/4"
- Washer O.D.: 3/4"

IMPORTANT: Since each construction project is unique, the appropriate selection and use of any product contained herein must be determined by competent architects, engineers and other appropriate professionals who are familiar with the specific requirements of the project in question.

HOHMANN & BARNARD, Inc.
30 Rasons Court | Hauppauge, NY 11788
CORPORATE HEADQUARTERS
T: 800.645.0616 F: 631.234.0683
www.h-b.com

Branch/Subsidiary Locations:
ALABAMA - ILLINOIS - MARYLAND
NEW YORK - PENNSYLVANIA - TEXAS
UTAH - CANADA

© HOHMANN & BARNARD, INC. - 2014