

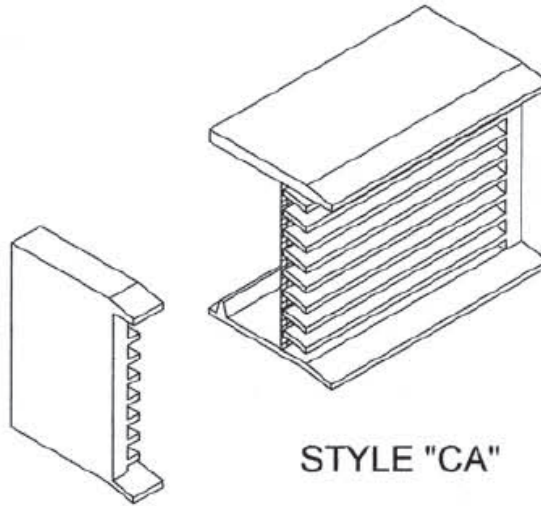

HOHMANN & BARNARD, INC.
A MiTek - BERKSHIRE HATHAWAY COMPANY

Aluminum Brick Vents

Cast Aluminum Brick Vent - Style "CA"



DRAWINGS FOR ILLUSTRATIVE PURPOSES ONLY

Style "CA" Brick Vent Description:

- One piece molded cast aluminum
- Minimum .125" thick, 4" deep
- Rear water stop
- Load bearing
- Overlapping blades
- Continuous bottom weepage

Note: Can be equipped with operable damper and ducts

Free Area Chart

Vent Size	Free Area
16 1/2" W x 2 3/8" H	26%
16 1/2" W x 3 3/4" H	34.5%
16 1/2" W x 4 3/4" H	38%
16 1/2" W x 5 3/4" H	30%
16 1/2" W x 7 3/4" H	38%
16 1/2" W x 9 3/4" H	38%
16 1/2" W x 11 3/4" H	38%
16 1/2" W x 15 3/4" H	38%

NOTE: • Less than 16" wide reduces free area by 1%
• Greater than 16" wide increases free area by 1%.

H&B manufactures aluminum brick vents from a minimum of 41% pre-consumer and 23% post-consumer recycled material.

Model Number

- CA 825
- CA 847
- CA 808
- CA 123
- CA 124
- CA 125
- CA 128
- CA 162
- CA 1604
- CA 164
- CA 166
- CA 168

W x H (Nominal)

- 8 1/8" x 2 1/4"
- 8 1/4" x 4 15/16"
- 8" x 7 7/8"
- 12" x 2 3/4"
- 12" x 3 1/2"
- 12" x 5"
- 12" x 7 3/4"
- 16 1/2" x 2 3/8"
- 16" x 4"
- 16" x 4 15/16"
- 16" x 6"
- 16" x 7 3/4"

NOTE: Cast aluminum vents are standard in mill finish and do not include mortar ribs (also available in baked enamel at an extra charge)

HOHMANN & BARNARD, Inc.
30 Rasons Court | Hauppauge, NY 11788
CORPORATE HEADQUARTERS
T: 800.645.0616 F: 631.234.0683
www.h-b.com

Branch/Subsidiary Locations:
ALABAMA - ILLINOIS - MARYLAND
NEW YORK - PENNSYLVANIA - TEXAS
CANADA

© HOHMANN & BARNARD, INC. - 2012