

PTA Series Partition Top Anchors

PTA 310 HS (High Strength)

Heavy-Duty for Hurricane Velocity Wind Loads.

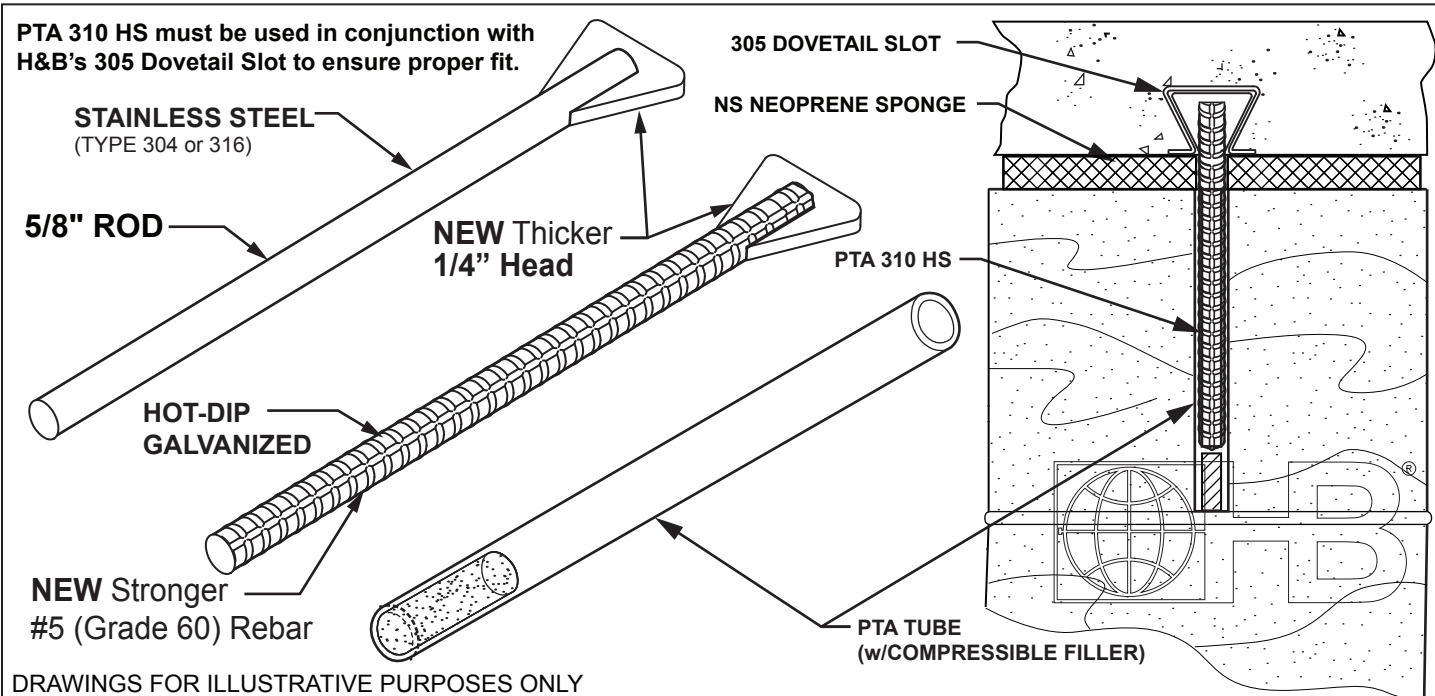

PTA 310 HS provides lateral shear resistance at the upper limit of masonry walls. They permit vertical deflection of the slab above, without transferring compressive loads to the masonry wall below. PTA Series Anchors are suitable for construction using steel or concrete. PTA Tube with expansion filler is placed over rod anchor, which has been attached to concrete or steel. The vertical joint is then filled with mortar, fully surrounding the tube.

- Larger diameter rod for higher working loads and resistance to larger positive/negative lateral forces.
- 1/4" thick head insures anchor is engaged perpendicular to the dovetail slot, not free to rotate and disengage.
- Integral welded rod to head design removes the rotation of the anchor in the expansion joint, and transfers loads directly to concrete and dovetail slot
- Fully welded on both sides of dovetail head, not spot welded.
- Dovetail head is keyed to receive 5/8" diameter rod (not welded to the side of the head) for symmetrical, not asymmetrical, loading.

Sheet Metal (Carbon Steel):

ASTM A1008/A1008M/A (Cold-rolled)

ASTM A1011/A1011M (Hot-rolled, pickled and oiled)

Finishes - Sheet metal (Carbon-Steel):

Hot-Dip Galvanized - ASTM A153/A153M-B2 class B (sheet metal ties and anchors hot-dip galvanized after fabrication).

Note: Hohmann & Barnard will certify to a minimum zinc coating of 2.0 oz./ft.²

Sheet Metal (Stainless Steel): ASTM A 666, ASTM A480/480M, and ASTM A240/A240M - AISI Type 304 or 316

Rod (#5 rebar): Hot-Dip Galvanized - ASTM A153/A153M-B2

Rod (5/8"): Stainless Steel Type 304 - ASTM A582/A582M

PTA Tube:

Manufactured from Clear Butyrate. Tested in conformance with ASTM D542, ASTM D149, ASTM D696 and ASTM D257.

Dimensions:

Hot-Dip Galvanized: #5 (grade 60) rebar rod, 1/4" thick dovetail head.

Stainless Steel: 5/8" Rod, 1/4" thick dovetail head.

Other diameters and dimensions available.

Length:

7 1/2" Rod/Rebar Standard Custom _____

Finishes:

- Hot-Dip Galvanized (#5, grade 60, rebar rod)
- Stainless Steel Type 304 (5/8" rod)
- Stainless Steel Type 316 (5/8" rod)

Note: H&B recommends Stainless Steel for maximum protection against corrosion.

Note: NS Neoprene sponge also available. Submittal sheet available for download from h-b.com or upon request.

IMPORTANT: Since each construction project is unique, the appropriate selection and use of any product contained herein must be determined by competent architects, engineers and other appropriate professionals who are familiar with the specific requirements of the project in question. This drawing and/or data sheet is the confidential and proprietary information of Hohmann & Barnard, Inc. and is not to be reproduced, copied or disclosed, in whole or in part, without the prior written consent of H&B.