

HOHMANN & BARNARD, INC.
a MiTek company

Flashing and Reglets

T2 - Termination Bar

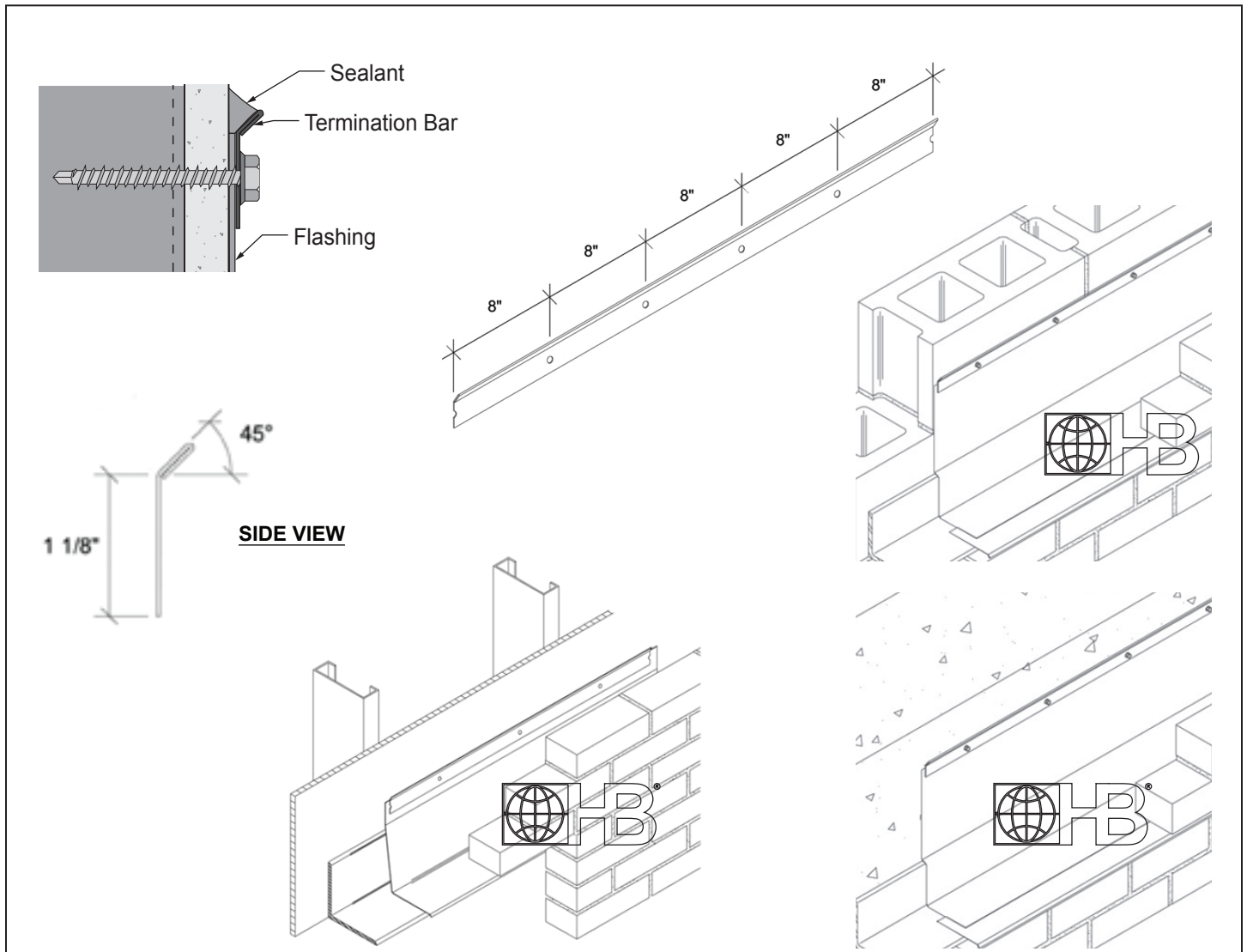

DRAWINGS FOR ILLUSTRATIVE PURPOSES ONLY

T2 - Termination Bar

Used at top of flashing to mechanically secure it to backup. Compatible with all H&B Surface-Mount membrane and copper-laminate flashings.

NOTE: Available with optional Foam-Tite Seal™ to aid in inhibiting moisture infiltration. A factory-installed foam strip helps to seal small voids occurring between the termination bar and irregular substrate surfaces, while offering protection against water penetration due to sealant deterioration.

NOTE: H&B recommends termination bars be fastened 8" o.c. (Metal term bars can be fastened 16" o.c. for metal stud backup)

Product: (Type 304 Stainless Steel, 26 Gauge)

- T2
- OPTIONAL: T2-FTS (Foam-Tite Seal™)

Dimensions:

- 26 ga. x 1 1/2" x 8' long
- Has a 3/8" flange on top for easy caulking
- 1/4" holes spaced 8" o.c.

IMPORTANT: Since each construction project is unique, the appropriate selection and use of any product contained herein must be determined by competent architects, engineers and other appropriate professionals who are familiar with the specific requirements of the project in question. This drawing and/or data sheet is the confidential and proprietary information of Hohmann & Barnard, Inc. and is not to be reproduced, copied or disclosed, in whole or in part, without the prior written consent of H&B.

HOHMANN & BARNARD, Inc.
30 Rasons Court | Hauppauge, NY 11788
CORPORATE HEADQUARTERS
T: 800.645.0616 F: 631.234.0683
www.h-b.com

Branch/Subsidiary Locations:
ALABAMA - ARIZONA - ILLINOIS
MARYLAND - NEW YORK
PENNSYLVANIA - TEXAS - UTAH
CANADA

© 2013-2016 MiTek®