

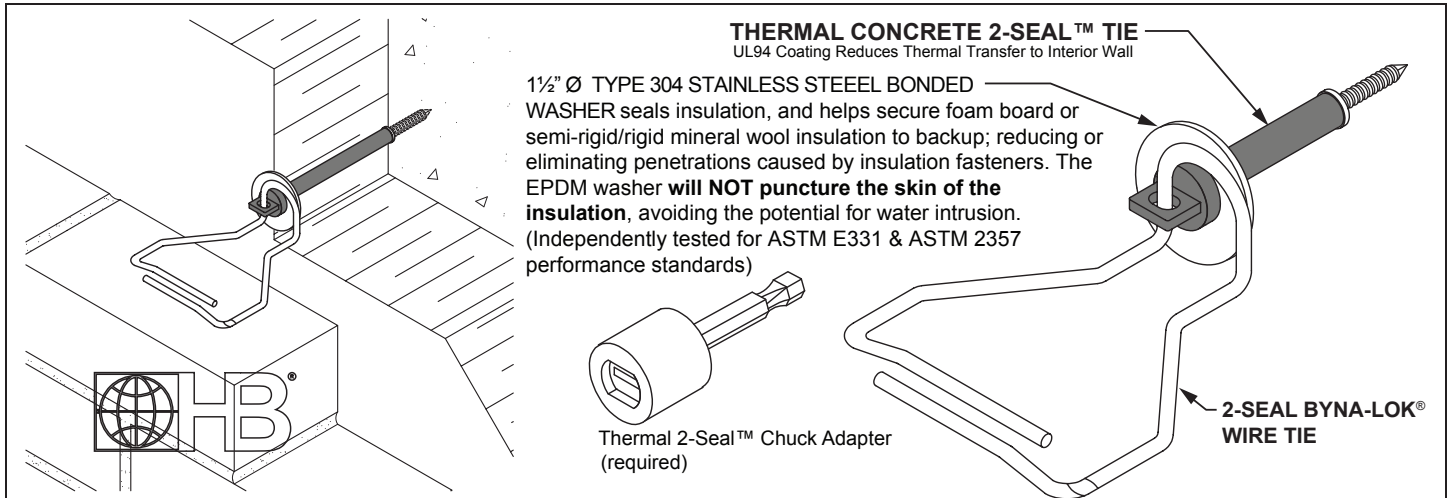

Veneer Anchors

Thermal Concrete 2-Seal™ Tie

Adjustable Thermal Veneer Anchor



THERMAL CONCRETE 2-SEAL WITH 2-SEAL WIRE TIE (WORKING LOAD*)

CAVITY	0" OFFSET	5/8" OFFSET	1 ¼" OFFSET	TEST
6 ½"	573#	N/A	206#	TENSION
6 ½"	402#	N/A	166#	COMPRESSION

* WORKING LOAD DETERMINED AT .05" DEFLECTION

Tests were completed for 4 ½" insulation with 2" air cavity.

Pullout values assume wire 2-Seal Byna-Lok Wire Tie is fully engaged into 2-Seal Tie with "0" eccentricity.

SCREW PULL-OUT (1 ¼" minimum embed)

CONCRETE	C-90 Hollow Block
810# (average ultimate load)	700# (average ultimate load)

DRAWINGS FOR ILLUSTRATIVE PURPOSES ONLY

H&B RECOMMENDS 16" X 16" SPACING

Thermal Concrete 2-Seal™ Tie is an innovative single screw veneer tie suitable for use with concrete, CMU, wood stud or brick backup. The anchor is **FULLY COATED** with a proprietary material tested in accordance to **UL94 (The Standard for Flammability of Plastic Materials)**. The material reduces thermal transfer through rigid insulation.

- Features a screw with alternating threads and two factory-installed EPDM sealing washers
- Requires a pre-drilled 5/32" (4 mm) hole to a depth of 2" (51 mm) into concrete, CMU, or masonry backup.
- Available for 5/8" - 4½" wallboard + insulation combination

The 2-Seal Byna-Lok Wire Tie is adaptable for seismic zones with the simple addition of 9 gauge or 3/16" continuous wire (just drop into the integral track formed by the swaged, overlapping legs of the wire tie.)

Barrel (Stainless Steel): ASTM A580/A580M - AISI Type 304

Screw (Carbon Steel): ASTM A510 (Carbon Steel)

ASTM C954 (1000-hour polymer coating)

Coating: ASTM D792 (density), ASTM D785 (Hardness), ASTM D955 (Mould Shrinkage), ASTM D638 (Tensile Strength), ASTM D790 (Flexural Strength), ASTM D256 (Izod Impact Strength), ASTM D1525 (Softening Temp) ASTM D648 (Heat Distortion Temp.), UL94 (Flammability)

Wire (Carbon Steel): Prefabricated from cold-drawn steel wire conforming to **ASTM A1064/A1064M**

Tensile Strength - 80,000 p.s.i. | Yield Point - 70,000 p.s.i. minimum

Zinc Coating: Hot-Dip Galvanized after fabrication:

ASTM A153/A153M-B (1.5 oz/ft²)

Wire (Stainless Steel): ASTM A580/A580M - AISI Type 304 or Type 316

U.S. Patent No. 8,037,653, 9,140,001 & 9,758,958

Canadian Patent No. 2,690,819

OTHER PATENTS PENDING

Barrel Finish (Screw is Polymer Coated Steel):

Type 304 Stainless Steel Barrel

Thermal Concrete Tie Size (Equal to thickness of insulation):

5/8" 2" 3½" 5"
 1" 2½" 4"
 1½" 3" 4½"

2-Seal Byna-Lok™ Wire Tie Finish:

Hot-Dip Galvanized | Stainless Steel Type 304 Type 316

2-Seal Byna-Lok™ Wire Tie Length: (3/16"Ø)

3" 4" 5" Custom _____

Continuous Wire Finish:

Hot-Dip Galvanized | Stainless Steel Type 304 Type 316

Continuous Wire Diameter: 9 gauge 3/16"Ø

Thermal 2-Seal™ Chuck Adapter (required)

Note: Hohmann & Barnard recommends **Stainless Steel** for maximum protection against corrosion.

NOTE: Some configurations are non-stock, contact your local sales manager for price, availability and lead times.

IMPORTANT: Since each construction project is unique, the appropriate selection and use of any product contained herein must be determined by competent architects, engineers and other appropriate professionals who are familiar with the specific requirements of the project in question. This drawing and/or data sheet is the confidential and proprietary information of Hohmann & Barnard, Inc. and is not to be reproduced, copied or disclosed, in whole or in part, without the prior written consent of H&B.

HOHMANN & BARNARD, INC.
CORPORATE HEADQUARTERS
30 Rasons Ct.
Hauppauge, NY 11788
T: 800-645-0616 | www.h-b.com

Branch/Subsidiary Locations:
ALABAMA - ILLINOIS - MARYLAND
NEW YORK - PENNSYLVANIA - TEXAS
UTAH - CANADA

© 2013-2021