



TJI[®] 110, TJI[®] 210, TJI[®] 230, TJI[®] 360, TJI[®] 560, AND TJI[®] 560D JOISTS



Featuring Trus Joist[®] TJI[®] Joists for
Floor and Roof Applications

- Uniform and Predictable
- Lightweight for Fast Installation
- Resource Efficient
- Resists Bowing, Twisting, and Shrinking
- Significantly Reduces Callbacks
- Available in Long Lengths
- Limited Product Warranty



**New! Design 24" wide
holes with TJI[®] joists.
See page 11.**



The products in this guide are readily available through our nationwide network of distributors and dealers. For more information on other applications or other Trus Joist® products, contact your Weyerhaeuser representative.

This guide is for use with NBCC 2010, NBCC 2015, CSA O86-09, and CSA O86-14.

Code Evaluations:
CCMC 13132-R, CCRR 0222C

TABLE OF CONTENTS

Fire-Safe Construction	3
Tips for Preventing Floor Noise	3
Visual Literature Guide	4
TJ-Pro™ Rating and Floor Performance	5

SECTION 1: 9½"-16" TJI® Joists

Design Properties	6
Floor Span Tables	7-9
Allowable Holes	10-11
Cantilevers	12-13
Roof Span Table	14
Roof Load Table	15
Framing Connectors	16-17

SECTION 2: 18"-24" TJI® Joists

Design Properties	18
Floor Span Tables	18-19
Allowable Holes	20-21
Roof Span Table	22
Roof Load Table	22
Cantilevers	23-24
Framing Connectors	25-26

SECTION 3: Design Information for All Joists

TJI® Joist Floor Framing	27
Rim Board Selection and Installation	28
Floor Details	29-30
Roof Framing	31
Roof Details	32-34
Cut Length Calculation	35
Material Weights and Conversion Tables	35



Certified Sourcing

www.sfiprogram.org
SFI-00008

Why Choose Trus Joist® TJI® Joists?

- Engineered for strength and consistency
- Efficient installation saves time and labor
- Longer lengths allow more versatile floor plans
- Less jobsite waste
- Fewer red tags and callbacks



Now more than ever builders need solutions that really deliver. That's why Trus Joist® TJI® joists are designed to give you more—longer lengths, easier installation, higher span values, better strength-to-weight ratios, and faster cycle times.

TJI® joists are also available in deeper depths that are suitable for heavier-duty loads, such as those in multi-family structures and light commercial buildings.

This guide features TJI® joists in the following sizes:

Depths: 9½", 11⅞", 14", 16", 18", 20", 22", and 24"

Flange Widths: 1¾", 2¼", 2⅝", and 3½"

Flange height and thickness vary by series; see the appropriate sections of this guide for specific sizes and relevant technical information:

9½"-16" JOISTS

Section 1:

Design information for 9½"-16" TJI® joists

18"-24" JOISTS

Section 2:

Design information for 18"-24" TJI® joists

ALL JOIST DEPTHS

Section 3:

Framing details and design information for all joist depths in this guide

Some products may not be available in your region.

Contact your Weyerhaeuser representative at our [Specification Center](#) or visit "[Where to Buy](#)".

Safety data sheets for all Weyerhaeuser wood products can be found on our website at: weyerhaeuser.com/sustainability/environment/product-stewardship/safety-data-sheets.

PRODUCT STORAGE



Protect product from sun and water

CAUTION:
Wrap is slippery when wet or icy

Align stickers (2x3 or larger)
directly over support blocks

Use support blocks (6x6 or larger)
at 10' on-centre to keep bundles
out of mud and water

FIRE-SAFE CONSTRUCTION

For over 40 years, prefabricated wood I-joists and other Weyerhaeuser building products have established a record of safe and reliable performance in millions of structures. Many of these structures, such as one- or two-family residential dwellings, do not require specific fire-resistance ratings per building codes but may require unrated membrane protection. The information below is intended to help you specify and install Trus Joist® products with fire safety in mind.

One-Hour Assembly for Rated Construction

Double Layer

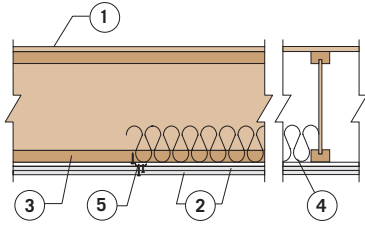

1. 48/24 tongue-and-groove, span-rated sheathing (Exposure 1), glued with a subfloor adhesive and nailed.
2. Two layers of 5/8" Type X gypsum board complying with ASTM C1396 or two layers of 1/2" Type C gypsum board.
3. TJI® joist
4. 3/2"-thick glass fiber insulation (optional)
5. Resilient channels (required if insulation is used, optional if insulation is omitted)

Intertek listings:

WNR FCA 60-01 (no channels)

WNR FCA 60-03 (with channels)

Suggested Minimum Membrane Protection for Unrated Construction

Single Layer

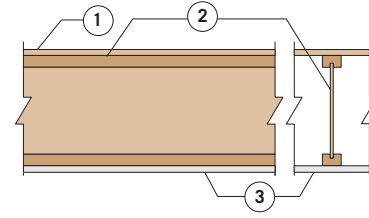

1. Appropriate span-rated sheathing (Exposure 1).
2. TJI® joist
3. Single-layer of 1/2" gypsum board

For more information on fire assemblies and fire-safe construction, please refer to the Weyerhaeuser Fire-Rated Assemblies and Sprinkler Systems Guide, TJ-1500, or visit weyerhaeuser.com/woodproducts.

TIPS FOR PREVENTING FLOOR NOISE

Trus Joist® TJI® joists are structurally uniform and dimensionally stable, and they resist shrinking and twisting. This helps prevent gaps from forming around the nails between the joist and the floor panels—gaps that can potentially cause squeaks or other floor noise. Using TJI® joists can help you build a quieter floor, but only if the entire floor system is installed properly. This is because other components of the floor system, such as hangers, connectors, and nails can be a source of floor noise.

Properly Seat Each Joist in Hanger

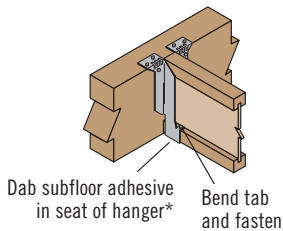

Seat the joist tight to the bottom of the hanger. When using hangers with tabs, bend the flange tabs over and nail to the TJI® joist bottom flange. Placing a dab of subfloor adhesive* in the seat of the hanger prior to installing the joist can reduce squeaks.

Use Adhesive and Special Nailing When Needed

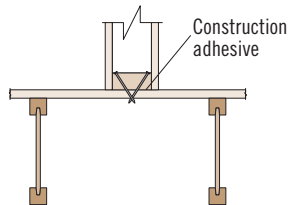

Nail interior partitions to the joists when possible. If the wall can be nailed only to the floor panel, run a bead of adhesive* under the wall and either cross nail, nail through and clinch tight, or screw tightly into the wall from below.

Prevent Shrinkage

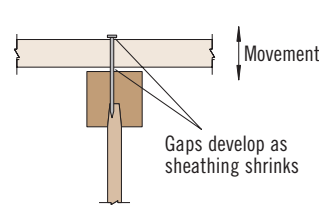

Keep building materials dry, and properly glue floor panels to the joists. Panels that become excessively wet during construction shrink as they dry. This shrinkage may leave gaps that allow the panel to move when stepped on.

Avoid "Shiners"

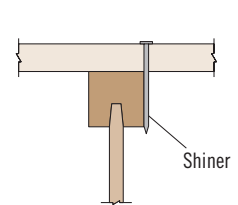

Exercise care when nailing. Nails that barely hit the joists (shiners) do not hold the panel tight to the joist and should be removed. If left in, the nails will rub against the side of the joist when the panel deflects.

* Weyerhaeuser recommends using a subfloor adhesive that has been qualified as a Class 1/8 in., Type P/O subfloor adhesive in accordance with ASTM D3498-19.

For more information and tips on how to prevent floor noise, refer to the Weyerhaeuser Prevention and Repair of Floor System Squeaks Technical Resource Sheet, 9009, or contact your Weyerhaeuser representative.

TimberStrand® LSL Rim Board
Rim Board Guide: [TJ-8500](#)

Floor/Ceiling Assemblies
Fire Assemblies and Sprinklers: [TJ-1500](#)
CVPC piping to TJI web: [TJ-1500](#)
Sound Ratings: [TJ-4035](#)

Allowable Holes
[Hole Charts \(9½" -16" depths\)](#)

Floor Framing
[TJI Floor Details](#)
[Cantilevers \(9½" -16" depths\)](#)

Roof Framing
[TJI Roof Details](#)

Balconies, Decks, Walkways
TJI® joists, TimberStrand® LSL, Microllam® LVL and untreated Parallam® PSL are intended for dry-use applications
Balconies, Decks, Walkways: [TB-128](#)
Moisture Effects: [TB-112](#)
Preservative Treatments: [TB-315](#)

TimberStrand® LSL Headers & Wall Framing
Canada Wall Guide: [TJ-9503](#)

Trus Joist® Engineered Wood Beams & Columns
Beams, Headers and Columns - Eastern Canada: [TJ-9500](#)
Beams, Headers and Columns - Western Canada: [TJ-9505](#)

Stair Stringers and Treads
Specifier's Guide: [9010](#)

Edge® / Edge Gold™
Edge® and Edge Gold™ Panels: [OSB-4501](#)

Installation Guides
Pocket Framer's Guide: [TJ-9001](#)

Building Code Evaluations
[CCMC 08675-R](#)
[CCMC 11161-R](#)
[CCMC 12627-R](#)
[CCMC 13132-R](#)
[Intertek CCRR 0222C](#)

*Some products may not be available in your region.
Contact your Weyerhaeuser representative at our [Specification Center](#) or visit "Where to Buy".*

What is Floor Performance and TJ-Pro Rating?

Floor performance is how a floor feels under foot traffic. TJ-Pro Rating is a diagnostic tool developed by Weyerhaeuser to help you assess floor performance based on the floor assembly components you specify. You can access TJ-Pro rating using our [ForteWEB®](#) and [Javelin®](#) software platforms or our span table [web app](#).

How does TJ-Pro Rating Work?

Point values up to 65 are assigned using complex algorithms based on field and laboratory research conducted on over 600 floor system assemblies. It also factors in the variables listed under **Key Factors Affecting Performance** shown to the right. Ranges can then be correlated to customer floor performance expectations.



What do the ratings mean?

The ratings represent the percentage of customers that would be satisfied with the floor performance. At 45 points, customer satisfaction is 84%. At 65 points, it's nearly 100%.

How can you use TJ-Pro Rating?

You know your market and TJ-Pro Ratings let you build what your market needs. For example, once you know that a TJ-Pro Rating of 45 points works for your customers, you can simply target 45 points for your other floors to deliver the performance your market expects.

It's also a great tool to optimize floors for the type of home you build:

Entry Level: Focus on economy and efficiency. Use TJ-Pro Ratings to make sure you're not overbuilding.

Move-Up/Mid-Level: Countless floor plans with upgrades options. Use TJ-Pro Rating to consistently and reliably build across the range of framing solutions.

High-End Luxury: Uncompromised quality and reputation is key. From our experience, homeowners in this group expect a rating of 45 points or greater. Use TJ-Pro Rating to differentiate yourself and deliver the quality your customers demand.

Key Factors Affecting Performance

- **Basic Stiffness** is a combination of joist depths and span.
- **Composite Action**—Careful nailing in conjunction with construction adhesives increases basic stiffness.
- **Continuity**—Continuous joists over several supports generally perform better than simple spans. Care must be taken if the joists continue into another occupancy.
- **Joist Spacing and Deck Stiffness**—Reduced spacing or increased deck thickness generally improves floor performance.
- **Ceilings** directly applied to the bottom edge of the floor members, or equivalent 1x or 2x strapping, is a performance enhancement.
- **Beams**—Floor systems supported by steel or wood beams tend to feel less stiff than those supported by solid bearing walls.
- **Bridging or Blocking** can be a contributor to improved floor performance.
- **Non-bearing Partition Walls** dampen vibration and improve floor performance when installed transverse to the floor joists.
- **Mass** reduces damping in a floor system causing a decrease in floor performance. This impact is more noticeable as span lengths increase.

TJ-Pro Rating is featured in these design software platforms.



Autodesk® Revit® linked to ForteWEB®

Let one of our experienced **Territory Managers** perform a TJ-Pro Rating assessment on your floors to give you insight on how well your floors will perform against your customers expectations. They can also help recommend products which will give you the optimal results you are looking for without overspending.

SECTION 1: 9½"-16" TJI® JOISTS

This section contains design information for 9½"-16" deep Trus Joist® TJI® joists.

These standard-size TJI® joists are readily available through your local Weyerhaeuser dealer or distributor. Offered with the flange sizes shown below, they come in lengths up to 60' (in 1' increments).

Design Properties

Depth	TJI®	Joist Weight (lbs/ft)	Joist Only EI x 10 ⁶ (lbs-in. ²)	Factored Resistances—Standard Term							
				Maximum Resistive Moment ⁽¹⁾ (ft-lbs)	Maximum Vertical Shear (lbs)	1¼" End Reaction (lbs)		3½" Intermediate Reaction (lbs)		5¼" Intermediate Reaction (lbs)	
						No Web Stiffeners	With Web Stiffeners ⁽²⁾	No Web Stiffeners	With Web Stiffeners ⁽²⁾	No Web Stiffeners	With Web Stiffeners ⁽²⁾
9½"	110	2.3	157	4,160	1,925	1,435	N.A.	3,055	N.A.	3,705	N.A.
	210	2.6	186	4,990	2,100	1,585	N.A.	3,385	N.A.	4,050	N.A.
	230	2.7	206	5,540	2,100	1,675	N.A.	3,800	N.A.	4,405	N.A.
	360	2.7	249	7,965	2,250	1,705	N.A.	3,885	N.A.	4,740	N.A.
	560	3.6	378	12,235	2,635	1,995	N.A.	4,735	N.A.	5,455	N.A.
11⅞"	110	2.5	267	5,255	2,460	1,435	1,885	3,055	3,575	3,705	4,225
	210	2.8	315	6,310	2,610	1,585	2,105	3,385	3,905	4,050	4,570
	230	3.0	347	7,010	2,610	1,675	2,190	3,800	4,320	4,405	4,925
	360	3.0	419	10,280	2,690	1,705	2,225	3,885	4,400	4,740	5,255
	560	4.0	636	15,795	3,235	1,995	2,680	4,735	5,425	5,455	6,140
14"	110	2.8	392	6,220	2,935	1,435	1,885	3,055	3,575	3,705	4,225
	210	3.1	462	7,470	3,070	1,585	2,105	3,385	3,905	4,050	4,570
	230	3.3	509	8,300	3,070	1,675	2,190	3,800	4,320	4,405	4,925
	360	3.3	612	12,200	3,085	1,705	2,225	3,885	4,400	4,740	5,255
	560	4.2	926	18,755	3,770	1,995	2,680	4,735	5,425	5,455	6,140
16"	210	3.3	629	8,550	3,455	1,585	2,105	3,385	3,905	4,050	4,570
	230	3.5	691	9,495	3,455	1,675	2,190	3,800	4,320	4,405	4,925
	360	3.5	830	13,980	3,455	1,705	2,225	3,885	4,400	4,740	5,255
	560	4.5	1,252	21,495	4,280	1,995	2,680	4,735	5,425	5,455	6,140

(1) Caution: Do not increase joist moment design properties by a repetitive-member-use factor.
 (2) See detail W on page 30 for web stiffener requirements and nailing information.

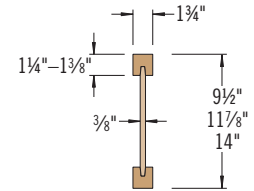

TJI® 110 joists

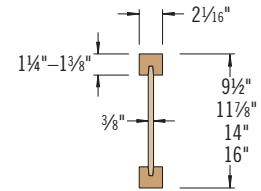

TJI® 210 joists

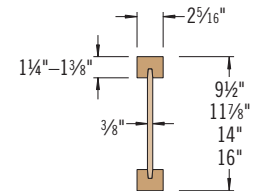

TJI® 230 joists

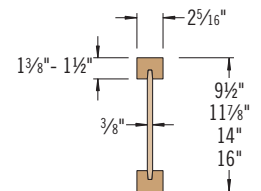

TJI® 360 joists

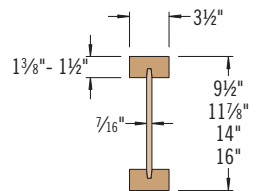

TJI® 560 joists

TJI® joists are intended for dry-use applications

Some TJI® joist series may not be available in your region. Contact your Weyerhaeuser representative for information.

General Notes

- Factored resistances are based on Limit States Design per CSA 086.
- Factored reaction includes all loads on the joist.
- Factored shear is computed at the inside face of supports and includes all loads on the span(s). Factored shear resistance may sometimes be increased at interior supports. For more information contact your Weyerhaeuser representative.
- The following formulas approximate the simple span uniform load deflection of Δ (inches):

For TJI® 110, 210, 230, and 360 Joists

$$\Delta = \frac{22.5 wL^4}{EI} + \frac{2.67 wL^2}{d \times 10^5}$$

For TJI® 560 Joists

$$\Delta = \frac{22.5 wL^4}{EI} + \frac{2.29 wL^2}{d \times 10^5}$$

w = uniform load in pounds per linear foot
 L = span in feet

d = out-to-out depth of the joist in inches
 EI = value from table above



DO NOT walk on joists until braced. INJURY MAY RESULT.



DO NOT stack building materials on unsheathed joists. Stack only over beams or walls.



DO NOT walk on joists that are lying flat.

WARNING

Joists are unstable until braced laterally

Bracing Includes:

- Blocking
- Hangers
- Rim Board
- Sheathing
- Rim Joist
- Strut Lines

WARNING NOTES:

Lack of proper bracing during construction can result in serious accidents. Observe the following guidelines:

- All blocking, hangers, rim boards, and rim joists at the end supports of the TJI® joists must be completely installed and properly nailed.
- Lateral strength, like a braced end wall or an existing deck, must be established at the ends of the bay. This can also be accomplished by a temporary or permanent deck (sheathing) fastened to the first 4 feet of joists at the end of the bay.
- Safety bracing of 1x4 (minimum) must be nailed to a braced end wall or sheathed area (as in note 2) and to each joist. Without this bracing, buckling sideways or rollover is highly probable under light construction loads—such as a worker or one layer of unnailed sheathing.
- Sheathing must be completely attached to each TJI® joist before additional loads can be placed on the system.
- Ends of cantilevers require safety bracing on both the top and bottom flanges.
- The flanges must remain straight within a tolerance of ½" from true alignment.

5/8" OSB Subfloor (Glue-nailed)—Vibration-Controlled, Standard Term

Depth	TJI®	Directly Applied Ceiling						No Directly Applied Ceiling					
		Simple or Continuous Span			Continuous Span Only			Simple or Continuous Span			Continuous Span Only		
		12" o.c.	16" o.c.	19.2" o.c.	12" o.c.	16" o.c.	19.2" o.c.	12" o.c.	16" o.c.	19.2" o.c.	12" o.c.	16" o.c.	19.2" o.c.
40 PSF Live Load / 15 PSF Dead Load													
9½"	110	15'-9"	14'-10"	14'-4"	16'-5"	15'-6"	15'-0"	15'-3"	14'-5"	13'-11"	15'-11"	15'-0"	14'-6"
	210	16'-1"	15'-3"	14'-8"	16'-10"	15'-11"	15'-4"	15'-8"	14'-9"	14'-3"	16'-4"	15'-5"	14'-11"
	230	16'-4"	15'-5"	14'-11"	17'-1"	16'-2"	15'-7"	15'-11"	15'-0"	14'-6"	16'-8"	15'-8"	15'-2"
	360	16'-10"	15'-11"	15'-4"	17'-7"	16'-7"	16'-0"	16'-5"	15'-6"	14'-11"	17'-2"	16'-2"	15'-8"
	560	18'-2"	17'-0"	16'-5"	19'-2"	17'-10"	17'-2"	17'-9"	16'-8"	16'-1"	18'-8"	17'-5"	16'-10"
11⅞"	110	17'-7"	16'-8"	16'-1"	18'-7"	17'-5"	16'-10"	17'-1"	16'-1"	15'-7"	17'-10"	16'-10"	16'-3"
	210	18'-1"	17'-1"	16'-6"	19'-2"	17'-10"	17'-3"	17'-7"	16'-6"	16'-0"	18'-5"	17'-3"	16'-8"
	230	18'-5"	17'-4"	16'-9"	19'-6"	18'-2"	17'-6"	17'-10"	16'-10"	16'-3"	18'-10"	17'-7"	16'-11"
	360	19'-2"	17'-10"	17'-2"	20'-3"	18'-10"	18'-0"	18'-6"	17'-4"	16'-9"	19'-7"	18'-2"	17'-6"
	560	21'-0"	19'-5"	18'-6"	22'-2"	20'-6"	19'-7"	20'-5"	18'-10"	18'-0"	21'-7"	19'-11"	19'-1"
14"	110	19'-6"	18'-2"	17'-6"	20'-8"	19'-3"	18'-5"	18'-9"	17'-6"	16'-11"	19'-9"	18'-4"	17'-8"
	210	20'-2"	18'-9"	17'-11"	21'-3"	19'-10"	19'-0"	19'-5"	18'-0"	17'-4"	20'-6"	19'-0"	18'-2"
	230	20'-6"	19'-1"	18'-3"	21'-8"	20'-2"	19'-4"	19'-9"	18'-4"	17'-8"	20'-11"	19'-5"	18'-7"
	360	21'-3"	19'-9"	18'-10"	22'-6"	20'-11"	20'-0"	20'-7"	19'-1"	18'-3"	21'-9"	20'-2"	19'-3"
	560	23'-4"	21'-7"	20'-7"	24'-8"	22'-10"	21'-9"	22'-8"	20'-11"	20'-0"	24'-0"	22'-2"	21'-2"
16"	210	21'-11"	20'-5"	19'-6"	23'-2"	21'-7"	20'-8"	21'-1"	19'-7"	18'-9"	22'-4"	20'-8"	19'-9"
	230	22'-4"	20'-9"	19'-10"	23'-8"	22'-0"	21'-0"	21'-6"	19'-11"	19'-1"	22'-9"	21'-1"	20'-2"
	360	23'-2"	21'-6"	20'-7"	24'-6"	22'-9"	21'-9"	22'-5"	20'-9"	19'-10"	23'-8"	21'-11"	20'-11"
	560	25'-5"	23'-6"	22'-5"	26'-10"	24'-10"	23'-8"	24'-8"	22'-9"	21'-9"	26'-2"	24'-1"	23'-0"
40 PSF Live Load / 30 PSF Dead Load													
9½"	110	15'-9"	14'-10"	14'-4"	16'-5"	15'-6"	14'-6"	15'-3"	14'-5"	13'-11"	15'-11"	15'-0"	14'-6"
	210	16'-1"	15'-3"	14'-8"	16'-10"	15'-11"	15'-4"	15'-8"	14'-9"	14'-3"	16'-4"	15'-5"	14'-11"
	230	16'-4"	15'-5"	14'-11"	17'-1"	16'-2"	15'-7"	15'-11"	15'-0"	14'-6"	16'-8"	15'-8"	15'-2"
	360	16'-10"	15'-11"	15'-4"	17'-7"	16'-7"	16'-0"	16'-5"	15'-6"	14'-11"	17'-2"	16'-2"	15'-8"
	560	18'-2"	17'-0"	16'-5"	19'-2"	17'-10"	17'-2"	17'-9"	16'-8"	16'-1"	18'-8"	17'-5"	16'-10"
11⅞"	110	17'-7"	16'-8"	16'-1 ⁽¹⁾	18'-7"	17'-5"	16'-3 ⁽¹⁾	17'-1"	16'-1"	15'-7 ⁽¹⁾	17'-10"	16'-10"	16'-3⁽¹⁾
	210	18'-1"	17'-1"	16'-6"	19'-2"	17'-10"	17'-3 ⁽¹⁾	17'-7"	16'-6"	16'-0"	18'-5"	17'-3"	16'-8"
	230	18'-5"	17'-4"	16'-9"	19'-6"	18'-2"	17'-6"	17'-10"	16'-10"	16'-3"	18'-10"	17'-7"	16'-11"
	360	19'-2"	17'-10"	17'-2"	20'-3"	18'-10"	18'-0"	18'-6"	17'-4"	16'-9"	19'-7"	18'-2"	17'-6"
	560	21'-0"	19'-5"	18'-6"	22'-2"	20'-6"	19'-7"	20'-5"	18'-10"	18'-0"	21'-7"	19'-11"	19'-1"
14"	110	19'-6"	18'-2"	17'-6 ⁽¹⁾	20'-8"	19'-3 ⁽¹⁾	17'-9 ⁽¹⁾	18'-9"	17'-6"	16'-11 ⁽¹⁾	19'-9"	18'-4"	17'-8 ⁽¹⁾
	210	20'-2"	18'-9"	17'-11 ⁽¹⁾	21'-3"	19'-10"	19'-0 ⁽¹⁾	19'-5"	18'-0"	17'-4 ⁽¹⁾	20'-6"	19'-0"	18'-2 ⁽¹⁾
	230	20'-6"	19'-1"	18'-3"	21'-8"	20'-2"	19'-4"	19'-9"	18'-4"	17'-8"	20'-11"	19'-5"	18'-7"
	360	21'-3"	19'-9"	18'-10"	22'-6"	20'-11"	20'-0 ⁽¹⁾	20'-7"	19'-1"	18'-3"	21'-9"	20'-2"	19'-3"
	560	23'-4"	21'-7"	20'-7"	24'-8"	22'-10"	21'-9"	22'-8"	20'-11"	20'-0"	24'-0"	22'-2"	21'-2"
16"	210	21'-11"	20'-5"	19'-6 ⁽¹⁾	23'-2"	21'-7 ⁽¹⁾	19'-11 ⁽¹⁾	21'-1"	19'-7"	18'-9 ⁽¹⁾	22'-4"	20'-8"	19'-9 ⁽¹⁾
	230	22'-4"	20'-9"	19'-10 ⁽¹⁾	23'-8"	22'-0"	21'-0 ⁽¹⁾	21'-6"	19'-11"	19'-1"	22'-9"	21'-1"	20'-2 ⁽¹⁾
	360	23'-2"	21'-6"	20'-7 ⁽¹⁾	24'-6"	22'-9"	21'-9 ⁽¹⁾	22'-5"	20'-9"	19'-10 ⁽¹⁾	23'-8"	21'-11"	20'-11 ⁽¹⁾
	560	25'-5"	23'-6"	22'-5"	26'-10"	24'-10"	23'-8"	24'-8"	22'-9"	21'-9"	26'-2"	24'-1"	23'-0"

(1) Web stiffeners are required at intermediate supports of continuous-span joists when the intermediate bearing length is less than 5¼" and the span on either side of the intermediate bearing is greater than the following spans:

40 PSF Live Load / 15 PSF Dead Load				40 PSF Live Load / 30 PSF Dead Load		
TJI®	12" o.c.	16" o.c.	19.2" o.c.	12" o.c.	16" o.c.	19.2" o.c.
110	Not Required			Not Required	18'-8"	15'-6"
210					20'-8"	17'-3"
230						19'-4"
360						19'-9"
560						

• **Bold italic** spans indicate floors that would meet National Building Code of Canada (NBCC) vibration criteria but would be considered by 35% of the population to have marginal or unacceptable performance.

How to Use These Tables

- Determine the subflooring thickness and applicable live and dead loads.
- Determine whether the ceiling will be directly applied and what the span condition is (simple or continuous).
- Select on-centre spacing.
- Scan down the column until you meet or exceed the span of your application.
- Select TJI® joist and depth.

To more accurately predict floor performance, use our TJ-Pro™ Ratings

See page 8 for General Notes.

3/4" OSB Subfloor (Glue-nailed)—Vibration-Controlled, Standard Term

Depth	TJI®	Directly Applied Ceiling								No Directly Applied Ceiling							
		Simple or Continuous Span				Continuous Span Only				Simple or Continuous Span				Continuous Span Only			
		12" o.c.	16" o.c.	19.2" o.c.	24" o.c.	12" o.c.	16" o.c.	19.2" o.c.	24" o.c.	12" o.c.	16" o.c.	19.2" o.c.	24" o.c.	12" o.c.	16" o.c.	19.2" o.c.	24" o.c.
40 PSF Live Load / 15 PSF Dead Load																	
9 1/2"	110	16'-6"	15'-7"	14'-10"	13'-8"	17'-3"	16'-4"	15'-9"	14'-5"	16'-1"	15'-2"	14'-7"	13'-8"	16'-9"	15'-10"	15'-3"	14'-5"
	210	16'-11"	16'-0"	15'-5"	14'-5"	17'-8"	16'-9"	16'-1"	15'-6"	16'-6"	15'-7"	15'-0"	14'-5"	17'-3"	16'-3"	15'-8"	15'-0"
	230	17'-2"	16'-3"	15'-8"	14'-11"	18'-0"	17'-0"	16'-4"	15'-8"	16'-9"	15'-10"	15'-3"	14'-7"	17'-6"	16'-6"	15'-11"	15'-3"
	360	17'-8"	16'-8"	16'-1"	15'-5"	18'-8"	17'-5"	16'-10"	16'-1"	17'-4"	16'-4"	15'-8"	15'-1"	18'-2"	17'-0"	16'-5"	15'-9"
	560	19'-3"	17'-10"	17'-2"	16'-5"	20'-5"	18'-11"	18'-0"	17'-2"	18'-10"	17'-6"	16'-10"	16'-2"	19'-11"	18'-5"	17'-8"	16'-11"
11 1/8"	110	18'-8"	17'-6"	16'-10"	16'-2" ⁽¹⁾	19'-9"	18'-5"	17'-8"	16'-2" ⁽¹⁾	18'-0"	16'-11"	16'-4"	15'-8"⁽¹⁾	19'-0"	17'-8"	17'-1"	16'-2"⁽¹⁾
	210	19'-3"	17'-11"	17'-3"	16'-7"	20'-4"	18'-11"	18'-1"	17'-4" ⁽¹⁾	18'-8"	17'-5"	16'-9"	16'-1"	19'-8"	18'-3"	17'-6"	16'-10"
	230	19'-7"	18'-3"	17'-6"	16'-9"	20'-9"	19'-3"	18'-5"	17'-7"	19'-0"	17'-8"	17'-0"	16'-4"	20'-1"	18'-7"	17'-9"	17'-1"
	360	20'-4"	18'-11"	18'-1"	17'-3"	21'-6"	20'-0"	19'-1"	18'-1"	19'-9"	18'-4"	17'-7"	16'-10"	20'-11"	19'-4"	18'-5"	17'-7"
	560	22'-3"	20'-7"	19'-7"	18'-7"	23'-7"	21'-10"	20'-9"	19'-8"	21'-9"	20'-1"	19'-2"	18'-1"	23'-0"	21'-3"	20'-3"	19'-2"
14"	110	20'-9"	19'-4"	18'-6"	17'-7" ⁽¹⁾	21'-11"	20'-5"	19'-6" ⁽¹⁾	17'-8" ⁽¹⁾	20'-0"	18'-7"	17'-9"	17'-0" ⁽¹⁾	21'-1"	19'-7"	18'-8"	17'-8" ⁽¹⁾
	210	21'-5"	19'-11"	19'-0"	18'-0" ⁽¹⁾	22'-8"	21'-1"	20'-1"	19'-1" ⁽¹⁾	20'-8"	19'-2"	18'-3"	17'-6" ⁽¹⁾	21'-10"	20'-3"	19'-4"	18'-4" ⁽¹⁾
	230	21'-10"	20'-3"	19'-4"	18'-4"	23'-1"	21'-5"	20'-6"	19'-5" ⁽¹⁾	21'-1"	19'-7"	18'-8"	17'-9"	22'-4"	20'-8"	19'-8"	18'-8"
	360	22'-7"	21'-0"	20'-0"	18'-11"	23'-11"	22'-2"	21'-2"	20'-1" ⁽¹⁾	22'-0"	20'-4"	19'-4"	18'-4"	23'-2"	21'-6"	20'-6"	19'-5"
	560	24'-9"	22'-11"	21'-9"	20'-7"	26'-2"	24'-3"	23'-1"	21'-10"	24'-2"	22'-4"	21'-3"	20'-1"	25'-7"	23'-7"	22'-5"	21'-2"
16"	210	23'-4"	21'-8"	20'-9"	19'-8" ⁽¹⁾	24'-8"	22'-11"	21'-11" ⁽¹⁾	19'-8" ⁽¹⁾	22'-6"	20'-10"	19'-11"	18'-10" ⁽¹⁾	23'-9"	22'-1"	21'-0"	19'-8" ⁽¹⁾
	230	23'-9"	22'-1"	21'-1"	20'-0" ⁽¹⁾	25'-1"	23'-4"	22'-3"	21'-2" ⁽¹⁾	23'-0"	21'-3"	20'-3"	19'-3" ⁽¹⁾	24'-3"	22'-6"	21'-5"	20'-4" ⁽¹⁾
	360	24'-7"	22'-10"	21'-9"	20'-8" ⁽¹⁾	26'-0"	24'-2"	23'-1"	21'-10" ⁽¹⁾	23'-11"	22'-1"	21'-1"	19'-11" ⁽¹⁾	25'-3"	23'-4"	22'-3"	21'-1" ⁽¹⁾
	560	26'-11"	24'-11"	23'-9"	22'-5"	28'-6"	26'-4"	25'-1"	23'-9"	26'-4"	24'-3"	23'-1"	21'-9"	27'-10"	25'-8"	24'-5"	23'-1"
	40 PSF Live Load / 30 PSF Dead Load																
9 1/2"	110	16'-6"	15'-7"	14'-6"	12'-5"	17'-3"	15'-10"	14'-6"	12'-5"	16'-1"	15'-2"	14'-6"	12'-5"	16'-9"	15'-10"	14'-6"	12'-5"
	210	16'-11"	16'-0"	15'-5"	13'-9"	17'-8"	16'-9"	15'-10"	13'-9"	16'-6"	15'-7"	15'-0"	13'-9"	17'-3"	16'-3"	15'-8"	13'-9"
	230	17'-2"	16'-3"	15'-8"	14'-11"	18'-0"	17'-0"	16'-4"	14'-11"	16'-9"	15'-10"	15'-3"	14'-7"	17'-6"	16'-6"	15'-11"	14'-11"
	360	17'-8"	16'-8"	16'-1"	15'-5"	18'-8"	17'-5"	16'-10"	15'-10"	17'-4"	16'-4"	15'-8"	15'-1"	18'-2"	17'-0"	16'-5"	15'-9"
	560	19'-3"	17'-10"	17'-2"	16'-5"	20'-5"	18'-11"	18'-0"	17'-2"	18'-10"	17'-6"	16'-10"	16'-2"	19'-11"	18'-5"	17'-8"	16'-11"
11 1/8"	110	18'-8"	17'-6"	16'-3" ⁽¹⁾	14'-6" ⁽¹⁾	19'-9"	17'-10"	16'-3" ⁽¹⁾	14'-6" ⁽¹⁾	18'-0"	16'-11"	16'-3" ⁽¹⁾	14'-6" ⁽¹⁾	19'-0"	17'-8"	16'-3" ⁽¹⁾	14'-6" ⁽¹⁾
	210	19'-3"	17'-11"	17'-3" ⁽¹⁾	15'-10" ⁽¹⁾	20'-4"	18'-11"	17'-10" ⁽¹⁾	15'-10" ⁽¹⁾	18'-8"	17'-5"	16'-9"	15'-10" ⁽¹⁾	19'-8"	18'-3"	17'-6" ⁽¹⁾	15'-10" ⁽¹⁾
	230	19'-7"	18'-3"	17'-6"	16'-9" ⁽¹⁾	20'-9"	19'-3"	18'-5"	16'-10" ⁽¹⁾	19'-0"	17'-8"	17'-0"	16'-4" ⁽¹⁾	20'-1"	18'-7"	17'-9"	16'-10" ⁽¹⁾
	360	20'-4"	18'-11"	18'-0"	17'-3" ⁽¹⁾	21'-6"	20'-0"	19'-1"	17'-11" ⁽¹⁾	19'-9"	18'-4"	17'-7"	16'-10" ⁽¹⁾	20'-11"	19'-4"	18'-5"	17'-7" ⁽¹⁾
	560	22'-3"	20'-7"	19'-7"	18'-7"	23'-7"	21'-10"	20'-9"	19'-8" ⁽¹⁾	21'-9"	20'-1"	19'-2"	18'-1"	23'-0"	21'-3"	20'-3"	19'-2"
14"	110	20'-9"	19'-4" ⁽¹⁾	17'-9" ⁽¹⁾	14'-6" ⁽¹⁾	21'-11"	19'-5" ⁽¹⁾	17'-9" ⁽¹⁾	14'-6" ⁽¹⁾	20'-0"	18'-7"	17'-9" ⁽¹⁾	14'-6" ⁽¹⁾	21'-1"	19'-5" ⁽¹⁾	17'-9" ⁽¹⁾	14'-6" ⁽¹⁾
	210	21'-5"	19'-11"	19'-0" ⁽¹⁾	15'-10" ⁽¹⁾	22'-8"	21'-1" ⁽¹⁾	19'-5" ⁽¹⁾	15'-10" ⁽¹⁾	20'-8"	19'-2"	18'-3" ⁽¹⁾	15'-10" ⁽¹⁾	21'-10"	20'-3"	19'-4" ⁽¹⁾	15'-10" ⁽¹⁾
	230	21'-10"	20'-3"	19'-4" ⁽¹⁾	17'-0" ⁽¹⁾	23'-1"	21'-5"	20'-6" ⁽¹⁾	17'-7" ⁽¹⁾	21'-1"	19'-7"	18'-8"	17'-0" ⁽¹⁾	22'-4"	20'-8"	19'-8" ⁽¹⁾	17'-7" ⁽¹⁾
	360	22'-7"	21'-0"	20'-0" ⁽¹⁾	17'-4" ⁽¹⁾	23'-11"	22'-2"	21'-2" ⁽¹⁾	17'-11" ⁽¹⁾	22'-0"	20'-4"	19'-4"	17'-4" ⁽¹⁾	23'-2"	21'-6"	20'-6" ⁽¹⁾	17'-11" ⁽¹⁾
	560	24'-9"	22'-11"	21'-9"	20'-4" ⁽¹⁾	26'-2"	24'-3"	23'-1"	21'-10" ⁽¹⁾	24'-2"	22'-4"	21'-3"	20'-1" ⁽¹⁾	25'-7"	23'-7"	22'-5"	21'-2" ⁽¹⁾
16"	210	23'-4"	21'-8" ⁽¹⁾	19'-11" ⁽¹⁾	15'-10" ⁽¹⁾	24'-8"	22'-10" ⁽¹⁾	19'-11" ⁽¹⁾	15'-10" ⁽¹⁾	22'-6"	20'-10" ⁽¹⁾	19'-11" ⁽¹⁾	15'-10" ⁽¹⁾	23'-9"	22'-1" ⁽¹⁾	19'-11" ⁽¹⁾	15'-10" ⁽¹⁾
	230	23'-9"	22'-1"	21'-1" ⁽¹⁾	17'-0" ⁽¹⁾	25'-1"	23'-4" ⁽¹⁾	21'-11" ⁽¹⁾	17'-7" ⁽¹⁾	23'-0"	21'-3"	20'-3" ⁽¹⁾	17'-0" ⁽¹⁾	24'-3"	22'-6"	21'-5" ⁽¹⁾	17'-7" ⁽¹⁾
	360	24'-7"	22'-10"	21'-9" ⁽¹⁾	17'-4" ⁽¹⁾	26'-0"	24'-2" ⁽¹⁾	22'-5" ⁽¹⁾	17'-11" ⁽¹⁾	23'-11"	22'-1"	21'-1" ⁽¹⁾	17'-4" ⁽¹⁾	25'-3"	23'-4"	22'-3" ⁽¹⁾	17'-11" ⁽¹⁾
	560	26'-11"	24'-11"	23'-9"	20'-4" ⁽¹⁾	28'-6"	26'-4"	25'-1" ⁽¹⁾	22'-1" ⁽¹⁾	26'-4"	24'-3"	23'-1"	20'-4" ⁽¹⁾	27'-10"	25'-8"	24'-5" ⁽¹⁾	22'-1" ⁽¹⁾

(1) Web stiffeners are required at intermediate supports of continuous-span joists when the intermediate bearing length is less than 5/4" and the span on either side of the intermediate bearing is greater than the following spans:

TJI®	40 PSF Live Load / 15 PSF Dead Load				40 PSF Live Load / 30 PSF Dead Load			
	12" o.c.	16" o.c.	19.2" o.c.	24" o.c.	12" o.c.	16" o.c.	19.2" o.c.	24" o.c.
110	Not Required		19'-3"	15'-4"	Not Required	18'-8"	15'-6"	12'-5"
210			21'-4"	17'-1"		20'-8"	17'-3"	13'-9"
230				19'-2"		23'-3"	19'-4"	15'-5"
360				19'-7"		23'-9"	19'-9"	15'-10"
560							24'-2"	19'-3"

To more accurately predict floor performance, use our TJI-Pro™ Ratings

▪ **Bold italic** spans indicate floors that would meet National Building Code of Canada (NBCC) vibration criteria but would be considered by 35% of the population to have marginal or unacceptable performance.

General Notes

- Tables are based on:
 - Clear distance between supports.
 - Minimum bearing length of 1 1/4" end (no web stiffeners) and 3 1/2" intermediate.
 - Limit States Design per CSA 086.
 - Uniform loads.
 - Single layer of appropriate span-rated OSB.
 - NBCC vibration criteria as ratified by Canadian Construction Materials Centre (CCMC).
- Long term deflection under dead load, which includes the effect of creep, has not been considered.
- For continuous spans, ratio of short span to long span should be 0.4 or greater to prevent uplift.
- Spans generated from Weyerhaeuser software may exceed the spans shown in these tables because software reflects actual design conditions.
- For multi-family applications and other loading conditions not shown, refer to Weyerhaeuser software.

See page 7 for how to use these tables.

7/8" OSB Subfloor (Glue-nailed)—Vibration-Controlled, Standard Term

Depth	TJI®	Directly Applied Ceiling								No Directly Applied Ceiling							
		Simple or Continuous Span				Continuous Span Only				Simple or Continuous Span				Continuous Span Only			
		12" o.c.	16" o.c.	19.2" o.c.	24" o.c.	12" o.c.	16" o.c.	19.2" o.c.	24" o.c.	12" o.c.	16" o.c.	19.2" o.c.	24" o.c.	12" o.c.	16" o.c.	19.2" o.c.	24" o.c.
40 PSF Live Load / 15 PSF Dead Load																	
9½"	110	17'-3"	15'-10"	14'-10"	13'-8"	18'-0"	17'-1"	16'-1"	14'-5"	16'-9"	15'-10"	14'-10"	13'-8"	17'-6"	16'-6"	15'-11"	14'-5"
	210	17'-8"	16'-8"	15'-8"	14'-5"	18'-7"	17'-6"	16'-10"	15'-9"	17'-3"	16'-3"	15'-8"	14'-5"	18'-0"	17'-0"	16'-4"	15'-8"
	230	17'-11"	16'-11"	16'-2"	14'-11"	19'-0"	17'-9"	17'-1"	16'-4"	17'-6"	16'-7"	15'-11"	14'-11"	18'-5"	17'-3"	16'-8"	15'-11"
	360	18'-7"	17'-5"	16'-9"	15'-11"	19'-8"	18'-4"	17'-6"	16'-9"	18'-2"	17'-1"	16'-5"	15'-8"	19'-2"	17'-10"	17'-2"	16'-4"
	560	20'-4"	18'-10"	17'-11"	17'-1"	21'-6"	19'-11"	19'-0"	17'-11"	19'-11"	18'-5"	17'-7"	16'-10"	21'-0"	19'-6"	18'-6"	17'-7"
11½"	110	19'-8"	18'-4"	17'-7"	16'-2 ⁽¹⁾	20'-10"	19'-5"	18'-1"	16'-2 ⁽¹⁾	19'-0"	17'-9"	17'-1"	16'-2 ⁽¹⁾	20'-1"	18'-8"	17'-10"	16'-2 ⁽¹⁾
	210	20'-4"	18'-11"	18'-1"	17'-3 ⁽¹⁾	21'-6"	20'-0"	19'-1"	17'-9 ⁽¹⁾	19'-8"	18'-3"	17'-6"	16'-9"	20'-9"	19'-4"	18'-5"	17'-6 ⁽¹⁾
	230	20'-8"	19'-3"	18'-4"	17'-6"	21'-10"	20'-4"	19'-5"	18'-4"	20'-1"	18'-8"	17'-9"	17'-0"	21'-2"	19'-8"	18'-9"	17'-9"
	360	21'-5"	19'-11"	19'-0"	17'-11"	22'-8"	21'-1"	20'-1"	19'-0"	20'-11"	19'-4"	18'-5"	17'-6"	22'-1"	20'-6"	19'-6"	18'-4"
	560	23'-5"	21'-9"	20'-8"	19'-6"	24'-9"	23'-0"	21'-11"	20'-7"	22'-11"	21'-3"	20'-2"	19'-0"	24'-3"	22'-5"	21'-4"	20'-1"
14"	110	21'-11"	20'-5"	19'-6 ⁽¹⁾	17'-8 ⁽¹⁾	23'-1"	21'-7"	19'-9 ⁽¹⁾	17'-8 ⁽¹⁾	21'-1"	19'-7"	18'-8"	17'-8 ⁽¹⁾	22'-3"	20'-8"	19'-9 ⁽¹⁾	17'-8 ⁽¹⁾
	210	22'-7"	21'-0"	20'-1"	18'-11 ⁽¹⁾	23'-10"	22'-3"	21'-3"	19'-4 ⁽¹⁾	21'-10"	20'-3"	19'-4"	18'-3 ⁽¹⁾	23'-1"	21'-5"	20'-5"	19'-3 ⁽¹⁾
	230	23'-0"	21'-5"	20'-5"	19'-3 ⁽¹⁾	24'-3"	22'-8"	21'-7"	20'-5 ⁽¹⁾	22'-3"	20'-8"	19'-8"	18'-7"	23'-6"	21'-10"	20'-10"	19'-7 ⁽¹⁾
	360	23'-10"	22'-2"	21'-1"	19'-11 ⁽¹⁾	25'-2"	23'-5"	22'-4"	21'-1 ⁽¹⁾	23'-2"	21'-6"	20'-5"	19'-3"	24'-6"	22'-8"	21'-7"	20'-4 ⁽¹⁾
	560	26'-0"	24'-2"	22'-11"	21'-7"	27'-6"	25'-6"	24'-3"	22'-10"	25'-6"	23'-7"	22'-5"	21'-1"	26'-11"	24'-11"	23'-8"	22'-3"
16"	210	24'-7"	22'-11"	21'-10 ⁽¹⁾	19'-8 ⁽¹⁾	25'-11"	24'-2"	23'-1 ⁽¹⁾	19'-8 ⁽¹⁾	23'-9"	22'-1"	21'-0"	19'-8 ⁽¹⁾	25'-1"	23'-3"	22'-2 ⁽¹⁾	19'-8 ⁽¹⁾
	230	25'-0"	23'-4"	22'-3"	21'-0 ⁽¹⁾	26'-5"	24'-8"	23'-6"	21'-10 ⁽¹⁾	24'-3"	22'-6"	21'-5"	20'-2 ⁽¹⁾	25'-7"	23'-9"	22'-7"	21'-4 ⁽¹⁾
	360	25'-11"	24'-1"	23'-0"	21'-6 ⁽¹⁾	27'-4"	25'-6"	24'-4"	22'-2 ⁽¹⁾	25'-2"	23'-4"	22'-3"	20'-11 ⁽¹⁾	26'-7"	24'-8"	23'-6"	22'-1 ⁽¹⁾
	560	28'-3"	26'-3"	25'-0"	23'-6"	29'-11"	27'-9"	26'-5"	24'-11 ⁽¹⁾	27'-8"	25'-7"	24'-4"	22'-11"	29'-3"	27'-1"	25'-9"	24'-2 ⁽¹⁾
	40 PSF Live Load / 30 PSF Dead Load																
9½"	110	17'-3"	15'-10"	14'-6"	12'-5"	18'-0"	15'-10"	14'-6"	12'-5"	16'-9"	15'-10"	14'-6"	12'-5"	17'-6"	15'-10"	14'-6"	12'-5"
	210	17'-8"	16'-8"	15'-8"	13'-9"	18'-7"	17'-5"	15'-10"	13'-9"	17'-3"	16'-3"	15'-8"	13'-9"	18'-0"	17'-0"	15'-10"	13'-9"
	230	17'-11"	16'-11"	16'-2"	14'-11"	19'-0"	17'-9"	16'-9"	14'-11"	17'-6"	16'-7"	15'-11"	14'-11"	18'-5"	17'-3"	16'-8"	14'-11"
	360	18'-7"	17'-5"	16'-9"	15'-10"	19'-8"	18'-4"	17'-6"	15'-10"	18'-2"	17'-1"	16'-5"	15'-8"	19'-2"	17'-10"	17'-2"	15'-10"
	560	20'-4"	18'-10"	17'-11"	17'-1"	21'-6"	19'-11"	19'-0"	17'-11"	19'-11"	18'-5"	17'-7"	16'-10"	21'-0"	19'-6"	18'-6"	17'-7"
11½"	110	19'-8"	17'-10"	16'-3 ⁽¹⁾	14'-6 ⁽¹⁾	20'-7"	17'-10"	16'-3 ⁽¹⁾	14'-6 ⁽¹⁾	19'-0"	17'-9"	16'-3 ⁽¹⁾	14'-6 ⁽¹⁾	20'-1"	17'-10"	16'-3 ⁽¹⁾	14'-6 ⁽¹⁾
	210	20'-4"	18'-11"	17'-10 ⁽¹⁾	15'-10 ⁽¹⁾	21'-6"	19'-7"	17'-10 ⁽¹⁾	15'-10 ⁽¹⁾	19'-8"	18'-3"	17'-6 ⁽¹⁾	15'-10 ⁽¹⁾	20'-9"	19'-4"	17'-10 ⁽¹⁾	15'-10 ⁽¹⁾
	230	20'-8"	19'-3"	18'-4"	16'-10 ⁽¹⁾	21'-10"	20'-4"	18'-10"	16'-10 ⁽¹⁾	20'-1"	18'-8"	17'-9"	16'-10 ⁽¹⁾	21'-2"	19'-8"	18'-9"	16'-10 ⁽¹⁾
	360	21'-5"	19'-11"	19'-0"	17'-4 ⁽¹⁾	22'-8"	21'-1"	20'-1 ⁽¹⁾	17'-11 ⁽¹⁾	20'-11"	19'-4"	18'-5"	17'-4 ⁽¹⁾	22'-1"	20'-6"	19'-6"	17'-11 ⁽¹⁾
	560	23'-5"	21'-9"	20'-8"	19'-6 ⁽¹⁾	24'-9"	23'-0"	21'-11"	20'-7 ⁽¹⁾	22'-11"	21'-3"	20'-2"	19'-0"	24'-3"	22'-5"	21'-4"	20'-1 ⁽¹⁾
14"	110	21'-11"	19'-5 ⁽¹⁾	17'-9 ⁽¹⁾	14'-6 ⁽¹⁾	22'-5"	19'-5 ⁽¹⁾	17'-9 ⁽¹⁾	14'-6 ⁽¹⁾	21'-1"	19'-5 ⁽¹⁾	17'-9 ⁽¹⁾	14'-6 ⁽¹⁾	22'-3"	19'-5 ⁽¹⁾	17'-9 ⁽¹⁾	14'-6 ⁽¹⁾
	210	22'-7"	21'-0 ⁽¹⁾	19'-5 ⁽¹⁾	15'-10 ⁽¹⁾	23'-10"	21'-4 ⁽¹⁾	19'-5 ⁽¹⁾	15'-10 ⁽¹⁾	21'-10"	20'-3"	19'-4 ⁽¹⁾	15'-10 ⁽¹⁾	23'-1"	21'-4 ⁽¹⁾	19'-5 ⁽¹⁾	15'-10 ⁽¹⁾
	230	23'-0"	21'-5"	20'-5 ⁽¹⁾	17'-0 ⁽¹⁾	24'-3"	22'-5"	20'-6 ⁽¹⁾	17'-7 ⁽¹⁾	22'-3"	20'-8"	19'-8 ⁽¹⁾	17'-0 ⁽¹⁾	23'-6"	21'-10"	20'-6 ⁽¹⁾	17'-7 ⁽¹⁾
	360	23'-10"	22'-2"	21'-1 ⁽¹⁾	17'-4 ⁽¹⁾	25'-2"	23'-5"	22'-4 ⁽¹⁾	17'-11 ⁽¹⁾	23'-2"	21'-6"	20'-5 ⁽¹⁾	17'-4 ⁽¹⁾	24'-6"	22'-8"	21'-7 ⁽¹⁾	17'-11 ⁽¹⁾
	560	26'-0"	24'-2"	22'-11"	20'-4 ⁽¹⁾	27'-6"	25'-6"	24'-3 ⁽¹⁾	22'-1 ⁽¹⁾	25'-6"	23'-7"	22'-5"	20'-4 ⁽¹⁾	26'-11"	24'-11"	23'-8"	22'-1 ⁽¹⁾
16"	210	24'-7"	22'-10 ⁽¹⁾	19'-11 ⁽¹⁾	15'-10 ⁽¹⁾	25'-11"	22'-10 ⁽¹⁾	19'-11 ⁽¹⁾	15'-10 ⁽¹⁾	23'-9"	22'-1 ⁽¹⁾	19'-11 ⁽¹⁾	15'-10 ⁽¹⁾	25'-1"	22'-10 ⁽¹⁾	19'-11 ⁽¹⁾	15'-10 ⁽¹⁾
	230	25'-0"	23'-4 ⁽¹⁾	21'-4 ⁽¹⁾	17'-0 ⁽¹⁾	26'-5"	24'-0 ⁽¹⁾	21'-11 ⁽¹⁾	17'-7 ⁽¹⁾	24'-3"	22'-6"	21'-4 ⁽¹⁾	17'-0 ⁽¹⁾	25'-7"	23'-9 ⁽¹⁾	21'-11 ⁽¹⁾	17'-7 ⁽¹⁾
	360	25'-11"	24'-1 ⁽¹⁾	21'-9 ⁽¹⁾	17'-4 ⁽¹⁾	27'-4"	25'-6 ⁽¹⁾	22'-5 ⁽¹⁾	17'-11 ⁽¹⁾	25'-2"	23'-4"	21'-9 ⁽¹⁾	17'-4 ⁽¹⁾	26'-7"	24'-8 ⁽¹⁾	22'-5 ⁽¹⁾	17'-11 ⁽¹⁾
	560	28'-3"	26'-3"	25'-0 ⁽¹⁾	20'-4 ⁽¹⁾	29'-11"	27'-9"	26'-5 ⁽¹⁾	22'-1 ⁽¹⁾	27'-8"	25'-7"	24'-4 ⁽¹⁾	20'-4 ⁽¹⁾	29'-3"	27'-1"	25'-9 ⁽¹⁾	22'-1 ⁽¹⁾

(1) Web stiffeners are required at intermediate supports of continuous-span joists when the intermediate bearing length is less than 5¼" and the span on either side of the intermediate bearing is greater than the following spans:

TJI®	40 PSF Live Load / 15 PSF Dead Load				40 PSF Live Load / 30 PSF Dead Load				
	12" o.c.	16" o.c.	19.2" o.c.	24" o.c.	12" o.c.	16" o.c.	19.2" o.c.	24" o.c.	
110	Not Required	Not Required	19'-3"	15'-4"	Not Required	Not Required	18'-8"	15'-6"	12'-5"
210			21'-4"	17'-1"			20'-8"	17'-3"	13'-9"
230			19'-2"	15'-5"			23'-3"	19'-4"	15'-5"
360			19'-7"	15'-10"			23'-9"	19'-9"	15'-10"
560			23'-11"	19'-3"			24'-2"	19'-3"	19'-3"

To more accurately predict floor performance, use our TJI-Pro™ Ratings

• **Bold italic** spans indicate floors that would meet National Building Code of Canada (NBCC) vibration criteria but would be considered by 35% of the population to have marginal or unacceptable performance.

See pages 7 and 8 for how to use these tables and General Notes.

These Conditions Are NOT Permitted:



DO NOT use sawn lumber for rim board or blocking as it may shrink after installation. Use only engineered lumber

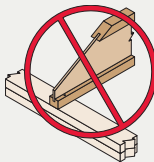

DO NOT bevel cut joist beyond inside face of wall.



DO NOT install hanger overhanging face of plate or beam. Flush bearing plate with inside face of wall or beam.

ALLOWABLE HOLES

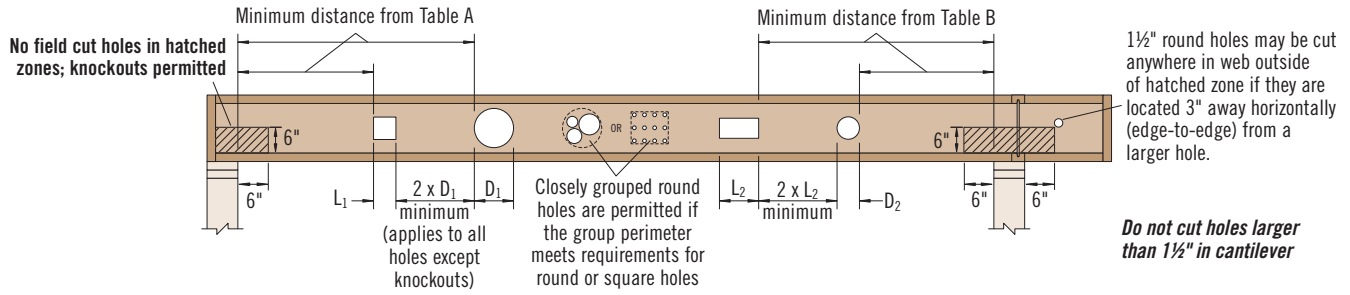

Table A—End Support (Minimum distance from edge of hole to inside face of nearest end support)

Depth	TJI®	● Round Hole Size									■ Square or Rectangular Hole Size								
		2"	3"	4"	5"	6 1/2"	7"	8 7/8"	11"	13"	2"	3"	4"	5"	6 1/2"	7"	8 7/8"	11"	13"
9 1/2"	110	1'-0"	1'-6"	2'-0"	3'-0"	5'-0"					1'-0"	1'-6"	2'-6"	3'-6"	4'-6"				
	210	1'-0"	1'-6"	2'-6"	3'-0"	5'-6"					1'-0"	2'-0"	2'-6"	4'-0"	5'-0"				
	230	1'-6"	2'-0"	2'-6"	3'-6"	5'-6"					1'-0"	2'-0"	3'-0"	4'-6"	5'-0"				
	360	1'-6"	2'-0"	3'-0"	4'-0"	6'-0"					1'-6"	2'-6"	3'-6"	5'-0"	5'-6"				
	560	1'-6"	2'-6"	3'-6"	5'-0"	7'-0"					2'-0"	3'-0"	4'-0"	5'-6"	6'-0"				
11 7/8"	110	1'-0"	1'-0"	1'-6"	2'-0"	2'-6"	3'-0"	5'-6"			1'-0"	1'-6"	2'-0"	2'-6"	4'-6"	5'-0"	6'-0"		
	210	1'-0"	1'-6"	2'-0"	2'-0"	3'-0"	3'-6"	6'-0"			1'-0"	1'-6"	2'-6"	3'-0"	5'-0"	5'-6"	6'-6"		
	230	1'-0"	1'-6"	2'-0"	2'-6"	3'-0"	3'-6"	6'-6"			1'-0"	2'-0"	2'-6"	3'-6"	5'-6"	5'-6"	7'-0"		
	360	1'-6"	2'-0"	3'-0"	3'-6"	4'-6"	5'-0"	7'-0"			1'-6"	2'-6"	3'-6"	4'-6"	6'-6"	6'-6"	7'-6"		
	560	1'-6"	2'-6"	3'-0"	4'-0"	5'-6"	6'-0"	8'-0"			2'-6"	3'-6"	4'-6"	5'-6"	7'-0"	7'-6"	8'-0"		
14"	110	1'-0"	1'-0"	1'-0"	1'-6"	1'-6"	2'-0"	3'-0"	5'-6"		1'-0"	1'-0"	1'-6"	2'-0"	3'-6"	4'-6"	4'-6"	8'-0"	8'-0"
	210	1'-0"	1'-0"	1'-0"	1'-6"	2'-0"	2'-6"	3'-6"	6'-0"		1'-0"	1'-0"	2'-0"	2'-6"	4'-0"	4'-6"	6'-6"	8'-6"	
	230	1'-0"	1'-0"	1'-0"	1'-6"	2'-6"	2'-6"	4'-0"	7'-0"		1'-0"	1'-0"	2'-0"	3'-0"	4'-0"	5'-0"	7'-0"	9'-0"	
	360	1'-0"	1'-0"	1'-6"	2'-6"	3'-6"	4'-0"	5'-6"	8'-0"		1'-0"	1'-6"	2'-6"	4'-0"	6'-0"	6'-6"	8'-0"	9'-6"	
	560	1'-0"	1'-0"	2'-0"	3'-0"	4'-6"	5'-0"	6'-6"	9'-0"		1'-6"	3'-0"	4'-0"	5'-0"	7'-0"	7'-6"	9'-0"	10'-0"	
16"	210	1'-0"	1'-0"	1'-0"	1'-0"	1'-0"	1'-6"	2'-6"	3'-6"	6'-0"	1'-0"	1'-0"	1'-0"	2'-0"	3'-0"	3'-6"	6'-6"	8'-0"	11'-0"
	230	1'-0"	1'-0"	1'-0"	1'-0"	1'-6"	1'-6"	3'-0"	4'-0"	7'-0"	1'-0"	1'-0"	2'-0"	3'-6"	4'-6"	4'-6"	6'-0"	9'-0"	11'-0"
	360	1'-0"	1'-0"	1'-0"	1'-0"	2'-6"	2'-6"	4'-6"	6'-6"	9'-0"	1'-0"	1'-0"	1'-6"	3'-0"	5'-0"	5'-6"	9'-0"	10'-0"	11'-6"
	560	1'-0"	1'-0"	1'-0"	1'-0"	2'-6"	3'-0"	5'-0"	7'-6"	10'-0"	1'-0"	2'-0"	3'-0"	4'-6"	6'-6"	7'-0"	10'-0"	11'-0"	12'-0"

Table B—Intermediate or Cantilever Support (Minimum distance from edge of hole to inside face of nearest intermediate or cantilever support)

Depth	TJI®	● Round Hole Size									■ Square or Rectangular Hole Size								
		2"	3"	4"	5"	6 1/2"	7"	8 7/8"	11"	13"	2"	3"	4"	5"	6 1/2"	7"	8 7/8"	11"	13"
9 1/2"	110	2'-0"	2'-6"	3'-6"	4'-6"	7'-6"					1'-6"	2'-6"	3'-6"	5'-6"	6'-6"				
	210	2'-0"	2'-6"	3'-6"	5'-0"	8'-0"					2'-0"	3'-0"	4'-0"	6'-6"	7'-6"				
	230	2'-6"	3'-0"	4'-0"	5'-6"	8'-6"					2'-0"	3'-6"	4'-6"	6'-6"	7'-6"				
	360	3'-0"	4'-0"	5'-6"	6'-6"	9'-0"					3'-0"	4'-6"	5'-6"	7'-6"	8'-0"				
	560	3'-6"	5'-0"	6'-0"	7'-6"	10'-0"					4'-0"	5'-6"	6'-6"	8'-0"	9'-0"				
11 7/8"	110	1'-0"	1'-0"	1'-6"	2'-6"	4'-0"	4'-6"	8'-6"			1'-0"	1'-6"	2'-6"	4'-0"	7'-0"	7'-0"	9'-6"		
	210	1'-0"	1'-0"	2'-0"	3'-0"	4'-6"	5'-0"	9'-0"			1'-0"	2'-0"	3'-0"	4'-6"	8'-0"	8'-0"	10'-0"		
	230	1'-0"	2'-0"	2'-6"	3'-6"	5'-0"	5'-6"	10'-0"			1'-0"	2'-6"	3'-6"	5'-0"	8'-6"	9'-0"	10'-6"		
	360	2'-0"	3'-0"	4'-0"	5'-6"	7'-0"	7'-6"	11'-0"			2'-0"	3'-6"	5'-0"	7'-0"	9'-6"	9'-6"	11'-0"		
	560	1'-6"	3'-0"	4'-6"	5'-6"	8'-0"	8'-6"	12'-0"			3'-0"	4'-6"	6'-0"	8'-0"	10'-6"	11'-0"	12'-0"		
14"	110	1'-0"	1'-0"	1'-0"	1'-0"	2'-0"	2'-6"	4'-6"	8'-6"		1'-0"	1'-0"	1'-0"	2'-6"	5'-0"	6'-0"	9'-0"	12'-0"	
	210	1'-0"	1'-0"	1'-0"	1'-0"	2'-6"	3'-0"	5'-6"	9'-6"		1'-0"	1'-0"	2'-0"	3'-6"	6'-0"	7'-0"	10'-0"	13'-0"	
	230	1'-0"	1'-0"	1'-0"	2'-0"	3'-6"	4'-0"	6'-0"	10'-6"		1'-0"	1'-0"	2'-6"	4'-0"	6'-6"	7'-6"	11'-0"	13'-6"	
	360	1'-0"	1'-0"	2'-0"	3'-6"	5'-6"	6'-0"	8'-6"	12'-6"		1'-0"	2'-0"	4'-0"	5'-6"	9'-0"	10'-0"	12'-0"	14'-0"	
	560	1'-0"	1'-0"	1'-6"	3'-6"	5'-6"	6'-6"	9'-6"	13'-6"		1'-0"	3'-0"	5'-0"	7'-0"	10'-0"	11'-0"	13'-6"	15'-0"	
16"	210	1'-0"	1'-0"	1'-0"	1'-0"	1'-0"	1'-0"	3'-6"	6'-0"	10'-0"	1'-0"	1'-0"	1'-0"	1'-6"	4'-6"	5'-6"	10'-0"	12'-6"	16'-0"
	230	1'-0"	1'-0"	1'-0"	1'-0"	1'-6"	2'-0"	4'-0"	6'-6"	11'-0"	1'-0"	1'-0"	2'-6"	5'-0"	6'-0"	10'-6"	13'-6"	16'-6"	
	360	1'-0"	1'-0"	1'-0"	1'-0"	3'-0"	4'-0"	6'-6"	10'-0"	13'-6"	1'-0"	1'-0"	2'-0"	4'-0"	7'-6"	8'-6"	13'-0"	14'-6"	17'-0"
	560	1'-0"	1'-0"	1'-0"	1'-0"	2'-6"	3'-6"	7'-0"	11'-0"	15'-0"	1'-0"	1'-0"	3'-6"	5'-6"	9'-0"	10'-0"	14'-6"	16'-0"	18'-0"

• Rectangular holes based on measurement of longest side.

General Notes

- Holes may be located vertically anywhere within the web. Leave 1/8" of web (minimum) at top and bottom of hole.
- Knockouts are located in web at approximately 12" on-centre; they do not affect hole placement and may be located in the hatched zone.
- For simple span (5' minimum) uniformly loaded joists meeting the requirements of this guide, one maximum size round hole may be located at the centre of the joist span **provided that no other holes occur in the joist.**
- Distances are based on the maximum uniform loads shown in this guide. For other load conditions or hole configurations use ForteWEB® software or contact your Weyerhaeuser representative.

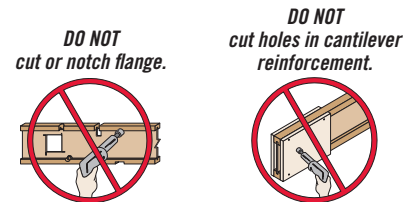

See page 20 for how to use these tables.

Maximum Hole at Mid-Span for TJI® 360 and TJI® 560 Joists

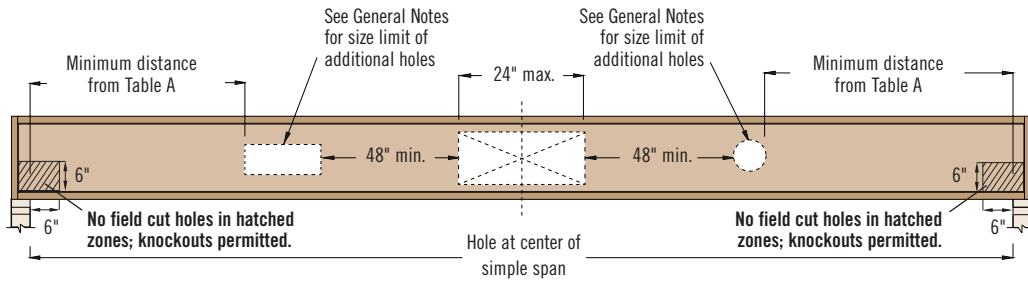

Maximum Hole at Mid-Span for TJI® 360 and TJI® 560 Joists

Depth	TJI®	Maximum Hole Size (height x length)
11 1/2"	360	6 7/8" x 24"
	560	8 7/8" x 24"
14"	360	9" x 24"
	560	11" x 24"
16"	360	11" x 24"
	560	13" x 24"

General Notes

- Simple span (8' minimum) uniformly loaded joist only. Not for use in applications that have code mandated concentrated load requirements.
- 24" wide hole (maximum) located at center of span.
- Leave 1/8" of web (minimum) at top and bottom of hole.
- Two (2) additional holes may be added to the joist provided:
 - Additional holes are a minimum of 48" (edge to edge) from maximum hole.
 - Square or Rectangular: longest dimension is less than or equal to 0.65 x web depth.
 - Round: diameter is less than or equal 0.75 x web depth.
 - Web depth (in.) = joist depth (in.) - 2.75".
 - See **Table A** for proper hole placement from end bearing for additional holes.



WARNING: This product can expose you to chemicals including wood dust which are known to the State of California to cause cancer, and methanol, which are known to the State of California to cause birth defects or other reproductive harm. Drilling, sawing, sanding or machining wood products can expose you to wood dust. Avoid inhaling wood dust or use a dust mask or other safeguards for personal protection. For more information go to www.P65Warnings.ca.gov and www.P65Warnings.ca.gov/wood.

Safety data sheets for all Weyerhaeuser wood products can be found on our website at: weyerhaeuser.com/sustainability/environment/product-stewardship/safety-data-sheets.

Cantilevers Less than 5" (Brick Ledge)

See Section A of cantilever table on page 13

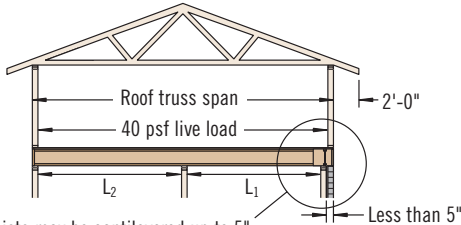

TJI® joists may be cantilevered up to 5" when supporting roof load, assuming:

- simple or continuous span
- $L_1 \leq L_2$
- minimum backspan = 2x cantilever length

Cantilevers 5" to 24"

See Section B of cantilever table on page 13

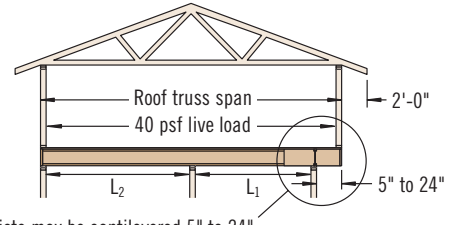

TJI® joists may be cantilevered 5" to 24" when supporting roof load, assuming:

- simple or continuous span
- $L_1 \leq L_2$
- minimum backspan = 2x cantilever length

PB1

Cantilever back span must be permanently braced with either direct-applied ceiling along entire length or permanent bracing at ⅓ points. See detail PB1 below for connections.

E1, E1W

Web stiffeners required both sides at E1W ONLY

8" diameter maximum hole for 1⅞"-16" deep blocking panels; 6" diameter maximum for blocking panels 9½" deep or shorter than 12" long. **Do not cut flanges.**

1⅞" TJI® Rim Board, 1¼" or 1½" TimberStrand® LSL, typical. Attach to joist with one (0.131" x 3") nail at top and bottom flanges.

E2, E3

4'-0" length of ¾" reinforcement on one side at E2, both sides at E3. Attach to joist flange with 8d (0.131" x 2½") nails at 6" on-centre. When reinforcing both sides, stagger nails.

1⅞" TJI® Rim Board, 1¼" or 1½" TimberStrand® LSL, typical. Nail with (0.131" x 3") nails, one each at top and bottom flange.

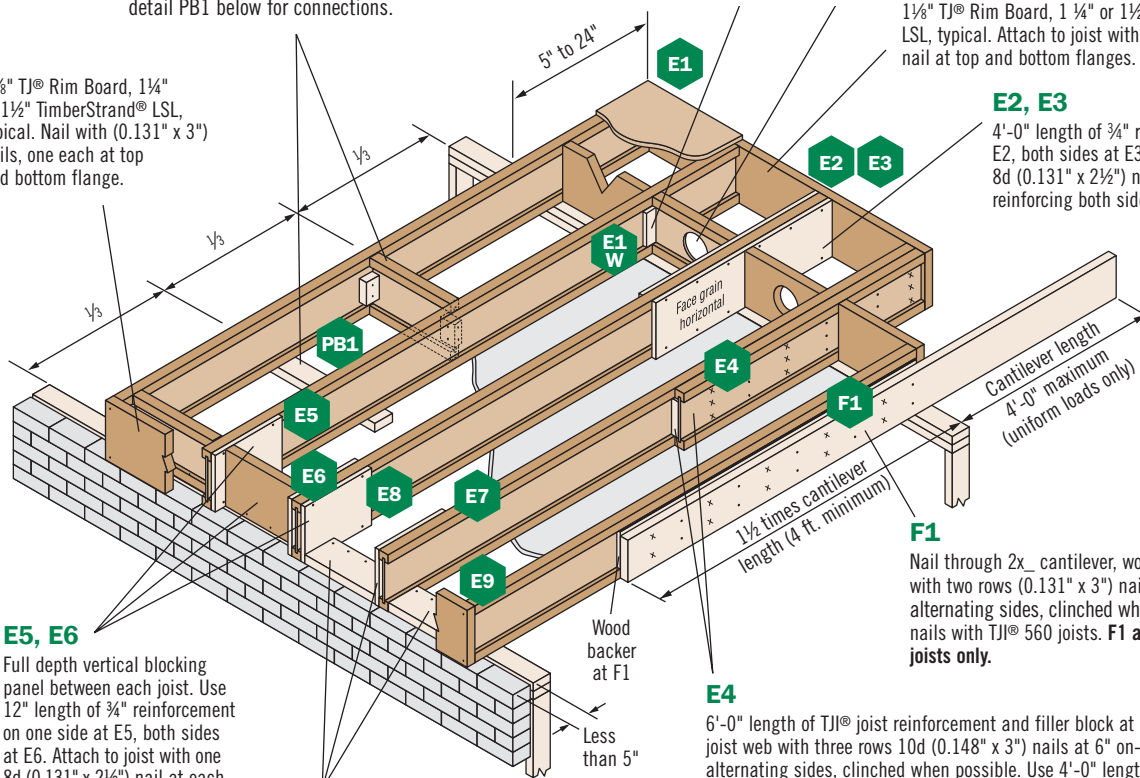

E5, E6

Full depth vertical blocking panel between each joist. Use 12" length of ¾" reinforcement on one side at E5, both sides at E6. Attach to joist with one 8d (0.131" x 2½") nail at each corner.

E7, E8, E9

Horizontal blocking panel between each joist. 12" length of ¾" reinforcement on one side with E7, both sides with E8. Attach to joist with one 8d (0.131" x 2½") nail at each corner. No reinforcement at E9. Nail rim to blocking panel and blocking panel to plate with connections equivalent to floor panel schedule.

E4

6'-0" length of TJI® joist reinforcement and filler block at E4. Attach to joist web with three rows 10d (0.148" x 3") nails at 6" on-centre from alternating sides, clinched when possible. Use 4'-0" length with 9½" and 11⅞" TJI® joists, and attach to joist web with two rows 10d (0.148" x 3") nails at 6" on-centre from alternating sides, clinched when possible. **Not for use with TJI® 560 joists.**

F1
Nail through 2x_ cantilever, wood backer, and TJI® joist web with two rows (0.131" x 3") nails at 6" on-centre, from alternating sides, clinched when possible. Use (0.131" x 3½") nails with TJI® 560 joists. **F1 applies to uniformly loaded joists only.**

TJI® joists are intended for dry-use applications

Details E2–E9 are not for use with joist depths > 16". See pages 23–24 for cantilevers using deeper joists.

For more information on details E1–E9, refer to our cover sheets and AutoCAD details online at weyerhaeuser.com/woodproducts/software-learning.

Apply subfloor adhesive to all contact surfaces

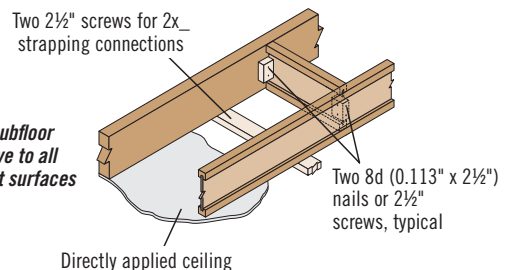

PB1

When specified on the layout, one of the above bracing options is required

Roof—Maximum Horizontal Clear Spans, Standard Term

O.C. Spacing	Depth	TJI®	Unfactored Snow Load (LL) and Dead Load (DL) in PSF								
			25LL + 15DL		30LL + 15DL		40LL + 15DL		50LL + 15DL		
			Low	High	Low	High	Low	High	Low	High	
16"	9½"	110	18'-0"	16'-8"	16'-11"	15'-8"	15'-3"	14'-2"	14'-1"	13'-1"	
		210	19'-0"	17'-8"	17'-10"	16'-7"	16'-2"	15'-0"	14'-11"	13'-11"	
		230	19'-8"	18'-3"	18'-6"	17'-2"	16'-8"	15'-6"	15'-5"	14'-4"	
		360	20'-11"	19'-5"	19'-8"	18'-3"	17'-9"	16'-6"	16'-5"	15'-3"	
	11⅞"	110	21'-6"	19'-11"	20'-2"	18'-9"	18'-3"	17'-0"	16'-11"	15'-8"	
		210	22'-9"	21'-1"	21'-4"	19'-10"	19'-3"	17'-11"	17'-10"	16'-7"	
		230	23'-5"	21'-9"	22'-0"	20'-5"	19'-11"	18'-6"	18'-5"	17'-2"	
		360	24'-11"	23'-2"	23'-5"	21'-9"	21'-2"	19'-8"	19'-7"	18'-3"	
	14"	110	24'-6"	22'-9"	23'-0"	21'-4"	20'-10"	19'-4"	19'-3"	17'-11"	
		210	25'-10"	24'-0"	24'-3"	22'-6"	21'-11"	20'-5"	20'-4"	18'-11"	
		230	26'-8"	24'-9"	25'-1"	23'-3"	22'-8"	21'-1"	20'-11"	19'-6"	
		360	28'-4"	26'-4"	26'-7"	24'-9"	24'-1"	22'-5"	22'-3"	20'-9"	
	16"	210	28'-8"	26'-7"	26'-11"	25'-0"	24'-4"	22'-8"	22'-6"	21'-0"	
		230	29'-7"	27'-5"	27'-9"	25'-9"	25'-1"	23'-4"	23'-3"	21'-7"	
		360	31'-5"	29'-2"	29'-6"	27'-5"	26'-8"	24'-10"	24'-8"	22'-11"	
		560	36'-1"	33'-6"	33'-10"	31'-5"	30'-8"	28'-6"	28'-4"	26'-4"	
	19.2"	9½"	110	16'-11"	15'-8"	15'-10"	14'-9"	14'-4"	13'-4"	13'-3"	12'-4"
			210	17'-10"	16'-7"	16'-9"	15'-7"	15'-2"	14'-1"	14'-0"	13'-0"
			230	18'-6"	17'-2"	17'-4"	16'-1"	15'-8"	14'-7"	14'-5"	13'-6"
			360	19'-8"	18'-3"	18'-5"	17'-2"	16'-8"	15'-6"	15'-4"	14'-4"
11⅞"		110	20'-2"	18'-9"	18'-11"	17'-7"	17'-2"	15'-11"	15'-10"	14'-9"	
		210	21'-4"	19'-10"	20'-0"	18'-7"	18'-1"	16'-10"	16'-9"	15'-7"	
		230	22'-0"	20'-5"	20'-8"	19'-2"	18'-8"	17'-4"	17'-3"	16'-1"	
		360	23'-5"	21'-9"	22'-0"	20'-5"	19'-10"	18'-6"	18'-4"	17'-1"	
14"		110	22'-11"	21'-4"	21'-7"	20'-0"	19'-3"	18'-2"	16'-2"	16'-9"	
		210	24'-3"	22'-6"	22'-9"	21'-2"	20'-7"	19'-2"	17'-11"	17'-9"	
		230	25'-1"	23'-3"	23'-6"	21'-10"	21'-3"	19'-9"	19'-8"	18'-4"	
		360	26'-7"	24'-9"	25'-0"	23'-3"	22'-7"	21'-0"	20'-7"	19'-5"	
16"		210	30'-7"	28'-5"	28'-8"	26'-8"	25'-11"	24'-2"	24'-0"	22'-4"	
		230	26'-11"	25'-0"	25'-3"	23'-6"	22'-10"	21'-3"	21'-1"	19'-8"	
		360	29'-6"	27'-5"	27'-8"	25'-9"	24'-6"	23'-3"	20'-7"	20'-10"	
		560	33'-10"	31'-5"	31'-9"	29'-6"	28'-9"	26'-9"	25'-1"	24'-5"	
24"		9½"	110	15'-7"	14'-6"	14'-8"	13'-7"	13'-3"	12'-4"	12'-3"	11'-5"
			210	16'-6"	15'-4"	15'-6"	14'-5"	14'-0"	13'-0"	12'-11"	12'-0"
			230	17'-1"	15'-10"	16'-0"	14'-11"	14'-5"	13'-6"	13'-4"	12'-5"
			360	18'-2"	16'-11"	17'-0"	15'-10"	15'-4"	14'-4"	14'-2"	13'-3"
	11⅞"	110	20'-11"	19'-5"	19'-7"	18'-3"	17'-8"	16'-6"	16'-4"	15'-3"	
		210	18'-8"	17'-4"	17'-6"	16'-4"	15'-4"	14'-9"	12'-11"	13'-8"	
		230	19'-9"	18'-4"	18'-6"	17'-3"	16'-9"	15'-7"	14'-4"	14'-5"	
		360	20'-4"	18'-11"	19'-1"	17'-9"	17'-3"	16'-1"	15'-11"	14'-10"	
	14"	110	21'-8"	20'-2"	20'-4"	18'-11"	18'-4"	17'-1"	16'-5"	15'-10"	
		210	24'-11"	23'-2"	23'-5"	21'-9"	21'-1"	19'-8"	19'-6"	18'-2"	
		230	24'-11"	23'-2"	23'-5"	21'-9"	21'-1"	19'-8"	19'-6"	18'-2"	
		360	24'-11"	23'-2"	23'-5"	21'-9"	21'-1"	19'-8"	19'-6"	18'-2"	
	16"	110	20'-6"	19'-7"	19'-0"	18'-6"	15'-4"	16'-5"	12'-11"	14'-0"	
		210	22'-5"	20'-10"	21'-1"	19'-7"	17'-1"	17'-9"	14'-4"	15'-6"	
		230	23'-2"	21'-6"	21'-9"	20'-3"	19'-2"	18'-4"	16'-1"	16'-4"	
		360	24'-7"	22'-11"	23'-1"	21'-6"	19'-7"	19'-5"	16'-5"	16'-8"	
	16"	210	28'-4"	26'-4"	26'-7"	24'-8"	23'-11"	22'-4"	20'-1"	19'-6"	
		230	23'-11"	23'-0"	21'-1"	21'-9"	17'-1"	18'-2"	14'-4"	15'-6"	
		360	25'-4"	23'-11"	23'-8"	22'-5"	19'-2"	19'-3"	16'-1"	16'-4"	
		560	27'-3"	25'-4"	24'-3"	23'-8"	19'-7"	19'-7"	16'-5"	16'-8"	
560	31'-4"	29'-1"	29'-5"	27'-4"	23'-11"	22'-11"	20'-1"	19'-6"			

How to Use This Table

1. Determine appropriate unfactored snow and dead load.
2. If your slope is 6:12 or less, use the **Low** slope column. If it is between 6:12 and 12:12, use the **High** column.
3. Scan down the column until you find a span that meets or exceeds the span of your application.
4. Select TJI® joist and on-centre spacing.

General Notes

- Table is based on:
 - Minimum bearing length of 1¾" end and 3½" intermediate, without web stiffeners.
 - Uniform loads.
 - More restrictive of simple or continuous span.
 - Minimum roof slope of ¼:12.
- Unfactored total load joist deflection limited to L/180.
- Unfactored live load joist deflection limited to L/360.
- For continuous spans, ratio of short span to long span should be 0.4 or greater to prevent uplift.
- A support beam or wall at the high end is required. Ridge board applications do not provide adequate support.
- For flat roofs or other loading conditions not shown, refer to Weyerhaeuser software.

Roof—Factored Resistance, Standard Term (PLF)

Depth	TJI®	Unfactored Deflection Resistance		Factored Strength Resistance	Unfactored Deflection Resistance		Factored Strength Resistance	Unfactored Deflection Resistance		Factored Strength Resistance	Unfactored Deflection Resistance		Factored Strength Resistance	Unfactored Deflection Resistance		Factored Strength Resistance	
		Live Load L/360	Total Load L/180	Total Load	Live Load L/360	Total Load L/180	Total Load	Live Load L/360	Total Load L/180	Total Load	Live Load L/360	Total Load L/180	Total Load	Live Load L/360	Total Load L/180	Total Load	
		Roof Joist Horizontal Clear Span															
		8'			10'			12'			14'			16'			
9½"	110	*	*	300	*	*	240	114	*	201	74	*	166	51	*	127	
	210	*	*	332	*	*	266	132	*	222	87	*	191	60	*	153	
	230	*	*	373	*	*	299	145	*	250	95	*	214	66	*	170	
	360	*	*	381	*	*	306	170	*	255	112	*	219	78	*	192	
	560	*	*	465	*	*	373	*	*	311	164	*	267	115	*	234	
11½"	110	*	*	300	*	*	240	*	*	201	*	*	172	85	*	151	
	210	*	*	332	*	*	266	*	*	222	*	*	191	98	*	167	
	230	*	*	373	*	*	299	*	*	250	*	*	214	107	*	188	
	360	*	*	381	*	*	306	*	*	255	*	*	219	127	*	192	
	560	*	*	465	*	*	373	*	*	311	*	*	267	*	*	234	
14"	110	*	*	300	*	*	240	*	*	201	*	*	172	*	*	151	
	210	*	*	332	*	*	266	*	*	222	*	*	191	*	*	167	
	230	*	*	373	*	*	299	*	*	250	*	*	214	*	*	188	
	360	*	*	381	*	*	306	*	*	255	*	*	219	*	*	192	
	560	*	*	465	*	*	373	*	*	311	*	*	267	*	*	234	
16"	210	*	*	332	*	*	266	*	*	222	*	*	191	*	*	167	
	230	*	*	373	*	*	299	*	*	250	*	*	214	*	*	188	
	360	*	*	381	*	*	306	*	*	255	*	*	219	*	*	192	
	560	*	*	465	*	*	373	*	*	311	*	*	267	*	*	234	
		18'			20'			22'			24'			26'			
9½"	110	36	*	101	27	54	81										
	210	43	*	121	31	63	98	24	48	81							
	230	47	*	134	35	70	109	26	53	90	20	41	76				
	360	56	112	171	41	83	154	31	63	129	24	49	109	19	39	93	
	560	83	*	208	62	124	188	47	95	171	37	74	156	29	59	143	
11½"	110	61	*	127	45	*	103	34	*	85							
	210	71	*	149	52	*	124	40	*	102	31	*	86				
	230	77	*	167	57	*	138	44	*	114	34	*	96	27	54	82	
	360	92	*	171	68	*	154	52	*	140	41	82	128	32	65	118	
	560	135	*	208	101	*	188	78	*	171	61	*	156	48	97	144	
14"	110	88	*	134	65	*	121	50	*	101	39	*	85				
	210	102	*	149	76	*	134	58	*	121	45	*	102	36	*	87	
	230	111	*	167	83	*	150	63	*	135	49	*	113	39	*	97	
	360	*	*	171	98	*	154	75	*	140	59	*	128	47	*	118	
	560	*	*	208	*	*	188	111	*	171	87	*	156	69	*	144	
16"	210	*	*	149	*	*	134	78	*	122	61	*	112	48	*	100	
	230	*	*	167	*	*	150	85	*	137	66	*	125	53	*	111	
	360	*	*	171	*	*	154	*	*	140	79	*	128	63	*	118	
	560	*	*	208	*	*	188	*	*	171	*	*	156	92	*	144	

* Indicates value does not control.

How to Use These Tables

1. Calculate actual factored total load and unfactored snow and total load on the joist in pounds per linear foot (plf).
2. Select appropriate **Roof Joist Horizontal Clear Span**. For slopes greater than 2:12, approximate the increased dead load by multiplying the joist horizontal clear span by the **Slope Factor shown on page 35**.
3. Scan down the columns to find a TJI® joist that meets or exceeds the actual unfactored snow and total loads, and the factored total load. All three columns must be checked.

General Notes

- Tables are based on:
 - Minimum bearing length of 1¾" end and 3½" intermediate, without web stiffeners
 - Uniform loads.
 - More restrictive of simple or continuous span.
 - Minimum roof slope of ¼:12.
 - No composite action provided by sheathing.



Single Joist, Top Mount



Single Joist, Face Mount

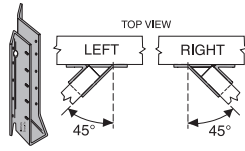

Face Mount Skewed 45° Joist Hanger

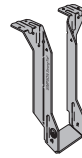

Double Joist, Top Mount



Double Joist, Face Mount

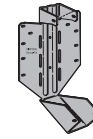

Variable Slope Seat Joist Hanger

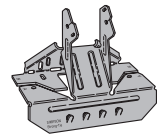

Variable Slope Seat Connector

Depth	TJI®	Single Joist—Top Mount				Single Joist—Face Mount				Face Mount Skewed 45° Joist Hanger			
		Hanger	Fac. Res. (lbs)	Nailing		Hanger	Fac. Res. (lbs)	Nailing		Hanger	Fac. Res. (lbs)	Nailing	
				Header	Joist			Header	Joist			Header	Joist
9 1/2"	110	ITS1.81/9.5	1,540	10d	N.A.	IUS1.81/9.5	1,540	10d	N.A.	<i>SUR/L1.81/9</i>	1,925	16d	10d x 1 1/2"
	210	ITS2.06/9.5	1,690	10d	N.A.	IUS2.06/9.5	1,690	10d	N.A.	<i>SUR/L2.1/9</i>	2,100	16d	10d x 1 1/2"
	230	ITS2.37/9.5	1,690	10d	N.A.	IUS2.37/9.5	1,690	10d	N.A.	<i>SUR/L2.37/9</i>	2,100	16d	10d x 1 1/2"
	360	ITS2.37/9.5	1,690	10d	N.A.	IUS2.37/9.5	1,690	10d	N.A.	<i>SUR/L2.37/9</i>	2,250	16d	10d x 1 1/2"
	560	ITS3.56/9.5	1,690	10d	N.A.	IUS3.56/9.5	1,685	10d	N.A.	<i>SUR/L410</i>	2,360	16d	16d
11 1/8"	110	ITS1.81/11.88	1,540	10d	N.A.	IUS1.81/11.88	1,540	10d	N.A.	<i>SUR/L1.81/11</i>	1,960	16d	10d x 1 1/2"
	210	ITS2.06/11.88	1,690	10d	N.A.	IUS2.06/11.88	1,690	10d	N.A.	<i>SUR/L2.1/11</i>	2,175	16d	10d x 1 1/2"
	230	ITS2.37/11.88	1,690	10d	N.A.	IUS2.37/11.88	1,770	10d	N.A.	<i>SUR/L2.37/11</i>	2,225	16d	10d x 1 1/2"
	360	ITS2.37/11.88	1,690	10d	N.A.	IUS2.37/11.88	1,805	10d	N.A.	<i>SUR/L2.37/11</i>	2,260	16d	10d x 1 1/2"
	560	ITS3.56/11.88	1,690	10d	N.A.	IUS3.56/11.88	1,685	10d	N.A.	<i>SUR/L410</i>	2,360	16d	16d
14"	110	ITS1.81/14	1,540	10d	N.A.	IUS1.81/14	1,540	10d	N.A.	<i>SUR/L1.81/14</i>	1,960	16d	10d x 1 1/2"
	210	ITS2.06/14	1,690	10d	N.A.	IUS2.06/14	1,690	10d	N.A.	<i>SUR/L2.1/14</i>	2,175	16d	10d x 1 1/2"
	230	ITS2.37/14	1,690	10d	N.A.	IUS2.37/14	1,770	10d	N.A.	<i>SUR/L2.37/14</i>	2,225	16d	10d x 1 1/2"
	360	ITS2.37/14	1,690	10d	N.A.	IUS2.37/14	1,805	10d	N.A.	<i>SUR/L2.37/14</i>	2,260	16d	10d x 1 1/2"
	560	ITS3.56/14	1,690	10d	N.A.	IUS3.56/14	1,685	10d	N.A.	<i>SUR/L414</i>	2,360	16d	16d
16"	210	ITS2.06/16	1,690	10d	N.A.	IUS2.06/16	1,690	10d	N.A.	<i>SUR/L2.1/16</i>	2,175	16d	10d x 1 1/2"
	230	ITS2.37/16	1,690	10d	N.A.	IUS2.37/16	1,770	10d	N.A.	<i>SUR/L2.37/16</i>	2,225	16d	10d x 1 1/2"
	360	ITS2.37/16	1,690	10d	N.A.	IUS2.37/16	1,805	10d	N.A.	<i>SUR/L2.37/16</i>	2,260	16d	10d x 1 1/2"
	560	ITS3.56/16	1,690	10d	N.A.	IUS3.56/16	1,685	10d	N.A.	<i>SUR/L414</i>	2,360	16d	16d

Depth	TJI®	Double Joist—Top Mount				Double Joist—Face Mount			
		Hanger	Fac. Res. (lbs)	Nailing		Hanger	Fac. Res. (lbs)	Nailing	
				Header	Joist			Header	Joist
9 1/2"	110	<i>MIT49.5</i>	2,420	16d	10d x 1 1/2"	<i>MIU3.56/9</i>	3,230	16d	10d x 1 1/2"
	210	<i>MIT4.28/9.5</i>	2,420	16d	10d x 1 1/2"	<i>MIU4.28/9</i>	3,230	16d	10d x 1 1/2"
	230	<i>MIT359.5-2</i>	2,420	16d	10d x 1 1/2"	<i>MIU4.75/9</i>	3,230	16d	10d x 1 1/2"
	360	<i>MIT359.5-2</i>	2,420	16d	10d x 1 1/2"	<i>MIU4.75/9</i>	3,230	16d	10d x 1 1/2"
	560	<i>HB7.12/9.5</i>	5,270	16d	16d	<i>HU410-2</i>	4,225	16d	16d
11 1/8"	110	<i>MIT411.88</i>	2,420	16d	10d x 1 1/2"	<i>MIU3.56/11</i>	3,230	16d	10d x 1 1/2"
	210	<i>MIT4.28/11.88</i>	2,420	16d	10d x 1 1/2"	<i>MIU4.28/11</i>	3,230	16d	10d x 1 1/2"
	230	<i>MIT3511.88-2</i>	2,420	16d	10d x 1 1/2"	<i>MIU4.75/11</i>	3,230	16d	10d x 1 1/2"
	360	<i>MIT3511.88-2</i>	2,420	16d	10d x 1 1/2"	<i>MIU4.75/11</i>	3,230	16d	10d x 1 1/2"
	560	<i>HB7.12/11.88</i>	5,450	16d	16d	<i>HU412-2</i>	4,225	16d	16d
14"	110	<i>MIT414</i>	2,420	16d	10d x 1 1/2"	<i>MIU3.56/14</i>	3,485	16d	10d x 1 1/2"
	210	<i>MIT4.28/14</i>	2,420	16d	10d x 1 1/2"	<i>MIU4.28/14</i>	3,485	16d	10d x 1 1/2"
	230	<i>MIT3514-2</i>	2,420	16d	10d x 1 1/2"	<i>MIU4.75/14</i>	3,485	16d	10d x 1 1/2"
	360	<i>MIT3514-2</i>	2,420	16d	10d x 1 1/2"	<i>MIU4.75/14</i>	3,485	16d	10d x 1 1/2"
	560	<i>HB7.12/14</i>	5,450	16d	16d	<i>HU414-2</i>	4,615	16d	16d
16"	210	<i>BA4.28/16</i>	4,200	16d	10d x 1 1/2"	<i>MIU4.28/16</i>	3,485	16d	10d x 1 1/2"
	230	<i>MIT4.75/16</i>	2,420	16d	10d x 1 1/2"	<i>MIU4.75/16</i>	3,485	16d	10d x 1 1/2"
	360	<i>MIT4.75/16</i>	2,420	16d	10d x 1 1/2"	<i>MIU4.75/16</i>	3,485	16d	10d x 1 1/2"
	560	<i>HB7.12/16</i>	5,450	16d	16d	<i>HU414-2</i>	4,615	16d	16d

TJI®	Variable Slope Seat Joist Hanger ⁽¹⁾				
	Hanger	Fac. Res. (lbs)		Nailing	
		Sloped Only	Sloped and Skewed	Header	Joist
110	<i>LSSR1.81Z</i>	1,485	1,200	10d	10d x 1 1/2"
210	<i>LSSR2.1Z</i>	1,560	1,200	10d	10d x 1 1/2"
230	<i>LSSR2.37Z</i>	1,560	1,200	10d	10d x 1 1/2"
360	<i>LSSR2.37Z</i>	1,560	1,200	10d	10d x 1 1/2"
560	<i>LSSR410Z</i>	2,045	1,835	16d	16d

TJI®	Variable Slope Seat Connector ⁽²⁾			
	Hanger	Fac. Res. (lbs)	Nailing	
			Header	Joist
110	VPA25	1,540	10d	10d x 1 1/2"
210	VPA2.1	1,690	10d	10d x 1 1/2"
230	VPA35	1,770	10d	10d x 1 1/2"
360	VPA35	1,805	10d	10d x 1 1/2"
560	VPA4	1,855	10d	10d x 1 1/2"

General Notes

Italic hangers require web stiffeners.

Factored resistances will vary with different nailing criteria or other support conditions; contact your Weyerhaeuser representative for assistance.

- Hanger factored resistances shown are either joist bearing or hanger factored resistance—whichever is less. Joist end reaction must be checked to ensure it does not exceed the factored resistance shown in the tables.
- All factored resistances are for downward loads, standard term.
- Fill all round, dimple, and positive-angle nail holes.
- Use sloped seat hangers and beveled web stiffeners when TJI® joist slope exceeds ¼:12.
- Leave 1/16" clearance (1/8" maximum) between the end of the supported joist and the header or hanger.
- Nails: 16d = 0.162" x 3 1/2", 10d = 0.148" x 3", and 10d x 1 1/2" = 0.148" x 1 1/2".

Support Requirements

- Support material assumed to be Trus Joist® engineered lumber or sawn lumber (Douglas fir, southern pine, or spruce-pine-fir species).
- Minimum support width for single- and double-joist top mount hangers is 3" (1 1/2" for ITS hangers).
- Minimum support width for face mount hangers with 10d and 16d nails (clinched) is 1 1/2" and 1 3/4", respectively.

See page 17 for table footnotes

FRAMING CONNECTORS (USP STRUCTURAL CONNECTORS®)

9½"-16"
JOISTS

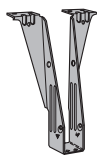

Single Joist, Top Mount

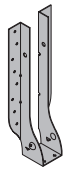

Single Joist, Face Mount

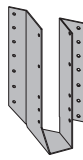

Face Mount Skewed 45° Joist Hanger

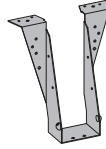

Double Joist, Top Mount

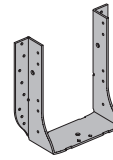

Double Joist, Face Mount

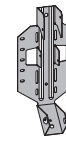

Variable Slope Seat Joist Hanger

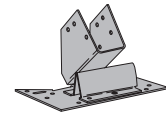

Variable Slope Seat Connector

Depth	TJI®	Single Joist—Top Mount				Single Joist—Face Mount				Face Mount Skewed 45° Joist Hanger			
		Hanger	Fac. Res. (lbs)	Nailing		Hanger	Fac. Res. (lbs)	Nailing		Hanger	Fac. Res. (lbs)	Nailing	
				Header	Joist			Header	Joist			Header	Joist
9½"	110	TH017950	1,540	10d	10d x 1½"	IHFL17925	1,750	10d	N.A.	SKH1720L/R	1,485	10d	10d x 1½"
	210	TFL2095	1,690	10d	10d x 1½"	IHFL20925	1,895	10d	N.A.	SKH2020L/R	1,640	10d	10d x 1½"
	230	TFL2395	1,770	10d	10d x 1½"	IHFL23925	1,960	10d	N.A.	SKH2320L/R	1,720	10d	10d x 1½"
	360	TFL2395	1,805	10d	10d x 1½"	IHFL23925	1,995	10d	N.A.	SKH2320L/R	1,755	10d	10d x 1½"
	560	TH035950	2,255	10d	10d x 1½"	IHFL35925	2,305	10d	N.A.	SKH410L/R ⁽³⁾	2,305	16d	16d
11½"	110	TH017118	1,540	10d	10d x 1½"	IHFL17112	1,750	10d	N.A.	SKH1720L/R	1,485	10d	10d x 1½"
	210	TFL20118	1,690	10d	10d x 1½"	IHFL20112	1,895	10d	N.A.	SKH2020L/R	1,640	10d	10d x 1½"
	230	TFL23118	1,770	10d	10d x 1½"	IHFL23112	1,960	10d	N.A.	SKH2320L/R	1,720	10d	10d x 1½"
	360	TFL23118	1,805	10d	10d x 1½"	IHFL23112	1,995	10d	N.A.	SKH2320L/R	1,755	10d	10d x 1½"
	560	TH035118	2,255	10d	10d x 1½"	IHFL35112	2,305	10d	N.A.	SKH410L/R ⁽³⁾	2,305	16d	16d
14"	110	TFL1714	1,540	10d	10d x 1½"	IHFL1714	1,750	10d	N.A.	SKH1720L/R	1,485	10d	10d x 1½"
	210	TFL2014	1,690	10d	10d x 1½"	IHFL2014	1,895	10d	N.A.	SKH2020L/R	1,640	10d	10d x 1½"
	230	TFL2314	1,770	10d	10d x 1½"	IHFL2314	1,960	10d	N.A.	SKH2324L/R	1,720	10d	10d x 1½"
	360	TFL2314	1,805	10d	10d x 1½"	IHFL2314	1,995	10d	N.A.	SKH2324L/R	1,755	10d	10d x 1½"
	560	TH035140	2,255	10d	10d x 1½"	IHFL3514	2,305	10d	N.A.	SKH414L/R ⁽³⁾	2,305	16d	16d
16"	210	TFL2016	1,690	10d	10d x 1½"	IHFL2016	1,895	10d	N.A.	SKH2024L/R	1,640	10d	10d x 1½"
	230	TFL2316	1,770	10d	10d x 1½"	IHFL2316	1,960	10d	N.A.	SKH2324L/R	1,720	10d	10d x 1½"
	360	TFL2316	1,805	10d	10d x 1½"	IHFL2316	1,995	10d	N.A.	SKH2324L/R	1,755	10d	10d x 1½"
	560	TH035160	2,255	10d	10d x 1½"	IHFL3516	2,305	10d	N.A.	SKH414L/R ⁽³⁾	2,305	16d	16d

Depth	TJI®	Double Joist—Top Mount				Double Joist—Face Mount			
		Hanger	Fac. Res. (lbs)	Nailing		Hanger	Fac. Res. (lbs)	Nailing	
				Header	Joist			Header	Joist
9½"	110	TH035950	2,620	10d	10d x 1½"	IHF35925	3,310	10d	10d x 1½"
	210	TH020950-2	3,320	16d	10d	IHF20925-2	2,900	10d	10d
	230	TH023950-2	4,200	16d	10d	IHF23925-2	2,900	10d	10d
	360	TH023950-2	4,375	16d	10d	IHF23925-2	2,900	10d	10d
	560	BPH7195	4,340	16d	10d	HD7100	4,180	16d	16d
11½"	110	TH035118	2,620	10d	10d x 1½"	IHF35112	3,310	10d	10d x 1½"
	210	TH020118-2	3,355	16d	10d	IHF20112-2	2,900	10d	10d
	230	TH023118-2	4,305	16d	10d	THF23118-2	3,920	10d	10d
	360	TH023118-2	4,375	16d	10d	THF23118-2	3,990	10d	10d
	560	BPH71118	4,305	16d	10d	HD7120	4,180	16d	16d
14"	110	TH035140	3,385	10d	10d x 1½"	IHF3514	3,310	10d	10d x 1½"
	210	TH020140-2	3,355	16d	10d	IHF2014-2	2,900	10d	10d
	230	TH023140-2	4,305	16d	10d	THF23140-2	3,920	10d	10d
	360	TH023140-2	4,375	16d	10d	THF23140-2	3,990	10d	10d
	560	BPH7114	4,305	16d	10d	HD7140	4,180	16d	16d
16"	210	TH020160-2	3,355	16d	10d	IHF2014-2	2,900	10d	10d
	230	TH023160-2	4,305	16d	10d	THF23160-2	3,920	10d	10d
	360	TH023160-2	4,375	16d	10d	THF23160-2	3,990	10d	10d
	560	BPH7116	4,305	16d	10d	HD7140	4,180	16d	16d

Hanger information on pages 16 and 17 was provided by either Simpson Strong-Tie® or USP Structural Connectors®. For additional information, please refer to their literature.

TJI®	Variable Slope Seat Joist Hanger ⁽¹⁾				
	Hanger	Fac. Res. (lbs)		Nailing	
		Sloped Only	Sloped and Skewed	Header	Joist
110	LSSH179	1,925	1,925	10d	10d x 1½"
210	LSSH20	1,990	1,990	10d	10d x 1½"
230	LSSH23	1,990	1,990	10d	10d x 1½"
360	LSSH23	1,990	1,990	10d	10d x 1½"
560	LSSH35	2,515	2,390	16d	10d x 1½"

TJI®	Variable Slope Seat Connector ⁽⁴⁾			
	Hanger	Fac. Res. (lbs)	Nailing	
			Header	Joist
110	TMP175	1,270	10d	10d x 1½"
	TMPH175	1,925	10d	10d x 1½"
210	TMP21	1,425	10d	10d x 1½"
	TMPH21	2,100	10d	10d x 1½"
230	TMP23	2,100	10d	10d x 1½"
	TMPH23	2,100	10d	10d x 1½"
360	TMP23	2,175	10d	10d x 1½"
	TMPH23	2,250	10d	10d x 1½"
560	TMP4	2,175	10d	10d x 1½"
	TMPH4	2,635	10d	10d x 1½"

Table footnotes for pages 16 and 17:

- (1) LSSR and LSSH hangers can be field adjusted for slopes and skews of up to 45 degrees. Additional lateral restraints are required for 16" deep TJI® joists.
- (2) VPA connectors are allowed on slopes of 3:12 through 12:12 only.
- (3) Miter cut is required at end of joist.
- (4) TMP connectors are allowed on slopes of 1:12 through 6:12 only, and TMPH connectors are allowed on slopes of 6:12 through 12:12 only.

See page 16 for General Notes

SECTION 2: 18"-24" TJI® JOISTS

This section contains design information for 18"-24" deep Trus Joist® TJI® joists used in residential, multi-family, or light-commercial applications.

18" and 20" deep TJI® joists are readily available through your local Weyerhaeuser dealer or distributor. Offered with the flange sizes shown below, they come in lengths up to 60' (in 1' increments). 22" and 24" deep TJI® joists are only available in some regions; for more information, contact your Weyerhaeuser representative.

Design Properties

Depth	TJI®	Joist Weight (lbs/ft)	Joist Only EI x 10 ⁶ (lbs-in. ²)	Factored Resistances—Standard Term							
				Maximum Resistive Moment ⁽¹⁾ (ft-lbs)	Maximum Vertical Shear (lbs)	1¾" End Reaction (lbs)		3½" Intermediate Reaction (lbs)		5¼" Intermediate Reaction (lbs)	
						No Web Stiffeners	With Web Stiffeners ⁽²⁾	No Web Stiffeners	With Web Stiffeners ⁽²⁾	No Web Stiffeners	With Web Stiffeners ⁽²⁾
18"	360	3.7	1,085	15,745	3,830	1,705	2,225	3,885	4,400	4,740	5,255
	560	4.8	1,631	24,205	4,785	1,995	2,680	4,735	5,425	5,455	6,140
20"	360	4.0	1,376	17,485	4,200	1,705	2,225	3,885	4,400	4,740	5,255
	560	5.1	2,064	26,890	5,280	1,995	2,680	4,735	5,425	5,455	6,140
22"	560D	5.6	2,606	30,060	5,690	N.A. ⁽³⁾	3,370	N.A. ⁽³⁾	7,255	N.A. ⁽³⁾	7,975
24"	560D	5.8	3,165	32,765	5,050	N.A. ⁽³⁾	3,370	N.A. ⁽³⁾	7,715	N.A. ⁽³⁾	8,430

- (1) **Caution:** Do not increase joist moment design properties by a repetitive-member-use factor.
- (2) See detail W on page 30 for web stiffener requirements and nailing information.
- (3) Web stiffeners are required at all bearing locations for 22" and 24" TJI® 560D joists.

General Notes

- Factored resistances are based on Limit States Design per CSA 086.
- Factored reaction includes all loads on the joist.
- Factored shear is computed at the inside face of supports and includes all loads on the span(s). Factored shear resistance may sometimes be increased at interior supports. For more information contact your Weyerhaeuser representative.
- The following formulas approximate the simple span uniform load deflection of Δ (inches):

For TJI® 360 Joists

$$\Delta = \frac{22.5 wL^4}{EI} + \frac{2.67 wL^2}{d \times 10^5}$$

For TJI® 560 and 560D Joists

$$\Delta = \frac{22.5 wL^4}{EI} + \frac{2.29 wL^2}{d \times 10^5}$$

w = uniform load in pounds per linear foot d = out-to-out depth of the joist in inches
L = span in feet EI = value from table above

TJI® joists are intended for dry-use applications

Some TJI® joist series may not be available in your region. Contact your Weyerhaeuser representative for information.

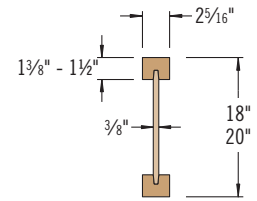

TJI® 360 joists

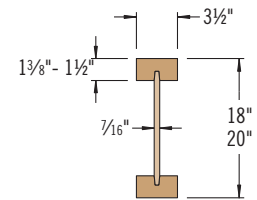

TJI® 560 joists

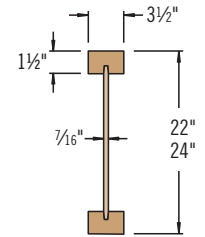

TJI® 560D Joist

FLOOR SPAN TABLES

5/8" OSB Subfloor (Glue-nailed)—Vibration-Controlled, Standard Term

Depth	TJI®	Directly Applied Ceiling				No Directly Applied Ceiling			
		Simple or Continuous Span		Continuous Span Only		Simple or Continuous Span		Continuous Span Only	
		16" o.c.	19.2" o.c.	16" o.c.	19.2" o.c.	16" o.c.	19.2" o.c.	16" o.c.	19.2" o.c.
40 PSF Live / 15 PSF Dead Load									
18"	360	23'-2"	22'-2"	24'-6"	23'-5"	22'-4"	21'-4"	23'-7"	22'-7"
	560	25'-4"	24'-1"	26'-9"	25'-6"	24'-6"	23'-5"	25'-11"	24'-9"
20"	360	24'-9"	23'-8"	26'-3"	25'-1" ⁽¹⁾	23'-10"	22'-9"	25'-3"	24'-1"
	560	27'-0"	25'-9"	28'-7"	27'-3"	26'-3"	25'-0"	27'-9"	26'-5"
22"	560D	28'-10"	27'-6"	30'-6"	29'-1"	28'-0"	26'-8"	29'-7"	28'-2"
24"	560D	30'-6"	29'-1"	32'-3"	30'-9"	29'-6"	28'-1"	31'-3"	29'-9"
40 PSF Live Load / 30 PSF Dead Load									
18"	360	23'-2"	21'-9" ⁽¹⁾	24'-6" ⁽¹⁾	22'-5" ⁽¹⁾	22'-4"	21'-4" ⁽¹⁾	23'-7"	22'-5" ⁽¹⁾
	560	25'-4"	24'-1"	26'-9"	25'-6" ⁽¹⁾	24'-6"	23'-5"	25'-11"	24'-9" ⁽¹⁾
20"	360	24'-9" ⁽¹⁾	21'-9" ⁽¹⁾	26'-3" ⁽¹⁾	22'-5" ⁽¹⁾	23'-10" ⁽¹⁾	21'-9" ⁽¹⁾	25'-3" ⁽¹⁾	22'-5" ⁽¹⁾
	560	27'-0"	25'-5" ⁽¹⁾	28'-7"	27'-3" ⁽¹⁾	26'-3"	25'-0" ⁽¹⁾	27'-9"	26'-5" ⁽¹⁾
22"	560D	28'-10"	27'-6"	30'-6"	29'-1"	28'-0"	26'-8"	29'-7"	28'-2"
24"	560D	30'-6"	29'-1"	32'-3"	30'-9"	29'-6"	28'-1"	31'-3"	29'-9"

To more accurately predict floor performance, use our TJ-Pro™ Ratings

- (1) Web stiffeners are required at intermediate supports of continuous-span joists when the intermediate bearing length is less than 5¼" and the span on either side of the intermediate bearing is greater than the following spans:

TJI®	40 PSF Live Load / 15 PSF Dead Load		40 PSF Live Load / 30 PSF Dead Load	
	16" o.c.	19.2" o.c.	16" o.c.	19.2" o.c.
360	Not Required	24'-6"	23'-9"	19'-9"
560				

- Bold italic** spans indicate floors that would meet National Building Code of Canada (NBCC) vibration criteria but would be considered by 35% of the population to have marginal or unacceptable performance.

See page 19 for how to use this table and General Notes.

3/4" OSB Subfloor (Glue-nailed)—Vibration-Controlled, Standard Term

Depth	TJI®	Directly Applied Ceiling						No Directly Applied Ceiling					
		Simple or Continuous Span			Continuous Span Only			Simple or Continuous Span			Continuous Span Only		
		16" o.c.	19.2" o.c.	24" o.c.	16" o.c.	19.2" o.c.	24" o.c.	16" o.c.	19.2" o.c.	24" o.c.	16" o.c.	19.2" o.c.	24" o.c.
40 PSF Live / 15 PSF Dead Load													
18"	360	24'-8" ⁽¹⁾	23'-6" ⁽¹⁾	21'-6" ⁽¹⁾	26'-1" ⁽¹⁾	24'-10" ⁽¹⁾	22'-2" ⁽¹⁾	23'-10"	22'-8"	21'-5" ⁽¹⁾	25'-2"	24'-0"	22'-2" ⁽¹⁾
	560	26'-10"	25'-7" ⁽¹⁾	24'-2" ⁽¹⁾	28'-5"	27'-0"	25'-7" ⁽¹⁾	26'-2"	24'-10"	23'-5"	27'-8"	26'-3"	24'-10" ⁽¹⁾
20"	360	26'-4"	25'-1" ⁽¹⁾	21'-6" ⁽¹⁾	27'-10"	26'-7" ⁽¹⁾	22'-2" ⁽¹⁾	25'-5"	24'-3"	21'-6" ⁽¹⁾	26'-11"	25'-7" ⁽¹⁾	22'-2" ⁽¹⁾
	560	28'-8"	27'-4"	25'-2" ⁽¹⁾	30'-4"	28'-11"	27'-3" ⁽¹⁾	27'-11"	26'-6"	25'-0" ⁽¹⁾	29'-6"	28'-1"	26'-6"⁽¹⁾
22"	560D	30'-7"	29'-1"	27'-6"	32'-4"	30'-10"	29'-1"	29'-9"	28'-3"	26'-8"	31'-6"	29'-11"	28'-3"
24"	560D	32'-4"	30'-9"	29'-0"	34'-9"	32'-6"	30'-9"	31'-5"	29'-10"	28'-2"	33'-6"	31'-7"	29'-9"
40 PSF Live Load / 30 PSF Dead Load													
18"	360	24'-8" ⁽¹⁾	21'-9" ⁽¹⁾	17'-4" ⁽¹⁾	26'-1" ⁽¹⁾	22'-5" ⁽¹⁾	17'-11" ⁽¹⁾	23'-10" ⁽¹⁾	21'-9" ⁽¹⁾	17'-4" ⁽¹⁾	25'-2" ⁽¹⁾	22'-5" ⁽¹⁾	17'-11" ⁽¹⁾
	560	26'-10"	25'-5" ⁽¹⁾	20'-4" ⁽¹⁾	28'-5"	27'-0" ⁽¹⁾	22'-1" ⁽¹⁾	26'-2"	24'-10" ⁽¹⁾	20'-4" ⁽¹⁾	27'-8"	26'-3" ⁽¹⁾	22'-1" ⁽¹⁾
20"	360	26'-1" ⁽¹⁾	21'-9" ⁽¹⁾	17'-4" ⁽¹⁾	26'-11" ⁽¹⁾	22'-5" ⁽¹⁾	17'-11" ⁽¹⁾	25'-5" ⁽¹⁾	21'-9" ⁽¹⁾	17'-4" ⁽¹⁾	26'-11" ⁽¹⁾	22'-5" ⁽¹⁾	17'-11" ⁽¹⁾
	560	28'-8"	25'-5" ⁽¹⁾	20'-4" ⁽¹⁾	30'-4" ⁽¹⁾	27'-8" ⁽¹⁾	22'-1" ⁽¹⁾	27'-11"	25'-5" ⁽¹⁾	20'-4" ⁽¹⁾	27'-8" ⁽¹⁾	22'-5" ⁽¹⁾	17'-11" ⁽¹⁾
22"	560D	30'-7"	29'-1"	27'-6"	32'-4"	30'-10"	29'-1"	29'-9"	28'-3"	26'-8"	31'-6"	29'-11"	28'-3"
24"	560D	32'-4"	30'-9"	29'-0"	34'-9"	32'-6"	30'-9"	31'-5"	29'-10"	28'-2"	33'-6"	31'-7"	29'-9"

7/8" OSB Subfloor (Glue-nailed)—Vibration-Controlled, Standard Term

Depth	TJI®	Directly Applied Ceiling						No Directly Applied Ceiling					
		Simple or Continuous Span			Continuous Span Only			Simple or Continuous Span			Continuous Span Only		
		16" o.c.	19.2" o.c.	24" o.c.	16" o.c.	19.2" o.c.	24" o.c.	16" o.c.	19.2" o.c.	24" o.c.	16" o.c.	19.2" o.c.	24" o.c.
40 PSF Live / 15 PSF Dead Load													
18"	360	26'-0"	24'-9" ⁽¹⁾	21'-6" ⁽¹⁾	27'-5"	26'-2" ⁽¹⁾	22'-2" ⁽¹⁾	25'-2"	23'-11"	21'-6" ⁽¹⁾	26'-7"	25'-3" ⁽¹⁾	22'-2" ⁽¹⁾
	560	28'-3"	26'-11"	25'-2" ⁽¹⁾	29'-11"	28'-5"	26'-10" ⁽¹⁾	27'-7"	26'-2"	24'-8" ⁽¹⁾	29'-2"	27'-8"	26'-0" ⁽¹⁾
20"	360	27'-9"	26'-6" ⁽¹⁾	21'-6" ⁽¹⁾	29'-4"	27'-9" ⁽¹⁾	22'-2" ⁽¹⁾	26'-10"	25'-7" ⁽¹⁾	21'-6" ⁽¹⁾	28'-5"	27'-0" ⁽¹⁾	22'-2" ⁽¹⁾
	560	30'-2"	28'-9"	25'-2" ⁽¹⁾	31'-11"	30'-5" ⁽¹⁾	27'-5" ⁽¹⁾	29'-5"	28'-0"	25'-2" ⁽¹⁾	31'-2"	29'-7"	27'-5" ⁽¹⁾
22"	560D	32'-2"	30'-8"	28'-10"	34'-7"	32'-5"	30'-6"	31'-5"	29'-10"	28'-0"	33'-5"	31'-6"	29'-8"
24"	560D	34'-6"	32'-4"	30'-6"	37'-2"	34'-10"	32'-3"	33'-5"	31'-6"	29'-7"	35'-11"	33'-7"	31'-3"
40 PSF Live Load / 30 PSF Dead Load													
18"	360	26'-0" ⁽¹⁾	21'-9" ⁽¹⁾	17'-4" ⁽¹⁾	26'-11" ⁽¹⁾	22'-5" ⁽¹⁾	17'-11" ⁽¹⁾	25'-2" ⁽¹⁾	21'-9" ⁽¹⁾	17'-4" ⁽¹⁾	26'-7" ⁽¹⁾	22'-5" ⁽¹⁾	17'-11" ⁽¹⁾
	560	28'-3"	25'-5" ⁽¹⁾	20'-4" ⁽¹⁾	29'-11" ⁽¹⁾	27'-8" ⁽¹⁾	22'-1" ⁽¹⁾	27'-7"	25'-5" ⁽¹⁾	20'-4" ⁽¹⁾	29'-2" ⁽¹⁾	27'-8" ⁽¹⁾	22'-1" ⁽¹⁾
20"	360	26'-1" ⁽¹⁾	21'-9" ⁽¹⁾	17'-4" ⁽¹⁾	26'-11" ⁽¹⁾	22'-5" ⁽¹⁾	17'-11" ⁽¹⁾	26'-1" ⁽¹⁾	21'-9" ⁽¹⁾	17'-4" ⁽¹⁾	26'-11" ⁽¹⁾	22'-5" ⁽¹⁾	17'-11" ⁽¹⁾
	560	30'-2" ⁽¹⁾	25'-5" ⁽¹⁾	20'-4" ⁽¹⁾	31'-11" ⁽¹⁾	27'-8" ⁽¹⁾	22'-1" ⁽¹⁾	29'-5" ⁽¹⁾	25'-5" ⁽¹⁾	20'-4" ⁽¹⁾	31'-2" ⁽¹⁾	27'-8" ⁽¹⁾	22'-1" ⁽¹⁾
22"	560D	32'-2"	30'-8"	28'-10"	34'-7"	32'-5"	29'-7"	31'-5"	29'-10"	28'-0"	33'-5"	31'-6"	29'-7"
24"	560D	34'-6"	32'-4"	30'-6"	37'-2"	34'-10"	31'-6"	33'-5"	31'-6"	29'-7"	35'-11"	33'-7"	31'-3"

(1) Web stiffeners are required at intermediate supports of continuous-span joists when the intermediate bearing length is less than 5/4" and the span on either side of the intermediate bearing is greater than the following spans:

TJI®	40 PSF Live Load / 15 PSF Dead Load			40 PSF Live Load / 30 PSF Dead Load		
	16" o.c.	19.2" o.c.	24" o.c.	16" o.c.	19.2" o.c.	24" o.c.
360	Not Required	24'-6"	19'-7"	23'-9"	19'-9"	15'-10"
560		29'-11"	23'-11"	29'-0"	24'-2"	19'-3"

▪ **Italic spans** indicate floors that would meet National Building Code of Canada (NBCC) vibration criteria but would be considered by 35% of the population to have marginal or unacceptable performance.

How to Use These Tables

- Determine the the subflooring thickness and applicable live and dead loads.
- Determine whether the ceiling will be directly applied and what the span condition is (simple or continuous).
- Select on-centre spacing.
- Scan down the column until you meet or exceed the span of your application.
- Select TJI® joist and depth.

General Notes

- Tables are based on:
 - Clear distance between supports.
 - 18" and 20" TJI® joists:** Minimum bearing length of 1 3/4" end (no web stiffeners) and 3 1/2" intermediate.
 - 22" and 24" TJI® joists:** Minimum bearing length of 1 3/4" end and 3 1/2" intermediate; web stiffeners required at all bearings.
 - Limit States Design per CSA O86.
 - Uniform loads.
 - Single layer of appropriate span-rated OSB.
 - NBCC vibration criteria as ratified by Canadian Construction Materials Centre (CCMC).
- Long term deflection under dead load, which includes the effect of creep, has not been considered.
- For continuous spans, ratio of short span to long span should be 0.4 or greater to prevent uplift.
- Spans generated from Weyerhaeuser software may exceed the spans shown in these tables because software reflects actual design conditions.
- For multi-family applications and other loading conditions not shown, refer to Weyerhaeuser software.

To more accurately predict floor performance, use our TJ-Pro™ Ratings

ALLOWABLE HOLES

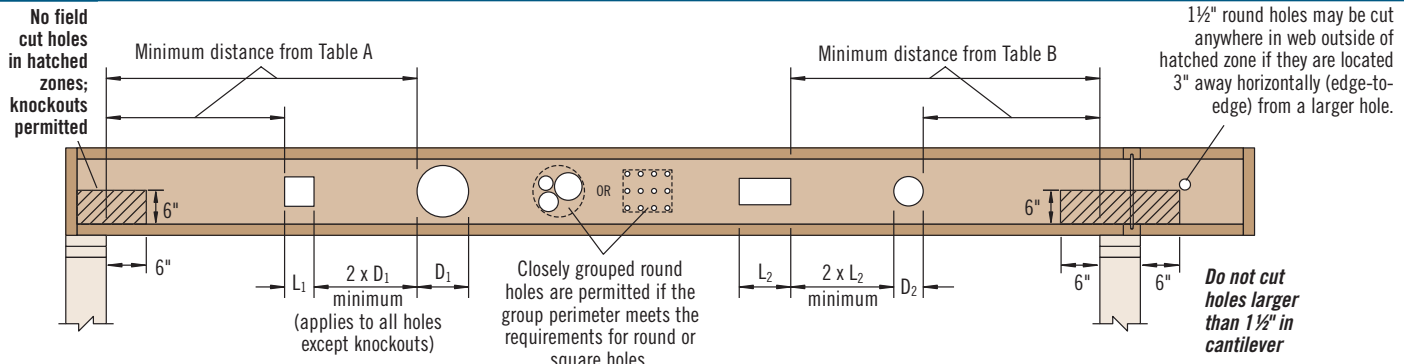

Table A—End Support (Minimum distance from edge of hole to inside face of nearest end support)

Depth	TJI®	● Round Hole Size										■ Square or Rectangular Hole Size									
		4"	5"	6"	6½"	7"	8"	10"	12"	14¾"	16¾"	4"	5"	6"	6½"	7"	8"	10"	12"	14¾"	16¾"
18"	360	1'-0"	1'-0"	1'-0"	1'-0"	1'-0"	2'-0"	4'-0"	5'-6"	9'-6"		1'-0"	1'-6"	3'-0"	4'-0"	4'-6"	6'-0"	10'-0"	11'-0"	13'-6"	
	560	1'-0"	1'-0"	1'-0"	1'-0"	1'-0"	2'-0"	4'-6"	7'-0"	10'-6"		2'-0"	3'-6"	5'-0"	5'-6"	6'-6"	8'-0"	11'-0"	12'-0"	14'-0"	
20"	360	1'-0"	1'-0"	1'-0"	1'-0"	1'-0"	1'-0"	2'-0"	4'-0"	7'-0"	10'-0"	1'-0"	1'-0"	1'-6"	2'-0"	3'-0"	4'-6"	8'-0"	11'-6"	13'-6"	15'-6"
	560	1'-0"	1'-0"	1'-0"	1'-0"	1'-0"	1'-0"	2'-0"	4'-6"	8'-6"	11'-0"	1'-0"	1'-6"	3'-6"	4'-6"	5'-0"	7'-0"	10'-6"	13'-0"	14'-6"	15'-6"
22"	560D	1'-0"	1'-0"	1'-0"	1'-0"	1'-0"	1'-6"	3'-6"	5'-0"	7'-0"	9'-6"	1'-0"	2'-6"	3'-6"	4'-6"	5'-0"	6'-6"	14'-6"	15'-0"	16'-0"	16'-6"
24"	560D	1'-0"	1'-0"	1'-0"	1'-0"	1'-6"	2'-0"	3'-6"	5'-0"	7'-0"	8'-6"	1'-6"	2'-6"	4'-0"	4'-6"	5'-0"	6'-6"	9'-6"	15'-0"	16'-0"	16'-6"

Table B—Intermediate or Cantilever Support (Minimum distance from edge of hole to inside face of nearest intermediate or cantilever support)

Depth	TJI®	● Round Hole Size										■ Square or Rectangular Hole Size									
		4"	5"	6"	6½"	7"	8"	10"	12"	14¾"	16¾"	4"	5"	6"	6½"	7"	8"	10"	12"	14¾"	16¾"
18"	360	1'-0"	1'-0"	1'-0"	1'-0"	1'-6"	3'-0"	6'-0"	9'-0"	14'-6"		1'-0"	1'-6"	4'-0"	5'-6"	6'-6"	9'-0"	14'-6"	16'-6"	19'-0"	
	560	1'-0"	1'-0"	1'-0"	1'-0"	1'-0"	2'-0"	6'-0"	10'-0"	15'-6"		1'-0"	3'-6"	6'-0"	7'-6"	8'-6"	11'-6"	16'-6"	18'-0"	19'-6"	
20"	360	1'-0"	1'-0"	1'-0"	1'-0"	1'-0"	1'-0"	3'-0"	6'-0"	11'-0"	15'-0"	1'-6"	2'-6"	4'-0"	7'-0"	8'-6"	12'-6"	16'-6"	19'-0"	20'-6"	
	560	1'-0"	1'-0"	1'-0"	1'-0"	1'-0"	1'-6"	5'-6"	11'-6"	15'-6"	15'-6"	1'-0"	1'-0"	3'-0"	4'-6"	6'-0"	8'-6"	14'-0"	17'-6"	19'-0"	20'-6"
22"	560D	1'-0"	1'-6"	2'-6"	3'-0"	3'-6"	4'-6"	6'-6"	8'-0"	11'-0"	14'-6"	3'-6"	5'-0"	6'-6"	7'-6"	8'-6"	10'-0"	19'-0"	20'-0"	21'-0"	21'-6"
24"	560D	2'-6"	3'-0"	4'-0"	4'-6"	5'-0"	5'-6"	7'-0"	8'-6"	11'-0"	13'-6"	5'-0"	6'-0"	7'-6"	8'-0"	9'-0"	10'-6"	14'-0"	20'-0"	21'-0"	21'-6"

▪ Rectangular holes based on measurement of longest side.

How to Use These Tables

- Using **Table A**, **Table B**, or both if required, determine the hole shape/size and select the TJI® joist and depth.
- Scan horizontally until you intersect the correct hole size column.
- Measurement shown is minimum distance from edge of hole to support.
- Maintain the required minimum distance from the end **and** the intermediate or cantilever support.

General Notes

- Holes may be located vertically anywhere within the web. Leave 1/8" of web (minimum) at top and bottom of hole.
- Knockouts are located in web at approximately 12" on-centre; they do not affect hole placement and may be located in the hatched zone.
- For simple span (5' minimum) uniformly loaded joists meeting the requirements of this guide, one maximum size round hole may be located at the centre of the joist span **provided that no other holes occur in the joist**.
- Distances are based on the maximum uniform loads shown in this guide. For other load conditions or hole configurations, use ForteWEB® software or contact your Weyerhaeuser representative.

Maximum Hole at Mid-Span for TJI® 360 and 560 Joists

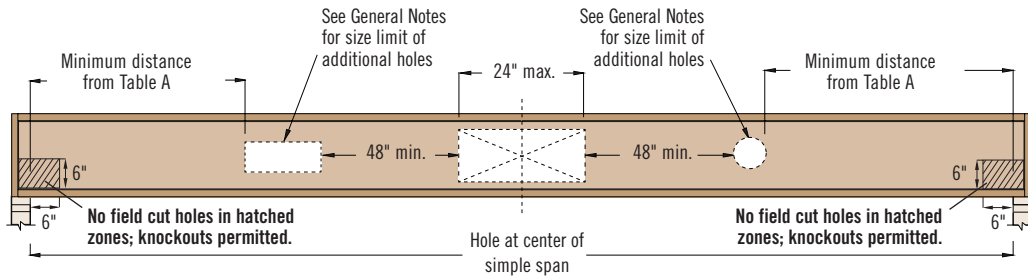

Maximum Hole at Mid-Span for TJI® 360 and TJI® 560 Joists

Depth	TJI®	Maximum Hole Size (height x length)
18"	360	13" x 24"
	560	15" x 24"
20"	360	15" x 24"
	560	17" x 24"

General Notes

- Simple span (8' minimum) uniformly loaded joist only. Not for use in applications that have code mandated concentrated load requirements.
- 24" wide hole (maximum) located at center of span.
- Leave 1/8" of web (minimum) at top and bottom of hole.
- Two (2) additional holes may be added to the joist provided:
 - Additional holes are a minimum of 48" (edge to edge) from maximum hole.
 - Square or Rectangular: longest dimension is less than or equal to 0.65 x web depth.
 - Round: diameter is less than or equal to 0.75 x web depth.
 - Web depth (in.) = joist depth (in.) - 2.75".
 - See **Table A** for proper hole placement from end bearing for additional holes.



WARNING: This product can expose you to chemicals including wood dust which are known to the State of California to cause cancer, and methanol, which are known to the State of California to cause birth defects or other reproductive harm. Drilling, sawing, sanding or machining wood products can expose you to wood dust. Avoid inhaling wood dust or use a dust mask or other safeguards for personal protection. For more information go to www.P65Warnings.ca.gov and www.P65Warnings.ca.gov/wood.

Safety data sheets for all Weyerhaeuser wood products can be found on our website at: weyerhaeuser.com/sustainability/environment/product-stewardship/safety-data-sheets.

Maximum Horizontal Clear Spans—Roof (slopes of 3:12 or less)

O.C. Spacing	Depth	TJI®	Unfactored Snow Load (LL) and Dead Load (DL) in PSF			
			25LL + 15DL	30LL + 15DL	40LL + 15DL	50LL + 15DL
16"	18"	360	35'-3"	33'-1"	29'-6"	24'-9"
		560	40'-5"	37'-11"	34'-4"	30'-2"
	20"	360	38'-2"	35'-10"	29'-6"	24'-9"
		560	43'-9"	41'-1"	35'-11"	30'-2"
	24"	560D	47'-4"	44'-5"	40'-2"	37'-2"
		560D	50'-6"	47'-5"	42'-11"	39'-8"
19.2"	18"	360	33'-1"	30'-4"	24'-6"	20'-7"
		560	37'-11"	35'-7"	29'-11"	25'-1"
	20"	360	34'-5"	30'-4"	24'-6"	20'-7"
		560	41'-1"	37'-0"	29'-11"	25'-1"
	24"	560D	44'-5"	41'-8"	37'-8"	34'-10"
		560D	47'-5"	44'-6"	40'-3"	37'-3"
24"	18"	360	27'-6"	24'-3"	19'-7"	16'-5"
		560	33'-6"	29'-7"	23'-11"	20'-1"
	20"	360	27'-6"	24'-3"	19'-7"	16'-5"
		560	33'-6"	29'-7"	23'-11"	20'-1"
	24"	560D	41'-1"	38'-7"	34'-10"	30'-10"
		560D	43'-11"	41'-2"	37'-3"	32'-9"

How to Use This Table

- Determine appropriate unfactored snow and dead load.
- Scan down the column until you find a span that meets or exceeds the span of your application.
- Select TJI® joist and on-centre spacing.

General Notes

- Table is based on:
 - 18" and 20" TJI® joists: Minimum bearing length of 1¾" end and 3½" intermediate (no web stiffeners).
 - 22" and 24" TJI® joists: Minimum bearing length of 1¾" end and 3½" intermediate; web stiffeners required at all bearings.
 - Uniform loads.
 - More restrictive of simple or continuous span.
 - Roof slopes of ¼:12 minimum, 3:12 maximum.
- Unfactored total load joist deflection limited to L/180.
- Unfactored live load joist deflection limited to L/360.
- For continuous spans, ratio of short span to long span should be 0.4 or greater to prevent uplift.
- A support beam or wall at the high end is required. Ridge board applications do not provide adequate support.
- For flat roofs or other loading conditions not shown, refer to Weyerhaeuser software.

ROOF LOAD TABLE

Roof—Factored Resistance, Standard Term (PLF) (slopes of 3:12 or less)

Depth	TJI®	Unfactored Deflection Resistance		Factored Strength Resistance	Unfactored Deflection Resistance		Factored Strength Resistance	Unfactored Deflection Resistance		Factored Strength Resistance	Unfactored Deflection Resistance		Factored Strength Resistance	Unfactored Deflection Resistance		Factored Strength Resistance
		Live Load L/360	Total Load L/180	Total Load	Live Load L/360	Total Load L/180	Total Load	Live Load L/360	Total Load L/180	Total Load	Live Load L/360	Total Load L/180	Total Load	Live Load L/360	Total Load L/180	Total Load
		Roof Joist Horizontal Clear Span														
		12'			14'			16'			18'			20'		
18"	360	*	*	255	*	*	219	*	*	192	*	*	171	*	*	154
	560	*	*	311	*	*	267	*	*	234	*	*	208	*	*	188
20"	360	*	*	255	*	*	219	*	*	192	*	*	171	*	*	154
	560	*	*	311	*	*	267	*	*	234	*	*	208	*	*	188
22"	560D	*	*	477	*	*	410	*	*	359	*	*	319	*	*	288
24"	560D	*	*	508	*	*	436	*	*	382	*	*	340	*	*	306
		22'			24'			26'			28'			30'		
18"	360	*	*	140	*	*	128	81	*	118	66	*	110	54	*	103
	560	*	*	171	*	*	156	*	*	144	*	*	134	80	*	125
20"	360	*	*	140	*	*	128	*	*	118	*	*	110	68	*	103
	560	*	*	171	*	*	156	*	*	144	*	*	134	*	*	125
22"	560D	*	*	262	*	*	240	*	*	221	*	*	206	124	*	192
24"	560D	*	*	278	*	*	255	*	*	236	*	*	219	*	*	204

* Indicates value does not control.

How to Use This Table

- Calculate actual factored total load and unfactored snow and total load on the joist in pounds per linear foot (plf).
- Select appropriate **Roof Joist Horizontal Clear Span**. For slopes greater than 2:12 (up to a maximum of 3:12), approximate the increased dead load by multiplying the joist horizontal clear span by the **Slope Factor** on page 35.
- Scan down the columns to find a TJI® joist that meets or exceeds the actual unfactored snow and total loads, and the factored total load. All three columns must be checked.

General Notes

- Table is based on:
 - 18" and 20" TJI® joists: Minimum bearing length of 1¾" end (no web stiffeners) and 3½" intermediate.
 - 22" and 24" TJI® joists: Minimum bearing length of 1¾" end and 3½" intermediate; web stiffeners required at all bearings.
 - Uniform loads.
 - More restrictive of simple or continuous span.
 - Roof slopes of ¼:12 minimum, 3:12 maximum.
 - No composite action provided by sheathing.

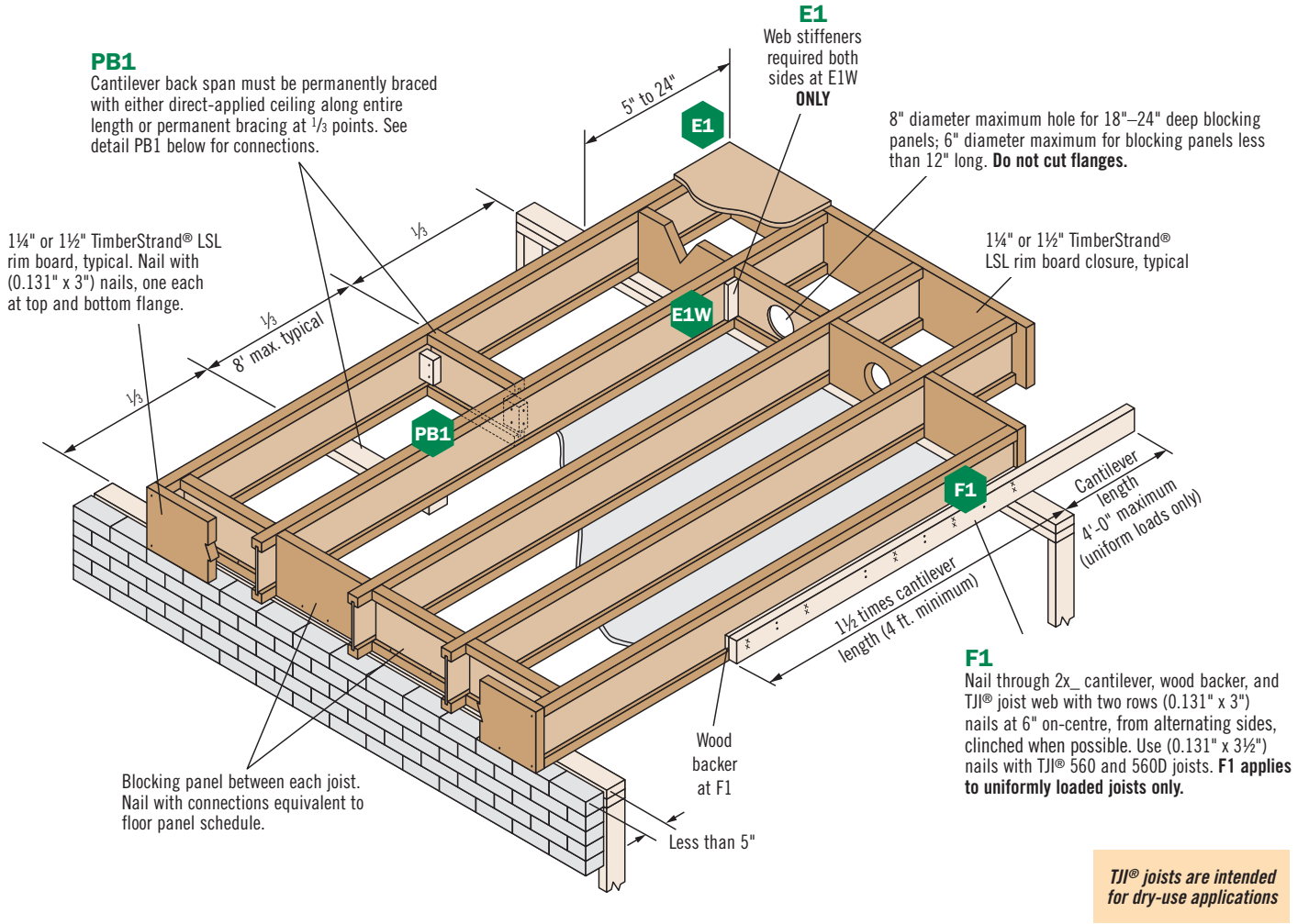

For E1 and E1W details, also refer to our cover sheets and AutoCAD details online at weyerhaeuser.com/woodproducts/software-learning

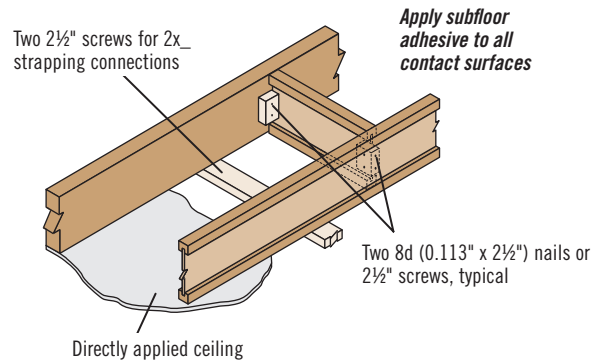

PB1 When specified in design software or layouts, one of the above bracing options is required

These Conditions Are NOT Permitted:



DO NOT use sawn lumber for rim board or blocking as it may shrink after installation. Use only engineered lumber

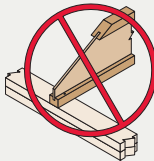

DO NOT bevel cut joist beyond inside face of wall.



DO NOT install hanger overhanging face of plate or beam. Flush bearing plate with inside face of wall or beam.



Single Joist,
Top Mount



Single Joist,
Face Mount

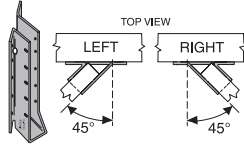

Face Mount Skewed 45°
Joist Hanger



Double Joist,
Top Mount



Double Joist,
Face Mount

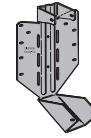

Variable Slope Seat
Joist Hanger

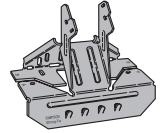

Variable Slope
Seat Connector

Depth	TJI®	Single Joist—Top Mount				Single Joist—Face Mount				Face Mount Skewed 45° Joist Hanger			
		Hanger	Fac. Res. (lbs)	Nailing		Hanger	Fac. Res. (lbs)	Nailing		Hanger	Fac. Res. (lbs)	Nailing	
				Header	Joist			Header	Joist			Header	Joist
18"	360	MIT3518	1,995	16d	10d x 1½"	MIU2.37/18	1,995	16d	10d x 1½"	SUR/L2.37/14	2,260	16d	10d x 1½"
	560	MIT418	2,305	16d	10d x 1½"	MIU3.56/18	2,305	16d	10d x 1½"	SUR/L414	2,360	16d	16d
20"	360	MIT3520	1,995	16d	10d x 1½"	MIU2.37/20	1,995	16d	10d x 1½"	SUR/L2.37/14	2,260	16d	10d x 1½"
	560	MIT420	2,305	16d	10d x 1½"	MIU3.56/20	2,305	16d	10d x 1½"	SUR/L414	2,360	16d	16d
22"	560D	HIT422	2,705	16d	10d x 1½"	MIU3.56/20	3,485	16d	10d x 1½"	SUR/L414⁽⁴⁾	2,895	16d	16d
24"	560D	HIT424	2,705	16d	10d x 1½"	MIU3.56/20	3,485	16d	10d x 1½"	SUR/L414⁽⁴⁾	2,895	16d	16d

Depth	TJI®	Double Joist—Top Mount				Double Joist—Face Mount			
		Hanger	Fac. Res. (lbs)	Nailing		Hanger	Fac. Res. (lbs)	Nailing	
				Header	Joist			Header	Joist
18"	360	BA4.75/18	4,370	16d	10d x 1½"	MIU4.75/18	3,485	16d	10d x 1½"
	560	HB7.12/18	5,450	16d	16d	HU414-2	4,615	16d	16d
20"	360	BA4.75/20	4,370	16d	10d x 1½"	MIU4.75/20	3,485	16d	10d x 1½"
	560	HB7.12/20	5,450	16d	16d	HU414-2	4,615	16d	16d
22"	560D	HB7.12/22	5,945	16d	16d	HU414-2	4,690	16d	16d
24"	560D	HB7.12/24	5,945	16d	16d	HU414-2⁽⁴⁾	4,690	16d	16d

Hanger information in this section was provided by Simpson Strong-Tie®. For additional information, please refer to their literature.

Depth	TJI®	Variable Slope Seat Joist Hanger ⁽²⁾				
		Hanger	Fac. Res. (lbs)		Nailing	
			Sloped Only	Sloped and Skewed	Header	Joist
18"-20"	360	LSSR2.37Z	1,560	1,200	10d	10d x 1½"
	560	LSSR410Z	2,045	1,835	16d	16d
22"-24"	560D	LSSR410Z	2,395	1,835	16d	16d

Depth	TJI®	Variable Slope Seat Connector ⁽¹⁾			
		Hanger	Fac. Res. (lbs)	Nailing	
				Header	Joist
18"-20"	360	VPA35	1,805	10d	10d x 1½"
	560	VPA4	1,855	10d	10d x 1½"
22"-24"	560D	VPA4	1,855	10d	10d x 1½"

General Notes

Italic hangers require web stiffeners.

Factored resistances will vary with different nailing criteria or other support conditions; contact your Weyerhaeuser representative for assistance.

- Hanger factored resistances shown are either joist bearing or hanger factored resistance—whichever is less. Joist end reaction must be checked to ensure it does not exceed the factored resistance shown in the tables.
- All factored resistances are for downward loads, standard term.
- Fill all round, dimple, and positive-angle nail holes.
- Use sloped seat hangers and beveled web stiffeners when TJI® joist slope exceeds ¼:12. **Maximum slope for 18"-24" TJI® joists is 3:12.**
- Leave ⅛" clearance (⅜" maximum) between the end of the supported joist and the header or hanger.
- Nails: 16d = 0.162" x 3½", 10d = 0.148" x 3", and 10d x 1½" = 0.148" x 1½".

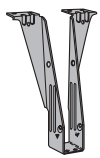

Single Joist, Top Mount

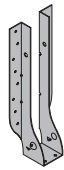

Single Joist, Face Mount

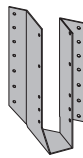

Face Mount Skewed 45° Joist Hanger

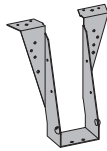

Double Joist, Top Mount

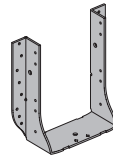

Double Joist, Face Mount

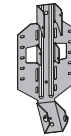

Variable Slope Seat Joist Hanger

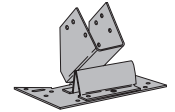

Variable Slope Seat Connector

Joist Depth	TJI®	Single Joist—Top Mount				Single Joist—Face Mount				Face Mount Skewed 45° Joist Hanger			
		Hanger	Fac. Res. (lbs)	Nailing		Hanger	Fac. Res. (lbs)	Nailing		Hanger	Fac. Res. (lbs)	Nailing	
				Header	Joist			Header	Joist			Header	Joist
18"	360	TFI3518	1,995	16d	10d x 1½"	IHF2318	1,995	10d	10d x 1½"	SKH2324L/R	1,755	10d	10d x 1½"
	560	TFI418	2,305	16d	10d x 1½"	IHF3518	2,305	10d	10d x 1½"	SKH414L/R ⁽³⁾	2,305	16d	16d
20"	360	TFI3520	1,995	16d	10d x 1½"	IHF2318	1,995	10d	10d x 1½"	SKH2324L/R ⁽⁴⁾	1,755	10d	10d x 1½"
	560	TFI420	2,305	16d	10d x 1½"	IHF3518	2,305	10d	10d x 1½"	SKH414L/R ⁽³⁾	2,305	16d	16d
22"	560D	TFI422	3,680	16d	10d x 1½"	IHF3518	3,310	10d	10d x 1½"	SKH414L/R ⁽³⁾⁽⁴⁾	3,680	16d	16d
24"	560D	TFI424	3,680	16d	10d x 1½"	IHF3518	3,310	10d	10d x 1½"	SKH414L/R ⁽³⁾⁽⁴⁾	3,680	16d	16d

(1) Miter cut is required at end of joists.

Joist Depth	TJI®	Double Joist—Top Mount				Double Joist—Face Mount			
		Hanger	Fac. Res. (lbs)	Nailing		Hanger	Fac. Res. (lbs)	Nailing	
				Header	Joist			Header	Joist
18"	360	THO23180-2	4,375	16d	10d	THF23160-2	3,990	10d	10d
	560	BPH7118	4,305	16d	10d	HD7160	4,615	16d	10d
20"	360	THO23200-2	4,375	16d	10d	THF23160-2	3,990	10d	10d
	560	BPH7120	4,305	16d	10d	HD7160	4,615	16d	10d
22"	560D	BPH7122	4,305	16d	10d	HD7160	4,710	16d	10d
24"	560D	BPH7124	4,305	16d	10d	HD7160	4,710	16d	10d

Hanger information in this section was provided by USP Structural Connectors®. For additional information, please refer to their literature.

Depth	TJI®	Variable Slope Seat Joist Hanger ⁽²⁾				
		Hanger	Fac. Res. (lbs)		Nailing	
			Sloped Only	Sloped and Skewed	Header	Joist
18"-20"	360	LSSH23	1,990	1,990	10d	10d x 1½"
	560	LSSH35	2,515	2,390	16d	10d x 1½"
22"-24"	560D	LSSH35	3,890	2,390	16d	10d x 1½"

Depth	TJI®	Variable Slope Seat Connector ⁽⁵⁾			
		Hanger	Fac. Res. (lbs)	Nailing	
				Header	Joist
18"-20"	360	TMP23	2,175	10d	10d x 1½"
	560	TMP4	2,175	10d	10d x 1½"
22"-24"	560D	TMP4	2,175	10d	10d x 1½"

Support Requirements

- Support material assumed to be Trus Joist® engineered lumber or sawn lumber (Douglas fir, southern pine, or spruce-pine-fir species).
- Minimum support width for single- and double-joist top mount hangers is 3".
- Minimum support width for face mount hangers with 10d and 16d nails (clinched) is 1½" and 1¾", respectively.

Also see General Notes on page 25.

Table footnotes for pages 25 and 26:

- (1) For joists 18" and deeper, use VPA for 3:12 slopes only.
- (2) For joists 18" and deeper, use only with slopes up to 3:12 and skews up to 45°. Additional lateral restraint required for 18" and 20" joists.
- (3) Miter cut required at end of joist.
- (4) Additional lateral restraint required.
- (5) For joist depths 18" and deeper, use only on slopes of 1:12 to 3:12.

This section contains framing details and design information applicable to all joist depths shown in this guide.

TJI® Joist Floor Framing

TJI® joist floor framing does not require bridging or mid-span blocking

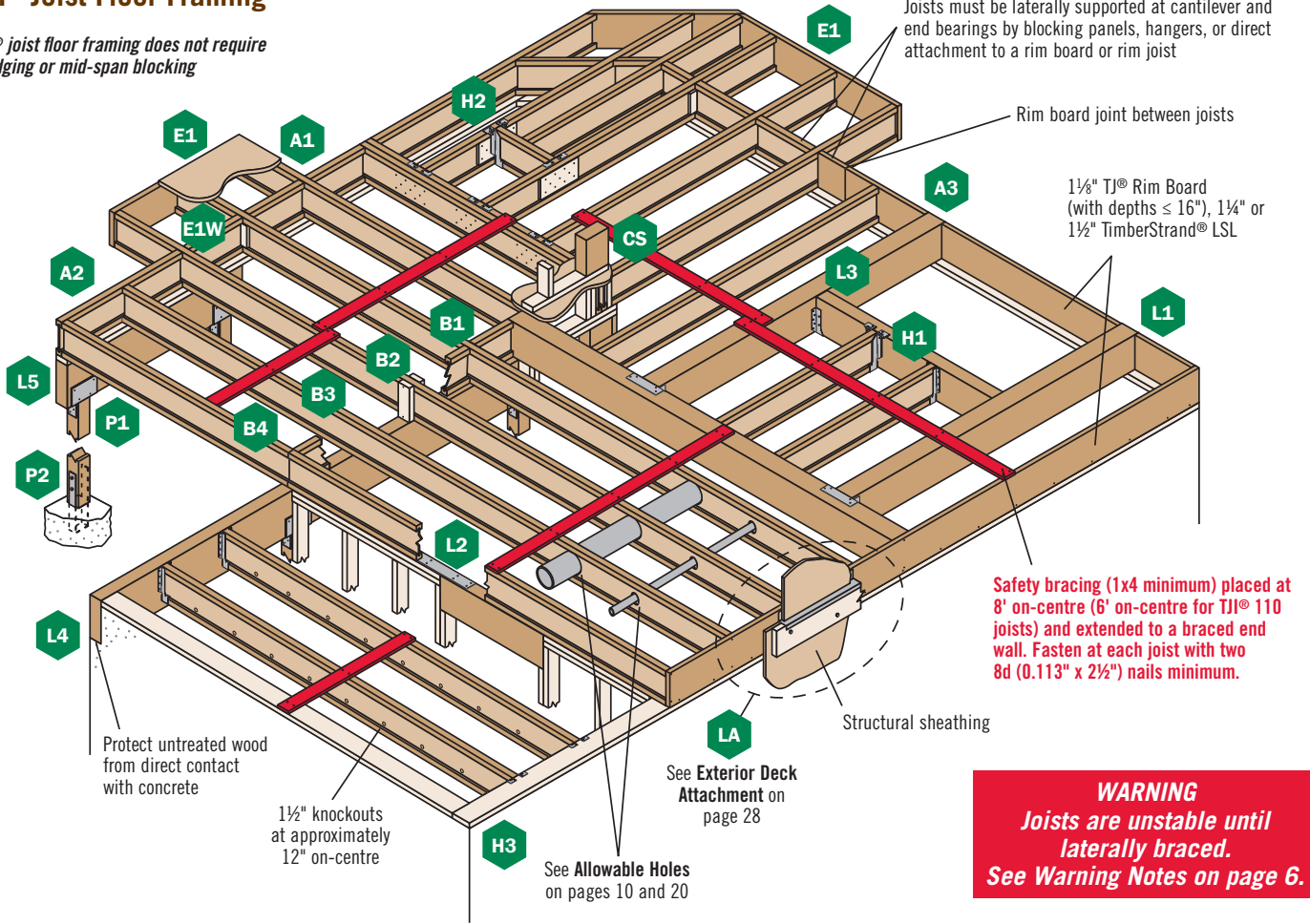

WARNING
Joists are unstable until laterally braced.
See Warning Notes on page 6.

TJI® Joist Nailing Requirements at Bearing

TJI® Joist to Bearing Plate

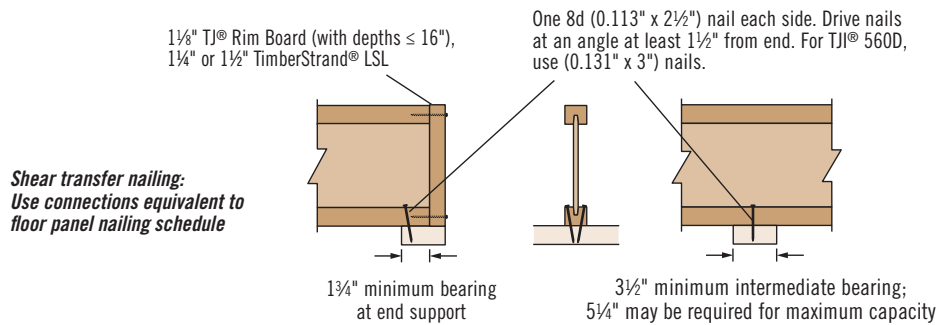

Squash Blocks to TJI® Joist (Load bearing wall above)

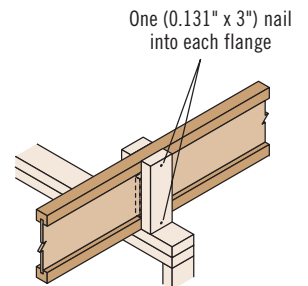

See page 29 for detail B2.

Rim to TJI® Joist

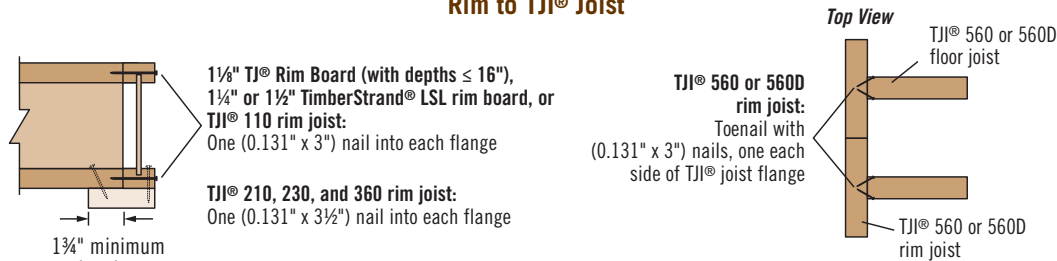

Locate rim board joint between joists

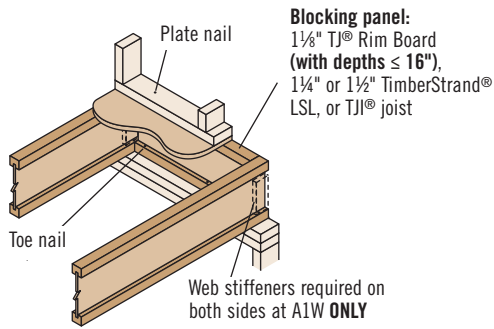

A1 **A1 W** Attach blocking per fastening instructions in Detail A3.

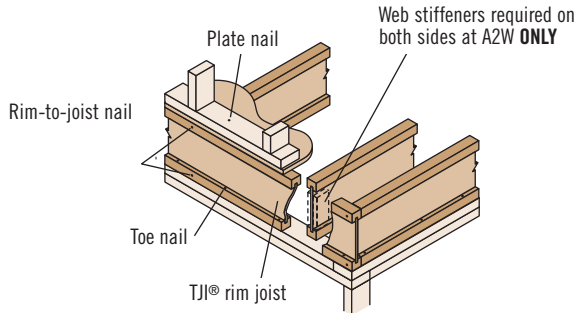

A2 **A2 W** Must have 1 1/4" minimum joist bearing at ends. Attach rim joist per fastening instructions in Detail A3.

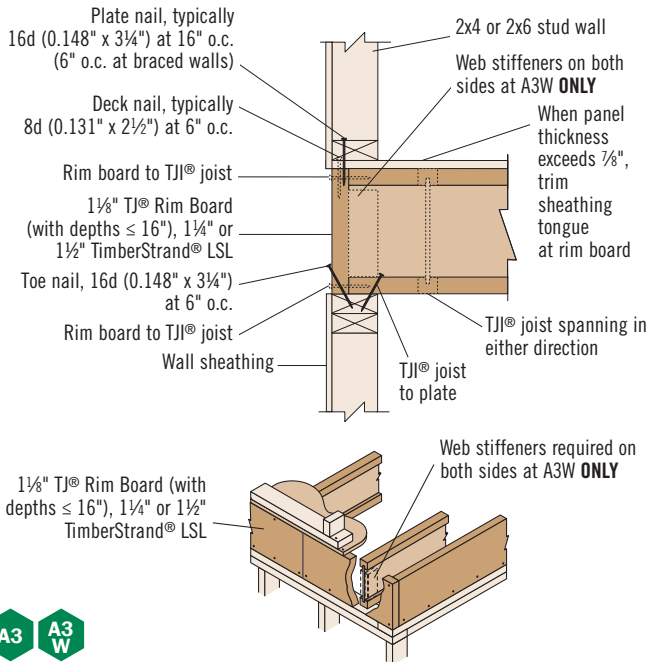

A3 **A3 W**

Exterior Deck Attachment

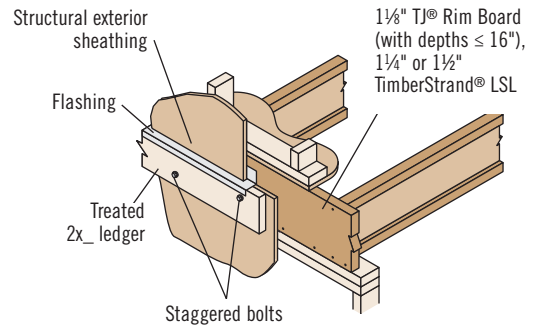

Shimmed Deck Attachment

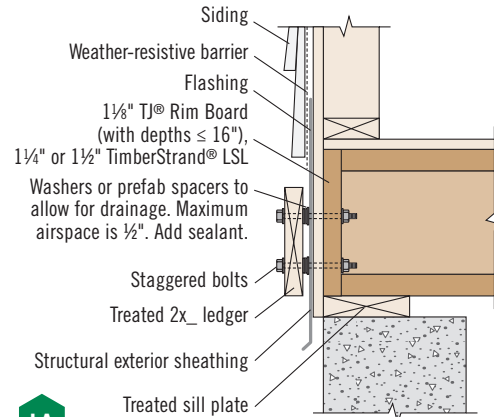

LA

Ledger Fastener⁽¹⁾ Factored Resistances

Rim Board Material	Factored Resistance Load ⁽²⁾ (lbs/bolt)		
	1/2" Lag Bolt	1/2" Through Bolt	1/2" Through Bolt with Air Space
1 1/8" TJ® Rim Board ⁽³⁾	695	1,010	890 ⁽⁴⁾
1 1/4" TimberStrand® LSL	885	1,050	
1 1/2" TimberStrand® LSL	980	1,050	

- (1) Corrosion-resistant fasteners required in wet-service applications.
- (2) Factored resistance determined in accordance with ASTM 7672.
- (3) 1 1/8" TJ® Rim Board is allowed with joist depths ≤ 16" only.
- (4) Maximum 1/2" shimmed air space.

General Notes

- Maintain 2" distance (minimum) from edge of ledger to fastener. Stagger bolts.
- Local building codes may require through bolts with washers.
- Lateral restraining connections may be required.
- See Weyerhaeuser's Rim Board Specifier's Guide, TJ-8500, for more information.

Vertical Load Transfer at Bearing

Rim or Blocking Material	Factored Vertical Load Resistance (PLF)								Factored Concentrated Load (lbs) All Depths	
	Depth									
	9 1/2"	11 7/8"	14"	16"	18"	20"	22"	24"		
TJJ® rim joist	3,060			2,250					2,475 ⁽¹⁾	—
1 1/8" TJ® Rim Board	7,045 ⁽²⁾								6,015	
1 1/4" TimberStrand® LSL	7,830 ⁽²⁾		7,250	6,290	5,365	4,580	3,930	5,450		
1 1/2" TimberStrand® LSL	9,395			9,250	8,325	7,350	6,440	6,555		

- (1) Capacity is based on calculation.
 - (2) Capacity is limited to a maximum of 522 psi in accordance with ASTM D7672.
 - (3) 1 1/8" TJ® Rim Board is limited to a depth of 16" or less.
- Values may not be increased for duration of load.

See page 27 for nailing requirements.

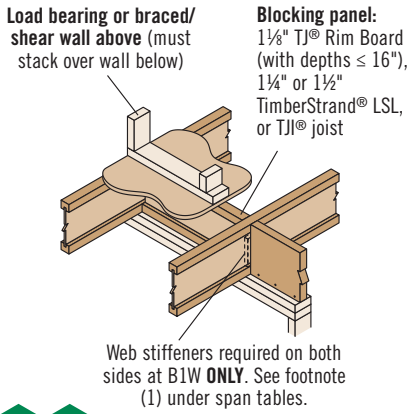

B1 B1 W

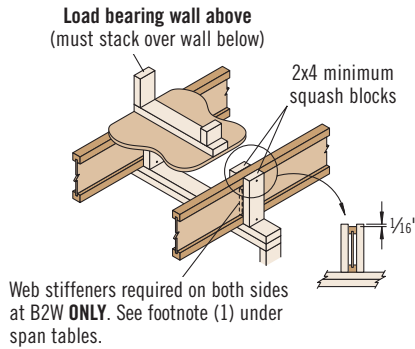

B2 B2 W

Blocking panels may be required with braced/shear walls above or below—see detail B1

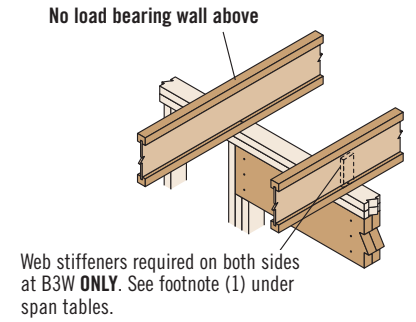

B3 B3 W

Blocking panels may be required with braced/shear walls above or below—see detail B1

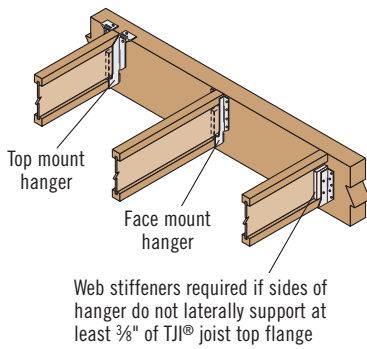

H1

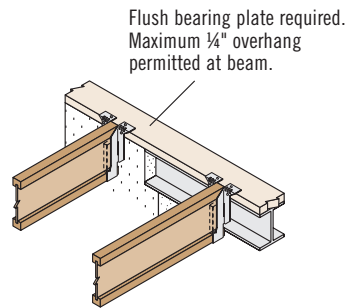

H3

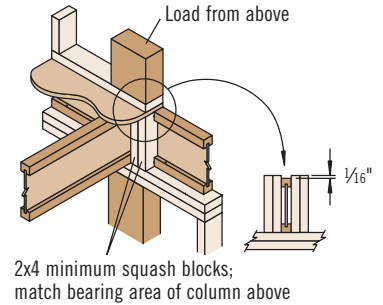

CS

Use 2x4 minimum squash blocks to transfer load around TJ® joist

Fastener Spacing for TJ® Joists

TJ®	Closest On-Centre Spacing per Row ⁽¹⁾		
	8d (0.113" x 2½"), 8d (0.131" x 2½"), 10d (0.128" x 3"), 12d (0.128" x 3¼")	10d (0.148" x 3"), 12d (0.148" x 3¼"), 16d (0.135" x 3½")	16d (0.162" x 3½")
110, 210, and 230	4"	4" ⁽²⁾	6"
360, 560 and 560D	3"	4" ⁽²⁾	6"

(1) Stagger nails when using 4" on-centre spacing or less and maintain ⅜" joist and panel edge distance. One row of fasteners is permitted (two at abutting panel edges) for diaphragms. For other applications, multiple rows of fasteners are permitted if the rows are offset at least ½" and staggered.

(2) Can be reduced to 3" on-centre for light gauge steel straps with 10d (0.148" x 1½") nails.

- Maximum spacing of nails is 18" on-centre for joists ≤ 16" deep; 24" on-centre for joists > 16" deep.
- 14 gauge staples may be substituted for 8d (0.113" x 2½") nails if minimum penetration of 1" is achieved.
- Table also applies to the attachment of TJ® rim joists and blocking panels to the wall plate.

Nails Installed on the Narrow Face

Nail Size	Closest On-Center Spacing per Row		
	1½" TJ® Rim Board ⁽¹⁾	TimberStrand® LSL	
		1¼"	1½"
8d (0.113" or 0.131" x 2½"), 10d (0.128" or 0.148" x 3"), 12d (0.128" x 3¼")	6"	4"	3"
12d (0.148" x 3¼")	12" ⁽²⁾	4"	3"
16d (0.162" x 3½")	16" ⁽³⁾	6" ⁽⁴⁾	6" ⁽⁴⁾
(0.131" x 3"-3½")	12" ⁽⁴⁾	4"	3"

- 1½" TJ Rim Board is allowed with joist depths ≤ 16" only.
- Can be reduced to 5" on-centre if nail penetration into the narrow edge is no more than 1¼" (to minimize splitting).
- Can be reduced to 8" on-centre if nail penetration into the narrow edge is no more than 1¼" (to minimize splitting).
- Can be reduced to 4" on-centre if nail penetration into the narrow edge is no more than 1¼" (to minimize splitting).
 - To minimize splitting, maintain edge distance and row spacing of 2½" nail diameter or ⅜", whichever is greater. Multiple rows must be staggered and equally spaced from the centreline of the narrow face axis.
 - 14 gauge staples may be substituted for 8d (0.113" x 2½") nails if minimum penetration of 1" is achieved.

See page 27 for nailing requirements.

Backer block: Install tight to top flange (tight to bottom flange with face mount hangers). Attach per table below.

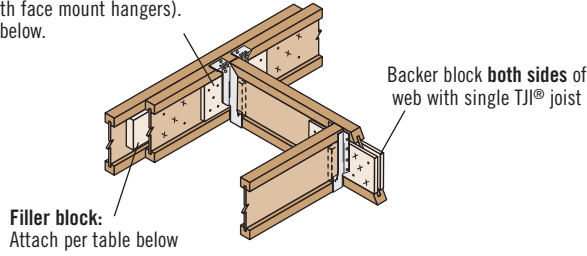

H2 With top mount hangers, backer block required only for factored downward loads exceeding 395 lbs or for uplift conditions

Filler and Backer Block Sizes

TJI®	110		210		230 or 360		360	560			560D
Depth	9½" or 11⅞"	14"	9½" or 11⅞"	14" or 16"	9½" or 11⅞"	14" or 16"	18" or 20"	9½" or 11⅞"	14" or 16"	18" or 20"	22" or 24"
Filler Block ⁽¹⁾ (Detail H2)	2x6	2x8	2x6 + ⅜" sheathing	2x8 + ⅜" sheathing	2x6 + ½" sheathing	2x8 + ½" sheathing	2x12 + ½" sheathing	Two 2x6	Two 2x8	Two 2x12	Four ¾" x 15" sheathing
Cantilever Filler (Detail E4)	2x6 4'-0" long	2x10 6'-0" long	2x6 + ⅜" sheathing, 4'-0" long	2x10 + ⅜" sheathing, 6'-0" long	2x6 + ½" sheathing, 4'-0" long	2x10 + ½" sheathing, 6'-0" long	Not applicable	Not applicable			
Backer Block ⁽¹⁾ (Detail F1 or H2)	⅝" or ¾"		¾" or ⅞"		⅞" or 1" net			2x6	2x8	2x12	Two ¾" x 15" sheathing
Nail Size	Filler	(0.131" x 3")						(0.131" x 3½")			
	Backer	(0.131" x 3")						(0.131" x 3")			
Nail Quantity ⁽²⁾	Filler ⁽³⁾	15						32			50
	Backer	15						15			15

- (1) If necessary, increase filler and backer block height for face mount hangers and maintain ⅛" gap at top of joist. See detail W. Filler and backer block dimensions should accommodate required nailing without splitting. The suggested minimum length is 24" for filler and 12" for backer blocks.
- (2) Clinch nails when possible.
- (3) For filler block connections, drive nails from alternating sides.

Web Stiffener Attachment

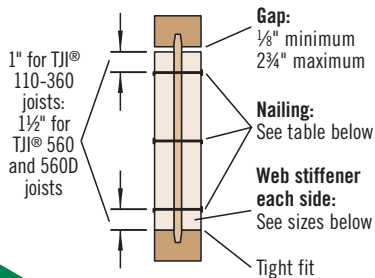

Web Stiffener Requirements

TJI®	Depth (in.)	Minimum Web Stiffener Size	Nail Type	Quantity	
				End	Int.
110	All	⅝" x 2 ⅝" ⁽¹⁾	8d (0.113" x 2½")	3	3
210	All	¾" x 2 ⅝" ⁽¹⁾		3	3
230, 360	All	⅞" x 2 ⅝" ⁽¹⁾		3	3
560	All	2x4 ⁽²⁾	16d (0.135" x 3½")	3	3
560D	22" ⁽³⁾	2x4 ⁽²⁾	16d (0.135" x 3½")	6	11
	24" ⁽³⁾			6	13

- (1) CSA standards 0151, 0325, or 0437 with face grain vertical.
- (2) Construction grade or better.
- (3) Web stiffeners are always required for 22" and 24" TJI® 560D joists.

See page 27 for nailing requirements.

WARNING
Joists are unstable until laterally braced. See Warning Notes on page 6.

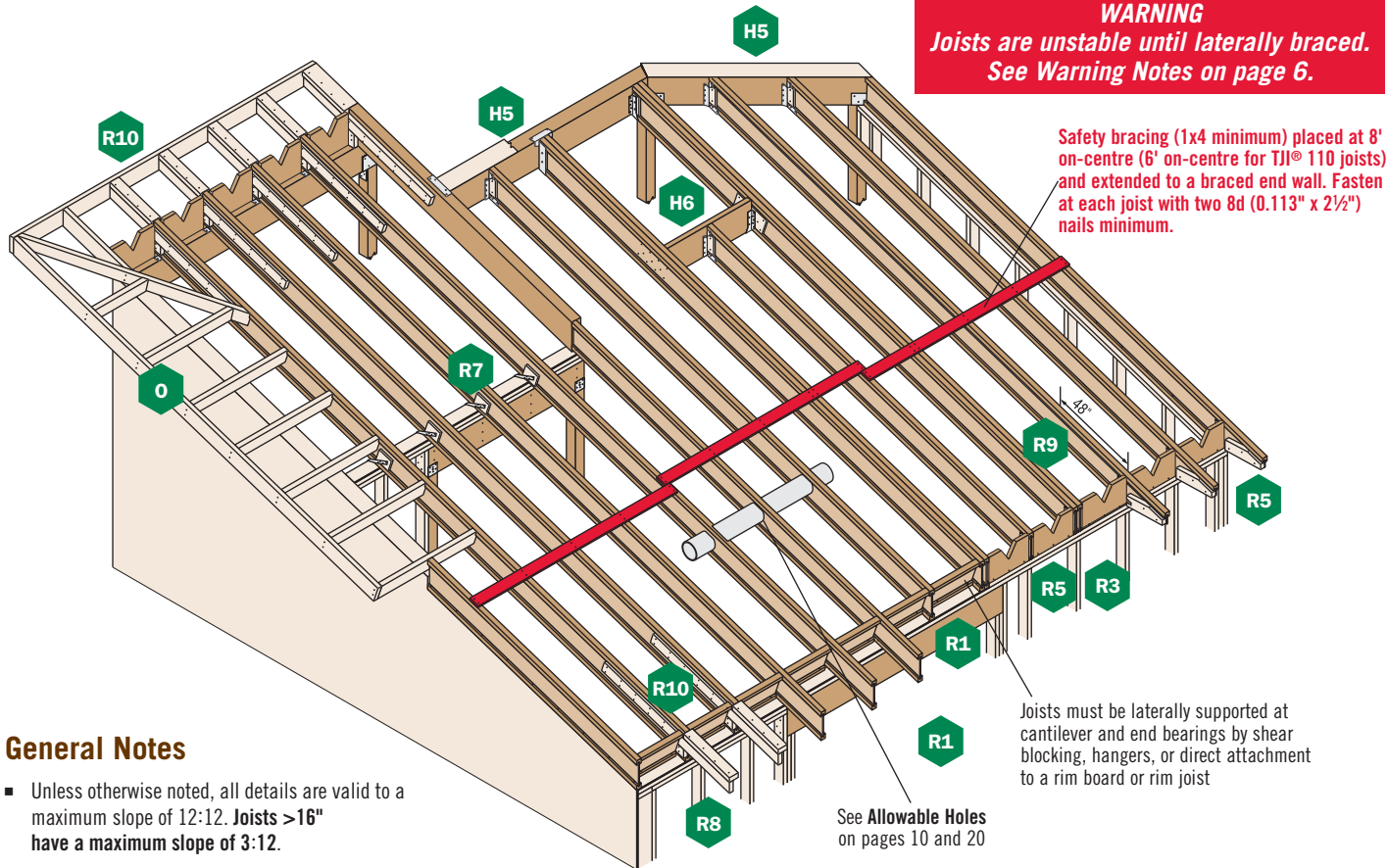

General Notes

- Unless otherwise noted, all details are valid to a maximum slope of 12:12. Joists >16" have a maximum slope of 3:12.
- Web stiffeners are required with all 22" and 24" joists and when the sides of the hanger do not laterally support at least ⅜" of the TJI® joist top flange. Also see framing plan.

TJI® Joist Nailing Requirements at Bearing (Maximum slope for 18"-24" joists is 3:12)

TJI® Joist to Bearing Plate

End Bearing
(1¼" minimum bearing required)

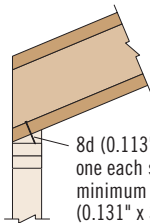

8d (0.113" x 2½") nail, one each side, 1½" minimum from end. Use (0.131" x 3") nails with TJI® 560D joists.

When slope exceeds ¼:12, a beveled bearing plate, variable slope seat connector, or birdsmouth cut (at low end of joist only) is required.

Intermediate Bearing
(3½" minimum bearing required)

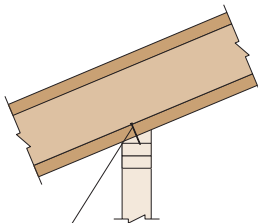

Slopes 3:12 or less:
One 8d (0.113" x 2½") nail each side. Use (0.131" x 3") nails with TJI® 560D joists. See detail R7.
Slopes greater than 3:12 (for depths ≤ 16" only):
Two 8d (0.113" x 2½") nails each side, plus a twist strap and backer block. See detail R7S.

When slope exceeds ¼:12 for a 2x4 wall or ⅛:12 for a 2x6 wall, a beveled bearing plate or variable slope seat connector is required.

Blocking to Bearing Plate

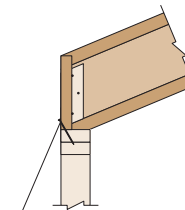

1½" TJI® Rim Board (with depths ≤ 16"), 1¼" or 1½" TimberStrand® LSL:
Toenail with (0.131" x 3") nails at 6" on-centre
TJI® joist blocking:
(0.131" x 3") nails at 6" on-centre
Shear transfer nailing:
Minimum, use connections equivalent to sheathing nail schedule

These Conditions Are NOT Permitted:



DO NOT cut holes too close to support.
Refer to Allowable Holes on pages 10 and 20 for minimum distance from support.

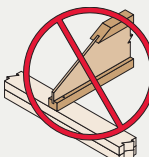

DO NOT bevel cut joist beyond inside face of wall.

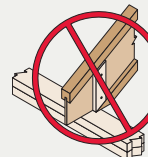

DO NOT overhang birdsmouth cut from inside face of plate.
TJI® joist flange must bear fully on the plate. See detail BC on page 33.

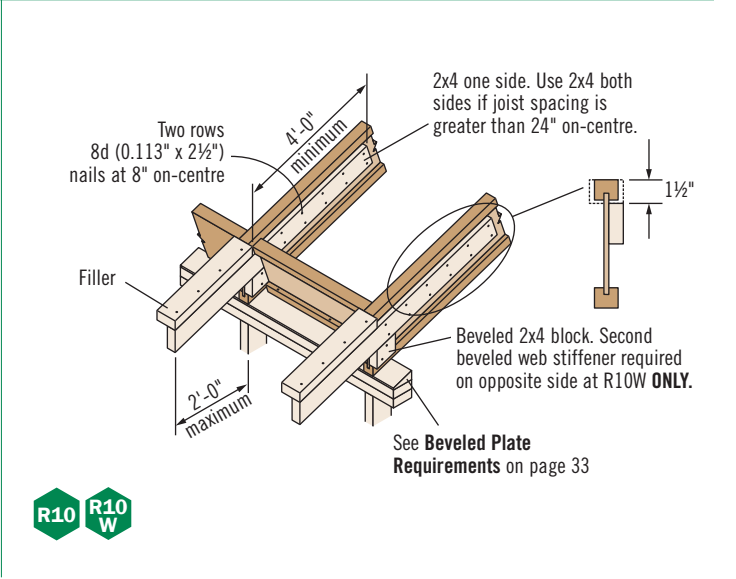
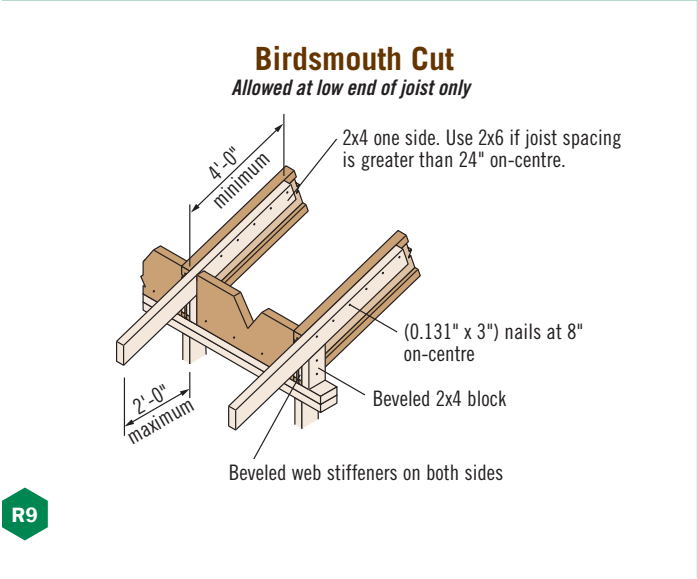
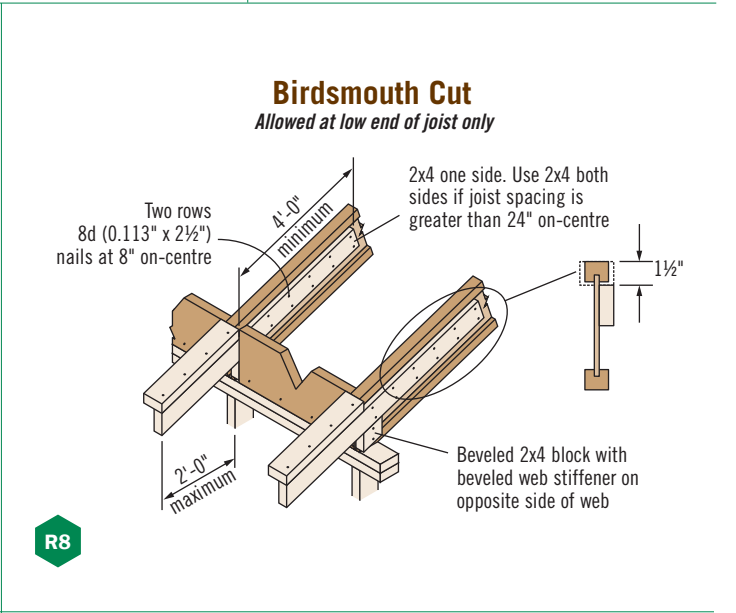
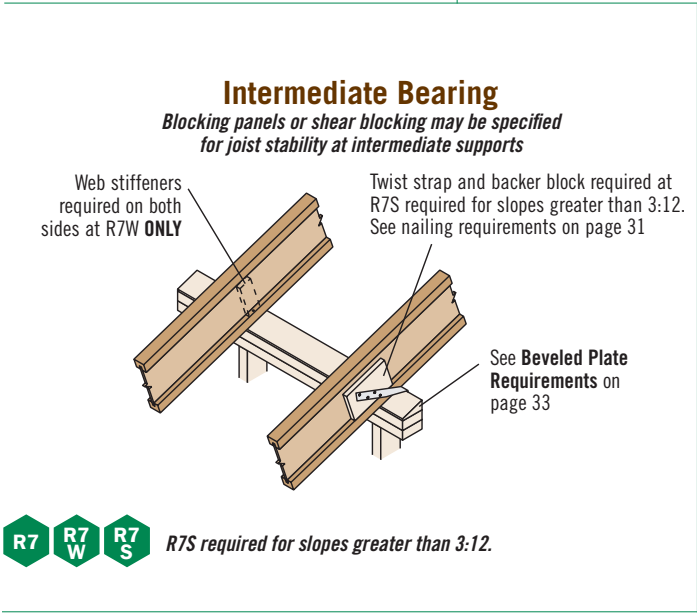
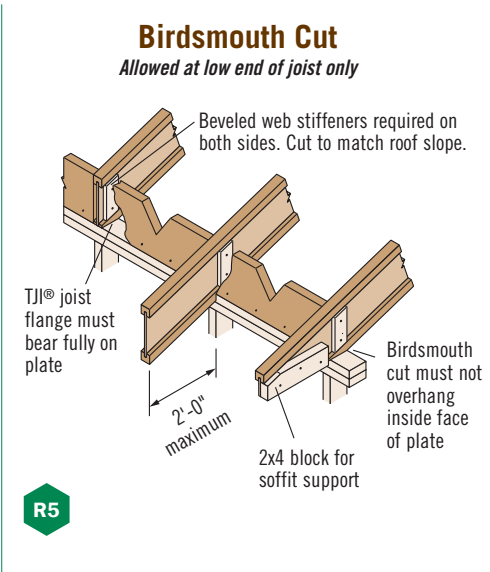
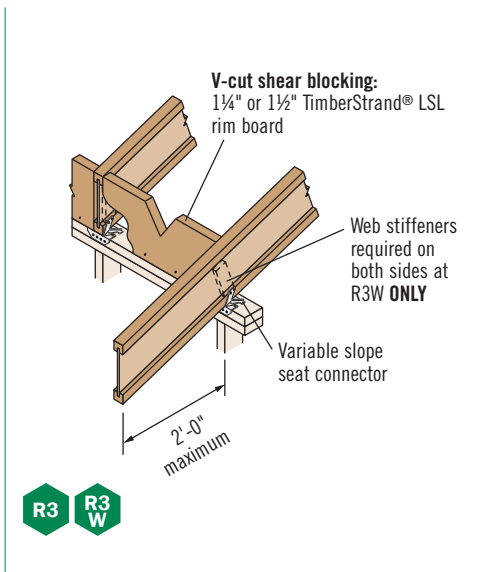
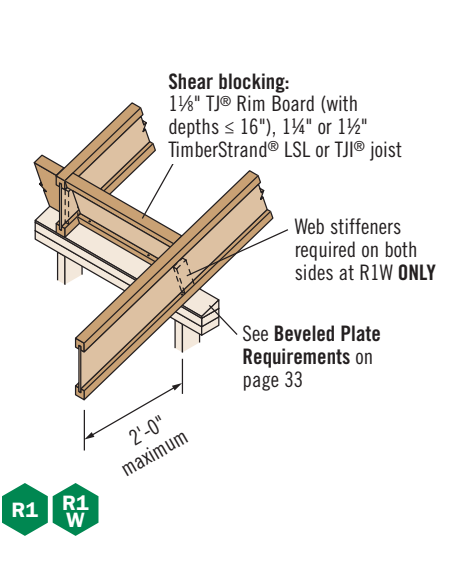

See page 31 for General Notes and nailing requirements.

Shear Blocking and Ventilation Holes (Roof Only)

Field trim to match joist depth at outer edge of wall or locate on wall to match joist depth

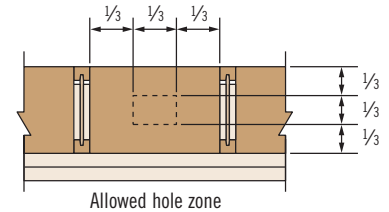
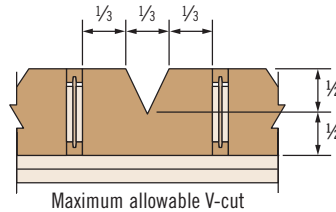
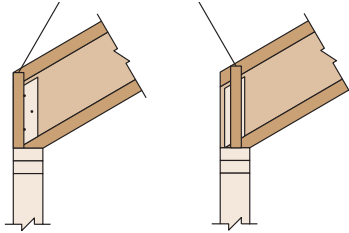

SB

For TJI® joists with slopes of 10:12 to 12:12, the vertical depth of the shear blocking at bearing will require 1 1/8" TJI® Rim Board, 1 1/4" or 1 1/2" TimberStrand® LSL that is one size deeper than the TJI® joist. DO NOT use 1 1/8" TJI® Rim Board with 18"-24" TJI® joists or in ventilation-hole applications.

LSTA18 (Simpson or USP) strap with twelve 10d (0.148" x 1 1/2") nails

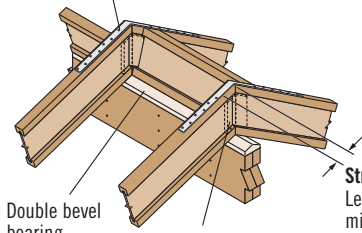

Double bevel bearing plate. See Beveled Plate Requirements below

Web stiffeners required on both sides at R14W ONLY

Strap nails: Leave 2 3/8" minimum end distance

R14 **R14W**

Additional blocking may be required for shear transfer

O

Nail through web into outrigger

Double joist may be required when L exceeds joist spacing

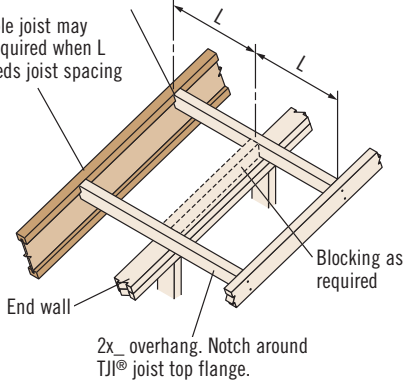

Birdsmouth Cut

Allowed at low end of joist only

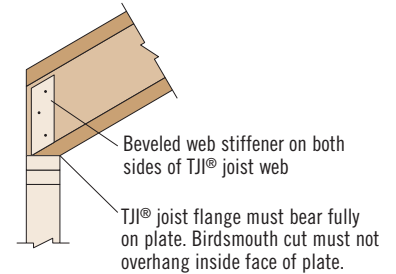

BC

LSTA24 (Simpson or USP) strap with twelve 10d (0.148" x 1 1/2") nails required at H5S

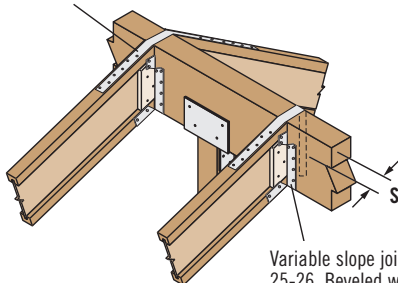

Additional blocking may be required for shear transfer

Strap nails: Leave 2 3/8" minimum end distance

Variable slope joist hanger. See pages 16-17 and 25-26. Beveled web stiffener required both sides.

H5 **H5S**

Detail H5S is required for slopes greater than 3:12.

Beveled Plate Requirements

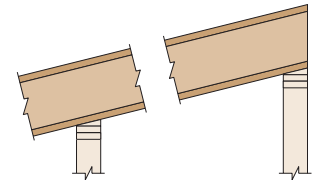

Required Bearing Length	Maximum Slope Without Beveled Plate
1 3/4"	1/2:12
3 1/2"	1/4:12
5 1/2"	1/8:12

See page 31 for General Notes and nailing requirements.

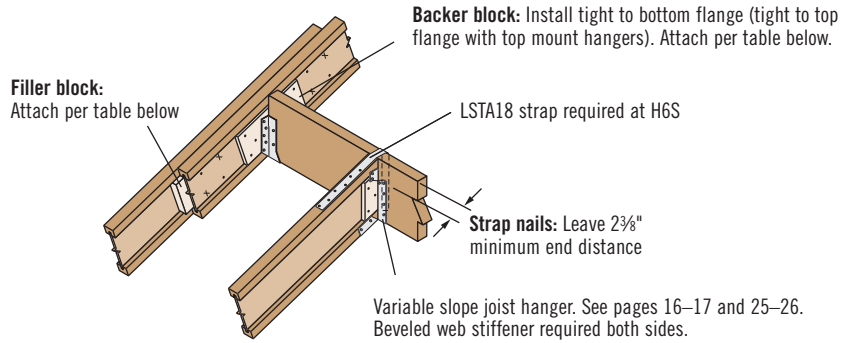

H6 H6S Detail H6S is required for slopes greater than 3:12.

Filler and Backer Block Sizes

TJI®	110		210		230 or 360		360	560			560D
Depth	9 1/2" or 11 1/8"	14"	9 1/2" or 11 1/8"	14" or 16"	9 1/2" or 11 1/8"	14" or 16"	18" or 20"	9 1/2" or 11 1/8"	14" or 16"	18" or 20"	22" or 24"
Filler Block⁽¹⁾ (Detail H2)	2x6	2x8	2x6 + 3/8" sheathing	2x8 + 3/8" sheathing	2x6 + 1/2" sheathing	2x8 + 1/2" sheathing	2x12 + 1/2" sheathing	Two 2x6	Two 2x8	Two 2x12	Four 3/4" x 15" sheathing
Cantilever Filler (Detail E4)	2x6 4'-0" long	2x10 6'-0" long	2x6 + 3/8" sheathing, 4'-0" long	2x10 + 3/8" sheathing, 6'-0" long	2x6 + 1/2" sheathing, 4'-0" long	2x10 + 1/2" sheathing, 6'-0" long	Not applicable	Not applicable			
Backer Block⁽¹⁾ (Detail F1 or H2)	5/8" or 3/4"		3/4" or 7/8"		7/8" or 1" net			2x6	2x8	2x12	Two 3/4" x 15" sheathing
Nail Size	Filler	(0.131" x 3")						(0.131" x 3 1/2")			
	Backer	(0.131" x 3")						(0.131" x 3")			
Nail Quantity⁽²⁾	Filler⁽³⁾	15						32			50
	Backer	15						15			15

(1) If necessary, increase filler and backer block height for face mount hangers and maintain 1/8" gap at top of joist. See detail W. Filler and backer block dimensions should accommodate required nailing without splitting. The suggested minimum length is 24" for filler and 12" for backer blocks.

(2) Clinch nails when possible.

(3) For filler block connections, drive nails from alternating sides.

See page 31 for General Notes and nailing requirements.

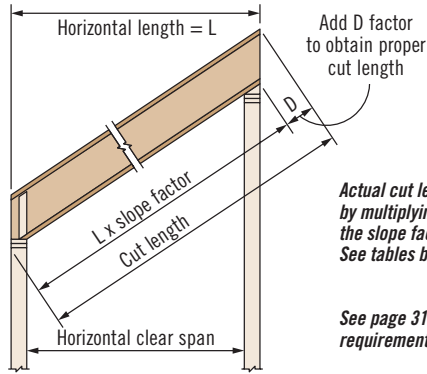

Actual cut length can be approximated by multiplying the horizontal length by the slope factor and adding the D factor. See tables below.

See page 31 for General Notes and nailing requirements.

D Factors

Depth	Slope															
	1:12	1½:12	2:12	2½:12	3:12	3½:12	4:12	4½:12	5:12	6:12	7:12	8:12	9:12	10:12	11:12	12:12
9½"	7⁄8"	1¼"	1½"	2"	2½"	2¾"	3¼"	3½"	4"	4¾"	5½"	6¾"	7½"	8"	8¾"	9½"
11⅞"	1"	1½"	2"	2½"	3"	3½"	4"	4½"	5"	6"	7"	8"	9"	10"	11"	11⅞"
14"	1¼"	1¾"	2¾"	3"	3½"	4½"	4¾"	5¼"	5⅞"	7"	8¼"	9¾"	10½"	11¾"	12⅞"	14"
16"	1¾"	2"	2¾"	3¾"	4"	4¾"	5¾"	6"	6¾"	8"	9¾"	10¾"	12"	13¾"	14¾"	16"
18"	1½"	2¼"	3"	3¾"	4½"											
20"	1⅝"	2½"	3⅝"	4½"	5"											
22"	1⅞"	2¾"	3⅞"	4⅞"	5½"											
24"	2"	3"	4"	5"	6"											

Slope Factors

Slope	2½:12	3:12	3½:12	4:12	4½:12	5:12	6:12	7:12	8:12	9:12	10:12	11:12	12:12
Factor	1.021	1.031	1.042	1.054	1.068	1.083	1.118	1.158	1.202	1.250	1.302	1.357	1.414

MATERIAL WEIGHTS AND CONVERSION TABLES

Material Weights

(Include TJI® weights in dead load calculations—see Design Properties tables on pages 6 and 18 for joist weights)

Floor Panels

Southern Pine

½" plywood	1.7 psf
⅝" plywood	2.0 psf
¾" plywood	2.5 psf
1⅛" plywood	3.8 psf
½" OSB	1.8 psf
⅝" OSB	2.2 psf
¾" OSB	2.7 psf
⅞" OSB	3.1 psf
1⅛" OSB	4.1 psf

Based on: Southern pine – 40 pcf for plywood, 44 pcf for OSB

Roofing

Asphalt shingles	2.5 psf
Wood shingles	2.0 psf
Clay tile	9.0 to 14.0 psf
Slate (¾" thick)	15.0 psf

Roll or Batt Insulation (1" thick):

Rock wool	0.2 psf
Glass wool	0.1 psf

Floor Finishes

Hardwood (nominal 1")	4.0 psf
Sheet vinyl	0.5 psf
Carpet and pad	1.0 psf
¾" ceramic or quarry tile	10.0 psf

Concrete:

Regular (1")	12.0 psf
Lightweight (1")	8.0 to 10.0 psf
Gypsum concrete (¾")	6.5 psf

Ceilings

Acoustical fibre tile	1.0 psf
½" gypsum board	2.2 psf
⅝" gypsum board	2.8 psf
Plaster (1" thick)	8.0 psf

PSF to PLF

O.C. Spacing	Load in Pounds Per Square Foot (PSF)								
	20	25	30	35	40	45	50	55	60
12"	20	25	30	35	40	45	50	55	60
16"	27	34	40	47	54	60	67	74	80
19.2"	32	40	48	56	64	72	80	88	96
24"	40	50	60	70	80	90	100	110	120

Metric to Imperial

Metric Unit	Imperial Conversion
1 kN	0.2248 kip
1 N	0.2248 lb
1 m	3.281 ft
1 mm	0.0394 in.
1 kg	2.205 lb mass
1 N • m	0.7376 lb • ft
1 N • m	8.851 lb • in.
1 mm ⁴	2.402 x 10 ⁻⁶ in. ⁴
1 Pa	0.0209 lb/ft ²
1 kPa	0.1450 lb/in. ²

Imperial to Metric

Imperial Unit	Metric Conversion
1 kip	4.448 kN
1 lb	4.448 N
1 ft	0.3048 m
1 in.	25.40 mm
1 lb mass	0.4536 kg
1 lb • ft	1.356 N • m
1 lb • in.	0.1130 N • m
1 in. ⁴	0.4162 x 10 ⁶ mm ⁴
1 lb/ft ²	47.88 Pa
1 lb/in. ²	6.895 kPa

WE CAN HELP YOU BUILD SMARTER

You want to build solid and durable structures—we want to help. Weyerhaeuser provides high-quality building products and unparalleled technical and field assistance to support you and your project from start to finish.

Floors and Roofs: Start with the best framing components in the industry: our Trus Joist® TJI® joists; TimberStrand® LSL rim board; and TimberStrand® LSL, Microllam® LVL, and Parallam® PSL headers and beams. Pull them all together with our self-gapping and self-draining Weyerhaeuser Edge Gold™ floor panels and durable Weyerhaeuser roof sheathing.

Walls: Get the best value out of your framing package—use TimberStrand® LSL studs for tall walls, kitchens, and bathrooms, and our traditional, solid-sawn lumber everywhere else. Cut down installation time by using TimberStrand® LSL headers for doors and windows, and Weyerhaeuser wall sheathing with its handy two-way nail lines.

Software Solutions: Whether you are a design professional or lumber dealer, Weyerhaeuser offers an array of software packages to help you specify individual framing members, create cut lists, manage inventories—even help you design a complete structural frame. Contact your Weyerhaeuser representative to find out how to get the software you need.

Technical Support: Need technical help? Weyerhaeuser has one of the largest networks of engineers and sales representatives in the business. Call us for help, and a skilled member from our team of experts will answer your questions and work with you to develop solutions that meet all your structural framing needs.

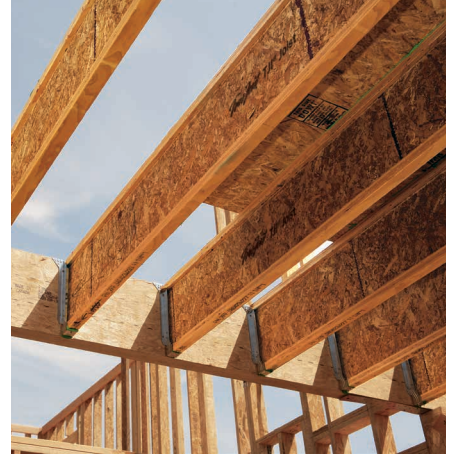

LIMITED LIFETIME PRODUCT WARRANTY

Weyerhaeuser provides limited lifetime warranties for all Trus Joist® branded products. Product information, installation instructions, and the full text of each product's limited warranty (including limitations and exclusions) are available on the Weyerhaeuser website, from your Weyerhaeuser representative, or by calling toll free: 888-453-8358.

Additionally, Weyerhaeuser offers limited warranties on a broad variety of its other products. To see complete details of all Weyerhaeuser product warranties, visit weyerhaeuser.com/woodproducts/warranty.

1.888.453.8358
WEYERHAEUSER.COM/WOODPRODUCTS

Form 10 2024 December 2024. A Weyerhaeuser and Trus Joist are registered trademarks of Weyerhaeuser NR. © 2024 Weyerhaeuser NR Company. All rights reserved. Additional restrictions, limitations and exclusions apply to certain products. Please visit weyerhaeuser.com/warranty.

CONTACT US

1.888.453.8358 • weyerhaeuser.com/woodproducts/contact

Contact your local representative or dealer at:

Visit weyerhaeuser.com/woodproducts/warranty for copies of this and other Trus Joist® Engineered Wood Product warranties.

March 2024 • Reorder TJ-4500

This document supersedes all previous versions. If this is more than one year old, contact your dealer or Weyerhaeuser rep.

 Weyerhaeuser, Forte, Javelin, Microllam, Parallam, TimberStrand, TJ, TJI, and Trus Joist are registered trademarks and Edge Gold and TJ-Pro are trademarks of Weyerhaeuser NR. © 2024 Weyerhaeuser NR Company. All rights reserved. Printed in the USA.