



WALL GUIDE: CALIFORNIA, NEVADA, ARIZONA



Featuring Trus Joist® TimberStrand® LSL
and Parallam® PSL Wall Framing

- Engineered to meet code requirements for walls up to 30' tall
- Easy-to-use tables adaptable to a variety of wind conditions, surface finishes, and wall layouts
- Out-of-plane wind and vertical load information for designing walls that are stiff, strong, and straight
- Limited product warranty





The products in this guide are readily available through our nationwide network of distributors and dealers. For more information on other applications or other Trus Joist® products, contact your Weyerhaeuser representative.

Code Evaluations:
See ICC-ES ESR-1387

TABLE OF CONTENTS

Deflection Requirements	2
Conventional Construction Applications	3
Definitions	4
Engineered Design Assumptions	4
Wind Tables	5
Design Example	5
Stud Load Table	6-7
Stud Example	7
One-Hour Wall Assembly	7
Column Load Table	8-9
Column Example	9
Header Load Table	10
Header Example	11
Multiple-Member Connections	11
Typical Tall Wall Framing	12
Wall Details	13
Framing Connectors	13
Allowable Holes	14
Design Properties	15



Choose Trus Joist® wall framing for straight, flush walls that:

- are critical for tile applications.
- allow easy countertop and cabinet installation in kitchens and bathrooms.
- give visual appeal to tall walls in great rooms and entryways.
- have the strength and stiffness to accommodate “window” walls.

Many of today’s homes have design requirements—such as walls over 10 feet tall—that exceed the code provisions for conventional construction. Trus Joist® TimberStrand® laminated strand lumber (LSL) and Parallam® parallel strand lumber (PSL) can help you meet the requirements of these challenging designs. Weyerhaeuser also offers product and design support that includes technical information, design software, and design advice from our team of skilled engineers and sales representatives.

Tall Wall Software Solutions

ForteWEB™ software is a single-member sizing solution created by Weyerhaeuser to help estimators, architects, and engineers design walls quickly and efficiently. ForteWEB™ software provides the most economical solutions for studs, columns, and headers, and helps you design connections for each member. Professional calculations can be printed out for engineer sign-off or to give to building officials. Ask your Weyerhaeuser representative how you can get ForteWEB™ software today.

This guide features the following Trus Joist® wall framing products:

1.3E TimberStrand® LSL

Columns: 3½" x 3½" • 3½" x 5½"
3½" x 7¼"

Headers: 3½" x 5½" • 3½" x 7¼"

1.55E TimberStrand® LSL

Headers: 3½" x 9½" • 3½" x 11⅞"

1.6E TimberStrand® LSL

Studs and Columns: 1½" x 3½" (2x4)
1½" x 5½" (2x6)
1½" x 7¼" (2x8)

1.8E Parallam® PSL

Columns: 3½" x 3½" • 3½" x 5½"
3½" x 7" • 5¼" x 5¼"
5¼" x 7" • 7" x 7"

Headers: 5¼" x 5¼"

2.0E Parallam® PSL

Columns: 3½" x 9½" • 5¼" x 9½"
7" x 9½"

Headers: 5¼" x 9½"

Other sizes may be available in Weyerhaeuser software; however, not all products are available in all markets. Contact your Weyerhaeuser representative for the sizes available in your area.



WARNING: This product can expose you to chemicals including wood dust which are known to the State of California to cause cancer, and methanol, which are known to the State of California to cause birth defects or other reproductive harm. Drilling, sawing, sanding or machining wood products can expose you to wood dust. Avoid inhaling wood dust or use a dust mask or other safeguards for personal protection. For more information go to www.P65Warnings.ca.gov and www.P65Warnings.ca.gov/wood.

Safety data sheets for all Weyerhaeuser wood products can be found on our website at: weyerhaeuser.com/sustainability/environment/product-stewardship/safety-data-sheets.

DEFLECTION REQUIREMENTS

How stiff does a wall need to be?

While model building codes provide required deflection limits based on the type of finish supported by the wall framing, acceptable deflection limits are usually established by the design professional, finish-material provider, and/or building code authority. Typical deflection requirements are shown in the table at right.

Code Minimum Deflection Criteria

Type of Wall	Maximum Deflection
Exterior walls with plaster or stucco finish ⁽¹⁾	L/360 ⁽⁵⁾
Exterior walls with brittle finishes ⁽¹⁾⁽²⁾	L/240
Exterior walls with flexible finishes ⁽¹⁾⁽²⁾	L/120
Exterior walls with interior gypsum board finish ⁽³⁾	L/180
Members supporting windows (mullions) ⁽⁴⁾	L/175

(1) 2015/2018/2021/2024 International Residential Code (IRC) Table R301.7

(2) 2015/2018/2021/2024 International Building Code (IBC) Table 1604.3

(3) 2015/2018/2021/2024 IRC Table R301.7, footnote d

(4) 2015/2018/2021/2024 IRC Section R609.8.2 and 2015/2018/2021/2024 IBC Section 2403.3

(5) For finishes that require a deflection stricter than L/360, contact your Weyerhaeuser representative.

CONVENTIONAL CONSTRUCTION APPLICATIONS

Limitations of Conventional Construction

For walls up to 10' in height, 2x4 and 2x6 1.3E TimberStrand® LSL studs may be conventionally specified per the limitations described in this section. Engineered design for more demanding applications is outlined on the pages that follow.

Wind Limitations

Basic wind speed (2015 IRC):
Figure R301.2(4)B

Basic wind speed (2018 IRC):
Figure R301.2(5)B

Basic wind speed (2021/2024 IRC):
Figure R301.2.1.1

Seismic Design Categories

A, B, C, D₀, D₁, and D₂. Excludes irregular portions of structures as defined by 2015 IRC Section R301.2.2.2.5 and 2018/2021/2024 IRC Section R301.2.2.6

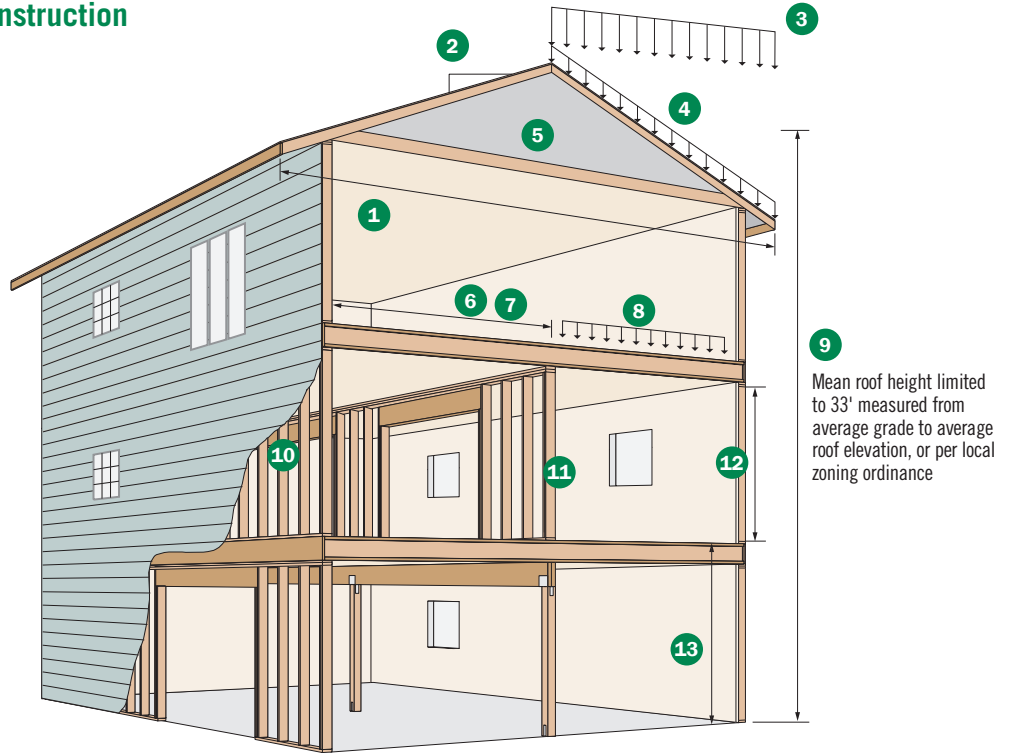

Limitation Descriptions and IRC References

Description	IRC Reference
1 Maximum roof span, including overhangs, limited to 40'. Maximum tabulated rafter span (horizontal projection) and ceiling joist span of 26'.	IRC Section R802.10.2.1; footnote <i>a</i> to 2015 IRC Tables R802.4(1), R802.4(2) and 2018/2021/2024 IRC Tables R802.5.1(1), R802.5.1(2); footnote <i>b</i> to 2015 IRC Tables R802.5.1(1)–R802.5.1(8) and 2018/2021/2024 IRC Tables R802.4.1(1)–R802.4.1(8)
2 Roof pitch: 3:12 minimum, 12:12 maximum	
3 Maximum ground snow load: 70 psf	IRC Section R301.2.3
4 Maximum tabulated roof/ceiling dead load: 20 psf	2015 IRC Tables R802.5.1(1)–R802.5.1(8) and 2018/2021/2024 Tables 2.4.1(1)–R802.4.1(8)
5 Maximum tabulated rafter and ceiling joist spacing: 24" on-center	2015 IRC Tables R802.4(1), R802.4(2), R802.5.1(1)–R802.5.1(8) and 2018/2021/2024 IRC Tables R802.4.1(1)–R802.4.1(8), R802.5.1(1), R802.5.1(2)
6 Maximum tabulated joist span: 26'	IRC Tables R502.3.1(1), R502.3.1(2)
7 Maximum tabulated floor joist spacing: 24" on-center	IRC Tables R502.3.1(1), R502.3.1(2)
8 Maximum uniform floor loads: 40 psf live load, 20 psf dead load	IRC Tables R502.3.1(1), R502.3.1(2)
9 Maximum of 3 stories	IRC Section R101.2
10 Maximum stud spacing: 24" on-center	IRC Table R602.3(5)
11 With TJI® joist floor systems, load-bearing walls must stack directly over bearing walls or beams below. With rectangular joists, walls may be offset a distance equal to the joist depth.	IRC Section R502.4
12 Maximum load-bearing stud length: 10' between points of lateral support	IRC Table R602.3(5)
13 Maximum story height: 10' stud height plus 16" floor framing = 11'-4"	IRC Section R301.3

Stud Specifications for Conventional Applications per IRC Table R602.3(5)

Stud Size	Bearing Walls				Nonbearing Walls		
	Laterally unsupported stud height ⁽¹⁾	Maximum spacing when supporting roof and ceiling only	Maximum spacing when supporting one floor, roof, and ceiling	Maximum spacing when supporting two floors, roof, and ceiling	Maximum spacing when supporting one floor only	Laterally unsupported stud height ⁽¹⁾	Maximum spacing
2x4	10'	24"	16"	–	24"	14'	24"
2x6	10'	24"	24"	16"	24"	20'	24"

(1) Listed heights are distances between points of lateral support placed perpendicular to the plane of the wall.

Allowable Holes and Notches for TimberStrand® LSL Studs

Holes may be drilled anywhere along the length of the stud, but must be at least 5/8" from the edge

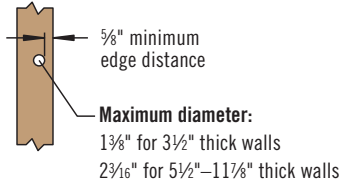

For 2x4 and 2x6 studs, one notch may be cut anywhere along the length of the stud. For larger studs, the notch may be cut anywhere except the middle 1/3 of the length of the stud.

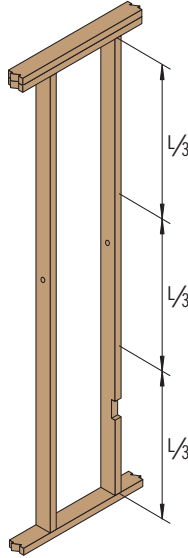
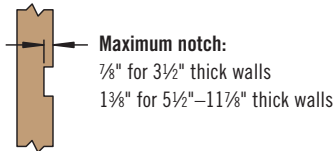

When used in conventional construction applications, both 2x4 and 2x6 TimberStrand® LSL studs may be drilled or notched in accordance with IRC section R602.6.

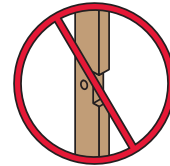

DO NOT cut a notch and a hole in the same cross section

DEFINITIONS

Buckling Length—Distance along the length of a member between braced points. This length is used to calculate the buckling stability of the member.

Conventional Construction—Generally, home design based on traditional construction methods and materials that have a history of adequate structural performance for specific building types and sizes. Both conventionally specified and pre-calculated members and connections are prescriptively specified in building codes such as the IRC and IBC, and may be combined to form a structure or structural assemblage.

Components and Cladding (C&C)—Elements of the building envelope or elements of building appurtenances and rooftop structures and equipment that do not qualify as part of the MWFRS.

Design Wind Pressure—The equivalent static wind pressure applied to structures to determine wind loads for buildings.

Effective Wind Area—The area used to determine the external pressure coefficient to be used in the determination of wind loads for buildings. For C&C elements, the

effective wind area is the span length multiplied by the tributary width or $L^2/3$, whichever is greater.

Lateral Loads—Loads applied to a structure in the horizontal direction. This includes loads from wind and seismic events.

Main Wind Force Resisting System (MWFRS)—An assemblage of structural elements assigned to provide support and stability for the overall building or other structure. The system generally receives wind loading from more than one surface.

Tributary Area—A calculated area of influence surrounding a structural member. Loads within this area are added together to determine the amount of load a member is required to resist. For example, the tributary area for a wall stud is the sum of 1/2 the distance to the adjacent wall stud on each side of the stud in question. Likewise, the tributary area for a floor joist would be the sum of 1/2 the distance to the adjacent joist on each side of the joist in question.

ENGINEERED DESIGN ASSUMPTIONS

Design applications are limited to vertical loads, and to lateral wind loads that are perpendicular to the wall framing. Table information is based on the strength calculations and deflection limits of wall framing members, and was generated with the following assumptions:

- Member design is based on the *National Design Specification® (NDS®) for Wood Construction*.
- Stud and column tables assume structural sheathing on one side of the wall, or a combination of gypsum wallboard and non-structural sheathing or siding applied to each side of the wall, or equivalent.
- Column lateral bracing assumed to be 8' on-center maximum; stud lateral bracing at 1' on-center maximum.
- Beams and columns must remain straight to within $5L/4608$ (in.) of true alignment. L is the unrestrained length of the member in feet.

- If stud spacing is greater than 16" on-center, trusses or rafters must be installed within 3" of the stud locations.
- Deflections are based on C&C pressures adjusted for ASD (0.6W) and multiplied by 0.7 (IRC Table R301.7 and IBC Table 1604.3).

$$\Delta = \frac{270 wL^4}{Ebd^3} + \frac{28.8 wL^2}{Ebd}$$

Δ = deflection (in.)
 w = uniform load (plf)
 L = span (ft)
 b = member width (in.)
 d = member depth (in.)
 E = modulus of elasticity (psi)

WIND TABLES

Wall Design Wind Pressure (PSF)⁽¹⁾⁽²⁾

Exposure Category ⁽³⁾	Effective Wind Area ⁽⁴⁾ (ft ²)	Basic Wind Speed (mph)												
		2015/2018/2021/2024 IRC/IBC (ASCE 7-10/7-16/7-22: 0.6W)												
		90	95	100	105	110	115	120	130	140	150	160	170	180
B	≤ 10	9.7	10.9	12.0	13.3	14.6	15.9	17.3	20.3	23.6	27.1	30.8	34.8	39.0
	50	8.8	9.8	10.9	12.0	13.2	14.4	15.7	18.4	21.3	24.5	27.8	31.4	35.2
	≥ 100	8.4	9.4	10.4	11.4	12.5	13.7	14.9	17.5	20.3	23.3	26.6	30.0	33.6
C	≤ 10	13.6	15.1	16.7	18.5	20.3	22.1	24.1	28.3	32.8	37.7	42.9	48.4	54.3
	50	12.3	13.7	15.1	16.7	18.3	20.0	21.8	25.6	29.7	34.0	38.7	43.7	49.0
	≥ 100	11.7	13.0	14.4	15.9	17.5	19.1	20.8	24.4	28.3	32.5	37.0	41.7	46.8
D	≤ 10	16.1	17.9	19.8	21.9	24.0	26.2	28.6	33.5	38.9	44.6	50.8	57.3	64.3
	50	14.5	16.2	17.9	19.8	21.7	23.7	25.8	30.3	35.1	40.3	45.9	51.8	58.1
	≥ 100	13.9	15.4	17.1	18.9	20.7	22.6	24.6	28.9	33.5	38.5	43.8	49.4	55.4

- Tabulated pressures are based on the Analytical Procedure defined in ASCE 7. Values assume a C&C member in the interior zone of an enclosed structure, with the following factors:
 - Risk/occupancy category II
 - Topographical factor of 1.0
 - Mean roof height of 33'
 - When designing in accordance with 2015/2018/2021/2024 IRC/IBC, the load combinations include a 0.6 factor for wind. Tabulated wind pressures in this table are reduced by 0.6 for direct use with the load tables in this guide.
 - Exposure categories are generally defined as follows (see ASCE 7):
 - B = Urban and suburban areas, wooded areas
 - C = Open terrain with scattered obstructions generally less than 30' in height
 - D = Flat, unobstructed areas
 - Effective Wind Area** is the span multiplied by the tributary width or L²/3, whichever is greater. For values of effective wind areas not listed, interpolation between 10 ft² and 100 ft² is allowed.
- Check local codes for any special wind pressures.

Effective Wind Area

Wall Height	Stud/Column Effective Wind Area (ft ²)
≥ 18'	100
16'	85
14'	65
12'	48
10'	33

- Values are based on L²/3 with a maximum of 100 ft².
- The effective wind area should not be confused with the tributary area, which is used to determine the amount of load applied to an individual member.

DESIGN EXAMPLE

Given

- Wall height = 18'
- Rough opening = 6'
- Exposure Category B
- 2024 IRC/IBC
- 110 mph basic wind speed
- Flexible exterior finish with interior gypsum board finish; walls support window mullions
- Maximum column vertical load = 5,000 lbs
- Maximum header vertical load = 250 plf

When designing with C&C pressures, the effective wind area (L²/3) helps determine the wall design wind pressure. A smaller effective wind area results in a higher wind pressure. The effective wind area should not be confused with the tributary area, which is used to determine the amount of load applied to an individual member.

1. Determine effective wind areas (ft²):

- For the studs and columns, refer to the **Effective Wind Area** table above. An 18' stud or column will have an effective wind area of 100 ft².
- For each header, consult the drawing at right and use the maximum value of the rough opening (L) multiplied by the tributary width or L²/3, whichever is greater.
 - For the top header in our example wall, use the maximum of either (6' x 4'-6" = 27 ft²) or (6²/3 = 12 ft²).
 - For the bottom header in our example wall, use the maximum of either (6' x 9' = 54 ft²) or (6²/3 = 12 ft²).

The effective wind areas calculate to 27 ft² for the top header and 54 ft² for the bottom header, so interpolation would be required to find exact pressures. For simplicity, we will use an effective wind area of 10 ft² for each header. This allows us to skip the interpolation exercise, and provides a more conservative wind pressure.

2. Determine design wind pressure:

Consult the **Wall Design Wind Pressure** table above, using the example wall's criteria of Exposure B, a 110 mph basic wind speed, and an effective wind area as calculated above:

- For studs/columns with an effective area of 100 ft², the wall design lateral wind pressure is 12.5 psf.
- For headers with an effective area of 10 ft², the wall design wind pressure is 14.6 psf.

3. Determine appropriate deflection criteria:

Consult the **Code Minimum Deflection Criteria** on page 2. Our example wall contains both windows (minimum L/175) and interior gypsum board (minimum L/180). Because the L/180 deflection is more restrictive, the wall should be designed using the L/180 deflection values in this guide.

Refer to stud, column, and header tables on pages 6–10 to design the components for this example wall.

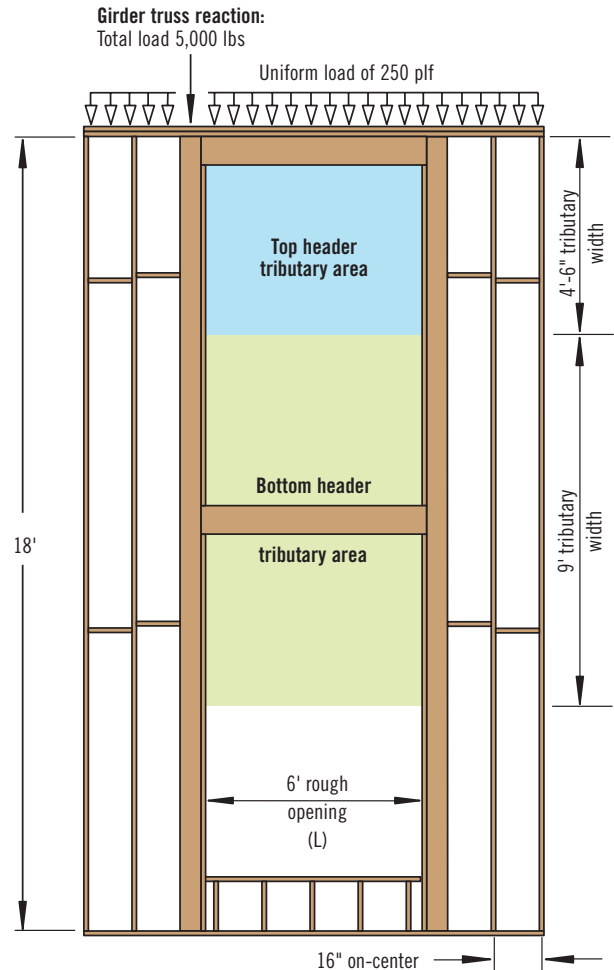

A complete wall specification should include permanent bracing, safety bracing, blocking, connections, details, etc. See pages 11–14.

STUD LOAD TABLE

Studs—Maximum Allowable Lateral (Wind) and Vertical Load

Wall Ht.	Load and Deflection	1.6E TimberStrand® LSL															
		1½" x 3½"				1½" x 5½"					1½" x 7¼"						
		Lateral Load (PLF)				Lateral Load (PLF)					Lateral Load (PLF)						
	15	20	26 ⁽¹⁾	30	15	20	26 ⁽¹⁾	30	40	50	15	20	26 ⁽¹⁾	30	40	50	
8'	Vertical (lbs)	2,790	2,790	2,790	2,790	4,385	4,385	4,385	4,385	4,385	4,385	5,775	5,775	5,775	5,775	5,775	5,775
	Defl. Ratio	L/834	L/625	L/481	L/417	L/3143	L/2357	L/1813	L/1571	L/1178	L/943	L/6952	L/5214	L/4011	L/3476	L/2607	L/2086
9'	Vertical (lbs)	2,790	2,790	2,610	2,495	4,385	4,385	4,385	4,385	4,385	4,385	5,775	5,775	5,775	5,775	5,775	5,775
	Defl. Ratio	L/588	L/441	L/339	L/294	L/2230	L/1672	L/1286	L/1115	L/836	L/669	L/4967	L/3725	L/2865	L/2483	L/1862	L/1490
10'	Vertical (lbs)	2,380	2,220	2,035	1,915	4,385	4,385	4,385	4,385	4,385	4,385	5,775	5,775	5,775	5,775	5,775	5,775
	Defl. Ratio	L/430	L/322	L/248	L/215	L/1637	L/1228	L/945	L/819	L/614	L/491	L/3666	L/2749	L/2115	L/1833	L/1375	L/1100
11'	Vertical (lbs)	1,935	1,770	1,585	1,465	4,385	4,385	4,385	4,385	4,385	4,385	5,775	5,775	5,775	5,775	5,775	5,775
	Defl. Ratio	L/324	L/243	L/187	L/162	L/1237	L/928	L/714	L/618	L/464	L/371	L/2780	L/2085	L/1604	L/1390	L/1042	L/834
12'	Vertical (lbs)	1,580	1,415	1,230	1,110	4,385	4,385	4,385	4,385	4,385	4,385	5,775	5,775	5,775	5,775	5,775	5,775
	Defl. Ratio	L/250	L/187	L/144	L/125	L/957	L/717	L/552	L/478	L/359	L/287	L/2156	L/1617	L/1244	L/1078	L/809	L/647
13'	Vertical (lbs)	1,290	1,130			4,385	4,385	4,385	4,385	4,195	3,755	5,775	5,775	5,775	5,775	5,775	5,775
	Defl. Ratio	L/197	L/148			L/755	L/566	L/436	L/377	L/283	L/226	L/1705	L/1279	L/984	L/853	L/640	L/512
14'	Vertical (lbs)	1,060				4,385	4,385	4,115	3,930	3,465	3,010	5,775	5,775	5,775	5,775	5,775	5,775
	Defl. Ratio	L/158				L/606	L/454	L/350	L/303	L/227	L/182	L/1372	L/1029	L/791	L/686	L/514	L/411
15'	Vertical (lbs)	870				4,055	3,800	3,510	3,315	2,845	2,385	5,775	5,775	5,775	5,775	5,775	5,775
	Defl. Ratio	L/128				L/494	L/370	L/285	L/247	L/185	L/148	L/1119	L/839	L/646	L/560	L/420	L/336
16'	Vertical (lbs)					3,545	3,285	2,990	2,795	2,320	1,845	5,775	5,775	5,775	5,775	5,775	5,775
	Defl. Ratio					L/408	L/306	L/235	L/204	L/153	L/122	L/925	L/694	L/534	L/462	L/347	L/277
17'	Vertical (lbs)					3,105	2,845	2,545	2,350	1,865		5,775	5,775	5,775	5,775	5,555	4,960
	Defl. Ratio					L/340	L/255	L/196	L/170	L/128		L/773	L/580	L/446	L/386	L/290	L/232
18'	Vertical (lbs)					2,725	2,460	2,160	1,965			5,775	5,775	5,665	5,415	4,800	4,195
	Defl. Ratio					L/287	L/215	L/166	L/143			L/653	L/489	L/376	L/326	L/245	L/196
19'	Vertical (lbs)					2,390	2,130	1,830	1,630			5,740	5,405	5,015	4,760	4,135	3,520
	Defl. Ratio					L/244	L/183	L/141	L/122			L/556	L/417	L/321	L/278	L/208	L/167
20'	Vertical (lbs)					2,105	1,840	1,540				5,175	4,835	4,440	4,180	3,550	2,925
	Defl. Ratio					L/210	L/157	L/121				L/477	L/358	L/275	L/239	L/179	L/143
21'	Vertical (lbs)					1,850	1,590					4,670	4,325	3,930	3,665	3,030	2,390
	Defl. Ratio					L/181	L/136					L/413	L/310	L/238	L/206	L/155	L/124
22'	Vertical (lbs)					1,630						4,220	3,875	3,470	3,210	2,565	
	Defl. Ratio					L/158						L/359	L/270	L/207	L/180	L/135	
23'	Vertical (lbs)					1,430						3,820	3,470	3,065	2,800		
	Defl. Ratio					L/138						L/315	L/236	L/182	L/157		
24'	Vertical (lbs)					1,255						3,455	3,105	2,700	2,435		
	Defl. Ratio					L/122						L/277	L/208	L/160	L/139		
25'	Vertical (lbs)											3,130	2,780	2,375	2,105		
	Defl. Ratio											L/246	L/184	L/142	L/123		
26'	Vertical (lbs)											2,840	2,485	2,080			
	Defl. Ratio											L/218	L/164	L/126			
27'	Vertical (lbs)											2,575	2,220				
	Defl. Ratio											L/195	L/146				
28'	Vertical (lbs)											2,330	1,980				
	Defl. Ratio											L/175	L/131				
29'	Vertical (lbs)											2,115					
	Defl. Ratio											L/158					
30'	Vertical (lbs)											1,915					
	Defl. Ratio											L/142					

(1) Load based on a wind pressure of 19.1 psf and studs spaced at 16" on-center

General Notes

- Table is based on:
 - Load duration factor of 1.6 for combined lateral (wind) and vertical load.
 - Load duration factor of 1.0 for vertical load only.
 - Stud lateral bracing in **Engineered Design Assumptions** on page 4.
 - Full-width blocking as required by code.
 - Vertical load eccentricity of ¼ of the member depth.
 - Reference compression perpendicular-to-grain stress of 425 psi adjusted per NDS® Section 3.10.4.
 - Repetitive-member bending strength increase of 4% per NDS® Section 8.3.7.
- Tabulated vertical loads apply to combined lateral (wind) + vertical loading and vertical loading only.
- Maximum allowable lateral (wind) loads reflect 0.6W as required by ASD load combinations in ASCE 7.

STUD EXAMPLE

Stud Example

For the **Design Example** on page 5, design 18' studs for lateral wind pressure of 12.5 psf and a maximum vertical load of 250 plf:

- **Determine the maximum stud length:**
The maximum stud length in this example wall is 18'.
- **Calculate the lateral load in plf:**
This example uses 16" on-center studs, so calculate the lateral load in plf and the vertical load in lbs as follows:
 $12.5 \text{ psf} \times 16/12 = 16.7 \text{ plf}$; $250 \text{ plf} \times 16/12 = 333 \text{ lbs}$.
- **Select the appropriate studs:**
In the **Stud Load Table**, scan across the 18' row until you find a cell in the 20 plf Lateral Load column that meets the L/180 deflection and the 333 lbs vertical load criteria. According to the table, a 1.6E TimberStrand® LSL 2x6 stud is an option.
- **Design stud connections:**
Convert 16.7 plf into a reaction (uniform load x length/2): $16.7 (18'/2) = 150 \text{ lbs}$. Use the **Lateral Connections** tables on page 13 to select a nail or angle clip connection that meets or exceeds 150 lbs. For this example, a nailed connection can be calculated as $150/104 = 1.5$, so two (0.131" x 3¼") pneumatic nails (nailed through the plate into the end grain) would work. For an angle clip connection, one Simpson Strong-Tie® A34 angle clip at the top and bottom plate is sufficient.

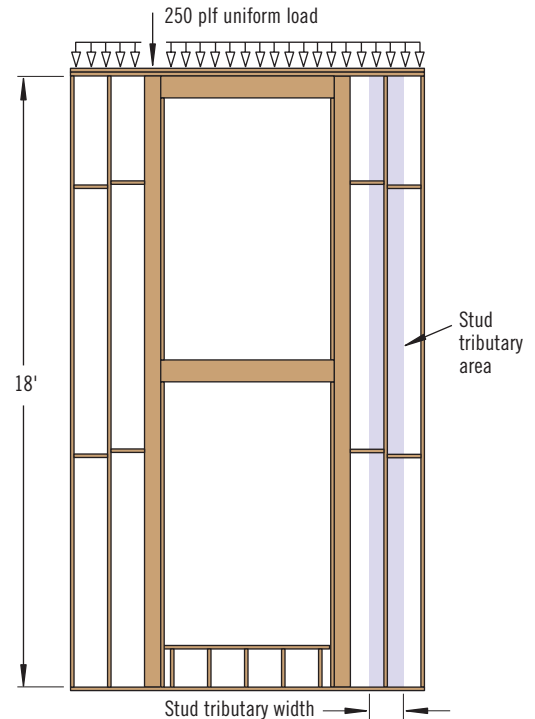

ONE-HOUR WALL ASSEMBLY WITH TIMBERSTRAND® LSL STUDS

2x6 Wall Application: 2x6 wall made with TimberStrand® LSL studs and gypsum wallboard applied horizontally. 2x6 or larger TimberStrand® LSL is permitted as a substitute in fire-rated assemblies when used in the same or larger dimensions as sawn lumber.

TimberStrand LSL Wall Assembly

1. 2x6 TimberStrand® LSL studs, spaced 16" on-center, with double top plates and single bottom plate
 2. 5/8" Type X gypsum wallboard, 4' wide, applied horizontally. Horizontal joints are unblocked. Horizontal application of wallboard represents the direction of least fire resistance as opposed to vertical application.
 3. 2¼" #6 Type S drywall screws, spaced along stud at 7" on-center and covered with joint compound
 4. Wallboard joints covered with paper tape and joint compound
- The design axial compressive stress within the TimberStrand® LSL studs must not exceed **the least** of the following:
 - 435 psi
 - $F_c \times 0.30$, where F_c is the compression design value parallel-to-grain for the TimberStrand® LSL, adjusted by all applicable factors (in accordance with the NDS®), including the column stability factor C_p
 - $F_c \times 0.30$, where F_c is calculated in accordance with the NDS®, assuming a slenderness ratio L_e/d of 21

This assembly has been tested to ASTM E119/NFPA 251 and CAN/ULC-S101 Standards.

Note: Additional options for fire-resistance-rated wall assemblies using TimberStrand® LSL studs are permissible based on calculations using the Fire Design Specification for Wood Construction (FDS).

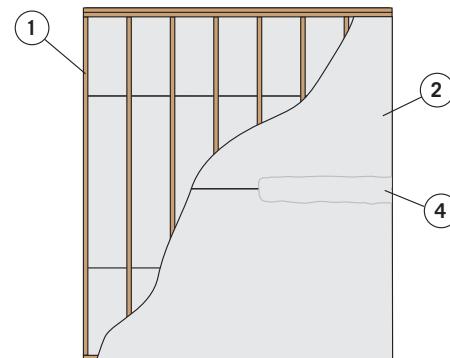

Top View (plates not shown)

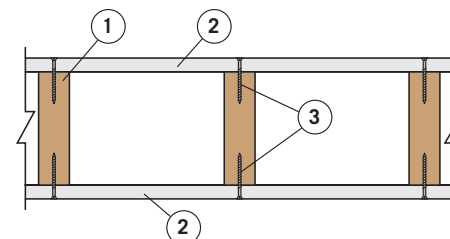

COLUMN LOAD TABLE

Columns—Maximum Allowable Lateral (Wind) Load (PLF)/Vertical Load (lbs)

Defl. Ratio	Wall Ht.	Max. Defl.	3½" Wall Thickness						5½" Wall Thickness						
			TimberStrand® LSL				Parallam® PSL		TimberStrand® LSL		Parallam® PSL				
			1.6E		1.3E		1.8E		1.6E	1.3E	1.8E		2.0E		
			Dbl 2x4 ⁽¹⁾	3½" x 3½"	5½" x 3½" (Plank)	7¼" x 3½" (Plank)	3½" x 3½"	5¼" x 3½" (Plank)	7" x 3½" (Plank)	Dbl 2x6 ⁽¹⁾	3½" x 5½"	3½" x 5¼"	5¼" x 5¼"	7" x 5¼" (Plank)	9½" x 5¼" (Plank)
L/360	30'	1.00"													
	28'	0.93"													
	26'	0.87"													
	24'	0.80"										23/8,160	34/11,670		
	22'	0.73"									22/7,070	30/9,380	45/13,415		
	20'	0.67"									29/8,230	39/10,955	60/15,615		
	18'	0.60"								23/4,550	22/5,105	27/6,465	40/9,655	54/12,830	82/18,390
	16'	0.53"							23/5,510	33/4,670	32/5,975	38/7,700	58/11,400	77/15,220	117/21,195
	14'	0.47"				25/5,070		25/5,160	34/6,850	50/4,705	47/6,885	57/7,810	86/11,715	115/15,620	174/21,195
	12'	0.40"	20/2,900		31/4,840	40/6,415	27/4,350	40/6,540	54/8,695	79/4,690	75/7,290	91/7,810	136/11,715	182/15,620	274/21,195
10'	0.33"	35/3,030	33/4,035	53/6,300	70/8,300	47/5,205	70/7,810	94/10,415	136/4,580	129/7,435	156/7,810	234/11,715	300/15,620	300/21,195	
8'	0.27"	69/3,045	65/4,735	103/8,180	136/10,785	91/5,205	136/7,810	182/10,415	261/4,355	248/7,200	300/7,810	300/11,715	300/15,620	300/21,195	
L/240	30'	1.50"													
	28'	1.40"													
	26'	1.30"													
	24'	1.20"										26/5,535	34/7,420	52/10,570	
	22'	1.10"									22/4,275	33/6,360	45/8,420	67/12,115	
	20'	1.00"							26/3,875	24/3,850	29/4,940	44/7,315	59/9,730	90/13,910	
	18'	0.90"							35/4,055	34/4,365	40/5,720	61/8,435	81/11,270	123/16,165	
	16'	0.80"				25/3,720		26/3,750	34/5,030	50/4,135	48/5,050	58/6,630	87/9,825	116/13,100	175/18,880
	14'	0.70"			29/3,425	38/4,525	25/3,100	38/4,630	51/6,160	75/4,125	71/5,650	86/7,750	129/11,525	173/15,315	261/21,195
	12'	0.60"	31/2,590	29/2,725	46/4,260	61/5,605	40/3,860	61/5,755	81/7,685	119/4,025	113/5,765	136/7,810	205/11,715	273/15,620	300/21,195
10'	0.50"	53/2,700	50/3,440	80/5,355	105/7,075	70/4,870	105/7,310	141/9,710	204/3,800	194/5,530	234/7,810	300/11,715	300/15,620	300/21,195	
8'	0.40"	104/2,665	98/3,870	155/6,755	204/8,915	136/5,205	205/7,810	267/10,415	300/4,075	300/6,200	300/7,810	300/11,715	300/15,620	300/21,195	
L/180	30'	2.00"													
	28'	1.87"													
	26'	1.73"													
	24'	1.60"							20/2,950		23/3,365	34/5,030	46/6,670	69/9,580	
	22'	1.47"							26/3,290	24/2,980	30/3,800	45/5,635	60/7,515	90/10,815	
	20'	1.33"							34/3,480	33/3,290	39/4,365	59/6,445	79/8,575	120/12,275	
	18'	1.20"							47/3,570	45/3,710	54/4,955	81/7,330	109/9,720	164/14,010	
	16'	1.07"			26/2,525	34/3,345	23/2,270	34/3,425	46/4,545	67/3,595	64/4,145	77/5,645	116/8,300	155/11,050	234/15,910
	14'	0.93"	26/2,160	24/1,960	39/3,035	51/4,015	34/2,755	51/4,130	68/5,510	100/3,525	95/4,420	115/6,345	173/9,335	230/12,480	300/20,250
	12'	0.80"	41/2,325	39/2,355	62/3,675	81/4,870	54/3,360	81/5,040	109/6,685	159/3,310	151/4,185	182/6,350	273/10,210	300/15,620	300/21,195
10'	0.67"	71/2,370	67/2,860	106/4,470	140/5,880	94/4,080	141/6,120	188/8,165	272/2,905	258/3,435	300/6,150	300/11,715	300/15,620	300/21,195	
8'	0.53"	138/2,275	131/2,990	206/5,170	267/6,955	182/4,370	267/7,430	267/10,415	300/4,075	300/6,200	300/7,810	300/11,715	300/15,620	300/21,195	

(1) For 3-ply and 4-ply built-up columns, multiply table values by 1.5 and 2.0, respectively. See page 11 for connection requirements.

▪ Green numbers refer to lateral (wind) load (plf). Black numbers refer to vertical load (lbs).

General Notes

- Tables are based on:
 - Load duration factor of 1.6 for combined lateral (wind) and vertical load.
 - Load duration factor of 1.0 for vertical load only.
 - Column lateral bracing in **Engineered Design Assumptions** on page 4.
 - Full-width blocking at a maximum vertical spacing of 8' on-center.
 - Vertical load eccentricity of ¼ of the member depth.
 - Reference compression perpendicular-to-grain stress of 425 psi.
- Tabulated vertical loads apply to combined lateral (wind) + vertical loading and vertical loading only.
- Solid sections required where specified. Built-up columns require reductions. Contact your Weyerhaeuser representative for assistance.
- Maximum allowable lateral (wind) loads reflect 0.6W as required by ASD load combinations in ASCE 7.

Beam Orientation

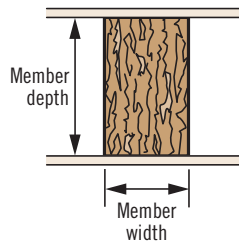

Plank Orientation

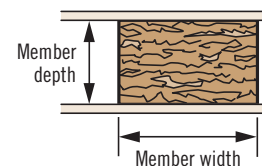

Some columns are listed in both beam and plank orientation. The first dimension is for member width, and the second dimension is for member depth (wall thickness).

TimberStrand® LSL and untreated Parallam® PSL are intended for dry-use applications

Not all products are available in all markets. Contact your Weyerhaeuser representative for information.

COLUMN LOAD TABLE

Columns—Maximum Allowable Lateral (Wind) Load (PLF)/Vertical Load (lbs) *continued*

Defl. Ratio	Wall Ht.	Max. Defl.	7¼" Wall Thickness						9½" Wall Thickness		
			TimberStrand® LSL		Parallam® PSL				TimberStrand® LSL	Parallam® PSL	
			1.6E	1.3E	1.8E		2.0E	1.55E	2.0E		
			Dbl 2x8 ⁽¹⁾	3½" x 7¼"	3½" x 7"	5¼" x 7"	7" x 7"	9½" x 7" (Plank)	3½" x 9½"	3½" x 9½"	5¼" x 9½"
L/360	30'	1.00"				21/9,050	28/11,955	42/16,780	30/11,205	38/12,275	58/20,135
	28'	0.93"				25/10,170	34/13,370	52/18,725	36/12,435	47/13,365	71/21,195
	26'	0.87"			21/7,540	32/11,350	43/14,945	64/21,120	46/13,655	59/14,130	89/21,195
	24'	0.80"	23/5,840	21/6,545	27/8,485	40/12,865	54/16,900	82/23,835	58/14,130	75/14,130	112/21,195
	22'	0.73"	29/6,020	28/7,340	35/9,635	53/14,530	70/19,180	106/27,140	75/14,130	97/14,130	146/21,195
	20'	0.67"	39/6,090	37/8,345	47/10,415	70/15,620	94/20,825	141/28,265	100/14,130	129/14,130	193/21,195
	18'	0.60"	54/6,100	51/8,990	64/10,415	96/15,620	128/20,825	193/28,265	136/14,130	176/14,130	237/21,195
	16'	0.53"	77/6,065	73/9,355	91/10,415	136/15,620	182/20,825	267/28,265	193/14,130	249/14,130	267/21,195
	14'	0.47"	114/5,975	108/9,565	135/10,415	202/15,620	270/20,825	300/28,265	284/14,130	300/14,130	300/21,195
	12'	0.40"	179/5,805	170/9,495	212/10,415	300/15,620	300/20,825	300/28,265	300/14,130	300/14,130	300/21,195
10'	0.33"	300/5,540	289/9,060	300/10,415	300/15,620	300/20,825	300/28,265	300/14,130	300/14,130	300/21,195	
8'	0.27"	300/6,520	300/10,785	300/10,415	300/15,620	300/20,825	300/28,265	300/14,130	300/14,130	300/21,195	
L/240	30'	1.50"			21/5,385	31/8,180	42/10,720	63/15,120	45/9,690	58/10,470	87/17,375
	28'	1.40"	21/4,900	20/4,590	25/6,025	38/9,080	51/11,915	78/16,725	55/10,585	71/11,305	107/18,885
	26'	1.30"	27/5,040	25/5,080	32/6,645	48/10,060	64/13,220	97/18,650	69/11,500	89/12,135	133/20,590
	24'	1.20"	34/5,205	32/5,625	40/7,465	61/11,240	81/14,775	123/20,865	87/12,085	112/12,720	169/21,195
	22'	1.10"	44/5,305	42/6,220	53/8,290	79/12,615	106/16,470	160/23,370	113/12,340	146/12,985	194/21,195
	20'	1.00"	59/5,320	56/6,900	70/9,335	105/14,185	141/18,465	212/26,305	150/12,415	193/13,180	214/21,195
	18'	0.90"	81/5,280	77/7,250	96/10,180	144/15,620	192/20,760	237/28,265	204/12,270	237/14,130	237/21,195
	16'	0.80"	115/5,170	109/7,355	136/10,415	205/15,620	267/20,825	267/28,265	267/12,680	267/14,130	267/21,195
	14'	0.70"	171/4,950	162/7,170	202/10,415	300/15,620	300/20,825	300/28,265	300/14,130	300/14,130	300/21,195
	12'	0.60"	269/4,585	255/6,575	300/10,415	300/15,620	300/20,825	300/28,265	300/14,130	300/14,130	300/21,195
10'	0.50"	300/5,540	300/8,800	300/10,415	300/15,620	300/20,825	300/28,265	300/14,130	300/14,130	300/21,195	
8'	0.40"	300/6,520	300/10,785	300/10,415	300/15,620	300/20,825	300/28,265	300/14,130	300/14,130	300/21,195	
L/180	30'	2.00"	23/4,130	22/3,650	28/4,805	42/7,290	56/9,560	84/13,525	60/8,230	77/8,800	116/14,720
	28'	1.87"	29/4,300	27/3,990	34/5,305	51/8,050	68/10,545	104/14,800	73/8,880	95/9,285	142/15,790
	26'	1.73"	36/4,450	34/4,330	43/5,790	64/8,840	86/11,505	129/16,335	92/9,395	118/9,805	164/17,935
	24'	1.60"	46/4,525	43/4,735	54/6,420	81/9,765	109/12,660	164/17,975	116/9,650	150/9,945	178/21,195
	22'	1.47"	59/4,590	56/5,125	70/7,060	106/10,695	141/13,925	194/21,040	151/9,510	194/9,865	194/21,195
	20'	1.33"	79/4,535	75/5,475	94/7,670	141/11,730	188/15,175	214/26,175	200/9,165	214/12,005	214/21,195
	18'	1.20"	108/4,420	103/5,500	128/8,135	192/12,805	237/17,745	237/28,265	237/10,475	237/14,130	237/21,195
	16'	1.07"	154/4,170	146/5,220	182/8,000	267/13,960	267/20,825	267/28,265	267/12,680	267/14,130	267/21,195
	14'	0.93"	228/3,780	216/4,550	270/7,430	300/15,620	300/20,825	300/28,265	300/14,130	300/14,130	300/21,195
	12'	0.80"	300/4,110	300/4,825	300/10,415	300/15,620	300/20,825	300/28,265	300/14,130	300/14,130	300/21,195
10'	0.67"	300/5,540	300/8,800	300/10,415	300/15,620	300/20,825	300/28,265	300/14,130	300/14,130	300/21,195	
8'	0.53"	300/6,520	300/10,785	300/10,415	300/15,620	300/20,825	300/28,265	300/14,130	300/14,130	300/21,195	

(1) For 3-ply and 4-ply built-up columns, multiply table values by 1.5 and 2.0, respectively. See page 11 for connection requirements.

- Green numbers refer to lateral (wind) load (plf). Black numbers refer to vertical load (lbs).

COLUMN EXAMPLE

Column Example

For the **Design Example** wall on page 5, design 18' columns for lateral wind pressure of 12.5 psf and vertical loading of 5,000 lbs:

Note: Vertical load is the load applied to the top of the column, excluding the header reaction. The header reaction is assumed to transfer directly to the trimmers.

- Calculate the lateral load in plf:**
The calculated wind pressure in the example is 12.5 psf, so 12.5 x 3.67' tributary width = 45.9 plf.
- Select an appropriate column:**
Scan the L/180 section of the **Column Load Tables** to find a 18' column that meets or exceeds the 45.9 plf lateral load and the 5,000 lbs vertical load. For this example, a 5¼" x 5¼" 1.8E Parallam® PSL column (at 81/7,330) will work for a 2x6 wall.
- Design the column to wall plate connections:**
Convert 45.9 plf into a reaction (uniform load x length/2): 45.9 (18'/2) = 413 lbs. Use the **Lateral Connections** tables on page 13 to select a connection that meets or exceeds 413 lbs. For this example 413/545 = 0.76; so according to the **Angle Clips** table, one Simpson Strong-Tie® A34 connector is required at top and bottom. Weyerhaeuser recommends using connectors on **each side** at top and bottom of the column (four connectors total) to provide concentric loading.

Girder truss reaction:
Total load 5,000 lbs

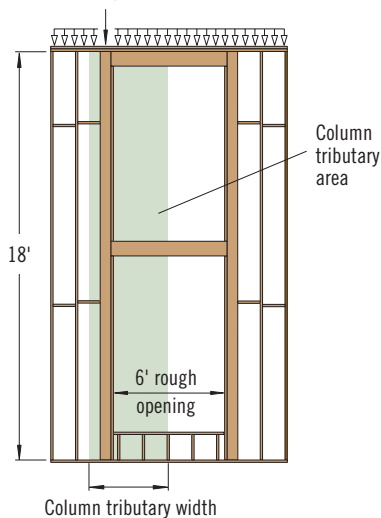

HEADER LOAD TABLE

Headers—Maximum Allowable Lateral (Wind) Load (PLF)/Vertical Load (PLF)

Lateral Def. Ratio	Rough Opening	Max. Def.	3½" Wall Thickness				5½" Wall Thickness			7¼" Wall Thickness
			TimberStrand® LSL				TimberStrand® LSL	Parallam® PSL		TimberStrand® LSL
			1.3E		1.55E		1.3E	1.8E	2.0E	1.3E
			3½" x 5½"	3½" x 7¼"	3½" x 9½"	3½" x 11⅞"	5½" x 3½" (Plank)	5¼" x 5¼"	5¼" x 9½"	7¼" x 3½" (Plank)
L/360	12'	0.41"	30/30	40/80	60/215	75/335		130/60	260/420	
	10'	0.34"	50/70	65/165	100/435	130/535	120/25	220/130	440/850	270/35
	9'	0.31"	65/110	90/250	140/575	175/695	165/40	295/200	490/1,265	365/55
	8'	0.28"	95/175	125/395	195/765	245/925	225/70	410/320	500/1,605	500/90
	7'	0.24"	140/295	180/650	285/1,040	310/1,220	330/120	500/535	500/1,830	500/160
	6'	0.21"	215/525	280/900	360/1,420	360/1,415	500/220	500/955	500/2,125	500/290
	5'	0.18"	355/690	430/1,230	430/1,690	430/1,685	500/370	500/1,525	500/2,535	500/485
	4'	0.14"	500/1,125	500/1,995	500/2,090	500/2,085	500/685	500/2,060	500/3,135	500/900
3'	0.11"	500/2,020	500/2,740	500/2,735	500/2,735	500/1,340	500/2,930	500/4,105	500/1,770	
L/240	12'	0.61"	45/30	60/80	90/215	115/295		195/60	370/420	
	10'	0.51"	75/70	100/165	155/380	190/460	180/25	325/130	440/850	405/35
	9'	0.46"	100/110	135/250	210/485	245/605	245/40	440/200	490/1,265	490/55
	8'	0.41"	140/175	185/395	275/655	275/885	340/70	500/320	500/1,605	500/90
	7'	0.36"	210/295	275/540	310/1,000	310/1,220	495/95	500/535	500/1,830	500/160
	6'	0.31"	320/380	360/750	360/1,420	360/1,415	500/220	500/955	500/2,125	500/290
	5'	0.26"	430/580	430/1,230	430/1,690	430/1,685	500/370	500/1,525	500/2,535	500/485
	4'	0.21"	500/1,125	500/1,995	500/2,090	500/2,085	500/685	500/2,060	500/3,135	500/900
3'	0.16"	500/2,020	500/2,740	500/2,735	500/2,735	500/1,340	500/2,930	500/4,105	500/1,770	
L/180	12'	0.82"	60/30	75/80	120/210	150/255		255/60	370/420	
	10'	0.68"	100/70	130/165	205/325	220/430	240/25	435/130	440/850	440/35
	9'	0.62"	135/110	175/250	245/440	245/605	325/40	490/200	490/1,265	490/55
	8'	0.55"	190/175	250/340	275/655	275/885	455/20	500/320	500/1,605	500/90
	7'	0.48"	275/225	310/470	310/1,000	310/1,220	500/90	500/535	500/1,830	500/160
	6'	0.42"	360/320	360/750	360/1,420	360/1,415	500/220	500/955	500/2,125	500/290
	5'	0.35"	430/580	430/1,230	430/1,690	430/1,685	500/370	500/1,525	500/2,535	500/485
	4'	0.28"	500/1,125	500/1,995	500/2,090	500/2,085	500/685	500/2,060	500/3,135	500/900
3'	0.22"	500/2,020	500/2,740	500/2,735	500/2,735	500/1,340	500/2,930	500/4,105	500/1,770	

- **Bold italic** values require two trimmers (3" bearing) at ends. Single trimmers may work for lightly loaded **bold italic** sections; see table below.
- **Green numbers** refer to lateral (wind) load (plf). Black numbers refer to vertical load (plf).

General Notes

- Table is based on:
 - Load duration factor of 1.6 for combined lateral (wind) and vertical load.
 - Load duration factor of 1.0 for vertical load only.
 - Uniform lateral (wind) and vertical loads (beam weight considered).
 - For vertical deflection, the more restrictive of L/240 or 5/16".
 - Maximum lateral (wind) load of 500 plf.
- Tabulated vertical loads apply to combined lateral (wind) + vertical loading and vertical loading only.
- Maximum allowable lateral (wind) loads reflect 0.6W as required by ASD load combinations in ASCE 7.

Bearing Requirements

- Trimmers must support the full width of the header.
- Minimum header support to be one trimmer (1½") at ends.

Maximum Allowable Vertical Load (PLF) with One Trimmer

Rough Opening	Wall Thickness	
	3½"	5½"
12'	355	536
10'	428	646
9'	476	718
8'	536	808
7'	613	924
6'	716	1,077
5'	858	1,291
4'	1,069	1,607
3'	1,415	2,126

HEADER EXAMPLE

Header Example

The **Design Example** on page 5 assumes that both headers will be the same size, and considers worst-case loading. Design the headers for lateral wind pressure of 14.6 psf based on the lower header's 6' rough opening and 10' tributary width, and a vertical load based on the upper header's maximum 250 plf.

- **Calculate the lateral load in plf:**

The calculated wind pressure in the example is 14.6 psf, so $14.6 \times 9'$ tributary width = 132 plf.

- **Select the appropriate header:**

Scan the L/180 section of the **Header Load Table** to find a header that meets your requirements (132 plf lateral and 250 plf vertical). For this example, a 6' header of $5\frac{1}{4}" \times 5\frac{1}{4}"$ 1.8E Parallam® PSL (at 500/955) will work for a 2x6 wall. Since the table number for this selection is not bold, only one trimmer stud is required for bearing. Headers that do not match the wall thickness must be directly attached to a plate that matches the wall thickness to provide lateral bracing. See detail L13 on page 12.

- **Design header to column connections:**

Convert 132 plf into a reaction (uniform load \times length/2): $132 (6'/2) = 396$ lbs. Use the **Lateral Connections** tables on page 13 to select a connection that meets or exceeds 396 lbs. For this example $396/545 = 0.73$; so according to the **Angle Clips** connections table on page 13, one Simpson Strong-Tie® A34 connector is required at each end. Weyerhaeuser recommends using connectors at top and bottom of the header (four connectors total) to provide concentric loading.

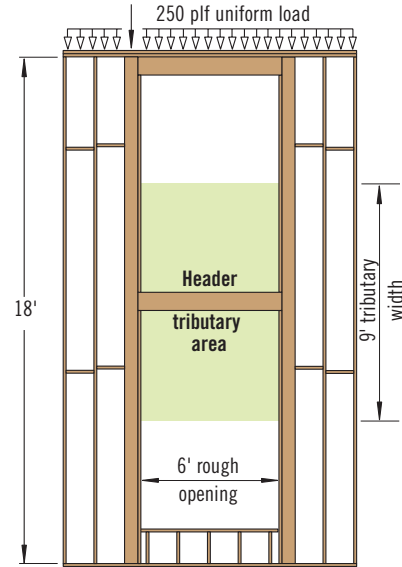

MULTIPLE-MEMBER CONNECTIONS

2-Ply Nailing Recommendations

- **For 2x4 and 2x6:** Minimum of **two rows** of (0.131" \times 3 $\frac{1}{4}"$) pneumatic nails at 10" on-center, staggered.
- Nail from one side.

3-Ply Nailing Recommendations

- **For 2x4:** Minimum of **two rows** of (0.131" \times 3 $\frac{1}{4}"$) pneumatic nails at 8" on-center, staggered.
- **For 2x6:** Minimum of **three rows** of (0.131" \times 3 $\frac{1}{4}"$) pneumatic nails at 5" on-center, staggered.
- Nail from both sides.

4-Ply Fastening Recommendations

- **For 2x4:** Nail each ply to the other with a minimum of **two rows** of (0.131" \times 3 $\frac{1}{4}"$) pneumatic nails at 5" on-center. When connecting each ply, offset nail rows by 2" from the ply below.
- **For 2x6:**
 - Nail each ply to the other with a minimum of **three rows** of (0.131" \times 3 $\frac{1}{4}"$) pneumatic nails at 5" on-center. When connecting each ply, offset nail rows by 2" from the ply below.
 - or,
 - Minimum of **two rows** of $\frac{1}{2}"$ diameter bolts spaced at 8" on-center.

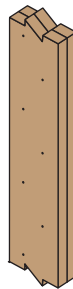

PRODUCT STORAGE



Protect product from sun and water

CAUTION:
Wrap is slippery when wet or icy

Align stickers (2x3 or larger) directly over support blocks

Use support blocks (6x6 or larger) at 10' on-center to keep bundles out of mud and water

TYPICAL TALL WALL FRAMING

WARNING

Safety bracing during construction is required for lateral stability. Lack of proper bracing or insufficient wall system design can result in serious accidents.

Wall reinforcement is required at all lift points to ensure wall stability during construction

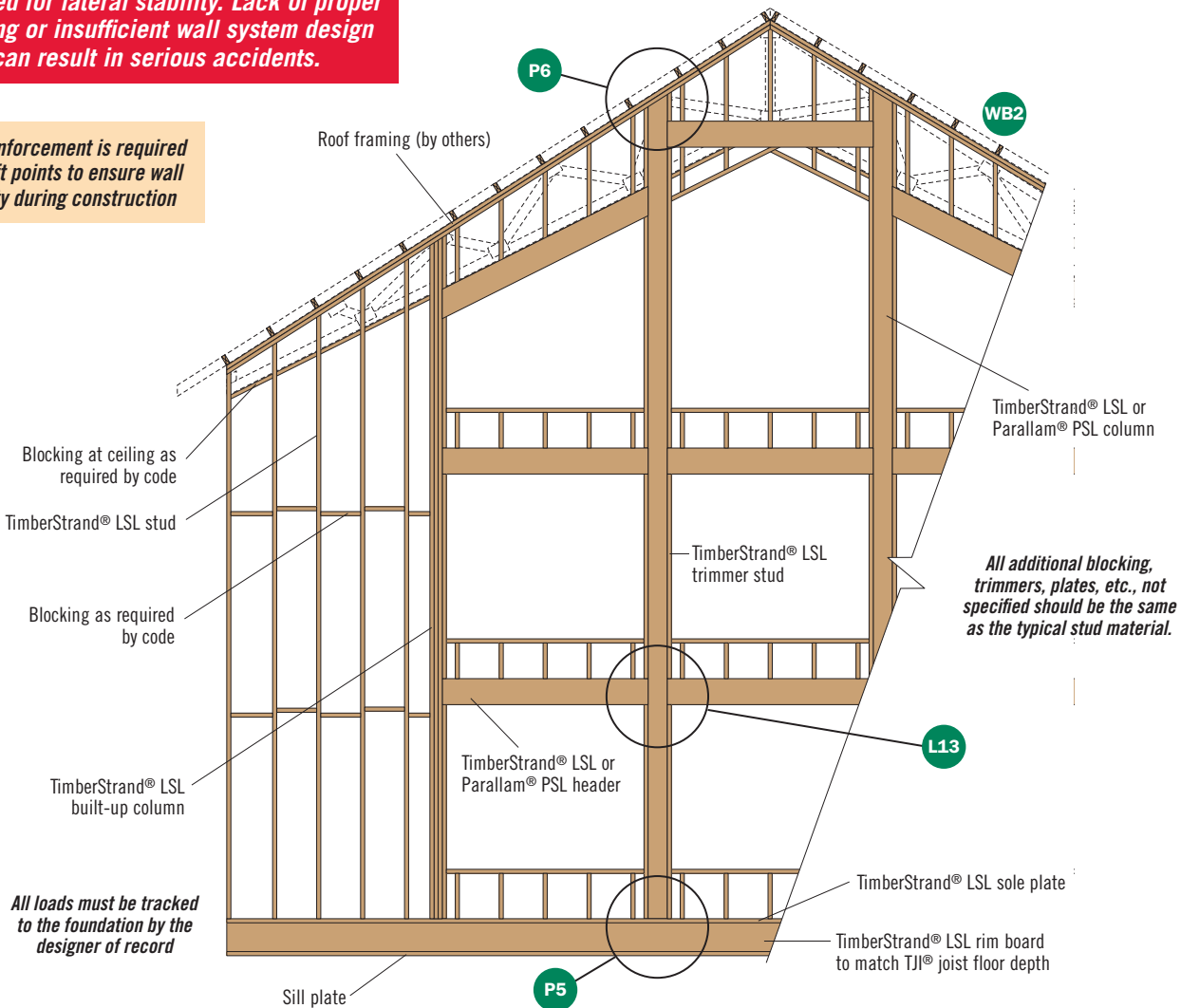

WALL DETAILS

Header to Column

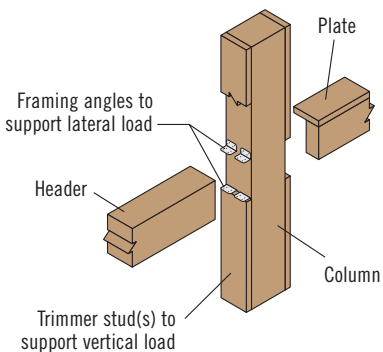

L13

Plate width must equal the wall thickness to provide lateral bracing. (Plate not required if header width equals the wall thickness.)

Column or Stud to Bottom Plate

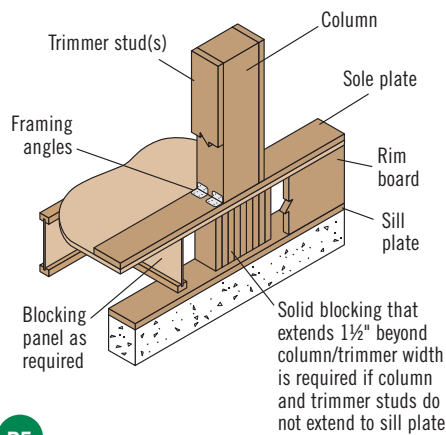

P5

Column or Stud to Top Plate

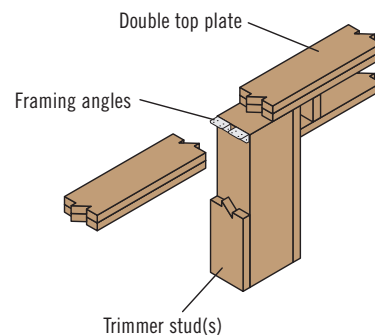

P6

WALL DETAILS

Wind Brace

Details shown are applicable for 115 mph basic wind speeds and the exposure categories and maximum wall heights shown in the table below. For other conditions, contact your Weyerhaeuser representative.

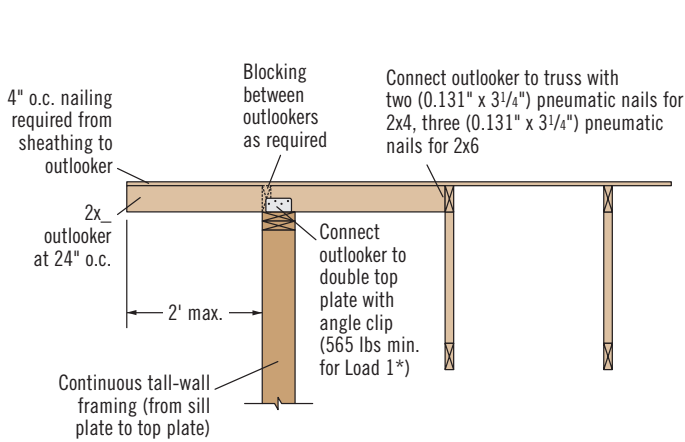

WB2 * Load 1 value from Lateral Connections—Angle Clips table below.

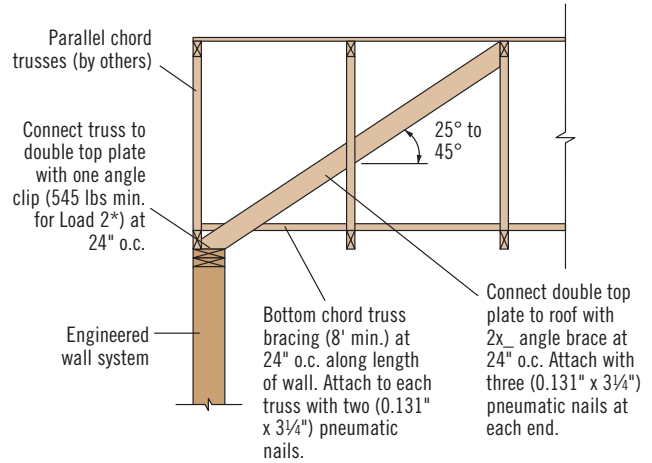

WB3 * Load 2 value from Lateral Connections—Angle Clips table below.

Wind Brace Detail Applicability

Detail	Exposure	Max. Wall Height
WB2	D	25'
	B, C	29'
WB3	B, C	20' ⁽¹⁾

(1) Maximum wall height shown includes depth of truss.

FRAMING CONNECTORS

Lateral Connections—Nails

Nail Size	End Grain	Toe Nail
8d (0.113" x 2½")	77 lbs	96 lbs
10d (0.128" x 3")	99 lbs	123 lbs
12d (0.128" x 3¼")	99 lbs	123 lbs
16d (0.135" x 3½")	110 lbs	137 lbs
(0.131" x 3¼")	104 lbs	129 lbs

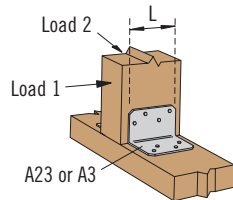

Lateral Connections—Angle Clips

Type	Nails	Length of Connector (L)	Load 1: Allowable Load (lbs)	Load 2: Allowable Load (lbs)
Simpson Strong-Tie®				
A21	Four 10d (0.148" x 1½")	1¾"	150	330
A34	Eight 8d (0.131" x 1½")	2½"	545	430
A35	Twelve 8d (0.131" x 1½")	4½"	650	670
A23	Eight 10d (0.148" x 1½")	2¾"	535	680
USP Structural Connectors®				
AC5	Six 10d (0.148" x 1½")	4⅞"	565	565
A3	Eight 10d (0.148" x 1½")	2¾"	740	605
AC7	Eight 10d (0.148" x 1½")	6⅛"	755	755
AC9	Ten 10d (0.148" x 1½")	8⅞"	945	900

General Notes

- Tables are based on a load duration factor of 1.60.
- Connection values based on a specific gravity of 0.50.
- For end-grain connections, a 0.67 factor was used (based on NDS®).
- For toenail connections, a 0.83 factor was used (based on NDS®).

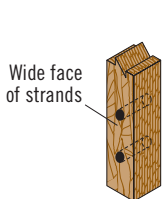

In order to use the manufacturer's published capacities when designing column caps, bases, or holdowns for uplift, the bolts or screws must be installed perpendicular to the wide face of strands as shown at left.



DO NOT install bolts or screws into the narrow face of strands

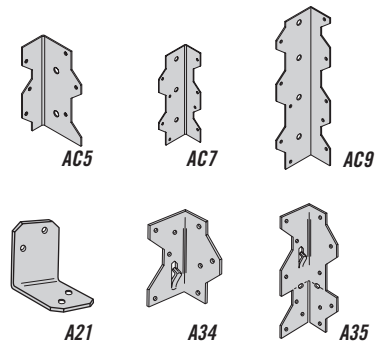

ALLOWABLE HOLES

1.55E TimberStrand® LSL Headers and Beams

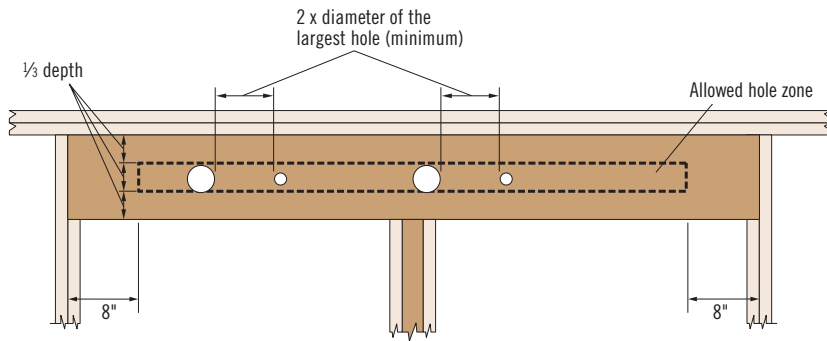

Other Trus Joist® Headers and Beams

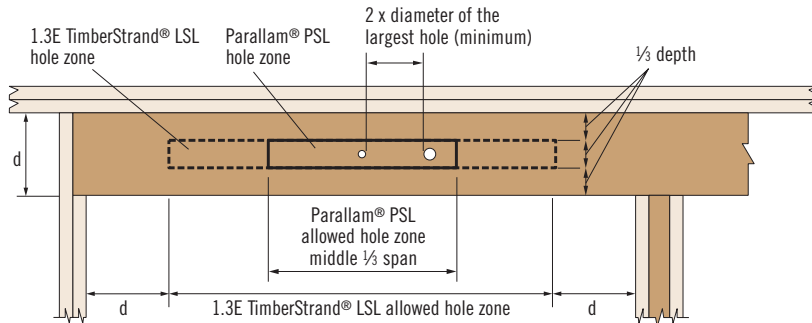

DO NOT cut, notch, or drill holes in headers or beams except as indicated in the illustrations and tables above

General Notes

- Allowed hole zone suitable for headers and beams with **uniform and/or concentrated loads** anywhere along the member.
- Round holes only.
- No holes in headers or beams in plank orientation.

1.55E TimberStrand® LSL

Header or Beam Depth	Maximum Round Hole Size
9½"	3"
11⅞"	3⅝"
14"-16"	4⅝"

- See illustration for allowed hole zone.

General Notes

- Allowed hole zone suitable for headers and beams with **uniform loads only**.
- Round holes only.
- No holes in cantilevers.
- No holes in headers or beams in plank orientation.

Other Trus Joist® Beams

Header or Beam Depth	Maximum Round Hole Size
5½"	1¾"
7¼"-20"	2"

- See illustration for allowed hole zone.

TimberStrand® LSL Studs

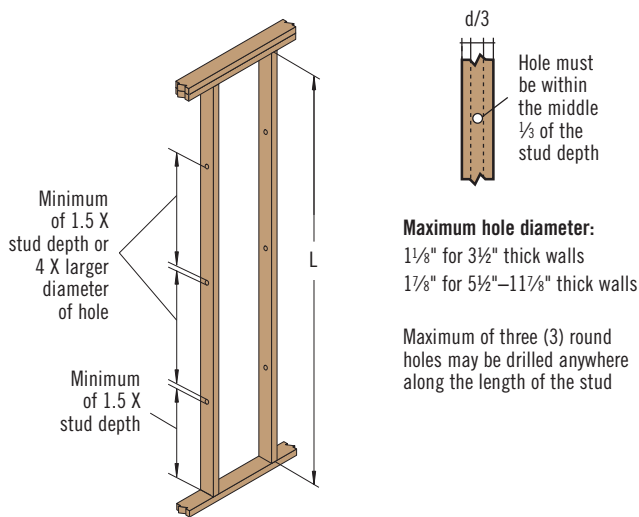

TimberStrand® LSL and Parallam® PSL Wall Columns

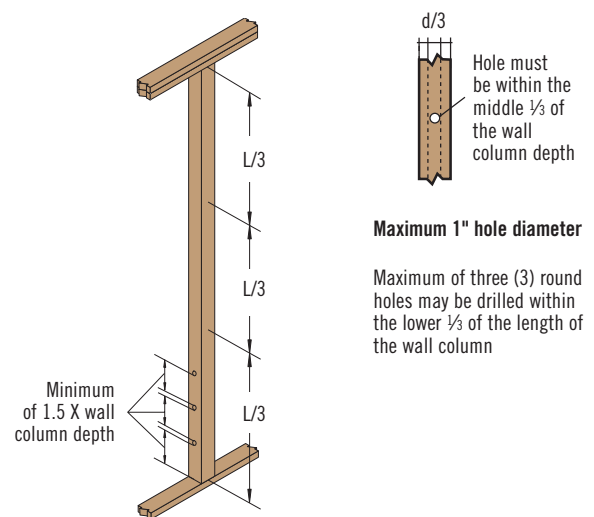

When using the load tables in this guide for studs or wall columns, holes may be drilled in accordance with the illustrations shown.



DO NOT notch studs and wall columns.

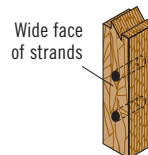

Beam Orientation

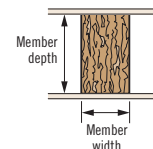

WARNING: This product can expose you to chemicals including wood dust which are known to the State of California to cause cancer, and methanol, which are known to the State of California to cause birth defects or other reproductive harm. Drilling, sawing, sanding or machining wood products can expose you to wood dust. Avoid inhaling wood dust or use a dust mask or other safeguards for personal protection. For more information go to www.P65Warnings.ca.gov and www.P65Warnings.ca.gov/wood.

Safety data sheets for all Weyerhaeuser wood products can be found on our website at: weyerhaeuser.com/sustainability/environment/product-stewardship/safety-data-sheets.

DESIGN PROPERTIES

Allowable Design Stresses (100% Load Duration)

Grade MOE (x10 ⁶) (psi)	E _{min} ⁽¹⁾ (psi)	Axial		Joist/Beam			Plank			Equivalent Specific Gravity for Connections			Min. Shear Wall Nail Spacing ⁽⁵⁾ (in.)
		F _c (psi)	F _t ⁽²⁾ (psi)	F _b ⁽³⁾ (psi)	F _v (psi)	F _{c⊥} ⁽⁴⁾ (psi)	F _b (psi)	F _v (psi)	F _{c⊥} ⁽⁴⁾ (psi)	Lateral	Withdrawal	Shear Walls ⁽⁵⁾	
TimberStrand® LSL													
1.3	660,750	1,835	1,300	1,700 ⁽⁶⁾	425	710	1,900	150	670	0.50	0.42	0.42 ⁽⁷⁾	6 ⁽⁷⁾
1.55	787,815	2,170	1,290 ⁽⁸⁾	2,325 ⁽⁶⁾	310 ⁽⁸⁾	900	2,615	150	775			0.42	2
1.6	813,230	2,235	2,060	2,425 ⁽⁶⁾	545	935	2,700	150	900			0.50	2
Parallam® PSL													
1.8	914,880	2,500	1,995	2,500 ⁽⁹⁾	230	545	2,400 ⁽⁹⁾	190	545	0.50	0.50	N.A.	N.A.
2.0	1,016,535	2,900 ⁽¹⁰⁾	2,300	2,900 ⁽⁹⁾	290	625	2,650 ⁽⁹⁾	210	635				

- Reference modulus of elasticity for beam and column stability calculations per NDS®.
- Referenced tension design values are based on a standard 4 foot length. For lengths longer than 4 foot, multiply F_t by the following adjustment (where L is length in feet):
– TimberStrand® LSL: (4/L)^{0.083} – Parallam® PSL: (4/L)^{0.056}
- When structural members qualify as repetitive members in accordance with the applicable building code, a 4% increase is permitted for F_b in addition to the increases permitted in footnotes 6 and 9.
- F_{c⊥} may not be increased for duration of load.
- Design shear wall applications per AWC SDPWS. When using StrandGuard® TimberStrand® LSL sill plate, see *Specifier's Guide for StrandGuard® TimberStrand® LSL Sill Plates, Columns and Studs*, TJ-8100.

- For 12" depth. For depths < 3½", use the 3½" factor; for other depths, multiply by $\left[\frac{12}{d}\right]^{0.092}$.
- Do not use AWC SDPWS with nail spacings less than 6" on-center. Studs at boundary locations, where two panels abut, are allowed two rows at 6" on-center.
- Value accounts for large hole capabilities. See **Allowable Holes** on page 14.
- For 12" depth. For depths < 3½", use the 3½" factor; for other depths, multiply by $\left[\frac{12}{d}\right]^{0.111}$.
- For column and stud applications, use F_{c||} of 500 psi. Alternatively, refer to ICC-ES ESR-1387, Table 1, footnote 13.

Allowable Design Properties (100% Load Duration)

1½" TimberStrand® LSL Studs

Design Property	Beam Orientation		
	1.6E		
	3½"	5½"	7¼"
Moment (ft-lbs)	695	1,640	2,780
Shear (lbs)	1,910	3,000	3,950
Moment of Inertia (in. ⁴)	5	21	48
Weight (plf)	1.6	2.6	3.4

3½" TimberStrand® LSL Columns and Headers

Design Property	1.3E						1.55E	
	Beam Orientation			Plank Orientation			Beam Orientation	
	3½"	5½"	7¼"	5½"	7¼"	9½"	11⅞"	
Moment (ft-lbs)	1,135	2,685	4,550	1,780	2,345	10,420	15,955	
Shear (lbs)	1,225	5,455	7,190	1,925	2,540	6,870	8,590	
Moment of Inertia (in. ⁴)	13	49	111	20	26	250	488	
Weight (plf)	3.6	5.6	7.4	5.6	7.4	10.4	13.0	

3½" Parallam® PSL Columns

Design Property	1.8E				2.0E	
	Beam Orientation		Plank Orientation		Beam Orientation	
	3½"	5¼"	7"	5¼"	7"	9½"
Moment (ft-lbs)	1,640	3,670	6,320	2,460	3,275	13,055
Shear (lbs)	1,550	2,820	3,755	2,330	3,105	6,430
Moment of Inertia (in. ⁴)	13	42	100	19	25	250
Weight (plf)	3.8	5.7	7.7	5.7	7.7	10.4

Beam Orientation

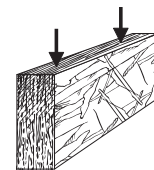

5¼" Parallam® PSL Columns and Headers

Design Property	1.8E			2.0E	
	Beam Orientation		Plank Orientation	Beam Orientation	Plank Orientation
	5¼"	7"	7"	9½"	9½"
Moment (ft-lbs)	5,285	9,485	7,050	19,585	10,565
Shear (lbs)	3,490	5,635	4,655	9,645	6,985
Moment of Inertia (in. ⁴)	63	150	84	375	115
Weight (plf)	8.6	11.5	11.5	15.6	15.6

Column Orientation



7" Parallam® PSL Columns

Design Property	1.8E		2.0E
	Beam Orientation		Plank Orientation
	7"		9½"
Moment (ft-lbs)	12,140		18,190
Shear (lbs)	6,205		9,310
Moment of Inertia (in. ⁴)	200		272
Weight (plf)	15.3		20.8

Plank Orientation

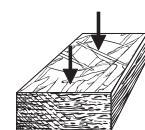

WE CAN HELP YOU BUILD SMARTER

You want to build solid and durable structures—we want to help. Weyerhaeuser provides high-quality building products and unparalleled technical and field assistance to support you and your project from start to finish.

Floors and Roofs: Start with the best framing components in the industry: our Trus Joist® TJI® joists; TimberStrand® LSL rim board; and TimberStrand® LSL, Microllam® LVL, and Parallam® PSL headers and beams. Pull them all together with our self-gapping and self-draining Weyerhaeuser Edge Gold™ floor panels and durable Weyerhaeuser roof sheathing.

Walls: Get the best value out of your framing package—use TimberStrand® LSL studs for tall walls, kitchens, and bathrooms, and our traditional, solid-sawn lumber everywhere else. Cut down installation time by using TimberStrand® LSL headers for doors and windows, and Weyerhaeuser wall sheathing with its handy two-way nail lines.

Software Solutions: Whether you are a design professional or lumber dealer, Weyerhaeuser offers an array of software packages to help you specify individual framing members, create cut lists, manage inventories—even help you design a complete structural frame. Contact your Weyerhaeuser representative to find out how to get the software you need.

Technical Support: Need technical help? Weyerhaeuser has one of the largest networks of engineers and sales representatives in the business. Call us for help, and a skilled member from our team of experts will answer your questions and work with you to develop solutions that meet all your structural framing needs.



LIMITED LIFETIME PRODUCT WARRANTY

Weyerhaeuser provides limited lifetime warranties for all Trus Joist® branded products. Product information, installation instructions, and the full text of each product's limited warranty (including limitations and exclusions) are available on the Weyerhaeuser website, from your Weyerhaeuser representative, or by calling toll free: 888-453-8358.

Additionally, Weyerhaeuser offers limited warranties on a broad variety of its other products. To see complete details of all Weyerhaeuser product warranties, visit weyerhaeuser.com/woodproducts/warranty.

1.888.453.8358
[WEYERHAEUSER.COM/WOODPRODUCTS](http://weyerhaeuser.com/woodproducts)

Model 11000 December 2019. Weyerhaeuser and Trus Joist are registered trademarks of Weyerhaeuser NR. © 2024 Weyerhaeuser NR Company. All rights reserved. California residents, the limits of any personal obligations are called out for that purpose, please visit weyerhaeuser.com/product/0204.

CONTACT US

1.888.453.8358 • weyerhaeuser.com/woodproducts/contact

Contact your local representative or dealer at:

Visit weyerhaeuser.com/woodproducts/warranty for copies of this and other Trus Joist® Engineered Wood Product warranties.

June 2024 • Reorder TJ-9004

This document supersedes all previous versions. If this is more than one year old, contact your dealer or Weyerhaeuser rep.

 Weyerhaeuser, Forte, Microllam, Parallam, TimberStrand, and Trus Joist are registered trademarks and Edge Gold is a trademark of Weyerhaeuser NR. © 2024 Weyerhaeuser NR Company. All rights reserved. Printed in the USA.