



SPECIALTY ROOFING PRODUCTS

One Manufacturer. One Easy Solution. One Solid Guarantee.



Johns Manville

is a total roofing systems provider meeting the needs of the commercial and industrial roofing industry. JM can complement our renowned Peak Advantage® Guarantee with a full line of specialty roofing products that includes expansion joint covers, edge metal systems, roof vents and drains, tie-in flashing systems and fire barriers.

Johns Manville's specialty products support all low-slope commercial membrane systems. Make JM your single-source provider for all roofing components and accessories.

PRODUCTS DESIGNED TO ACCOMMODATE THREE TYPES OF MOVEMENT



Seismic

Expertly fabricated joint covers are available on openings up to 24" (610 mm) to accommodate calculated multidirectional seismic movement.



Expansion

Design solutions to allow expansion along arches and curved surfaces, as well as accommodate movement between building components such as atriums and window walls.



Thermal

Where extreme temperatures cause thermal movement, flexible closures are designed specifically to allow movement between building walls, roofs, pipes, ducts, tanks and bulk-carrying equipment.





Custom product design services available

The Specialty Roofing Products group has established its expert reputation by offering custom product designs and specially fabricated systems for building movement and closure problems.

No matter how challenging or unusual the design situation, JM can turn rough sketches into custom-manufactured, code-compliant systems:

- Expand-O-Flash® and Expand-O-Gard®
—Horizontal and vertical expansion joint covers
- PrestoLock™, Presto-Tite™ and PrestoStop™
—ES-1 certified fascia and coping edge metal systems

Architectural drawings and CSI format short- and long-form specifications are available. These custom-designed systems can be included in the Johns Manville Peak Advantage Guarantee.



EXPANSION JOINT COVERS

are effective, flexible, weatherproof exterior closures designed to accommodate openings between adjoining parts of a structure.

Expand-O-Flash

Expand-O-Flash can be used for a variety of standard and special applications. The unique design of Expand-O-Flash allows it to manage the movement of thermal expansion, settlement, new and existing junctions, differing roof deck materials and seismic movement.

- More than 40 years of proven design, fabrication and field performance
- Qualifies for Johns Manville Peak Advantage Guarantees
- Qualifies for 10-year repair/replacement warranty that covers labor and materials for replacement of expansion joint covers and factory-fabricated intersections (when installed in accordance with JM specifications and instructions)

BENEFITS OF USING JM'S EXPAND-O-FLASH

Contains nonreinforced bellows for both geometric and elastomeric movement.

Available in 10' (3.1 m) lengths, some styles available in 50' and 100' (15.2 m and 30.5 m) rolls (custom-length rolls are available upon request).

Includes peel-and-stick splice tabs and splice kits for labor savings.

Compatible with built-up, modified bitumen (SBS and APP) and single ply membranes.

Available in a variety of flange styles for various application requirements.

Labor-saving factory-fabricated intersections to fit most needs or custom designed for special needs.

CONSIDERATIONS WHEN CHOOSING THE RIGHT MATERIALS FOR YOUR JOBS

EPDM

Black EPDM is the most cost-effective solution and is recommended for installations where budget is a concern.

Black EPDM also offers the longest life expectancy and has a higher UV resistance.

White EPDM is available upon request for special design considerations.

NEOPRENE

Neoprene is recommended for use on roofs exposed to process oils or animal fats.

FLANGES

Galvanized steel is a cost-effective solution and is recommended for installations where budget is a concern.

Aluminum is recommended for areas where longer exposure to severe elements is required.

Stainless steel is effective on manufacturing facilities where corrosion could affect the metal's longevity. Stainless steel is recommended in coastal applications.

Copper is a long-lasting, durable and aesthetically pleasing metal generally used to match other copper metalwork.

Other available metals include, but are not limited to:

- Freedom Gray, Copper
- Kynar®*-coated steel or aluminum

* Kynar is a registered trademark of Arkema, Inc.

EXPANSION JOINTS

STYLE	CF CURB-TO-CURB			CF/EJ CURB-TO-WALL			EJ CANT-TO-CANT			EJ CANT-TO-WALL																																																																																																
MEMBRANE COMPATIBILITY Please refer to the relevant JM specification sheets for details.	MULTI-PLY: BUR APP SBS SINGLE PLY: TPO PVC EPDM						MULTI-PLY: BUR APP SBS SINGLE PLY: TPO EPDM																																																																																																			
FACTORY TRANSITIONS	YES						YES																																																																																																			
BELLOWS MATERIALS	EPDM Black or White**, Neoprene Black						EPDM Black or White**, Neoprene Black																																																																																																			
FLANGE MATERIALS	Galvanized, 26 ga (0.55 mm) Aluminum, 0.032" (0.81 mm) Stainless Steel, 0.018" (0.46 mm) Copper, 16 oz (453.59 g) Custom Metal						Galvanized, 26 ga (0.55 mm) Aluminum, 0.032" (0.81 mm) Stainless Steel, 0.018" (0.46 mm) Copper, 16 oz (453.59 g) Custom Metal																																																																																																			
BELLOWS SIZES*	<table border="1"> <thead> <tr> <th>Standard</th> <th>Curb-to-Curb Joint Opening (span)</th> <th>Vertical Mounting Height</th> <th>Foam Thickness</th> </tr> </thead> <tbody> <tr><td>4" (102 mm)</td><td>1'-2 5/8" (25 mm-67 mm)</td><td>N/A</td><td>3/8" (10 mm)</td></tr> <tr><td>6" (152 mm)</td><td>2 3/4" - 4" (70 mm-102 mm)</td><td>N/A</td><td>1/2" (13 mm)</td></tr> <tr><td>8" (203 mm)</td><td>4 1/8" - 5 1/4" (105 mm-133 mm)</td><td>N/A</td><td>1/2" (13 mm)</td></tr> <tr><td>10" (254 mm)</td><td>5 3/8" - 6 3/8" (136 mm-168 mm)</td><td>N/A</td><td>5/8" (16 mm)</td></tr> <tr><td>12" (305 mm)</td><td>6 3/4" - 8" (171 mm-152 mm)</td><td>N/A</td><td>3/4" (19 mm)</td></tr> </tbody> </table>	Standard	Curb-to-Curb Joint Opening (span)	Vertical Mounting Height	Foam Thickness	4" (102 mm)	1'-2 5/8" (25 mm-67 mm)	N/A	3/8" (10 mm)	6" (152 mm)	2 3/4" - 4" (70 mm-102 mm)	N/A	1/2" (13 mm)	8" (203 mm)	4 1/8" - 5 1/4" (105 mm-133 mm)	N/A	1/2" (13 mm)	10" (254 mm)	5 3/8" - 6 3/8" (136 mm-168 mm)	N/A	5/8" (16 mm)	12" (305 mm)	6 3/4" - 8" (171 mm-152 mm)	N/A	3/4" (19 mm)	<table border="1"> <thead> <tr> <th>Standard</th> <th>Curb-to-Wall Joint Opening (span)</th> <th>Vertical Mounting Height</th> <th>Foam Thickness</th> </tr> </thead> <tbody> <tr><td>4" (102 mm)</td><td>1'-2" (25 mm-51 mm)</td><td>2 1/2" (64 mm)</td><td>3/8" (10 mm)</td></tr> <tr><td>6" (152 mm)</td><td>2 1/8" - 3" (54 mm-76 mm)</td><td>3 3/4" (95 mm)</td><td>1/2" (13 mm)</td></tr> <tr><td>8" (203 mm)</td><td>3 1/8" - 4" (79 mm-102 mm)</td><td>5 1/8" (130 mm)</td><td>1/2" (13 mm)</td></tr> <tr><td>10" (254 mm)</td><td>4 1/8" - 5" (105 mm-127 mm)</td><td>6 3/8" (162 mm)</td><td>5/8" (16 mm)</td></tr> <tr><td>12" (305 mm)</td><td>5 1/8" - 6" (130 mm-152 mm)</td><td>7 1/2" (191 mm)</td><td>3/4" (19 mm)</td></tr> </tbody> </table>	Standard	Curb-to-Wall Joint Opening (span)	Vertical Mounting Height	Foam Thickness	4" (102 mm)	1'-2" (25 mm-51 mm)	2 1/2" (64 mm)	3/8" (10 mm)	6" (152 mm)	2 1/8" - 3" (54 mm-76 mm)	3 3/4" (95 mm)	1/2" (13 mm)	8" (203 mm)	3 1/8" - 4" (79 mm-102 mm)	5 1/8" (130 mm)	1/2" (13 mm)	10" (254 mm)	4 1/8" - 5" (105 mm-127 mm)	6 3/8" (162 mm)	5/8" (16 mm)	12" (305 mm)	5 1/8" - 6" (130 mm-152 mm)	7 1/2" (191 mm)	3/4" (19 mm)	<table border="1"> <thead> <tr> <th>Standard</th> <th>Cant-to-Cant Joint Opening (span)</th> <th>Vertical Mounting Height</th> <th>Foam Thickness</th> </tr> </thead> <tbody> <tr><td>4" (102 mm)</td><td>1'-2 5/8" (25 mm-67 mm)</td><td>N/A</td><td>3/8" (10 mm)</td></tr> <tr><td>6" (152 mm)</td><td>2 3/4" - 4" (70 mm-102 mm)</td><td>N/A</td><td>1/2" (13 mm)</td></tr> <tr><td>8" (203 mm)</td><td>4 1/8" - 5 1/4" (105 mm-133 mm)</td><td>N/A</td><td>1/2" (13 mm)</td></tr> <tr><td>10" (254 mm)</td><td>5 3/8" - 6 3/8" (136 mm-168 mm)</td><td>N/A</td><td>5/8" (16 mm)</td></tr> <tr><td>12" (305 mm)</td><td>6 3/4" - 8" (171 mm-152 mm)</td><td>N/A</td><td>3/4" (19 mm)</td></tr> </tbody> </table>	Standard	Cant-to-Cant Joint Opening (span)	Vertical Mounting Height	Foam Thickness	4" (102 mm)	1'-2 5/8" (25 mm-67 mm)	N/A	3/8" (10 mm)	6" (152 mm)	2 3/4" - 4" (70 mm-102 mm)	N/A	1/2" (13 mm)	8" (203 mm)	4 1/8" - 5 1/4" (105 mm-133 mm)	N/A	1/2" (13 mm)	10" (254 mm)	5 3/8" - 6 3/8" (136 mm-168 mm)	N/A	5/8" (16 mm)	12" (305 mm)	6 3/4" - 8" (171 mm-152 mm)	N/A	3/4" (19 mm)	<table border="1"> <thead> <tr> <th>Standard</th> <th>Cant-to-Wall Joint Opening (span)</th> <th>Vertical Mounting Height</th> <th>Foam Thickness</th> </tr> </thead> <tbody> <tr><td>4" (102 mm)</td><td>1'-2" (25-51 mm)</td><td>2 1/2" (64 mm)</td><td>3/8" (10 mm)</td></tr> <tr><td>6" (152 mm)</td><td>2 1/8" - 3" (54-76 mm)</td><td>3 3/4" (95 mm)</td><td>1/2" (13 mm)</td></tr> <tr><td>8" (203 mm)</td><td>3 1/8" - 4" (79-102 mm)</td><td>5 1/8" (130 mm)</td><td>1/2" (13 mm)</td></tr> <tr><td>10" (254 mm)</td><td>4 1/8" - 5" (105-127 mm)</td><td>6 3/8" (162 mm)</td><td>5/8" (16 mm)</td></tr> <tr><td>12" (305 mm)</td><td>5 1/8" - 6" (130-152 mm)</td><td>7 1/2" (191 mm)</td><td>3/4" (19 mm)</td></tr> </tbody> </table>	Standard	Cant-to-Wall Joint Opening (span)	Vertical Mounting Height	Foam Thickness	4" (102 mm)	1'-2" (25-51 mm)	2 1/2" (64 mm)	3/8" (10 mm)	6" (152 mm)	2 1/8" - 3" (54-76 mm)	3 3/4" (95 mm)	1/2" (13 mm)	8" (203 mm)	3 1/8" - 4" (79-102 mm)	5 1/8" (130 mm)	1/2" (13 mm)	10" (254 mm)	4 1/8" - 5" (105-127 mm)	6 3/8" (162 mm)	5/8" (16 mm)	12" (305 mm)	5 1/8" - 6" (130-152 mm)	7 1/2" (191 mm)	3/4" (19 mm)	<p>Standard</p> <p>4" (102 mm)</p> <p>6" (152 mm)</p> <p>8" (203 mm)</p> <p>10" (254 mm)</p> <p>12" (305 mm)</p> <p>Made-to-order</p>	<p>Standard</p> <p>4" (102 mm)</p> <p>6" (152 mm)</p> <p>8" (203 mm)</p> <p>10" (254 mm)</p> <p>12" (305 mm)</p> <p>Made-to-order</p>	<p>Standard</p> <p>4" (102 mm)</p> <p>6" (152 mm)</p> <p>8" (203 mm)</p> <p>10" (254 mm)</p> <p>12" (305 mm)</p> <p>Made-to-order</p>	<p>Standard</p> <p>4" (102 mm)</p> <p>6" (152 mm)</p> <p>8" (203 mm)</p> <p>10" (254 mm)</p> <p>12" (305 mm)</p> <p>Made-to-order</p>	<p>Standard</p> <p>4" (102 mm)</p> <p>6" (152 mm)</p> <p>8" (203 mm)</p> <p>10" (254 mm)</p> <p>12" (305 mm)</p> <p>Made-to-order</p>	<p>Standard</p> <p>4" (102 mm)</p> <p>6" (152 mm)</p> <p>8" (203 mm)</p> <p>10" (254 mm)</p> <p>12" (305 mm)</p> <p>Made-to-order</p>
Standard	Curb-to-Curb Joint Opening (span)	Vertical Mounting Height	Foam Thickness																																																																																																							
4" (102 mm)	1'-2 5/8" (25 mm-67 mm)	N/A	3/8" (10 mm)																																																																																																							
6" (152 mm)	2 3/4" - 4" (70 mm-102 mm)	N/A	1/2" (13 mm)																																																																																																							
8" (203 mm)	4 1/8" - 5 1/4" (105 mm-133 mm)	N/A	1/2" (13 mm)																																																																																																							
10" (254 mm)	5 3/8" - 6 3/8" (136 mm-168 mm)	N/A	5/8" (16 mm)																																																																																																							
12" (305 mm)	6 3/4" - 8" (171 mm-152 mm)	N/A	3/4" (19 mm)																																																																																																							
Standard	Curb-to-Wall Joint Opening (span)	Vertical Mounting Height	Foam Thickness																																																																																																							
4" (102 mm)	1'-2" (25 mm-51 mm)	2 1/2" (64 mm)	3/8" (10 mm)																																																																																																							
6" (152 mm)	2 1/8" - 3" (54 mm-76 mm)	3 3/4" (95 mm)	1/2" (13 mm)																																																																																																							
8" (203 mm)	3 1/8" - 4" (79 mm-102 mm)	5 1/8" (130 mm)	1/2" (13 mm)																																																																																																							
10" (254 mm)	4 1/8" - 5" (105 mm-127 mm)	6 3/8" (162 mm)	5/8" (16 mm)																																																																																																							
12" (305 mm)	5 1/8" - 6" (130 mm-152 mm)	7 1/2" (191 mm)	3/4" (19 mm)																																																																																																							
Standard	Cant-to-Cant Joint Opening (span)	Vertical Mounting Height	Foam Thickness																																																																																																							
4" (102 mm)	1'-2 5/8" (25 mm-67 mm)	N/A	3/8" (10 mm)																																																																																																							
6" (152 mm)	2 3/4" - 4" (70 mm-102 mm)	N/A	1/2" (13 mm)																																																																																																							
8" (203 mm)	4 1/8" - 5 1/4" (105 mm-133 mm)	N/A	1/2" (13 mm)																																																																																																							
10" (254 mm)	5 3/8" - 6 3/8" (136 mm-168 mm)	N/A	5/8" (16 mm)																																																																																																							
12" (305 mm)	6 3/4" - 8" (171 mm-152 mm)	N/A	3/4" (19 mm)																																																																																																							
Standard	Cant-to-Wall Joint Opening (span)	Vertical Mounting Height	Foam Thickness																																																																																																							
4" (102 mm)	1'-2" (25-51 mm)	2 1/2" (64 mm)	3/8" (10 mm)																																																																																																							
6" (152 mm)	2 1/8" - 3" (54-76 mm)	3 3/4" (95 mm)	1/2" (13 mm)																																																																																																							
8" (203 mm)	3 1/8" - 4" (79-102 mm)	5 1/8" (130 mm)	1/2" (13 mm)																																																																																																							
10" (254 mm)	4 1/8" - 5" (105-127 mm)	6 3/8" (162 mm)	5/8" (16 mm)																																																																																																							
12" (305 mm)	5 1/8" - 6" (130-152 mm)	7 1/2" (191 mm)	3/4" (19 mm)																																																																																																							
FLANGE	2" x 2"			Curb: 2" x 2" Wall: 4"			4"			4"																																																																																																
ROLL LENGTHS	10' (3.05 m)			10' (3.05 m)			10' (3.05 m) – Bellows sizes 4" to 12" (10.16 cm to 30.48 cm) only 50' (15.24 m) – Bellows sizes 4" to 8" (10.16 cm to 20.32 cm) only 100' (30.48 m) – Bellows sizes 4" to 8" (10.16 cm to 20.32 cm) only Custom lengths available upon request.			10' (3.05 m) – Bellows sizes 4" to 12" (10.16 cm to 30.48 cm) only 50' (15.24 m) – Bellows sizes 4" to 8" (10.16 cm to 20.32 cm) only 100' (30.48 m) – Bellows sizes 4" to 8" (10.16 cm to 20.32 cm) only Custom lengths available upon request.																																																																																																
MOUNTING SUBSTRATE	Single 2x Curb			Single 2x Curb			Cant Strip			Cant Strip																																																																																																
CONSIDERATIONS Refer to the Material Safety Data Sheet and product label prior to using this product. The Material Safety Data Sheet is available by calling (800) 922-5922 or on the Web at www.jm.com/roofing . For technical assistance, please call (800) 445-1500.	<p>Joint opening plus curb widths must be considered for bellows sizing on Style CF for application to curbs.</p> <p>*Based on a rule-of-thumb method for determining bellows widths for CF (Curb Form) and CF/EJ styles:</p> <p>Curb-to-Curb: Bellows Width = (outside wood curb to outside wood curb) – 4" x 1.5"</p> <p>Curb-to-Wall: Bellows Width = (outside wood curb to wall) – 2" x 2"</p> <p>Always round up to the next even number, and in all cases, anticipated movement should be considered for proper sizing.</p>						<p>*Based on a rule-of-thumb method for determining bellows widths for EJ styles:</p> <p>Cant-to-Cant: 1.5 x (the width of the joint) = Bellows Width</p> <p>Cant-to-Wall: 2.0 x (the width of the joint) = Bellows Width</p> <p>Always round up to the next even number, and in all cases, anticipated movement should be considered for proper sizing.</p>																																																																																																			
	** White EPDM not recommended for use in high-UV areas						** White EPDM not recommended for use in high-UV areas																																																																																																			

EXPANSION JOINTS

STYLE



EJ/WC CURB-TO-CURB COVER



EJ/WC CURB-TO-WALL COVER

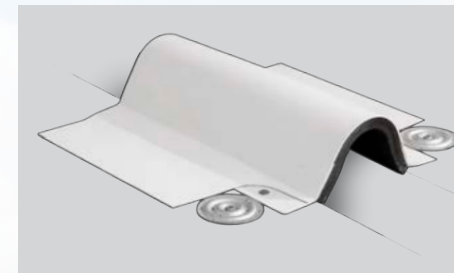

EJ/WC ROOF-TO-ROOF (PVC)

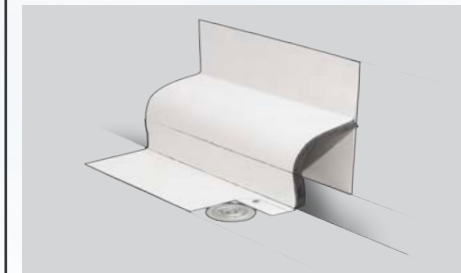

EJ/WC ROOF-TO-WALL (PVC)

MEMBRANE COMPATIBILITY
Please refer to the relevant JM specification sheets for details.

MULTI-PLY: BUR APP SBS
SINGLE PLY: TPO PVC EPDM

SINGLE PLY: PVC Only

FACTORY TRANSITIONS

YES

YES

BELLOWS MATERIALS

EPDM, PVC, Neoprene, White EPDM**

JM PVC White, Grey, Grey ES, Sandstone, Sandstone ES

NAIL STRIPS

1 3/8" (35 mm) nail strips are concealed beneath the cover membrane, and a 1" (25 mm) wide aluminum termination bar may be provided to securely hold the cover in place.

1 3/8" (35 mm) nail strips are concealed beneath the cover membrane, and a 1" (25 mm) wide aluminum termination bar may be provided to securely hold the cover in place.

BELLOWS SIZES*

Standard

4" (102 mm)

6" (152 mm)

8" (203 mm)

10" (254 mm)

12" (305 mm)

Made-to-order

Curb-to-Curb Joint Opening (span)	Vertical Mounting Height	Foam Thickness
1"-2 3/8" (25 mm-67 mm)	N/A	3/8" (10 mm)
2 3/4" - 4" (70 mm-102 mm)	N/A	1/2" (13 mm)
4 1/8" - 5 1/4" (105 mm-133 mm)	N/A	1/2" (13 mm)
5 3/8" - 6 3/8" (136 mm-168 mm)	N/A	5/8" (16 mm)
6 3/4" - 8" (171 mm-152 mm)	N/A	3/4" (19 mm)

Curb-to-Wall Joint Opening (span)	Vertical Mounting Height	Foam Thickness
1"-2" (25 mm-51 mm)	2 1/2" (64 mm)	3/8" (10 mm)
2 1/8" - 3" (54 mm-76 mm)	3 3/4" (95 mm)	1/2" (13 mm)
3 1/8" - 4" (79 mm-102 mm)	5 1/8" (130 mm)	1/2" (13 mm)
4 1/8" - 5" (105 mm-127 mm)	6 3/8" (162 mm)	5/8" (16 mm)
5 1/8" - 6" (130 mm-152 mm)	7 1/2" (191 mm)	3/4" (19 mm)

Curb-to-Curb Joint Opening (span)	Vertical Mounting Height	Foam Thickness
1"-2 3/8" (25 mm-67 mm)	N/A	3/8" (10 mm)
2 3/4" - 4" (70 mm-102 mm)	N/A	1/2" (13 mm)
4 1/8" - 5 1/4" (105 mm-133 mm)	N/A	1/2" (13 mm)
5 3/8" - 6 3/8" (136 mm-168 mm)	N/A	5/8" (16 mm)
6 3/4" - 8" (171 mm-152 mm)	N/A	3/4" (19 mm)

Curb-to-Wall Joint Opening (span)	Vertical Mounting Height	Foam Thickness
1"-2" (25 mm-51 mm)	2 1/2" (64 mm)	3/8" (10 mm)
2 1/8" - 3" (54 mm-76 mm)	3 3/4" (95 mm)	1/2" (13 mm)
3 1/8" - 4" (79 mm-102 mm)	5 1/8" (130 mm)	1/2" (13 mm)
4 1/8" - 5" (105 mm-127 mm)	6 3/8" (162 mm)	5/8" (16 mm)
5 1/8" - 6" (130 mm-152 mm)	7 1/2" (191 mm)	3/4" (19 mm)

Larger bellows sizes available upon request.

Larger bellows sizes available upon request.

COVER MEMBRANE WIDTH

11"-55" (28 cm-1.40 m) for EPDM or Neoprene; up to 78" (1.2 m) for PVC.

11"-78" (28 cm-1.2 m) depending on flashing and welding to the membrane requirements

ROLL LENGTHS

EPDM or Neoprene: Made-to-order sizes up to 100 lin ft (30.48 lin m).
Max roll length may vary based on cover width.

Maximum roll length may vary based on cover width.

PVC: Made-to-order sizes up to 50 lin ft (15 lin m).

CONSIDERATIONS

Refer to the Material Safety Data Sheet and product label prior to using this product. The Material Safety Data Sheet is available by calling (800) 922-5922 or on the Web at www.jm.com/roofing. For technical assistance, please call (800) 445-1500.

Joint opening plus curb widths must be considered for bellows sizing on Style EJ/WC for application to curbs.

Custom lengths are available upon request.

*Based on a rule-of-thumb method for determining bellows widths for EJ styles:

Curb-to-Curb: 1.5 x (the width of the joint) = Bellows Width

Curb-to-Wall: 2.0 x (the width of the joint) = Bellows Width

Do not install in direct contact with asphalt or coal tar pitch.

Refer to JM applicator guides or detail drawings for instructions.

Heat weldable directly to JM PVC membrane.

*Based on a rule-of-thumb method for determining bellow widths for EJ styles:

Roof-to-Roof: 1.5 x (the width of the joint) = Bellows Width

Roof-to-Wall: 2.0 x (the width of the joint) = Bellows Width

** White EPDM not recommended for use in high-UV areas

The Specialty Roofing Products group has established its expert reputation by offering custom designs and specially fabricated systems for building movement and closure problems.

No matter how challenging or unusual the design situation, JM can turn rough sketches into custom-manufactured systems.

These custom-designed systems can be included in the Johns Manville Peak Advantage Guarantee, one of the most comprehensive performance guarantees in the roofing industry. Here are a few examples of expansion joint transitions.

All styles are available with insulated bellows upon request.

EXPAND-O-FLASH Roof-to-Roof

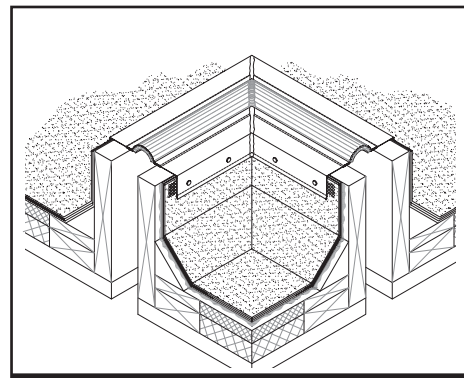

STYLE **CF PF-1**
TRANSITION **CORNER**

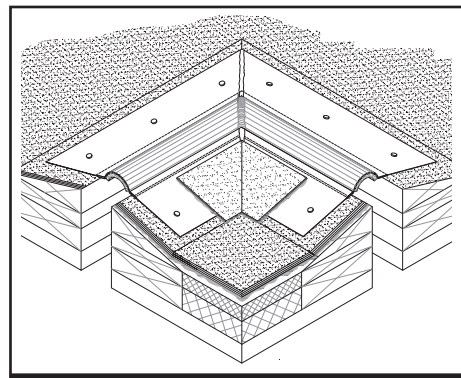

STYLE **EJ PF-11**
TRANSITION **CORNER**

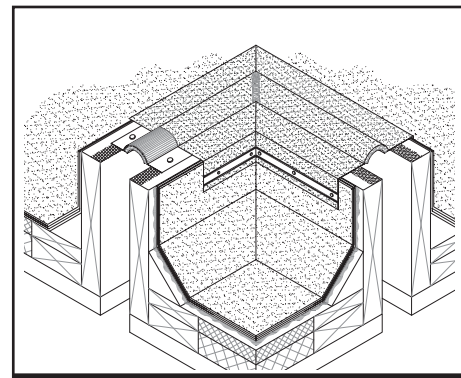

STYLE **EJ/WC PF-21**
TRANSITION **CORNER**

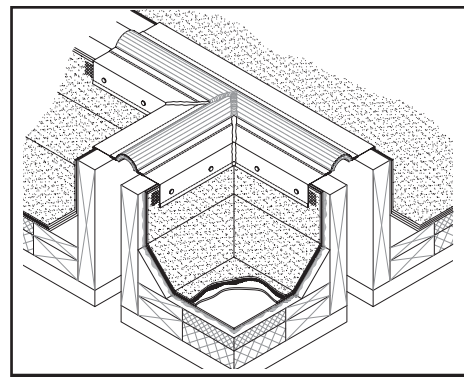

STYLE **CF PF-2**
TRANSITION **TEE**

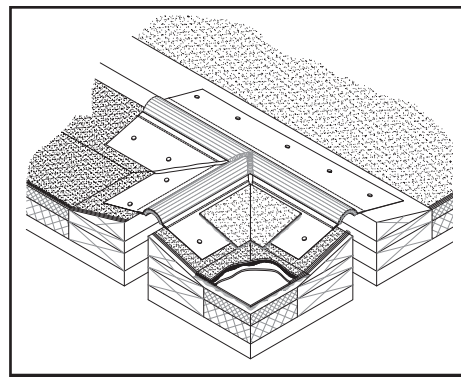

STYLE **EJ PF-12**
TRANSITION **TEE**

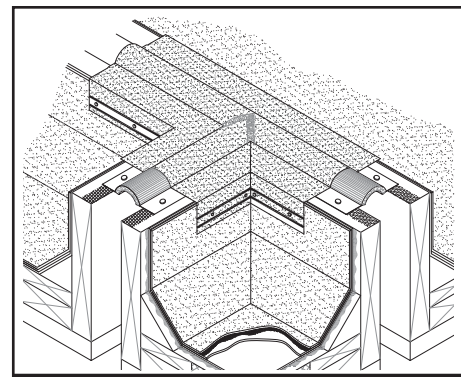

STYLE **EJ/WC PF-22**
TRANSITION **TEE**

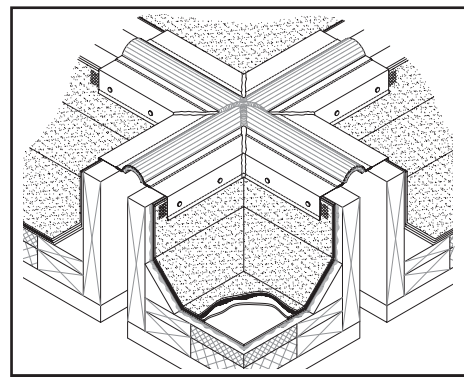

STYLE **CF PF-3**
TRANSITION **CROSS-OVER**

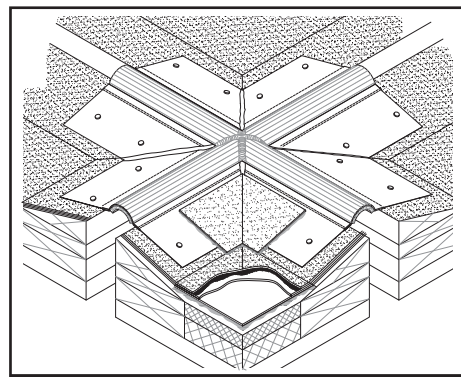

STYLE **EJ PF-13**
TRANSITION **CROSS-OVER**

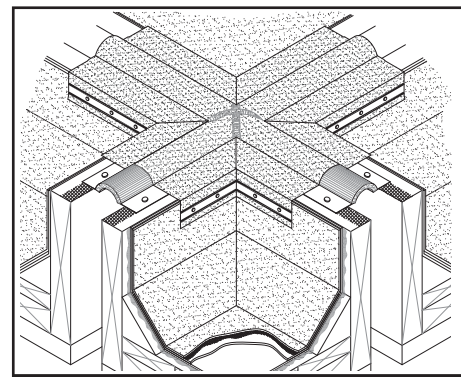

STYLE **EJ/WC PF-23**
TRANSITION **CROSS-OVER**

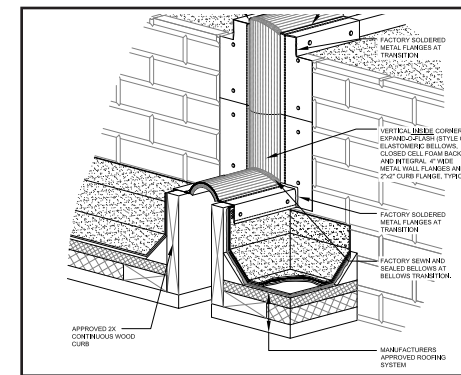

STYLE **CF PF-9**
TRANSITION **VERTICAL OUTSIDE CORNER**

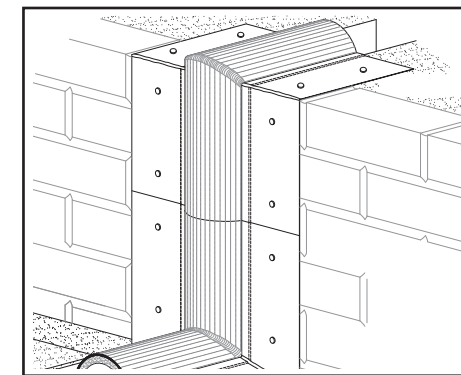

STYLE **EJ PF-19**
TRANSITION **VERTICAL OUTSIDE CORNER**

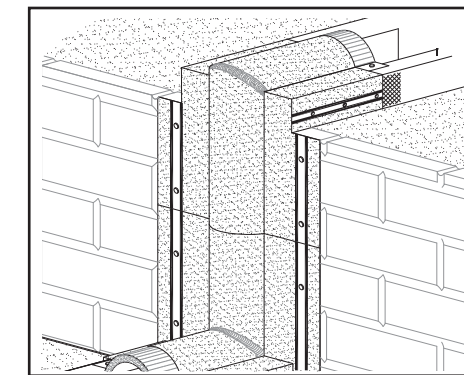

STYLE **EJ/WC PF-29**
TRANSITION **VERTICAL OUTSIDE CORNER**

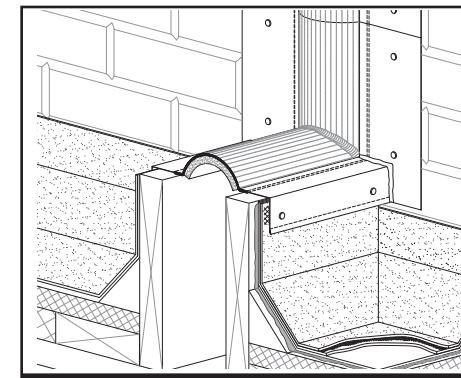

STYLE **CF PF-9**
TRANSITION **VERTICAL INSIDE CORNER**

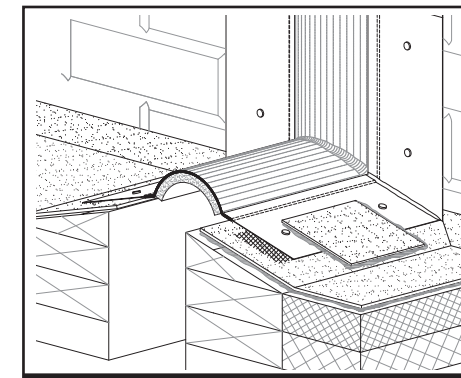

STYLE **EJ PF-19**
TRANSITION **VERTICAL INSIDE CORNER**

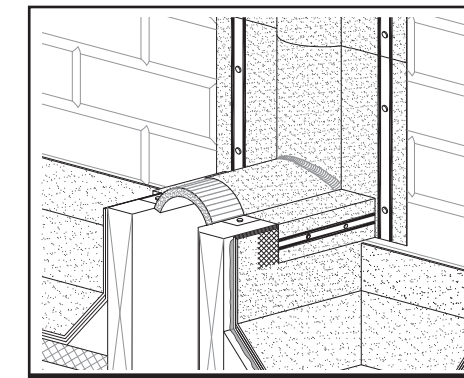

STYLE **EJ/WC PF-29**
TRANSITION **VERTICAL INSIDE CORNER**

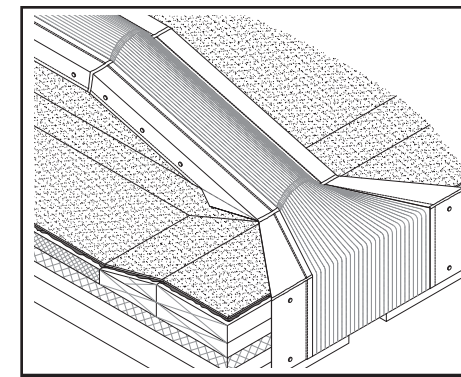

STYLE **CF FF-7**
TRANSITION **GRAVEL STOP**

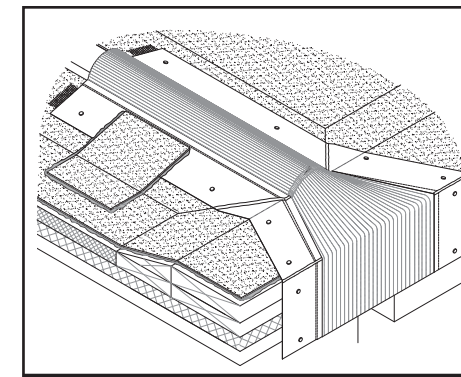

STYLE **EJ FF-17**
TRANSITION **GRAVEL STOP**

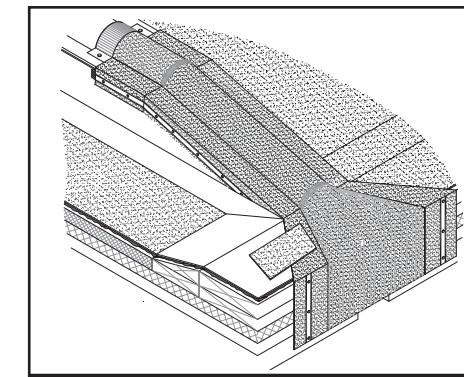

STYLE **EJ/WC FF-27**
TRANSITION **GRAVEL STOP**

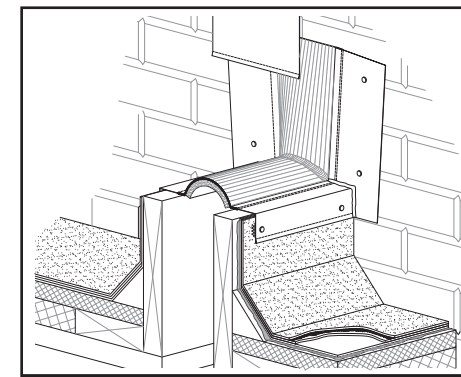

STYLE **CF FF-8**
TRANSITION **TERMINATION**

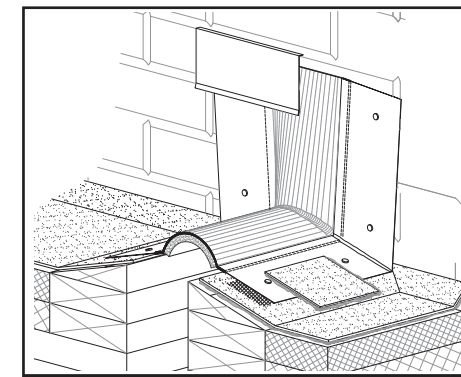

STYLE **EJ FF-18**
TRANSITION **TERMINATION**

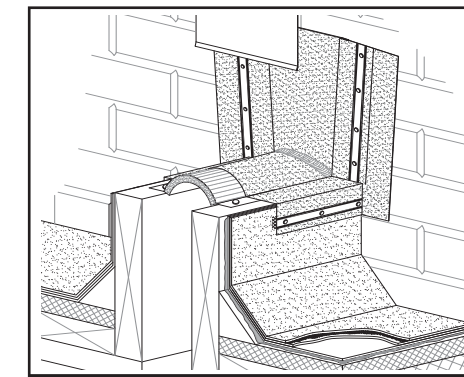

STYLE **EJ/WC FF-28**
TRANSITION **TERMINATION**

EXPAND-O-FLASH Roof-to-Wall

The Specialty Roofing Products group has established its expert reputation by offering custom designs and specially fabricated systems for building movement and closure problems.

No matter how challenging or unusual the design situation, JM can turn rough sketches into custom-manufactured systems.

These custom-designed systems can be included in the Johns Manville Peak Advantage Guarantee, one of the most comprehensive performance guarantees in the roofing industry. Here are a few examples of expansion joint transitions.

All styles are available with insulated bellows upon request.

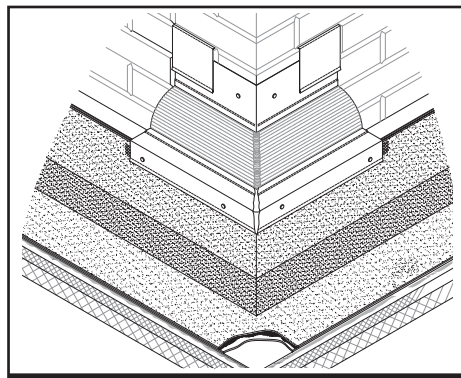

STYLE **CF/EJ PF-4**
TRANSITION **OUTSIDE CORNER**

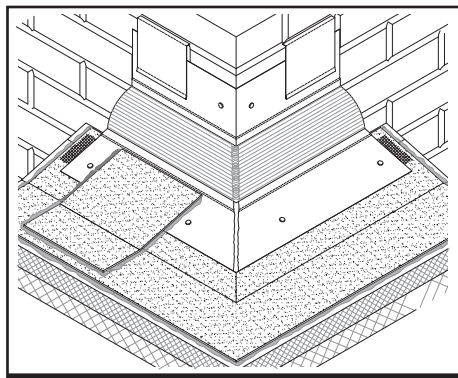

STYLE **EJ PF-14**
TRANSITION **OUTSIDE CORNER**

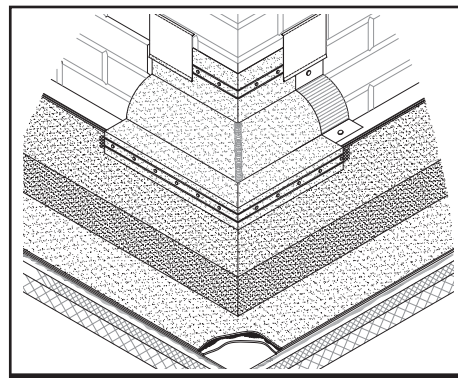

STYLE **EJ/WC PF-24**
TRANSITION **OUTSIDE CORNER**

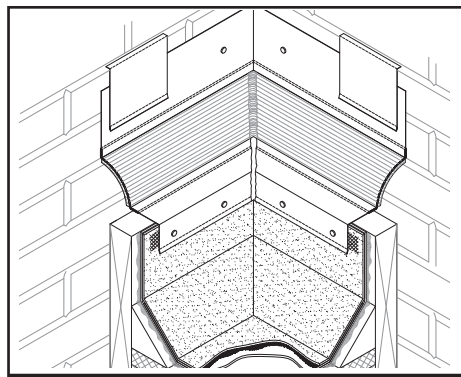

STYLE **CF/EJ PF-5**
TRANSITION **INSIDE CORNER**

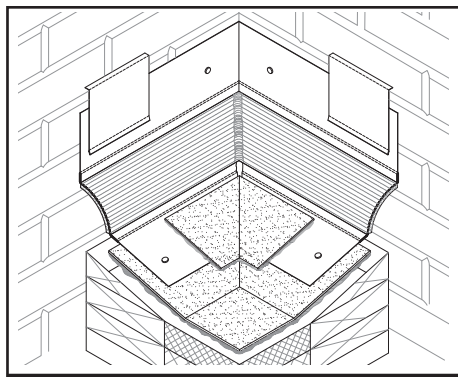

STYLE **EJ PF-15**
TRANSITION **INSIDE CORNER**

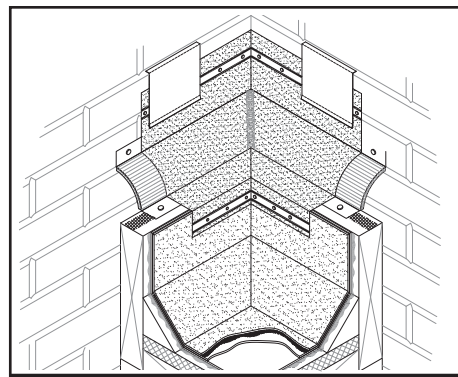

STYLE **EJ/WC PF-25**
TRANSITION **INSIDE CORNER**

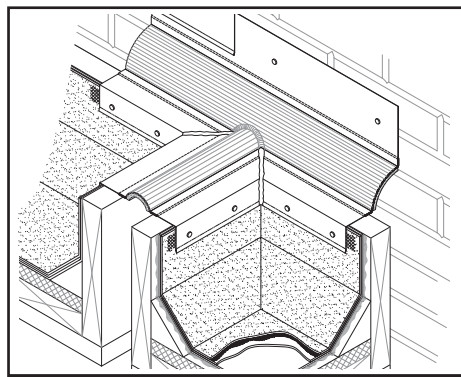

STYLE **CF/EJ PF-6**
TRANSITION **TEE**

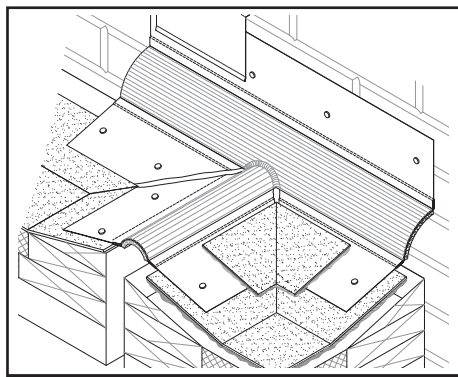

STYLE **EJ PF-16**
TRANSITION **TEE**

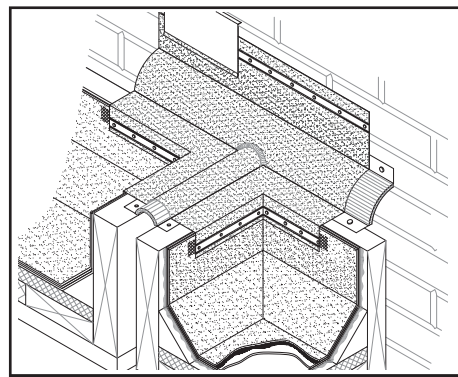

STYLE **EJ/WC PF-26**
TRANSITION **TEE**

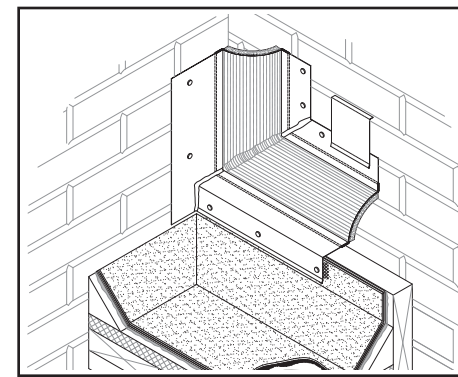

STYLE **CF/EJ PF-8**
TRANSITION **VERTICAL INSIDE CORNER**

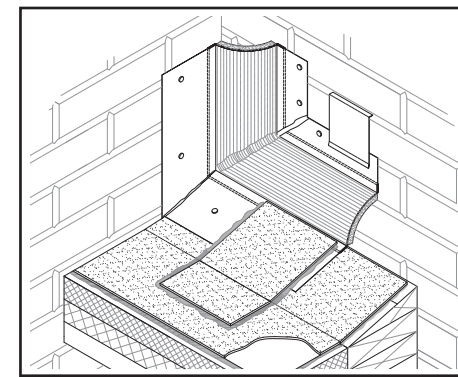

STYLE **EJ PF-18**
TRANSITION **VERTICAL INSIDE CORNER**

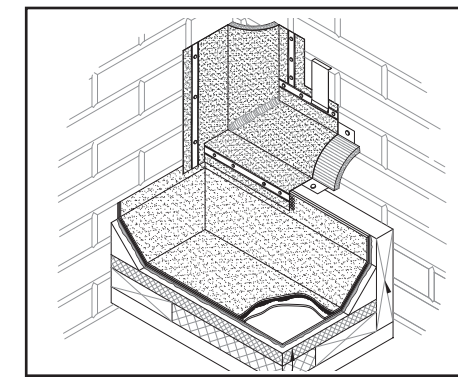

STYLE **EJ/WC PF-28**
TRANSITION **VERTICAL INSIDE CORNER**

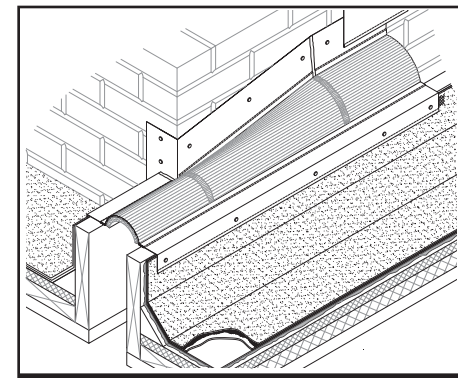

STYLE **CF/EJ FF-5**
TRANSITION **ROOF/WALL TO ROOF/ROOF**

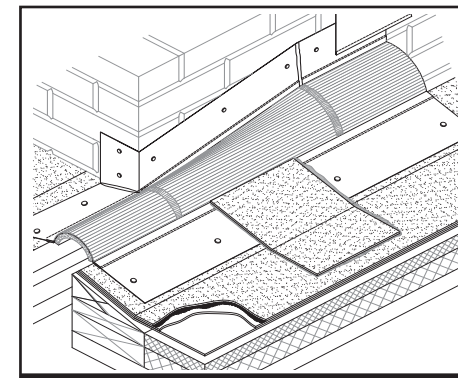

STYLE **EJ FF-15**
TRANSITION **ROOF/WALL TO ROOF/ROOF**

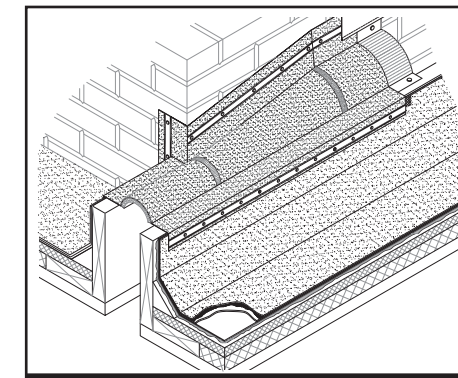

STYLE **EJ/WC FF-25**
TRANSITION **ROOF/WALL TO ROOF/ROOF**

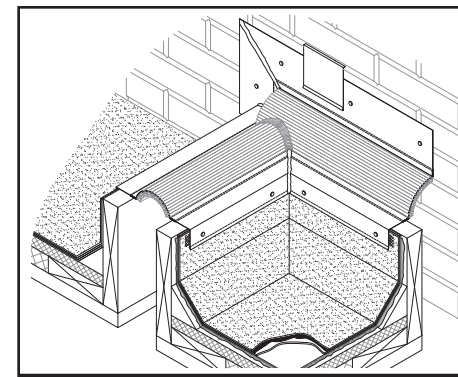

STYLE **CF/EJ PF-1/5**
TRANSITION **ROOF/WALL TO ROOF/ROOF**

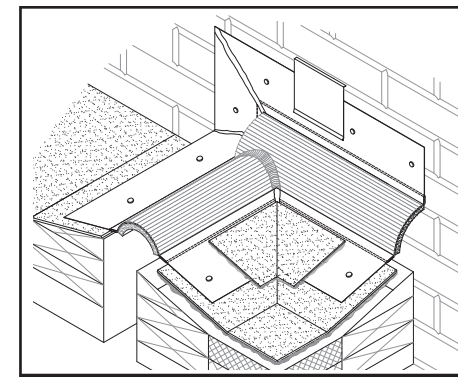

STYLE **EJ PF-11/15**
TRANSITION **ROOF/WALL TO ROOF/ROOF**

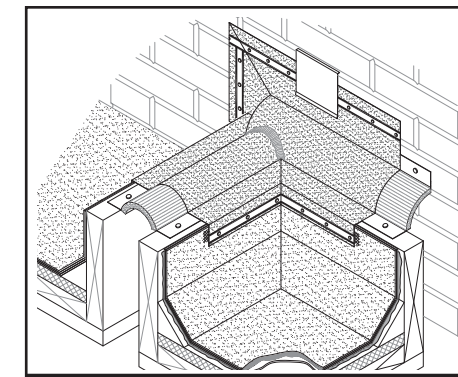

STYLE **EJ/WC PF-21/25**
TRANSITION **ROOF/WALL TO ROOF/ROOF**

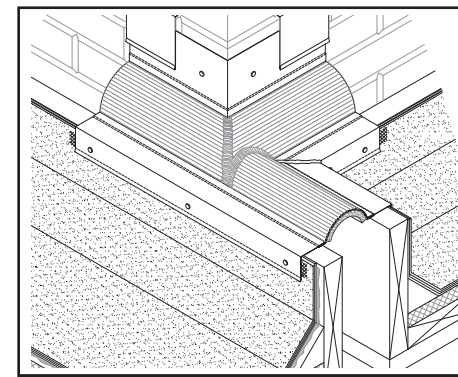

STYLE **CF/EJ PF-4/6**
TRANSITION **ROOF/WALL TO ROOF/ROOF**

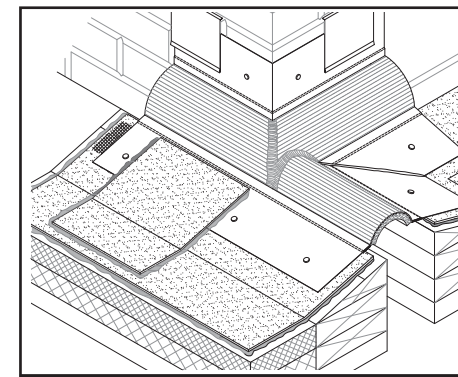

STYLE **EJ PF-14/16**
TRANSITION **ROOF/WALL TO ROOF/ROOF**

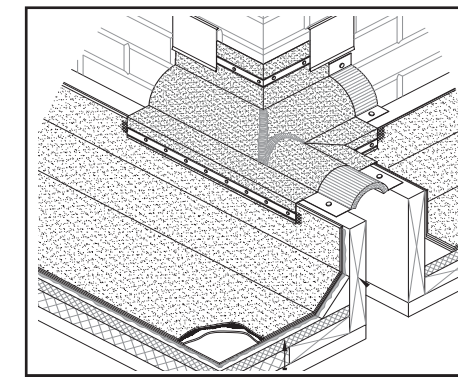

STYLE **EJ/WC PF-24/26**
TRANSITION **ROOF/WALL TO ROOF/ROOF**



EXPAND-O-FLASH WITH FIRE BARRIER

Where building codes require hourly fire ratings, any style Expand-O-Flash installed as part of a fire-rated assembly and protected by a Fireline 520®* fire barrier can provide a one-hour, two-hour or three-hour fire rating.

EXPAND-O-FLASH

Fire Barrier

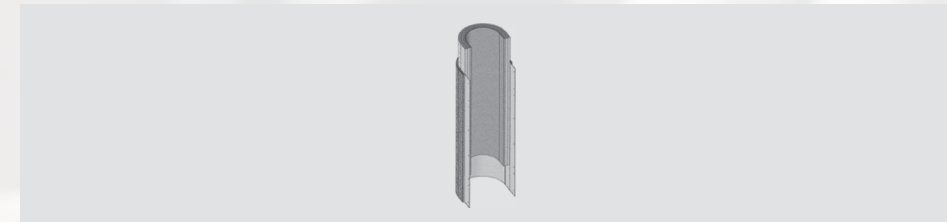

STYLE

HORIZONTAL-MOUNTED JOINTS

VERTICAL-MOUNTED JOINTS

MEMBRANE COMPATIBILITY
Please refer to the relevant JM specification sheets for details.

MULTI-PLY: BUR APP SBS
SINGLE PLY: TPO PVC EPDM

MULTI-PLY: BUR APP SBS
SINGLE PLY: TPO PVC EPDM

FACTORY TRANSITIONS

YES

YES

MOUNTING POSITIONS

Available in top, inside and bottom mount.

Available in top, inside and bottom mount.

SIZES

Openings from 2" to 32" (5.08 cm to 81.28 cm)

2" to 27" (5.08 cm to 68.58 cm)

MOVEMENT

25%, 50% and 100% movement.

25%, 50% and 100% movement.

RATINGS

One-, two- or three-hour fire ratings.

One-, two-, three- or four-hour fire ratings.

UL 2079, ASTM E 119, ASTM E 1399,
ASTM E 1966 and ULC S-115.

UL 2079, ASTM E 119, ASTM E 1399,
ASTM E 1966 and ULC S-115.

INSTALLATION

Factory-made and ready to install out of the box,
reducing installation time.

Factory-made and ready to install out of the box,
reducing installation time.

Standard male/female joint system ensures fire barrier integrity.

Standard male/female joint system ensures fire barrier integrity.

Factory-made transitions eliminate need to
miter or otherwise modify parts on site.

Factory-made transitions eliminate need to
miter or otherwise modify parts on site.

CONSIDERATIONS

Listed by Warnock Hersey and Guardian Fire Testing Laboratories Inc.

Listed by Warnock Hersey and Guardian Fire Testing Laboratories Inc.

Refer to the Material Safety Data Sheet and product label prior to using this product. The Material Safety Data Sheet is available by calling (800) 922-5922 or on the Web at www.jm.com/roofing. For technical assistance, please call (800) 445-1500.

Downloads available at www.inprocorp.com/fireline520.

Downloads available at www.inprocorp.com/fireline520.



EXPAND-O-GARD

Expansion joints are flexible waterproof closures for building walls designed to accommodate movement between building components caused by thermal expansion, settlement, wind and seismic forces.

Expand-O-Gard is a combination of a durable elastomeric bellows attached to two metal flanges, both mechanically and chemically, by a patented bifurcation process.

It is available in two designs, style WS and style F. Factory-fabricated transitions are available to accommodate intersections between vertical Expand-O-Gard and horizontal Expand-O-Flash expansion joints.

EXPANSION JOINTS



WS VERTICAL – CONCEALED FLANGES



F VERTICAL – SURFACE MOUNTED

STYLE

MATERIAL COMPATIBILITY
Please refer to the relevant JM specification sheets for details.

Masonry construction, metal buildings and panel wall systems where flanges are concealed within the wall system.

Joints between new and existing walls, between curtain walls and glass atriums, and other walls where the flange is exposed. Style F can be surface mounted.

FACTORY TRANSITIONS

Available to accommodate intersections between vertical Expand-O-Gard and horizontal Expand-O-Flash expansion joints.

Available to accommodate intersections between vertical Expand-O-Gard and horizontal Expand-O-Flash expansion joints.

BELLOWS MATERIALS

EPDM Black – Standard
White EPDM and Black Neoprene available upon request.

Neoprene Black – Standard
White EPDM and Black EPDM available upon request

FLANGE MATERIALS

Galvanized, 26 ga (0.55 mm)
Aluminum, 0.032" (0.81 mm)
Stainless Steel, 0.018" (0.46 mm)
Copper, 16 oz (453.59 g)
Available with punched flanges (3/4") (1.91 cm) holes at 4" (10.16 cm) o.c. for masonry construction or unpunched.

Stainless Steel, 0.018" (0.46 mm)
Available with punched flanges (1/4") (6.35 cm) holes at 12" (30.48 cm) o.c. or for masonry or unpunched with one end of flange offset to provide 4" (10.16 cm) shiplap splice condition. Other metal flanges are available upon request.

AVAILABLE COATINGS

Freedom Gray Copper™ or Kynar®-colored finish upon request

BELLOWS SIZES*
Standard

4" (102 mm)
6" (152 mm)
8" (203 mm)
10" (254 mm)
12" (305 mm)

Joint Opening (span)

1"-2 3/8" (25 mm-67 mm)
2 3/4" - 4" (70 mm-102 mm)
4 1/8" - 5 1/4" (105 mm-133 mm)
5 3/8" - 6 3/8" (136 mm-168 mm)
6 3/4" - 8" (171 mm-152 mm)

Made-to-order

Larger bellows sizes available upon request.

Joint Opening (span)

1"-2 3/8" (25 mm-67 mm)
2 3/4" - 4" (70 mm-102 mm)
4 1/8" - 5 1/4" (105 mm-133 mm)
5 3/8" - 6 3/8" (136 mm-168 mm)
6 3/4" - 8" (171 mm-152 mm)

Larger bellows sizes available upon request.

FLANGES

4"

2 1/4" (5.72 cm) folded

LENGTHS

10' (3.05 m) – Bellows Sizes 4" to 12"
50' (15.24 m) – Bellows Sizes 4" to 8" (10.16 cm to 20.32 cm) only
100' (30.48 m) – Bellows Sizes 4" to 8" (10.16 cm to 20.32 cm) only
Custom lengths available upon request.
Copper or stainless steel flanges are recommended where contact with masonry is part of the design.

10' 4" (3.15 m) (*10' of yield. 4" shingles over next flange)

CONSIDERATIONS

Refer to the Material Safety Data Sheet and product label prior to using this product. The Material Safety Data Sheet is available by calling (800) 922-5922 or on the Web at www.jm.com/roofing. For technical assistance, please call (800) 445-1500.

*Based on a rule-of-thumb method for determining bellows widths for vertical styles:
 $1.5 \times (\text{the width of the joint}) = \text{Bellows Width}$
Always round up to next even number and, in all cases, anticipated movement should be considered for proper sizing.

Stainless is the metal of choice where staining is a concern.

*Based on a rule-of-thumb method for determining bellows widths for vertical styles:
 $1.5 \times (\text{the width of the joint}) = \text{Bellows Width}$
Always round up to next even number and, in all cases, anticipated movement should be considered for proper sizing.

STYLE WS USAGE DIAGRAMS

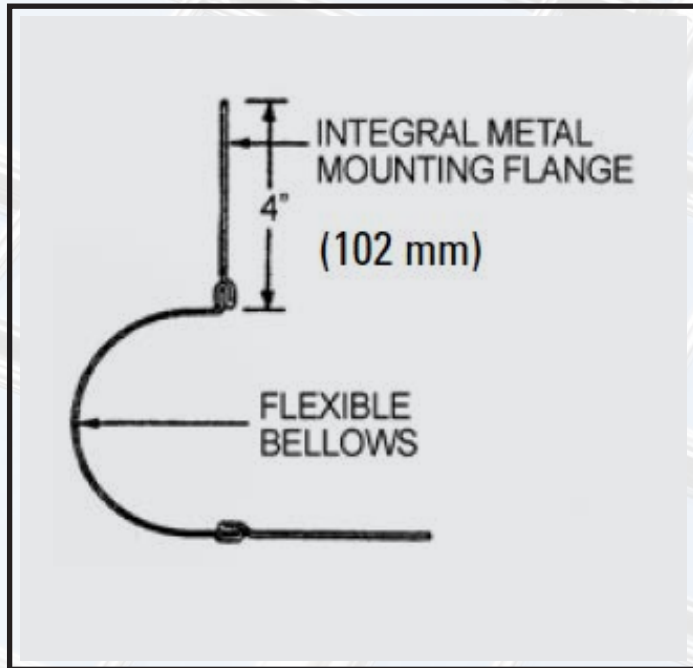

INSIDE CORNER CONDITION

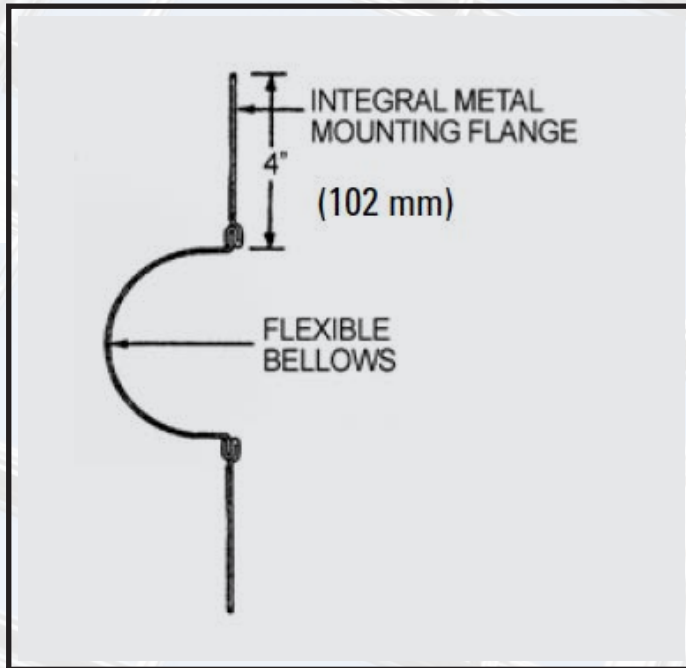

WALL-TO-WALL CONDITION

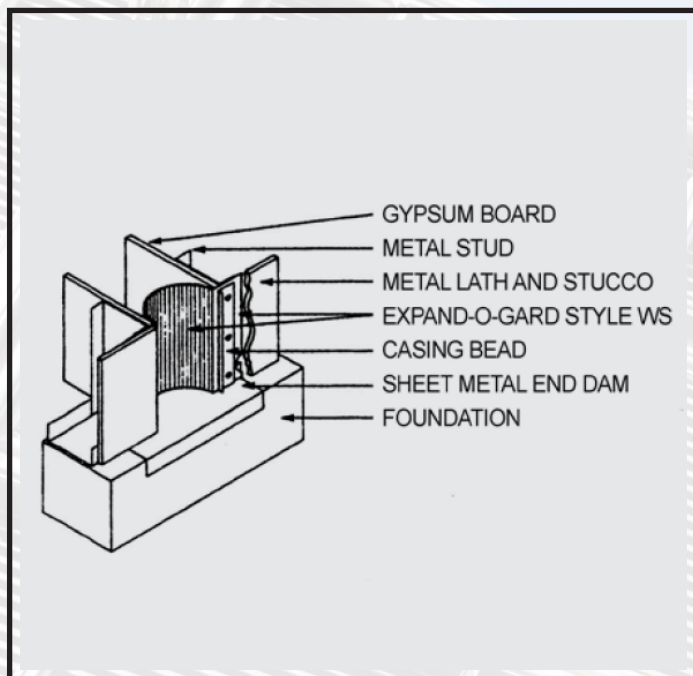

STYLE WS TERMINATION DETAIL

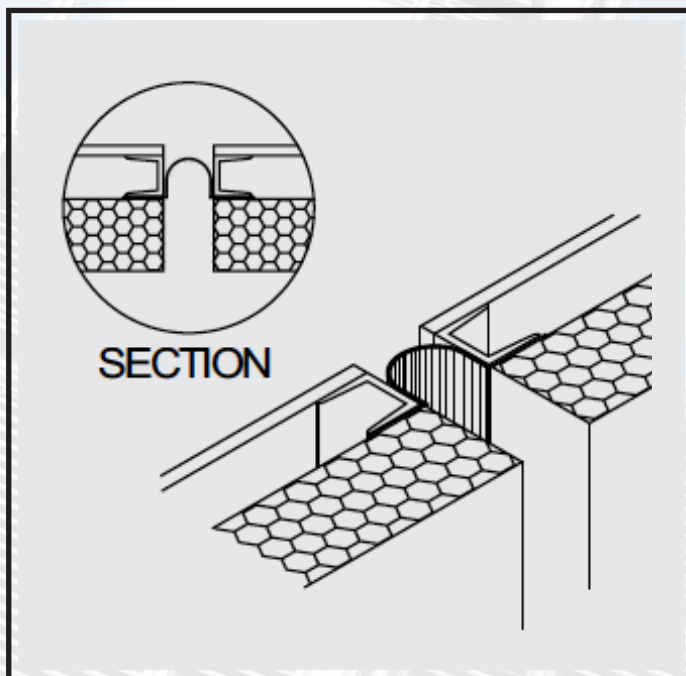

BEHIND EXTERIOR FACADE

STYLE F USAGE DIAGRAMS

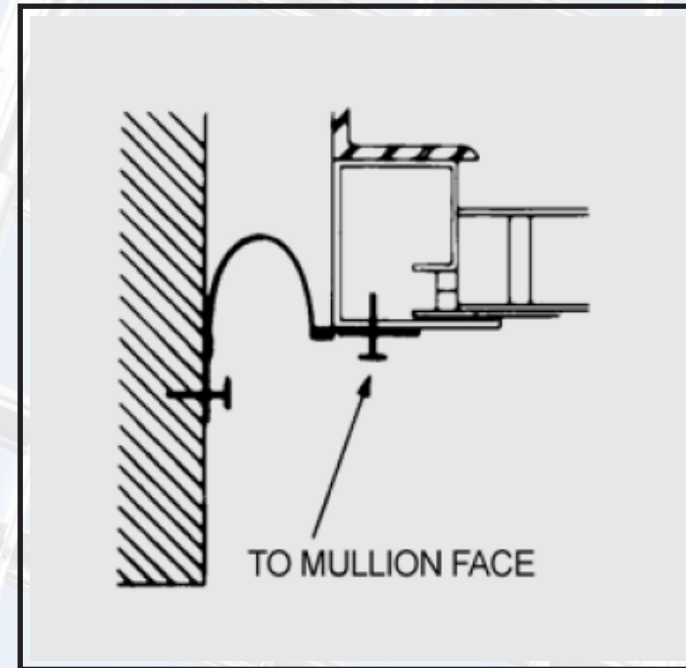

**CURTAIN-TO-WALL
DISSIMILAR MATERIAL (OPT 1)**

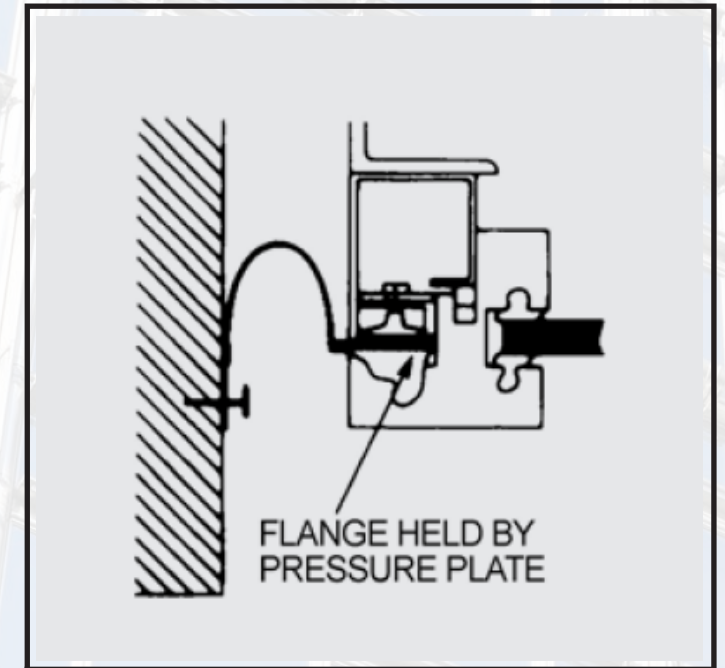

**CURTAIN-TO-WALL
DISSIMILAR MATERIAL (OPT 2)**

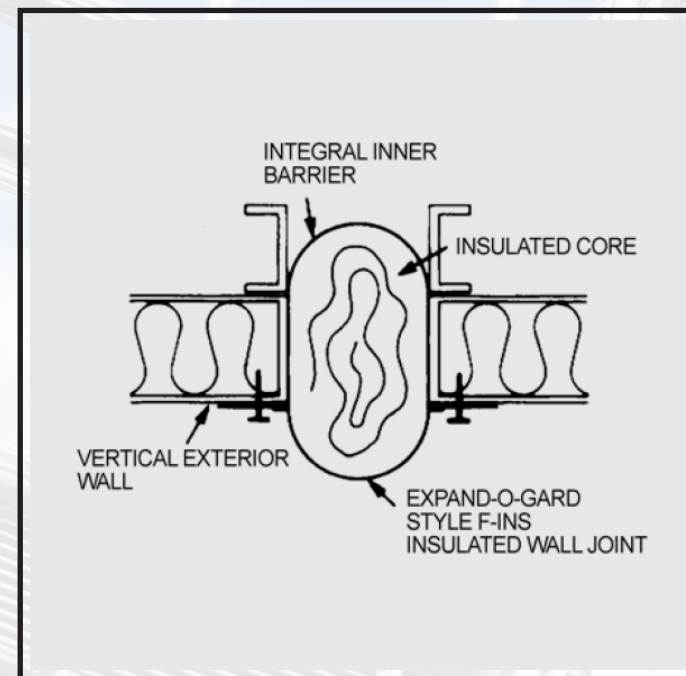

INSULATED WALL JOINT

EXPAND-O-GARD

For Styles WS & F

Specify when ordering

The Specialty Roofing Products group has established its expert reputation by offering custom designs and specially fabricated systems for building movement and closure problems.

No matter how challenging or unusual the design situation, JM can turn rough sketches into custom-manufactured systems.

These custom-designed systems can be included in the Johns Manville Peak Advantage Guarantee, one of the most comprehensive performance guarantees in the roofing industry. Here are a few examples of expansion joint transitions.

All styles are available with insulated bellows upon request.

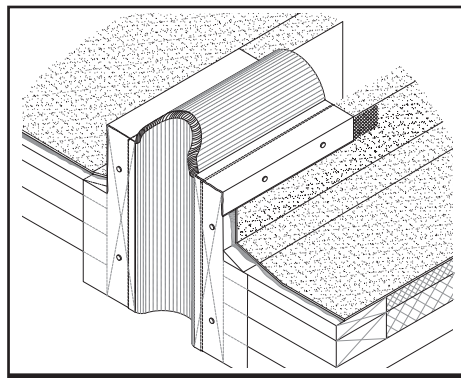

STYLE **CF EG-1**
TRANSITION RR VERTICAL OUTSIDE CORNER

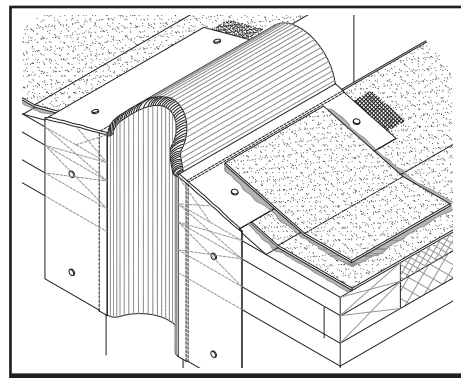

STYLE **EJ EG-11**
TRANSITION RR VERTICAL OUTSIDE CORNER

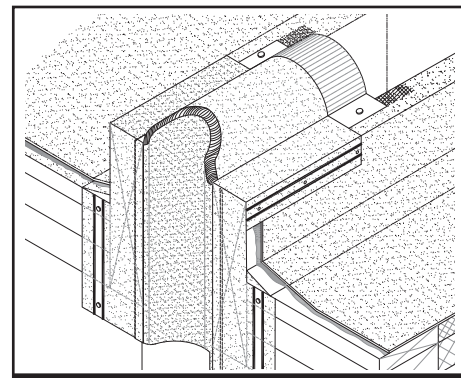

STYLE **EJ/WC EG-21**
TRANSITION RR VERTICAL OUTSIDE

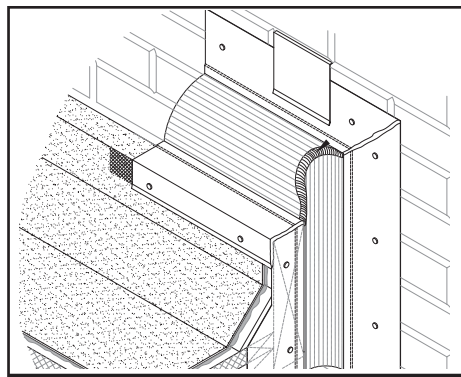

STYLE **CF/EJ EG-2**
TRANSITION RW VERTICAL OUTSIDE CORNER

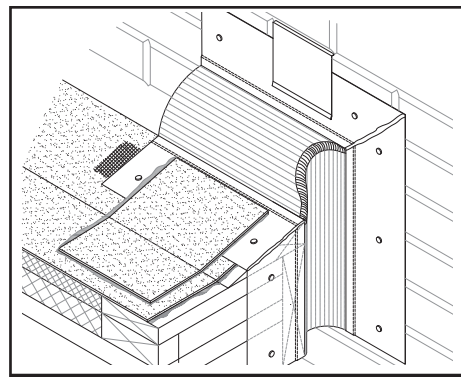

STYLE **EJ EG-12**
TRANSITION RW VERTICAL OUTSIDE CORNER

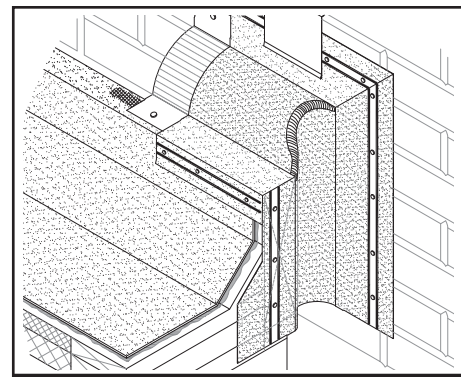

STYLE **EJ/WC EG-22**
TRANSITION RW VERTICAL OUTSIDE CORNER

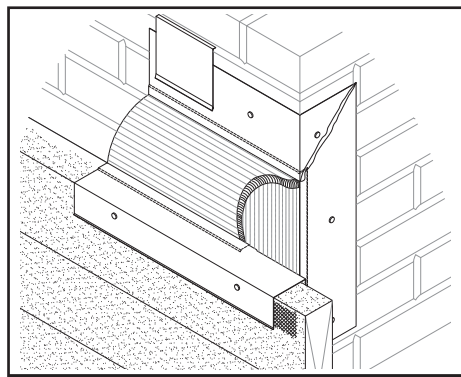

STYLE **CF/EJ EG-3**
TRANSITION RW VERTICAL OUTSIDE CORNER

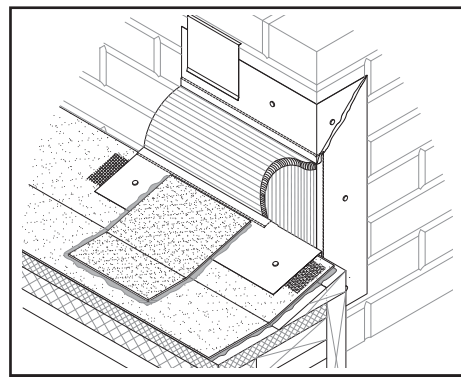

STYLE **EJ EG-13**
TRANSITION RW VERTICAL OUTSIDE CORNER

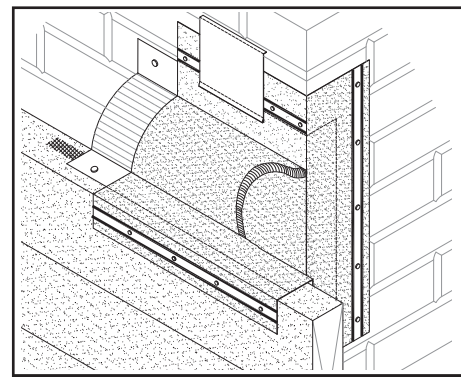

STYLE **EJ/WC EG-23**
TRANSITION RW VERTICAL OUTSIDE CORNER

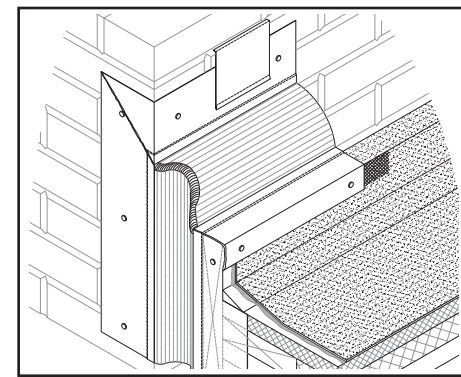

STYLE **CF/EJ EG-4**
TRANSITION RW VERTICAL OUTSIDE CORNER

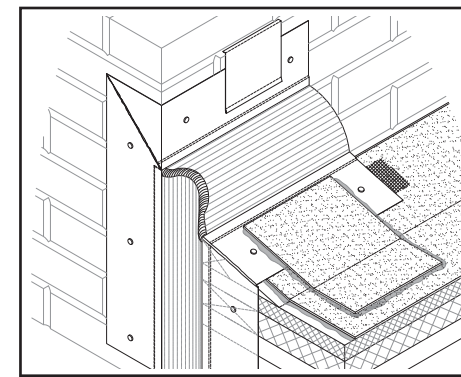

STYLE **EJ EG-14**
TRANSITION RW VERTICAL OUTSIDE CORNER

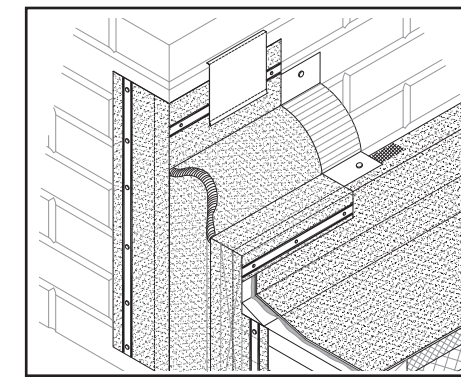

STYLE **EJ/WC EG-24**
TRANSITION RW VERTICAL OUTSIDE CORNER

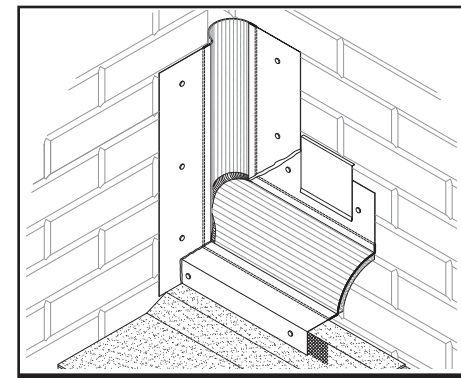

STYLE **CF/EJ EG-5**
TRANSITION RW VERTICAL INSIDE CORNER

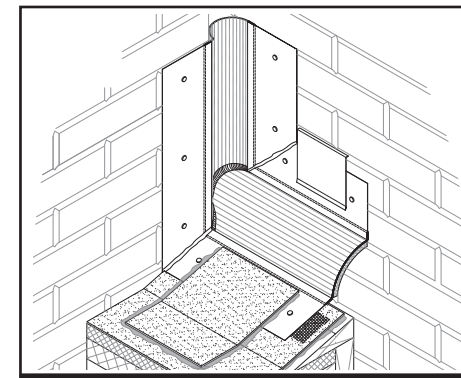

STYLE **EJ EG-15**
TRANSITION RW VERTICAL INSIDE CORNER

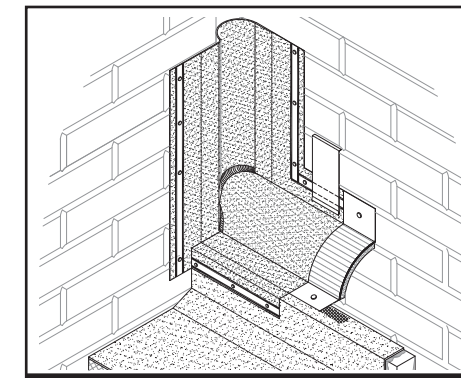

STYLE **EJ/WC EG-25**
TRANSITION RW VERTICAL INSIDE CORNER

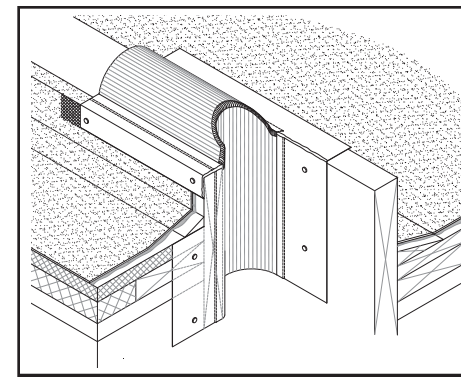

STYLE **CF EG-6**
TRANSITION RR VERTICAL OUTSIDE CORNER

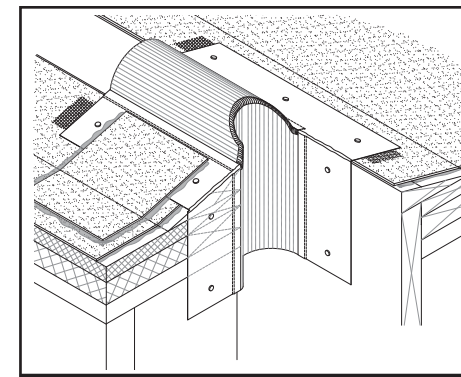

STYLE **EJ EG-16**
TRANSITION RR VERTICAL OUTSIDE CORNER

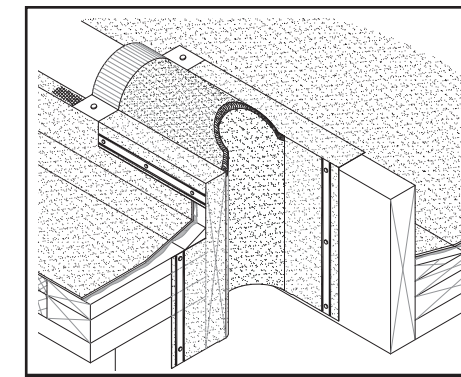

STYLE **EJ/WC EG-26**
TRANSITION RR VERTICAL OUTSIDE CORNER

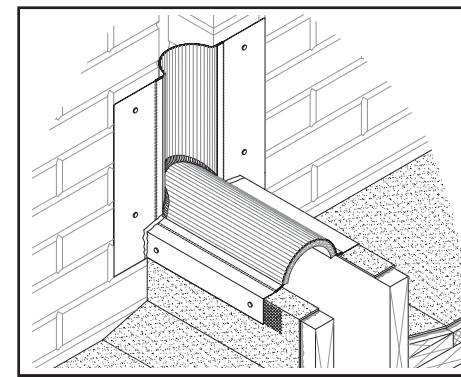

STYLE **CF EG-9**
TRANSITION RR VERTICAL INSIDE CORNER

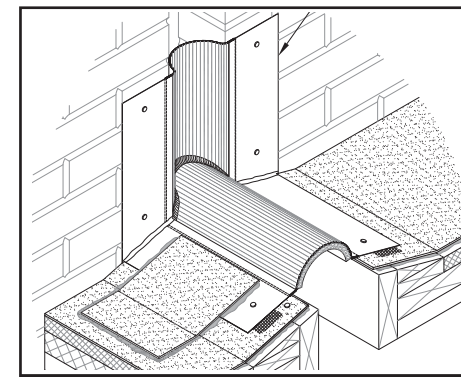

STYLE **EJ EG-19**
TRANSITION RR VERTICAL INSIDE CORNER

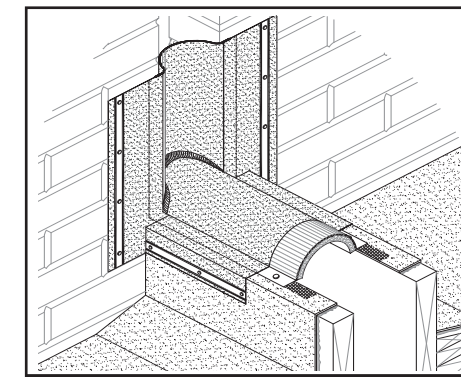

STYLE **EJ/WC EG-29**
TRANSITION RR VERTICAL INSIDE CORNER

EXPAND-O-GARD

For Styles WS & F

Specify when ordering

The Specialty Roofing Products group has established its expert reputation by offering custom designs and specially fabricated systems for building movement and closure problems.

No matter how challenging or unusual the design situation, JM can turn rough sketches into custom-manufactured systems.

These custom-designed systems can be included in the Johns Manville Peak Advantage Guarantee, one of the most comprehensive performance guarantees in the roofing industry. Here are a few examples of expansion joint transitions.

All styles are available with insulated bellows upon request.

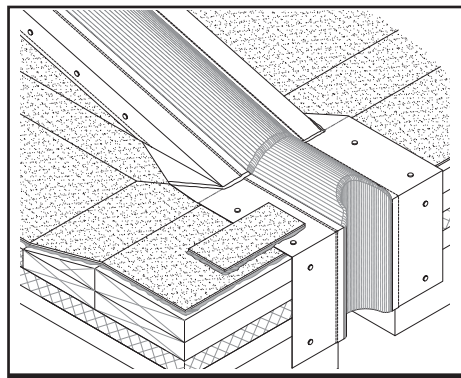

STYLE **CF/EJ FF-1**
TRANSITION **RR VERTICAL OUTSIDE CORNER**

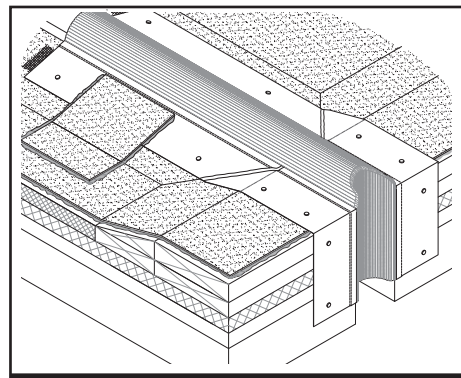

STYLE **EJ FF-11**
TRANSITION **RR VERTICAL OUTSIDE CORNER**

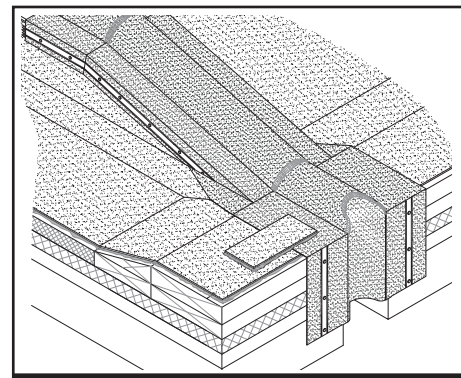

STYLE **EJ/WC FF-21**
TRANSITION **RR VERTICAL OUTSIDE CORNER**

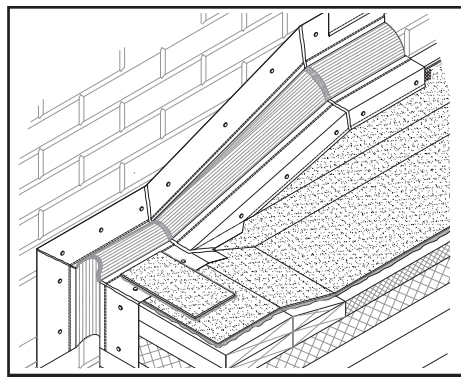

STYLE **CF/EJ FF-2**
TRANSITION **RW VERTICAL OUTSIDE CORNER**

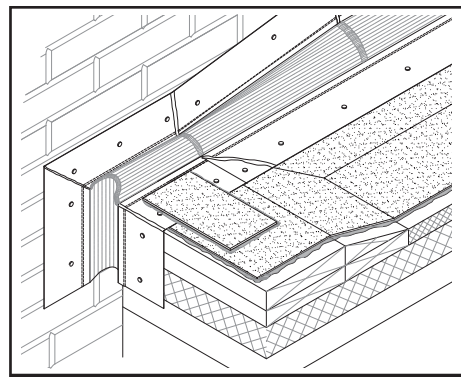

STYLE **EJ FF-12**
TRANSITION **RW VERTICAL OUTSIDE CORNER**

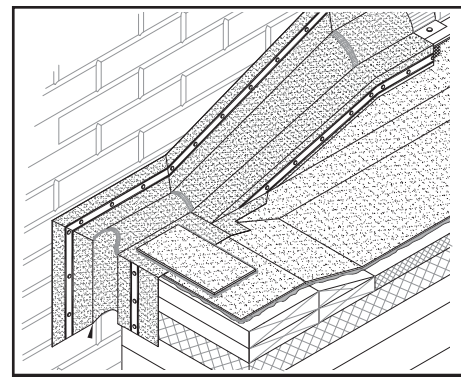

STYLE **EJ/WC FF-22**
TRANSITION **RW VERTICAL OUTSIDE CORNER**

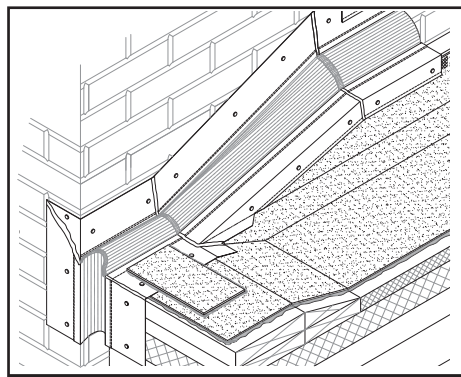

STYLE **CF/EJ FF-4**
TRANSITION **RW VERTICAL OUTSIDE CORNER**

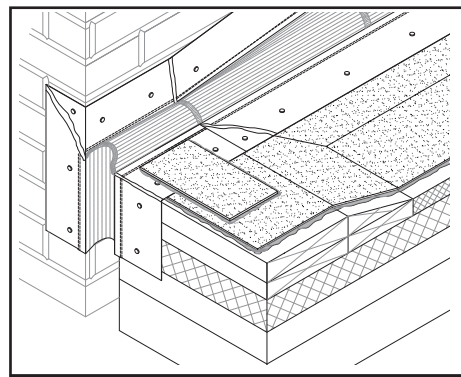

STYLE **EJ FF-14**
TRANSITION **RW VERTICAL OUTSIDE CORNER**

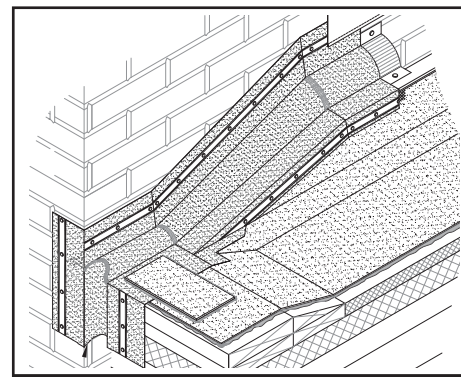

STYLE **EJ/WC FF-24**
TRANSITION **RW VERTICAL OUTSIDE CORNER**

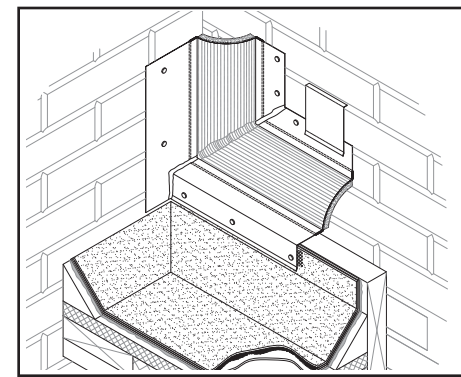

STYLE **CF/EJ PF-8**
TRANSITION **RW VERTICAL INSIDE CORNER**

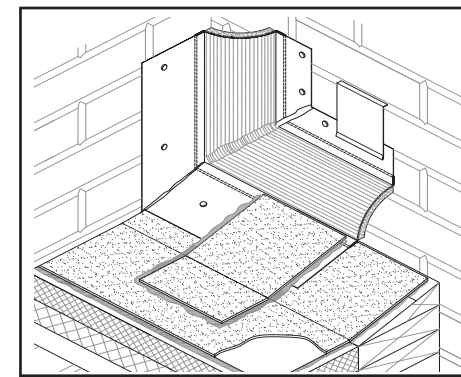

STYLE **EJ PF-18**
TRANSITION **RW VERTICAL INSIDE CORNER**

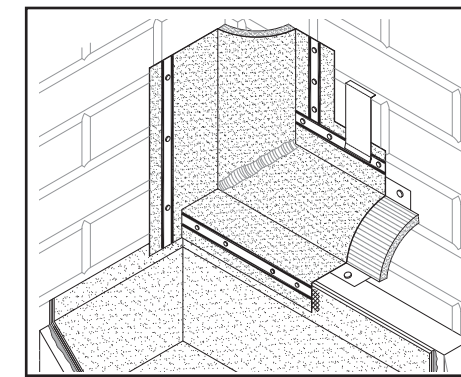

STYLE **EJ/WC PF-28**
TRANSITION **RW VERTICAL INSIDE CORNER**

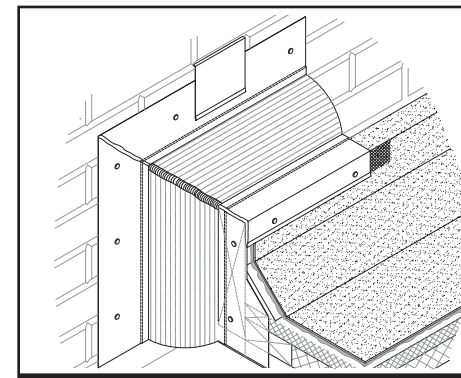

STYLE **CF/EJ EW-4**
TRANSITION **RW VERTICAL OUTSIDE CORNER**

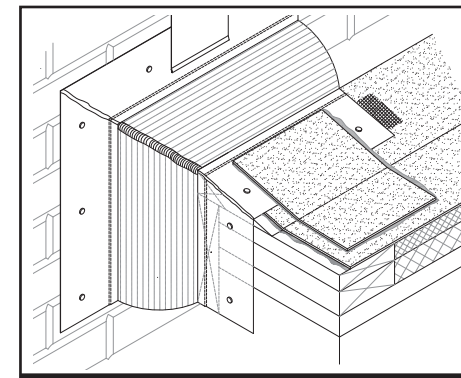

STYLE **EJ EW-14**
TRANSITION **RW VERTICAL OUTSIDE CORNER**

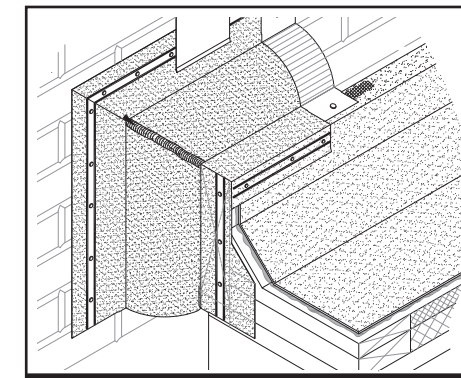

STYLE **EJ/WC EW-24**
TRANSITION **RW VERTICAL OUTSIDE CORNER**

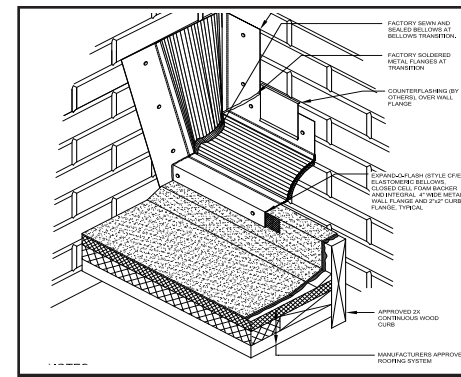

STYLE **EJ/WC EW-8 RAD**
TRANSITION **TERMINATION**

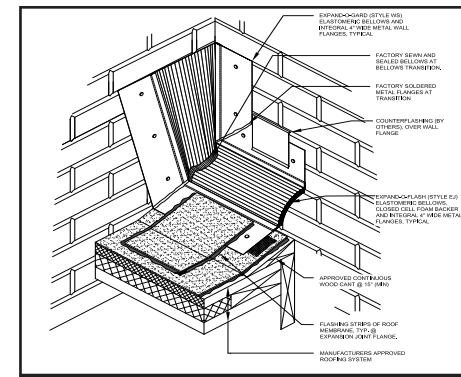

STYLE **EJ/WC EW-18 RAD**
TRANSITION **TERMINATION**

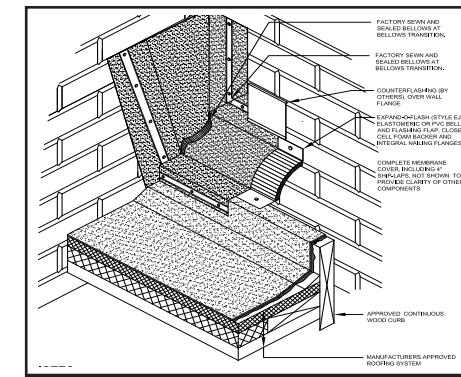

STYLE **EJ/WC EW-28 RAD**
TRANSITION **TERMINATION**

JM EPDM Metal/Membrane Flashing

A specially designed and manufactured flashing system for sealing and waterproofing adjacent JM EPDM and bituminous membrane roofing systems.

System construction:

- 6" (152 mm) strip of 60-mil (1.5 mm) cured EPDM
- 4" (102 mm) wide, 26-ga (0.5 mm) galvanized steel flange
- Secured to EPDM by a patented method
- Available in 100' (30.5 m) rolls

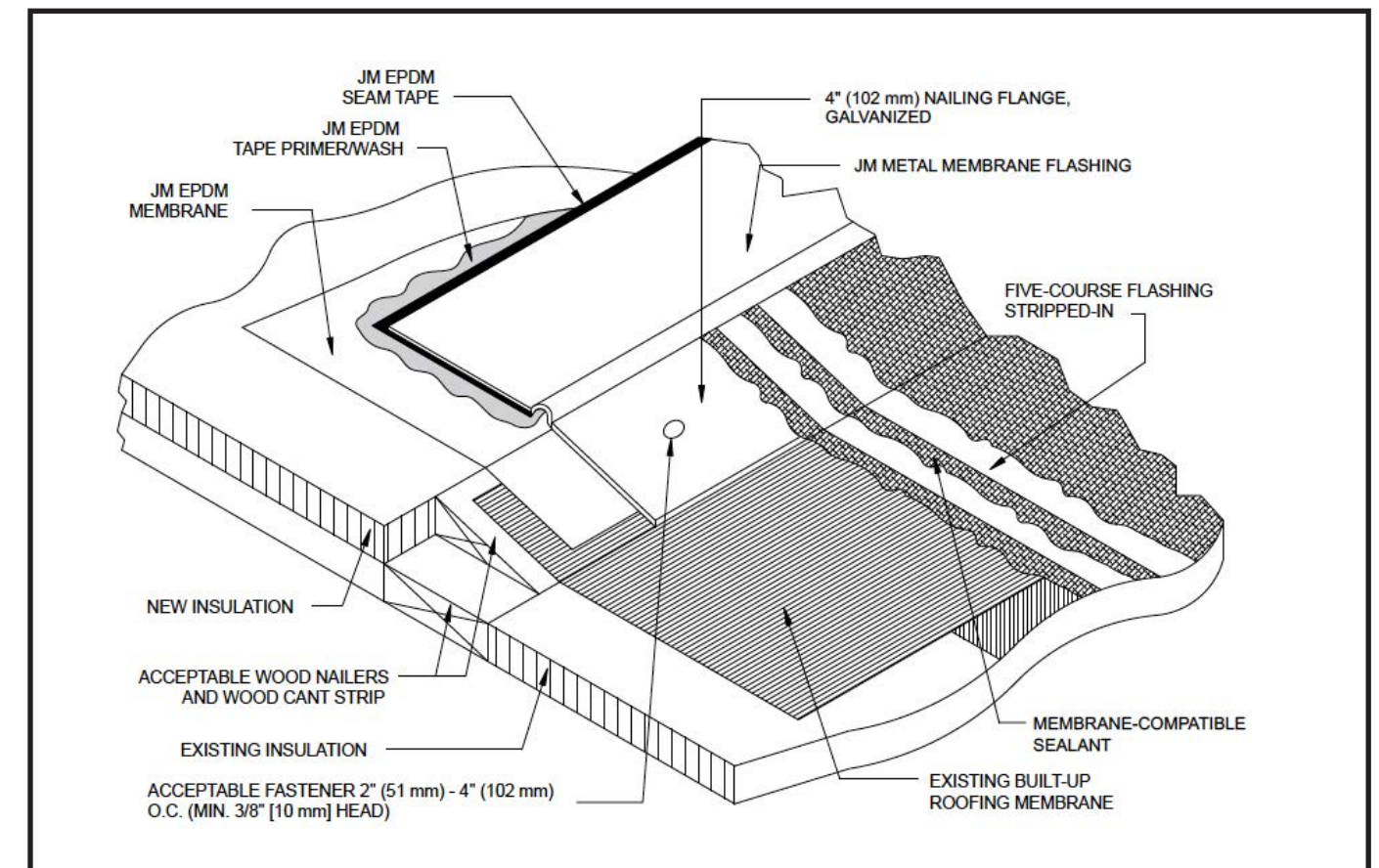



PRESTO LOCK AND PRESTO-TITE FASCIA SYSTEMS

ES-1 certified coping and fascia systems designed for fast snap-on assembly for use with single ply and bituminous roofing systems. They can be custom fabricated to fit exact requirements. Presto-Tite is specifically designed for maximum protection against wind uplift damage. All systems qualify for a JM Peak Advantage Guarantee.

EDGE METALS

STYLE



PRESTO-TITE FASCIA
(BITUMINOUS SYSTEMS)



PRESTO-TITE FASCIA
SINGLE PLY SYSTEMS

EDGE METALS

STYLE

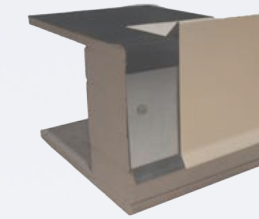

PRESTO STOP™ GRAVEL STOP

MEMBRANE COMPATIBILITY
Please refer to the relevant JM specification sheets for details.

MULTI-PLY: BUR APP SBS

SINGLE PLY: TPO PVC EPDM

MEMBRANE COMPATIBILITY
Please refer to the relevant JM specification sheets for details.

MULTI-PLY: BUR APP SBS
SINGLE PLY: TPO PVC EPDM

DESCRIPTION AND USES

A high-performance edge treatment for all modified bitumen and BUR roof projects. Also prevents the need to strip in the deck flange, eliminating potential delamination between the asphalt and metal deck flange due to thermal expansion and contraction forces. Provides maximum protection against wind uplift damage.

A high-performance edge treatment for fully adhered or mechanically fastened single ply roof projects. Also prevents the need to strip in the deck flange, eliminating potential delamination between the adhesive and roof flange due to thermal expansion and contraction forces. Provides maximum protection against wind uplift damage.

DESCRIPTION AND USES

Presto Stop is a factory-fabricated metal edge system used to terminate the roof at the perimeter of a structure. Presto Stop can be used with built-up, modified bitumen and single ply roofing systems. Presto Stop is an economical solution for many conditions, such as continuous edge drainage with or without a gutter.

ANCHOR BARS

12' (3.7 m) lengths, extruded 6063-T6 alloy aluminum, preslotted at 12" (30.48 cm) o.c.

GRAVEL STOP AND DRIP EDGE

10' (3.05 m) lengths formed from: 24 ga (0.61 mm) or 22 ga (0.76 mm) galvanized steel, or 0.040" (1.02 mm), 0.050" (1.27 mm) or 0.063" (1.6 mm) aluminum. Other metals are available upon request, including PVC-coated metal and TPO-coated metal.

FASTENERS

Stainless steel #9 x 2" (5.08 cm) fasteners with hexagonal head and driver bit are furnished. Masonry fasteners available upon request.

SNAP-ON FASCIA COVER

12' (3.7 m) lengths available in 24 ga. (0.6 mm) steel and 0.040" (1.02 mm) aluminum; other metals available upon request. Factory "notched" to provide a 1" (2.54 cm) lap joint.

ANCHOR BAR SPLICE PLATES

Provided compression gasket allows for thermal movement of the fascia systems.

ANCHOR CLEAT

Galvanized continuous anchor cleat is provided with all gravel stops.

ACCESSORIES

Factory-welded anchor bar corners, overflow and spillout scuppers, downspout sumps, radius and special angles, extenders and soffit clip systems are also available. Refer to the Material Safety Data Sheet and product label prior to using this product.

SIZES

10' (3.05 m) lengths, 2" (5.08 cm) to 10" (25.4 cm) fascia heights

SIZES

Style	Face Height	Coverage Dimension	Style	Face Height	Coverage Dimension
PFM-55	5.5" (140 mm)	4.25" (108 mm)	PF-40	4" (102 mm)	2.75" (70 mm)
PFM-70	7" (178 mm)	5.75" (146 mm)	PF-55	5.5" (140 mm)	4.25" (108 mm)
PFM-85	8.5" (216 mm)	7.25" (184 mm)	PF-70	7" (178 mm)	5.75" (146 mm)
			PF-85	8.5" (216 mm)	7.25" (184 mm)

GAUGES

Aluminum: 0.040" (1.02 mm), 0.050" (1.27 mm), 0.063" (1.6 mm)
Galvanized: 24 ga (0.61 mm), 22 ga (0.76 mm)

FINISHES

Steel and aluminum available in a number of standard Kynar® 500 colors; aluminum also available in mill and anodized finishes. Custom colors available upon request.

FINISHES

Aluminum: Mill, Kynar® 500, Clear or Colored Anodized
Galvanized: Mill and Kynar® 500

CODES

ES-1 certified designs available for most edge products.

EDGE METALS

STYLE



PRESTO LOCK FASCIA
SNAP-ON FASCIA SYSTEM

MEMBRANE COMPATIBILITY
Please refer to the specific JM specification sheets for details.

MULTI-PLY: BUR APP SBS
SINGLE PLY: TPO PVC EPDM

DESCRIPTION AND USES

The Presto Lock Fascia System is an economical snap-on fascia system designed for use with single ply, built-up and modified bitumen roofing systems. The fascia system consists of a galvanized or aluminum base piece (water dam) and galvanized steel or aluminum cover plate. Concealed cover plates complete the system.

WATER DAM

10' (3.05 m) sections of 24 gauge (0.61 mm) galvanized steel.

COVER PLATE

10' (3.05 m) sections snapped into place over the water dam. Available in two sizes and materials.

EXTENDER PLATE

For use where additional metal coverage is required. Fits behind the bottom edge of the fascia system and extends downward the required distance from 4" to 12" (30.48 cm to 35.56 cm) in 1" (2.54 cm) increments. Concealed extender plates are placed behind each joint.

ACCESSORIES

Inside and outside corners, fascia sumps and scuppers are available and made of the same material and color as the cover plate.

SIZES

10' (3.05 m) sections, standard face sizes are 7" (17.78 cm) and 9" (22.86 cm)

GAUGES

Aluminum gauges:
0.040" (1.02 mm), 0.050" (1.27 mm), 0.063" (1.6 mm)
Galvanized gauges: 22 gauge (0.76 mm) 24 gauge (0.61 mm)

FINISHES

Steel and aluminum available in a number of standard Kynar® 500 colors. Aluminum also available in mill and anodized finishes. Custom colors available upon request.

CODES

ES-1 certified designs available for most edge products.

EDGE METALS

STYLE

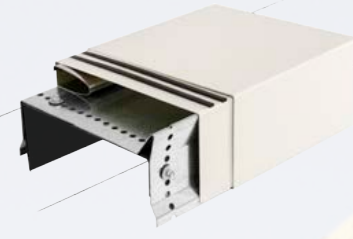

PRESTO LOCK COPING

MEMBRANE COMPATIBILITY
Please refer to the specific JM specification sheets for details.

MULTI-PLY: BUR APP SBS
SINGLE PLY: TPO PVC EPDM

DESCRIPTION AND USES

A cost-effective snap-on coping system designed for use with single ply, built-up and modified bitumen roofing systems. The system consists of galvanized steel anchor clips and aluminum or galvanized coping covers in a variety of thicknesses and colors.

ANCHOR CLIPS

12" wide galvanized steel base with stainless steel spring clip designed to keep upward pressure on the coping cover. Pre-punched for proper fastener location.

COVER PLATE

12' (3.7 m) lengths sections snapped into place over anchor clips.

CONCEALED SPLICE PLATE

8" (20.3 cm) wide plate, with metal and finish to match cover, and dual non-curing isocryl butyl sealant strips to allow for thermal movement and seals joints.

ACCESSORIES

Factory-fabricated miters, end caps and tees are available with "quicklock" or welded seams.

SIZES

12' (3.66 m) sections in many sizes to fit various field conditions.

GAUGES

Aluminum: 0.040" (1.02mm), 0.050" (1.27mm), 0.063" (1.6 mm)
Galvanized: 22 ga (0.76 mm) 24 ga (0.61 mm)

FINISHES

Steel and aluminum available in a number of standard Kynar® 500 colors. Aluminum also available in mill and anodized finishes. Custom colors available upon request.

CUSTOM CAPABILITIES

Quicklock and welded radius coping available along with other specially fabricated coping products to meet the needs of the project.



DRAINS AND VENTS

A variety of roof vents and drains allow for vapor pressure control and drainage, providing watertight seals between the roof, the drain and plumbing.

DRAINS AND VENTS

STYLE

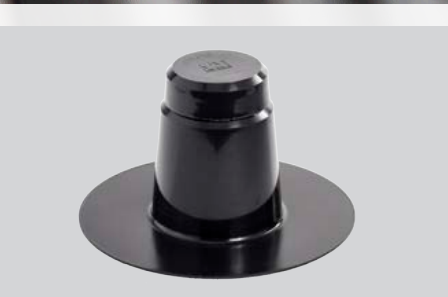

FP-10 ONE WAY ROOF VENT



FLEX-I-DRAIN®



PC/PET RETRODRAIN®



SUPERDOME® RETRODRAIN®

MEMBRANE COMPATIBILITY
Please refer to the specific JM specification sheets for details.

MULTI-PLY: BUR APP SBS

MULTI-PLY: BUR APP SBS
SINGLE PLY: TPO PVC EPDM

MULTI-PLY: BUR APP SBS
SINGLE PLY: TPO PVC EPDM

MULTI-PLY: BUR APP SBS
SINGLE PLY: TPO PVC EPDM

USES AND DESCRIPTION

Designed for use in bituminous roofing systems, the FP-10 One Way Roof Vent is a solar-operated, moisture/vapor venting unit designed to release and prevent the re-entry of moisture-laden air in new or existing lightweight fill decks and most low-slope industrial/commercial roofing systems.

Because of its unique flashing system, Flex-I-Drain is compatible with all roofing membrane systems and decks. Up to 3½" (8.89 cm) of insulation can be placed under the drain. Designed to connect to the building plumbing system with no hub connectors, the flexible bellows allow differential movement up to 1" (2.54 cm) in any direction between the roof deck/roofing system and the plumbing.

Manufactured with a tough copolymer resin that is compatible with any roofing system, RetroDrains® are designed to replace existing drains in re-roofing applications. PC/PET drains can even withstand the heat associated with torch down roofing applications.

Manufactured with a tough copolymer resin that is compatible with any roofing system, RetroDrains® are designed to replace existing drains in re-roofing applications. PC/PET drains can even withstand the heat associated with torch down roofing applications.

MATERIALS

Body and Flange: Polyethylene

Body: 8" (20.3 cm) length, neoprene flexible bellows body.
Flange: 11.25" (28.58 cm) diameter GE Noryl Resin.
Strainer Dome: 4" (10.16 cm) tall GE Noryl®* Resin dome.

Body and Flange: Seamless, manufactured from engineered PC/PET (Polycarbonate Polyethylene Terephthalate).
Strainer Dome: Available in 4" (10.16 cm) tall PC/PET

Body and Flange: Seamless, manufactured from engineered PC/PET (Polycarbonate Polyethylene Terephthalate).
Cast Aluminum SuperDome: A screw-down access lid secures the drainage system against vandals. 5.5" (13.97 cm) tall cast aluminum SuperDome with screw-down lid, to secure against vandals.

SIZES

TO FIT

N/A

3", 4", 5" and 6"
(76 mm, 102 mm, 127 mm and 152 mm)

3" and 4" (76 mm and 102 mm)

3" and 4" (76 mm and 102 mm)

BODY

4.5" (11.43 cm) base diameter, 6" (15.24 cm) height

N/A

N/A

N/A

FLANGE

10" (25.4 cm) diameter

17.5" (445 mm)

13.9" (35.31 cm)

13.9" (35.31 cm)

DRAIN STEM LENGTH

N/A

12" (305 mm)

12.35" (31.37 cm)

12.35" (31.37 cm)

STRAINER

N/A

Height: 4" (102 mm)

Height: 4" (102 mm)

Height: 4" (102 mm)

WEATHERPROOFING

Cap: Polyethylene

N/A

U-Flow® Mechanical Seal:** watertight connection to pipes.

U-Flow® Mechanical Seal:** watertight connection to pipes.

AVAILABLE COLORS

Black

Black

Black

Aluminum superdome

ADDITIONAL DETAILS

Silicone rubber valve

UV Stable

UV Stable

UV Stable

* Noryl® is a registered trademark of General Electric.

* RetroDrain®, SuperDome® and U-Flow® are registered trademarks of OMG Roofing Products.

** Watertight U-Flow® Mechanical Seal requires U-Flow screwdriver, sold separately.

DRAINS AND VENTS

STYLE



PVC ALUMAWELD® RETRODRAIN®



HEAVY-DUTY TPO RETRODRAIN®



HERCULES® RETRODRAIN®

MEMBRANE COMPATIBILITY

Please refer to the specific JM specification sheets for details.

SINGLE PLY: PVC

SINGLE PLY: TPO

MULTI-PLY: BUR APP SBS
SINGLE PLY: TPO PVC EPDM

USES AND DESCRIPTION

Designed for use in single ply PVC roof systems to replace existing drains in re-roofing applications. This one-piece, spun aluminum body has a plastisol-coated flange for direct hot-air welding of PVC roof membranes. The drain flange has a depressed sump area to facilitate the easy drainage of all water from the roof surface.

Designed for use in single ply TPO roof systems to replace existing drains in re-roofing applications. The one-piece spun aluminum body has a TPO-coated flange for direct hot-air welding to TPO roof membranes. The drain flange has a depressed sump area for improved flow and to facilitate drainage.

Designed to replace existing drains in all roofing systems. The one-piece spun aluminum body and heavy-duty cast aluminum dome and clamping ring provide strength and durability. The drain flange has a depressed sump area for improved flow and to facilitate water drainage from roof surface.

MATERIALS

Body: Spun aluminum
Flange: Plastisol-coated for direct hot-air welding of PVC roof membranes.

Body: Spun aluminum
Flange: TPO-coated flange, for direct hot-air welding to most TPO membranes.

Body: Spun aluminum
Flange: Extra large 17.5" (44.45 cm) diameter flange that allows positive attachment of roof flashing membrane.

SIZES

TO FIT

3", 4", 5" and 6" (76 mm, 102 mm, 127 mm and 152 mm)
Custom sizes available upon request.

3", 4", 5" and 6" (76 mm, 102 mm, 127 mm and 152 mm)
Custom sizes available upon request.

3", 4", 5" and 6" (76 mm, 102 mm, 127 mm and 152 mm)
Custom sizes available upon request.

BODY

0.125" (3 mm)

0.125" (3 mm)

0.125" (3 mm)

FLANGE

17.5" (44.45 cm)

17.5" (44.45 cm)

17.5" (44.45 cm)

DRAIN STEM LENGTH

12" (30.48 cm)

12" (30.48 cm)

12" (30.48 cm)

STRAINER

Height: 7" (17.78 cm)

Height: 7" (17.78 cm)

Height: 7" (17.78 cm) or 5.5" (14.0 cm)

WEATHERPROOFING

U-Flow® Mechanical Seal:** watertight connection to pipes.

U-Flow® Mechanical Seal:** watertight connection to pipes.

U-Flow® Mechanical Seal:** watertight connection to pipes.

AVAILABLE COLORS

Color: Aluminum

Color: Aluminum

Color: Aluminum

ADDITIONAL DETAILS

Heavy-duty cast aluminum strainer dome is easy to remove for cleaning.

Heavy-duty cast aluminum strainer dome is easy to remove for cleaning.

Available in two options: Standard or SuperDome with screw-down lid, to secure against vandals.

* PVC AlumaWeld®, Hercules®, RetroDrains® and U-Flow® are registered trademarks of OMG Roofing Products.

** Watertight U-Flow® Mechanical Seal requires U-Flow screwdriver, sold separately.

One Manufacturer.
One Easy Solution.
One Solid Guarantee.

And the technical support to get it right – the first time.

Technical Service (800) 445-1500

Customer Service (800) 223-8317

CONTACT US DIRECTLY



Specialty Roofing Products Team
roofacc@jm.com



Johns Manville offers the most comprehensive guarantee in the roofing industry. That's the advantage you can expect from a longtime, dependable leader along with the financial backing of Berkshire Hathaway.



Johns Manville

717 17th St.
Denver, CO 80202
(800) 922-5922
www.jm.com/roofing

Johns Manville