

## Design/System/Construction/Assembly Usage Disclaimer

- Authorities Having Jurisdiction should be consulted in all cases as to the particular requirements covering the installation and use of UL Certified products, equipment, system, devices, and materials.
  - Authorities Having Jurisdiction should be consulted before construction.
  - Fire resistance assemblies and products are developed by the design submitter and have been investigated by UL for compliance with applicable requirements. The published information cannot always address every construction nuance encountered in the field.
  - When field issues arise, it is recommended the first contact for assistance be the technical service staff provided by the product manufacturer noted for the design. Users of fire resistance assemblies are advised to consult the general Guide Information for each product category and each group of assemblies. The Guide Information includes specifics concerning alternate materials and alternate methods of construction.
  - Only products which bear UL's Mark are considered Certified.
- 

BXUV - Fire Resistance Ratings - ANSI/UL 263 Certified for United States

BXUV7 - Fire Resistance Ratings - CAN/ULC-S101 Certified for Canada

[See General Information for Fire-resistance Ratings - ANSI/UL 263 Certified for United States Design Criteria and Allowable Variances](#)

[See General Information for Fire Resistance Ratings - CAN/ULC-S101 Certified for Canada Design Criteria and Allowable Variances](#)

## Design No. **U366**

December 16, 2024

**Nonbearing Wall Rating - 2 Hr (Separation Wall, See Items 1, 2 and 3)**

**Bearing Wall Rating - 2 Hr (Protected Wall, See Items 4 and 4A)**

**Nonbearing Wall Rating - 2 Hr (Protected Wall, See Item 4B)**

**Finish Rating - 120 Min**

**\* Indicates such products shall bear the UL or cUL Certification Mark for jurisdictions employing the UL or cUL Certification (such as Canada), respectively.**

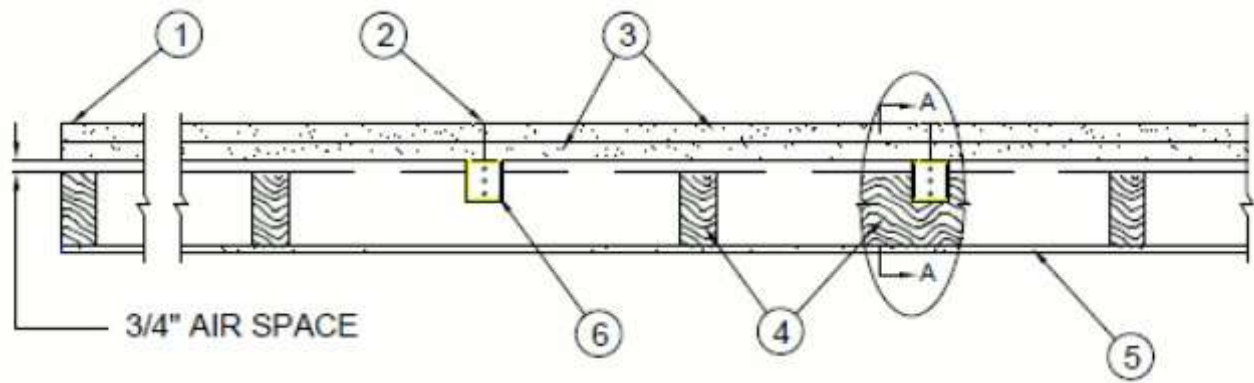

**CONFIGURATION A**  
EXPOSED TO FIRE FROM AREA SEPARATION WALL SIDE ONLY

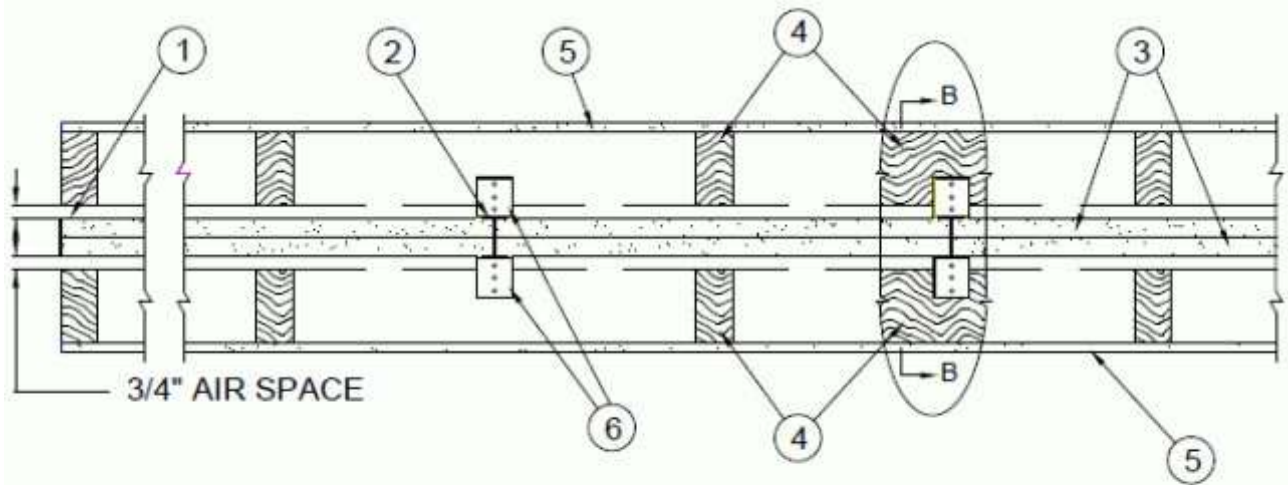

**CONFIGURATION B**  
EXPOSED TO FIRE FROM EITHER SIDE

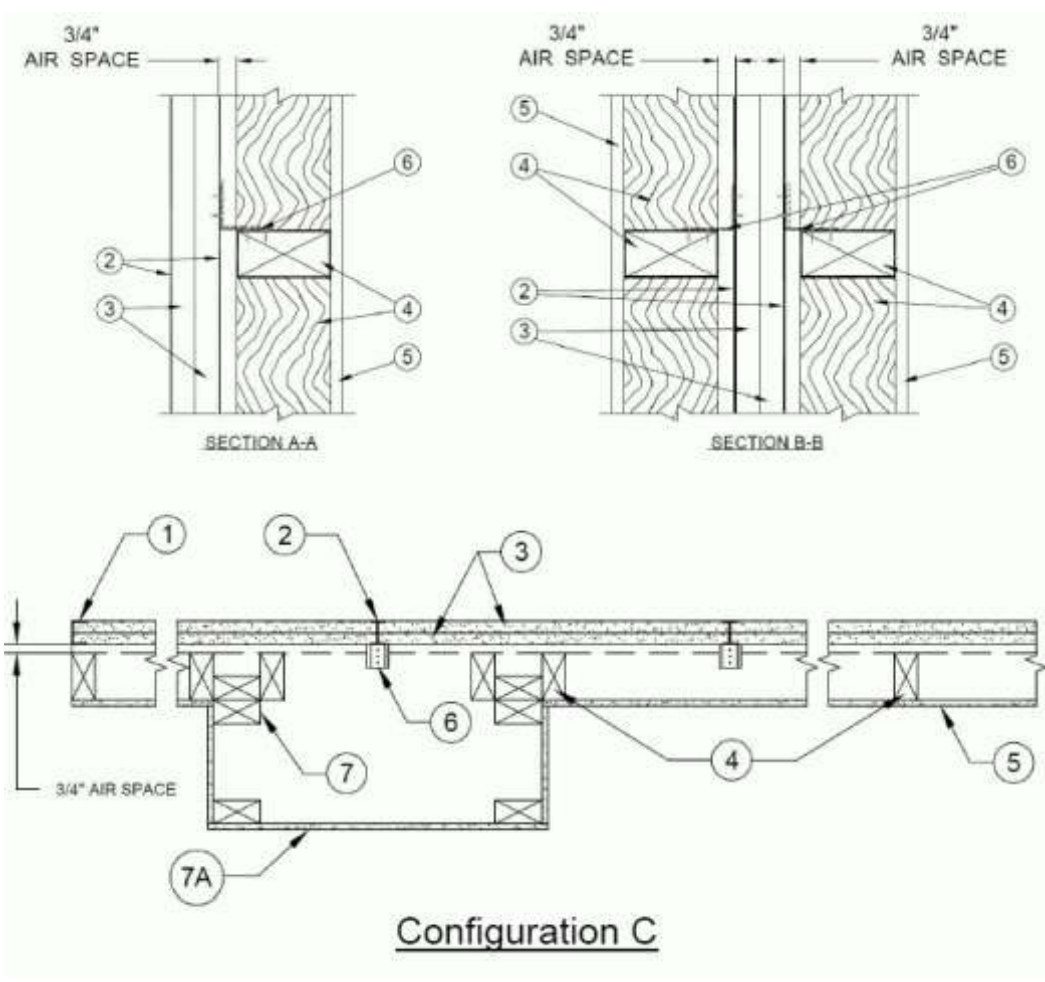

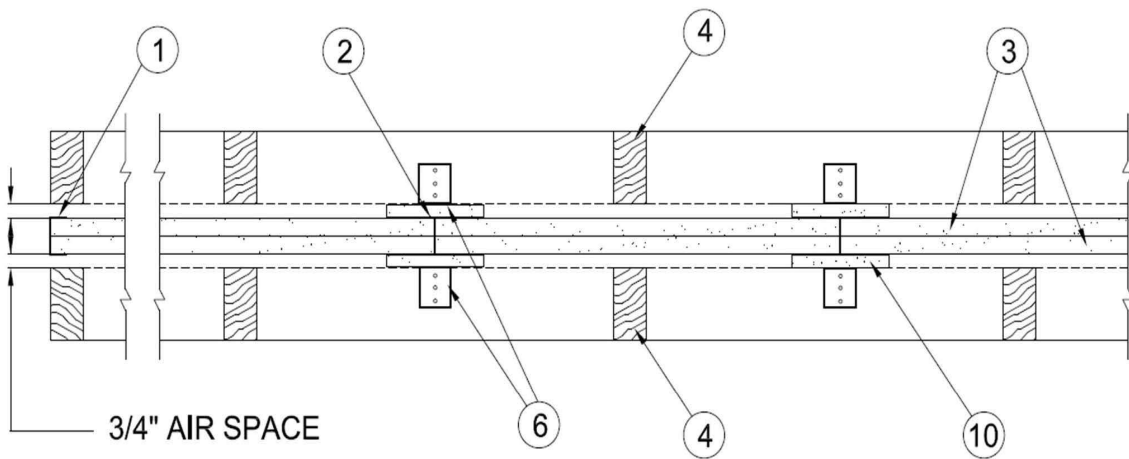
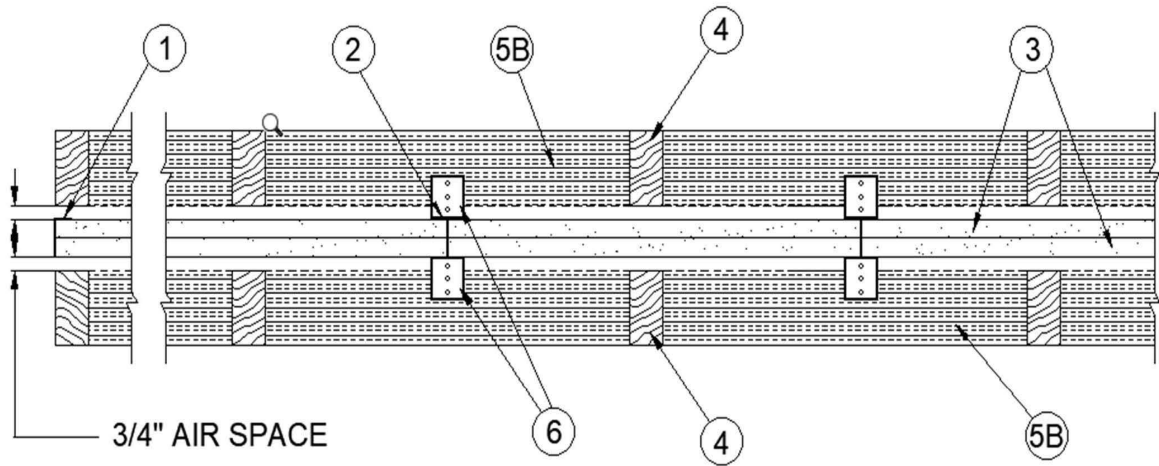

ALTERNATE CONFIGURATION D  
EXPOSED TO FIRE FROM EITHER SIDE

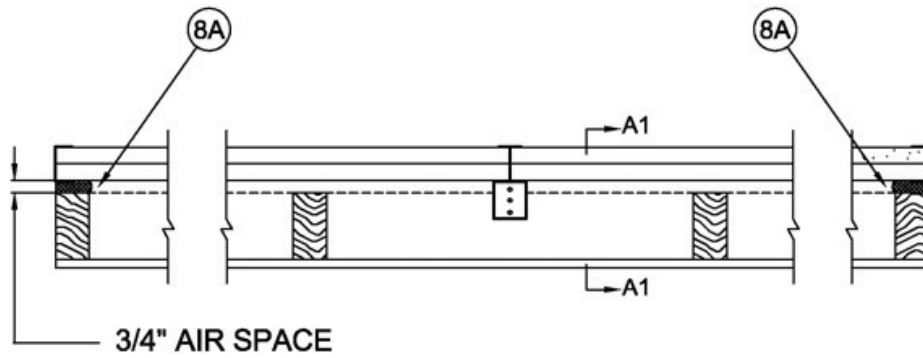

**CONFIGURATIONS A and C**  
EXPOSED TO FIRE FROM AREA SEPARATION WALL ONLY

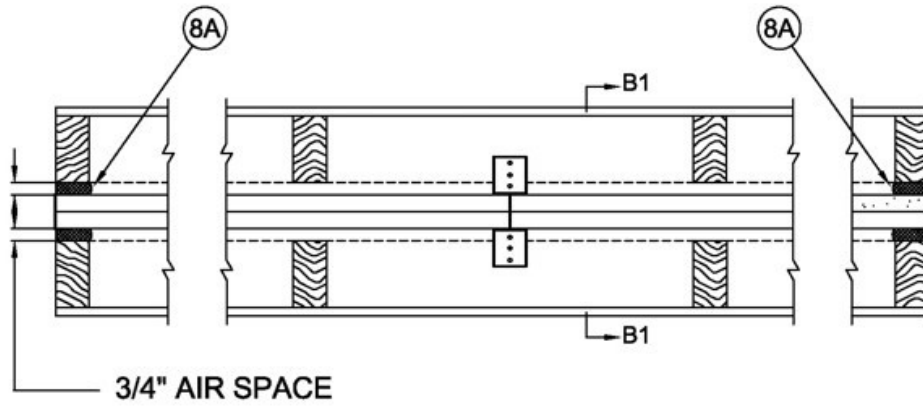

**CONFIGURATIONS B and D**  
EXPOSED TO FIRE FROM EITHER SIDE

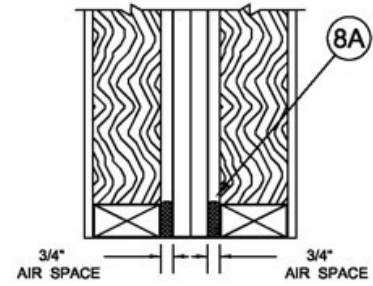
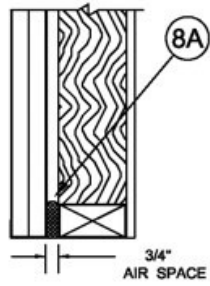
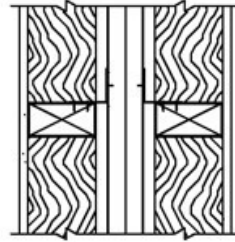
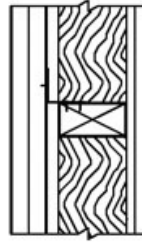
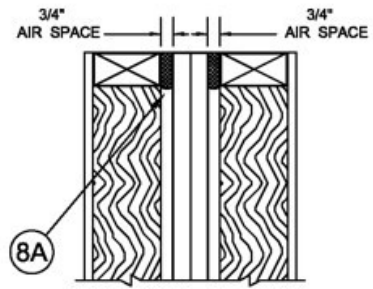
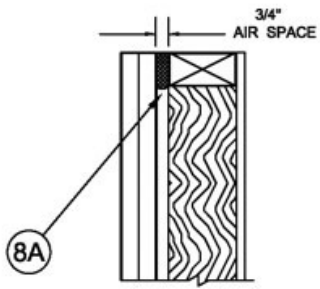

SECTION A1-A1

SECTION B1-B1

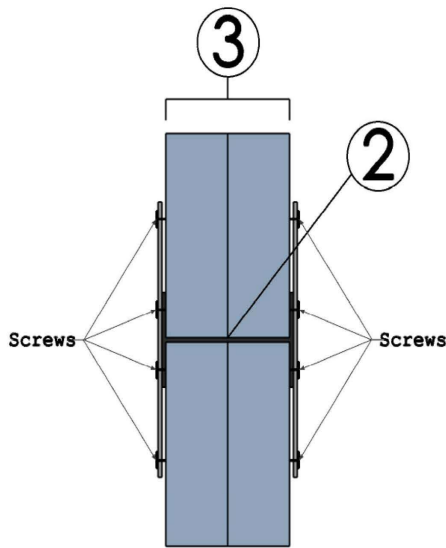

Min. 4", 25 ga. steel flat strap centered over horizontally installed H-stud on each side of wall, and secured at each vertical H-stud

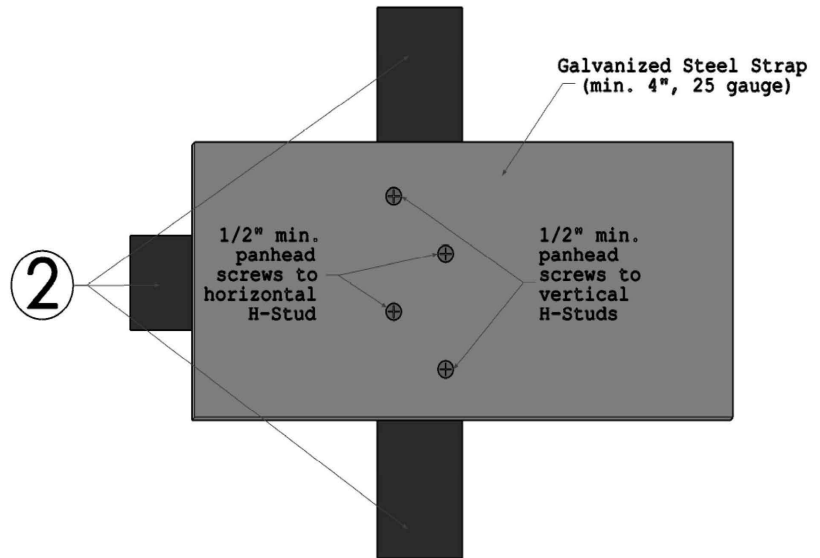

#### AREA SEPARATION WALL — (Max Height - 70 ft)

1. **Floor, Intermediate or Top Wall** — 2 in. wide channel shaped with 1 in. long legs formed from No. 25 MSG galv steel, secured with suitable fasteners spaced 24 in. OC.
2. **Steel Studs** — Steel members formed from No. 25 MSG galv steel having "H" - shaped flanged spaced 24 in. OC; overall depth 2 in. and flange width 1-3/8 in.
3. **Gypsum Board\*** — Two layers of 1 in. thick gypsum wallboard liner panels, supplied in nom 24 in. widths. Vertical edges of panels friction fitted into "H" - shaped studs.

**CERTAINTED GYPSUM INC** — Type Shaftliner, EGRG Shaftliner, GlasRoc Shaftliner, LGFCSL

**THAI GYPSUM PRODUCTS PCL** — Type Shaftliner

**PROTECTED WALL:** (Bearing or Nonbearing Wall. When Bearing, Load Restricted for Canadian Applications — See Guide [BXUV7](#).)

4. **Wood Studs** — Nom 2 by 4 in. max spacing 24 in. OC. Studs cross-braced at midheight where necessary for clip attachment. Min 3/4 in. separation between wood framing and area separation wall. Studs oriented with either face perpendicular to liner panels.

**4A. Steel Studs** — (As an alternate to Item 4, Not Shown) — For Bearing Wall - Corrosion protected steel studs, min No. 20 MSG (0.0329 in., min bare metal thickness) steel or min 3- 1/2 in. wide, min No. 20 GSG (0.036 in. thick) galv steel or No. 20 MSG (0.033 in. thick) primed steel, cold formed, shall be designed in accordance with the current edition of the Specification for the Design of Cold-Formed Steel Structural Members by the American Iron and Steel Institute. All design details enhancing the structural integrity of the wall assembly, including the axial design load of the studs, shall be as specified by the steel stud designer and/or producer, and shall meet the requirements of all applicable local code agencies. The max stud spacing of wall assemblies shall not exceed 24 in. OC. Studs attached to floor and ceiling tracks with 1/2 in. long Type S-12 steel screws on both sides of studs or by welded or bolted connections designed in accordance with the AISI specifications. Top and bottom tracks shall consist of steel members, min No. 20 MSG (0.0329 in., min bare metal thickness) steel or min No. 20 GSG (0.036 in. thick) galv steel or No. 20 MSG (0.033 in. thick) primed steel, that provide a sound structural connection between steel studs, and to adjacent assemblies such as a floor, ceiling, and/or other walls. Attached to floor and ceiling assemblies with steel fasteners spaced not greater than 24 in. O.C. Studs cross-braced with stud framing at midheight where necessary for clip attachment. Min 3/4 in. separation between steel framing and area separation wall. Finish rating has not been evaluated for Steel Studs.

**4B. Steel Studs** — (As an alternate to Items 4 and 4A) — For Nonbearing Wall — Channel shaped, fabricated from min 25 MSG corrosion-protected steel, min 3-1/2 in. wide, min 1-1/4 in. flanges and 1/4 in. return, spaced a max of 24 in. OC. Studs to be cut 3/8 to 3/4 in. less than assembly height. Top and bottom tracks shall be channel shaped, fabricated from min 25 MSG corrosion-protected steel, min width to accommodate stud size, with min 1 in. long legs, attached to floor and ceiling with fasteners 24 in. OC max. Studs cross-braced with stud framing at midheight where necessary for clip attachment. Min 3/4 in. separation between steel framing and area separation wall. Finish rating has not been evaluated for Steel Studs.

**5. Gypsum Board** — Classified or Unclassified — Min 1/2 in thick, 4 ft wide, applied either horizontally or vertically. Wallboard attached to studs with 1-1/4 in. long steel drywall nails or screws space 8 in. OC. Vertical joints located over studs. (Optional) Joints covered with paper tape and joint compound. Nail heads covered with joint compound. Wallboard attached to steel studs (Items 4A or 4B) with 1 in. long Type S steel screws spaced 12 in. OC. Vertical joints located over studs. Horizontal joints shall be butted tight to form a closed joint. As an option, joints covered with paper tape and joint compound. As an option, screw heads covered with joint compound.

**5A. Plywood Sheathing or OSB** — (Not Shown) — As an alternate to Items 5, 5B, and 5C. Nominal 1/2 in. thick or greater plywood or OSB applied horizontally or vertically to wood or steel studs. Vertical joints located over studs. Horizontal joints shall be butted tight to form a closed joint. Fastened to studs with nails or screws of sufficient length, spaced 12 in. OC. Joints and fastener heads are not required to be treated. Aluminum clips shall be spaced as described in Item 6.

**5B. Batts and Blankets\*** — As an alternate to Items 5 and 5A. Glass fiber or mineral wool insulation, min. 3-1/2 in. thick, placed to completely fill the wood or steel stud cavities. See Batts and Blankets (BKNV) category in the Building Materials Directory and Batts and Blankets (BZJZ) category in the Fire Resistance Directory for name of Classified Companies.

**5C. Wall and Partition Facings and Accessories\*** — (Not Shown) — As an alternate to Items 5, 5A, 5B and 5C. 4 ft wide panels, applied vertically. Panels attached to wood studs (Item 4) with 1-5/8 in. long steel drywall screws spaced 16 in. OC. Vertical joints located over studs. Joints covered with paper tape and joint compound. As an option, screw heads covered with joint compound.  
**CERTAINTED GYPSUM INC** — Type SilentFX

**5D. Wall and Partition Facings and Accessories\*** — (Not Shown) — Adhered stone veneer is mortar bonded to a lath and scratch coat applied to sheathing (Items 5, 5A, or 5C), installed in accordance with the manufacturers installation instructions, and meeting the requirements of local code agencies.

**ELDORADO STONE OPERATIONS L L C** — Type Eldorado Stone

**5E. Batts and Blankets\*** — (Not Shown, Optional) Used in addition to Items 5, 5A, or 5C. Placed in stud cavities, any glass fiber or mineral wool insulation, max 3.0 pcf density, bearing the UL Classification Marking as to Surface Burning Characteristics and/or Fire Resistance. See Batts and Blankets (BKNV or BZJZ) Categories for names of Classified companies.

**6. Attachment Clips** — Aluminum angle, 0.063 in. thick, min 2 in. wide with min 2 in. and 2-1/4 in. legs. Clips secured with Type S screws 3/8 in. long to "H" studs and with Type W screws 1-1/4 in. long to wood framing through holes provided in clip. Clips spaced a



max of 10 ft OC vertically between wood framing and "H" studs for separation walls up to 23 ft high. For separation walls up to 70 ft high, clips spaced as described above for the upper 24 ft. and the remaining wall area below requires clips spaced a max 5 ft OC vertically between wood framing and "H" studs.

**7. Non-Bearing Wall Partition Intersection** — (Optional) — Two nominal 2 by 4 in. stud or nominal 2 by 6 in. stud nailed together with two 3in. long 10d nails spaced a max. 16 in. OC. vertically and fastened to one side of the minimum 2 by 4 in. stud with 3 in. long 10d nails spaced a max 16 in. OC. vertically. Intersection between partition wood studs to be flush with the 2 by 4 in. studs. The wall partition wood studs are to be framed with a second 2 by 4 in. wood stud fastened with 3 in. long 10d nails spaced a max. 16 in. OC. vertically. Maximum one non-bearing wall partition intersection per stud cavity. Non-bearing wall partition stud depth shall be at a minimum equal to the depth of the wall.

**7A. Non-Bearing Wall Partition Intersection** — (Optional, Not Shown) — Nominal 2 by 4 in. or 2 by 6 in. wood studs intersecting protected wall cavity on each side of full width 24 in. cavity. Protected wall gypsum board min 1/2 in. thick, 4 ft wide, applied horizontally or vertically and perpendicular to Area Separation Wall. Wallboard attached to wood studs (Item 4) with 1-1/4 in. long steel drywall screws spaced 8 in. OC. Wood studs with gypsum board forms box coming out from Area Separation Wall. Max of one box constructed in alternating cavities.

**8. Caulk/Sealant** — (Optional, Not Shown, Intended for use as an air barrier - Not evaluated as fireblocking) — ASTM C834, Type OP, Grade 0° C or -18° C Latex Sealant at the Shaftliner and C-Track (Item 1) and H-Stud (Item 2) framing locations.

**8A. Caulking and Sealants\*** — (Optional - Intended for use as an air barrier - Not evaluated as fireblocking) - A bead of sealant applied around the partition perimeter in the 3/4 in. air space between wood framing (Item 4) and shaftliner panels (Item 3) to create an air barrier.

**DUPONT DE NEMOURS, INC.** — Great Stuff Gaps & Cracks, Great Stuff Pro Gaps & Cracks, Great Stuff Pro Window & Door

**ICP CONSTRUCTION INC** — Fireblock, Window & Door, Insulating Foam Sealant, Multi-Purpose, HC Sealants, Black Foam Sealant, Extreme, Window & Door Extreme, Fast Foam, Gun Foam, and Straw Foam

**9. Plywood Sheathing or OSB** — (Optional, Not shown) — Min 1/2 in. thick plywood or OSB applied horizontally or vertically to "H" studs on area separation wall side (Item 3) of Configuration A or Configuration D. Vertical joints located over studs. Fastened to "H" studs with screws of sufficient length, spaced a maximum of 12 in. OC.

**10. Gypsum Board\*** — As an alternate to Item 5 - Min 5/8 in. thick, min. 6 in. wide batten strips, applied on both sides of Steel Studs (Item 2). Min. 5/8 in. thick, min. 3 in. wide batten strips applied on both sides of single top and bottom track (Item 1) and at perimeter of assembly. Batten strips secured to studs with 1-1/4 in. long Type S steel screws spaced 12 in. OC. As an option, entire sheet of gypsum board may be used in lieu of the battens. Clip placement as in item 6. Issued: 2002-10-09

**CERTAINTED GYPSUM INC** — Type X-1

#### **Alternate Installation**

As an alternate construction method. When "H" studs, Item 2 are installed horizontally to cap the Area Separation Firewall In lieu of Item 1, construct as follows. (A) Secure a min. 4-inch-wide steel flat strap, fabricated from minimum 25-gauge galvanized steel, on each side of the horizontally installed "H" stud. (B) Ensure flat strap is centered over the "H" stud and attached with four 1/2 in. min long panhead screws on each side of the Area Separation Firewall. (C) Two screws are used to secure flat strap to vertical "H" stud, above and below the horizontal "H" stud. (D) Two screws are also inserted to secure flat strap to the horizontal "H" stud, in alternating pattern.

**\* Indicates such products shall bear the UL or cUL Certification Mark for jurisdictions employing the UL or cUL Certification (such as Canada), respectively.**

Last Updated on 2024-12-16

---

The appearance of a company's name or product in this database does not in itself assure that products so identified have been manufactured under UL Solutions' Follow - Up Service. Only those products bearing the UL Mark should be considered to be Certified and covered under UL Solutions' Follow - Up Service. Always look for the Mark on the product.

UL Solutions permits the reproduction of the material contained in Product iQ subject to the following conditions: 1. The Guide Information, Assemblies, Constructions, Designs, Systems, and/or Certifications (files) must be presented in their entirety and in a non-misleading manner, without any manipulation of the data (or drawings). 2. The statement "Reprinted from Product iQ with permission from UL Solutions" must appear adjacent to the extracted material. In addition, the reprinted material must include a copyright notice in the following format: "©2024 UL LLC."