

Design/System/Construction/Assembly Usage Disclaimer

- Authorities Having Jurisdiction should be consulted in all cases as to the particular requirements covering the installation and use of UL Certified products, equipment, system, devices, and materials.
 - Authorities Having Jurisdiction should be consulted before construction.
 - Fire resistance assemblies and products are developed by the design submitter and have been investigated by UL for compliance with applicable requirements. The published information cannot always address every construction nuance encountered in the field.
 - When field issues arise, it is recommended the first contact for assistance be the technical service staff provided by the product manufacturer noted for the design. Users of fire resistance assemblies are advised to consult the general Guide Information for each product category and each group of assemblies. The Guide Information includes specifics concerning alternate materials and alternate methods of construction.
 - Only products which bear UL's Mark are considered Certified.
-

BXUV - Fire Resistance Ratings - ANSI/UL 263 Certified for United States

BXUV7 - Fire Resistance Ratings - CAN/ULC-S101 Certified for Canada

[See General Information for Fire-resistance Ratings - ANSI/UL 263 Certified for United States Design Criteria and Allowable Variances](#)

[See General Information for Fire Resistance Ratings - CAN/ULC-S101 Certified for Canada Design Criteria and Allowable Variances](#)

Design No. **U373**

February 16, 2022

Nonbearing Wall Rating - 2 Hr (Area Separation Wall, See items 1, 2 and 3)

Bearing Wall Rating 2 Hr (Protected Wall, See Items 4, 4A and 4B)

Nonbearing Wall Rating 2 Hr (Protected Wall, See Item 4B)

Finish Rating - 120 Min (See Item 4)

*** Indicates such products shall bear the UL or cUL Certification Mark for jurisdictions employing the UL or cUL Certification (such as Canada), respectively.**

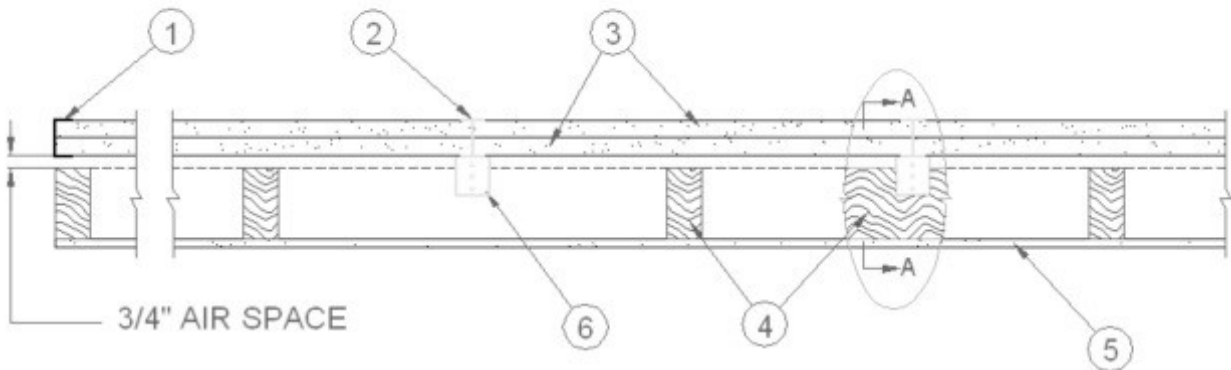
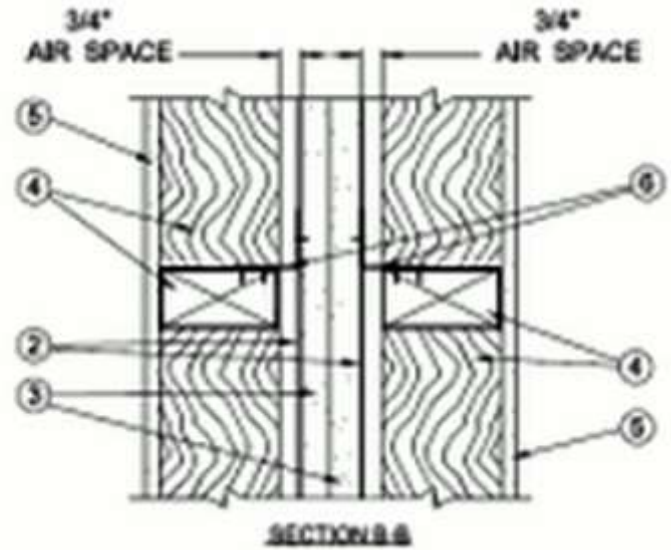
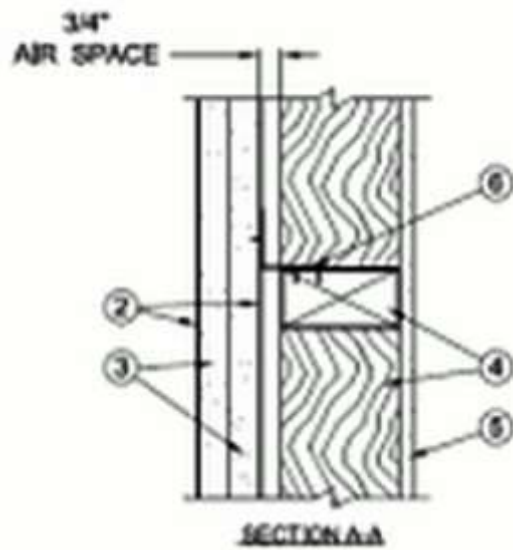

CONFIGURATION A
EXPOSED TO FIRE FROM AREA SEPARATION WALL SIDE ONLY

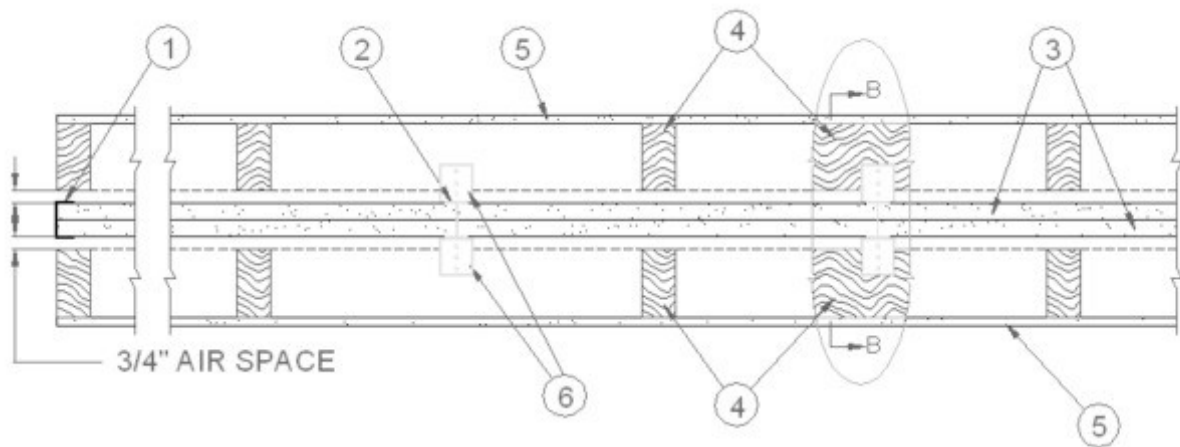

CONFIGURATION B
EXPOSED TO FIRE FROM EITHER SIDE

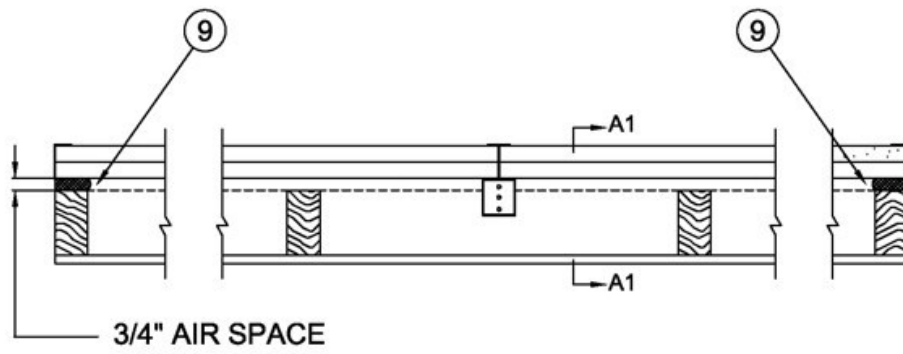

CONFIGURATION A
EXPOSED TO FIRE FROM AREA SEPARATION WALL ONLY

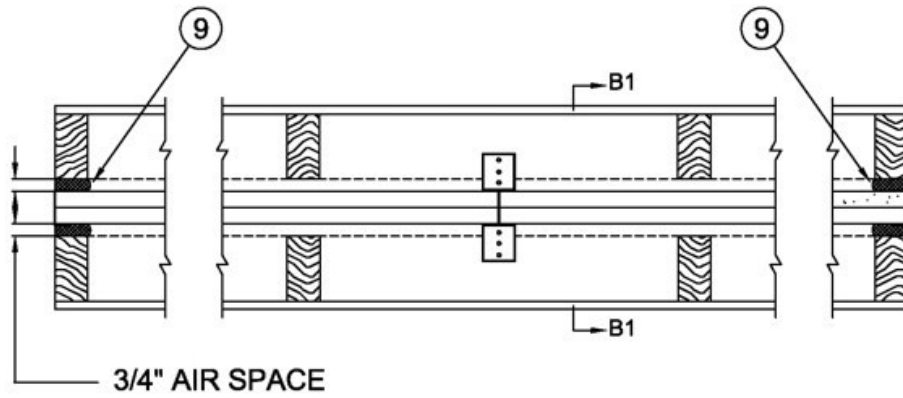

CONFIGURATION B
EXPOSED TO FIRE FROM EITHER SIDE

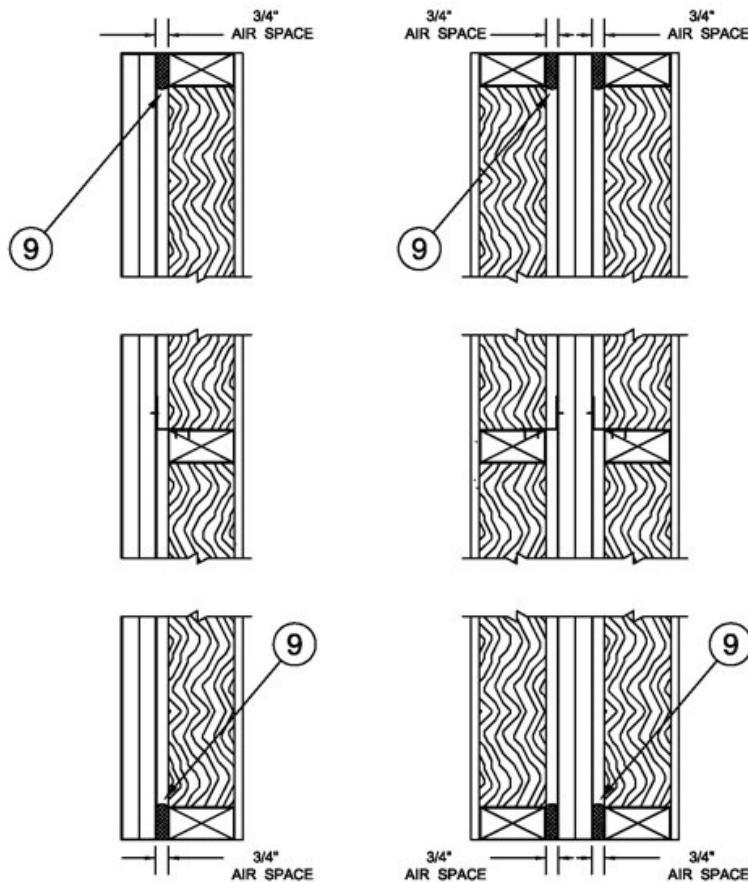

SECTION A1-A1

SECTION B1-B1

AREA SEPARATION WALL: — (Nonbearing, Max Height - 44 ft)

1. **Floor, Intermediate or Top Wall** — 2-3/16 in. wide channel shaped with 1 in. long legs formed from No. 25 MSG galv steel, secured with suitable fasteners spaced 24 in. OC.
2. **Steel Studs** — Steel members formed from No. 25 MSG galv steel having "H" - shaped flanges spaced 24 in. OC; overall depth 2-1/8 in. and flange width 1-1/2 in.
3. **Gypsum Board*** — Two layers of 1 in. thick gypsum wallboard liner panels, supplied in nom 24 in. widths. Vertical edges of panels friction fitted into "H" - shaped studs.

GEORGIA-PACIFIC GYPSUM L L C — Types TRSL, DGUSL

PROTECTED WALL: (Bearing or Nonbearing Wall, as indicated in Items 4, 4A and 4B. When Bearing, Load Restricted for Canadian Applications — See Guide [BXUV7](#).)

4. **Wood Studs** — For 2 Hr. Bearing or Nonbearing Wall Rating - Nom 2 by 4 in., max spacing 24 in. OC. Studs cross-braced at midheight where necessary for clip attachment. Min 3/4 in. separation between wood framing and area separation wall. Finish rating evaluated for wood studs only.
- 4A. **Steel Studs** — (As an alternate to Item 4, not shown) — For 2 Hr. Bearing Wall Rating - Corrosion protected steel studs, min No. 20 MSG (0.0329 in., min bare metal thickness) steel or min 3- 1/2 in. wide, min No. 20 GSG (0.036 in. thick) galv steel or No. 20 MSG (0.033 in. thick) primed steel, cold formed, shall be designed in accordance with the current edition of the Specification for the Design of Cold-Formed Steel Structural Members by the American Iron and Steel Institute. All design details enhancing the structural integrity of the wall assembly, including the axial design load of the studs, shall be as specified by the steel stud designer and/or producer, and

shall meet the requirements of all applicable local code agencies. The max stud spacing of wall assemblies shall not exceed 24 in. OC. Studs attached to floor and ceiling tracks with 1/2 in. long Type S-12 steel screws on both sides of studs or by welded or bolted connections designed in accordance with the AISI specifications. Top and bottom tracks shall consist of steel members, min No. 20 MSG (0.0329 in., min bare metal thickness) steel or min No. 20 GSG (0.036 in. thick) galv steel or No. 20 MSG (0.033 in. thick) primed steel, that provide a sound structural connection between steel studs, and to adjacent assemblies such as a floor, ceiling, and/or other walls. Attached to floor and ceiling assemblies with steel fasteners spaced not greater than 24 in. O.C. Studs cross-braced with stud framing at midheight where necessary for clip attachment. Min 3/4 in. separation between steel framing and area separation wall. Finish rating has not been evaluated for Steel Studs.

4B. Steel Studs — (As an alternate to Items 4 and 4A, for use in Configuration B only, not shown) — For 2 Hr. Nonbearing Wall Rating - Channel shaped, fabricated from min 25 MSG corrosion-protected steel, min 3-1/2 in. wide, min 1-1/4 in. flanges and 1/4 in. return, spaced a max of 24 in. OC. Studs to be cut 3/8 to 3/4 in. less than assembly height. Top and bottom tracks shall be channel shaped, fabricated from min 25 MSG corrosion-protected steel, min width to accommodate stud size, with min 1 in. long legs, attached to floor and ceiling with fasteners 24 in. OC max. Studs cross-braced with stud framing at midheight where necessary for clip attachment. Min 3/4 in. separation between steel framing and area separation wall. Finish rating has not been evaluated for Steel Studs.

5. Gypsum Board — Classified or Unclassified - Min 1/2 in thick, 4 ft wide, applied either horizontally or vertically. Wallboard attached to wood studs (Item 4) with 1-1/4 in. long steel drywall nails spaced 12 in. OC. Wallboard attached to steel studs (Item 4A or 4B) with 1 in. long Type S steel screws spaced 12 in. OC. Vertical joints located over studs. (Optional) Joints covered with paper tape and joint compound. Nail or screw heads covered with joint compound.

5A. Plywood Sheathing or OSB — (Not shown) — As an alternate to Item 5, Nominal 1/2 in. thick or greater plywood or OSB applied horizontally or vertically to wood or steel studs. Vertical joints located over studs. Horizontal joints shall be butted tight to form a closed joint. Fastened to studs with nails or screws of sufficient length, spaced 12 in. OC. Joints and fastener heads are not required to be treated. Aluminum clips shall be spaced as described in Item 6.

6. Attachment Clips — Aluminum angle, 0.062 in. thick, min 2 in. wide with min 2 in. and 2-1/2 in. legs. Clips secured with minimum one Type S screw 3/8 in. long to "H" studs and with minimum one Type W screw 1-1/4 in. long to wood framing or steel framing through holes provided in clip. Clips spaced a max of 10 ft OC vertically between wood or steel framing and "H" studs for separation walls up to 23 ft high. For separation walls up to 44 ft high, clips spaced as described above for the upper 24 ft. and the remaining wall area below requires clips spaced a max 5 ft OC vertically between wood or steel framing and "H" studs.

7. Batts and Blankets* — (Optional, not shown) — Placed in stud cavities, any glass fiber or mineral wool insulation, max 3.0 pcf density, bearing the UL Classification Marking as to Surface Burning Characteristics and/or Fire Resistance. See Batts and Blankets (BKNV or BZJZ) Categories for names of Classified companies. Min 3/4 in. separation between insulation and area separation wall.

8. Plywood Sheathing or OSB — (Optional) — Min 1/2 in. thick plywood or OSB applied horizontally or vertically to "H" studs on area separation wall side of Configuration A. Vertical joints located over studs. Fastened to "H" studs with screws of sufficient length, spaced a maximum of 12 in. OC.

9. Caulking and Sealants* — (Optional - Intended for use as an air barrier - Not evaluated as fireblocking) - A bead of sealant applied around the partition perimeter in the 3/4 in. air space between wood framing (Item 4) and shaftliner panels (Item 3) to create an air barrier.

DUPONT DE NEMOURS, INC. — Great Stuff Gaps & Cracks, Great Stuff Pro Gaps & Cracks, Great Stuff Pro Window & Door

ICP ADHESIVES & SEALANTS INC — Fireblock, Window & Door, Insulating Foam Sealant, Multi-Purpose, HC Sealants, Black Foam Sealant, Extreme, Window & Door Extreme, Fast Foam, Gun Foam, and Straw Foam

*** Indicates such products shall bear the UL or cUL Certification Mark for jurisdictions employing the UL or cUL Certification (such as Canada), respectively.**

Last Updated on 2022-02-16

The appearance of a company's name or product in this database does not in itself assure that products so identified have been manufactured under UL Solutions' Follow - Up Service. Only those products bearing the UL Mark should be considered to be Certified and covered under UL Solutions' Follow - Up Service. Always look for the Mark on the product.

UL Solutions permits the reproduction of the material contained in Product iQ subject to the following conditions: 1. The Guide Information, Assemblies, Constructions, Designs, Systems, and/or Certifications (files) must be presented in their entirety and in a non-misleading manner, without any manipulation of the data (or drawings). 2. The statement "Reprinted from Product iQ with permission from UL Solutions" must appear adjacent to the extracted material. In addition, the reprinted material must include a copyright notice in the following format: "©2024 UL LLC."