

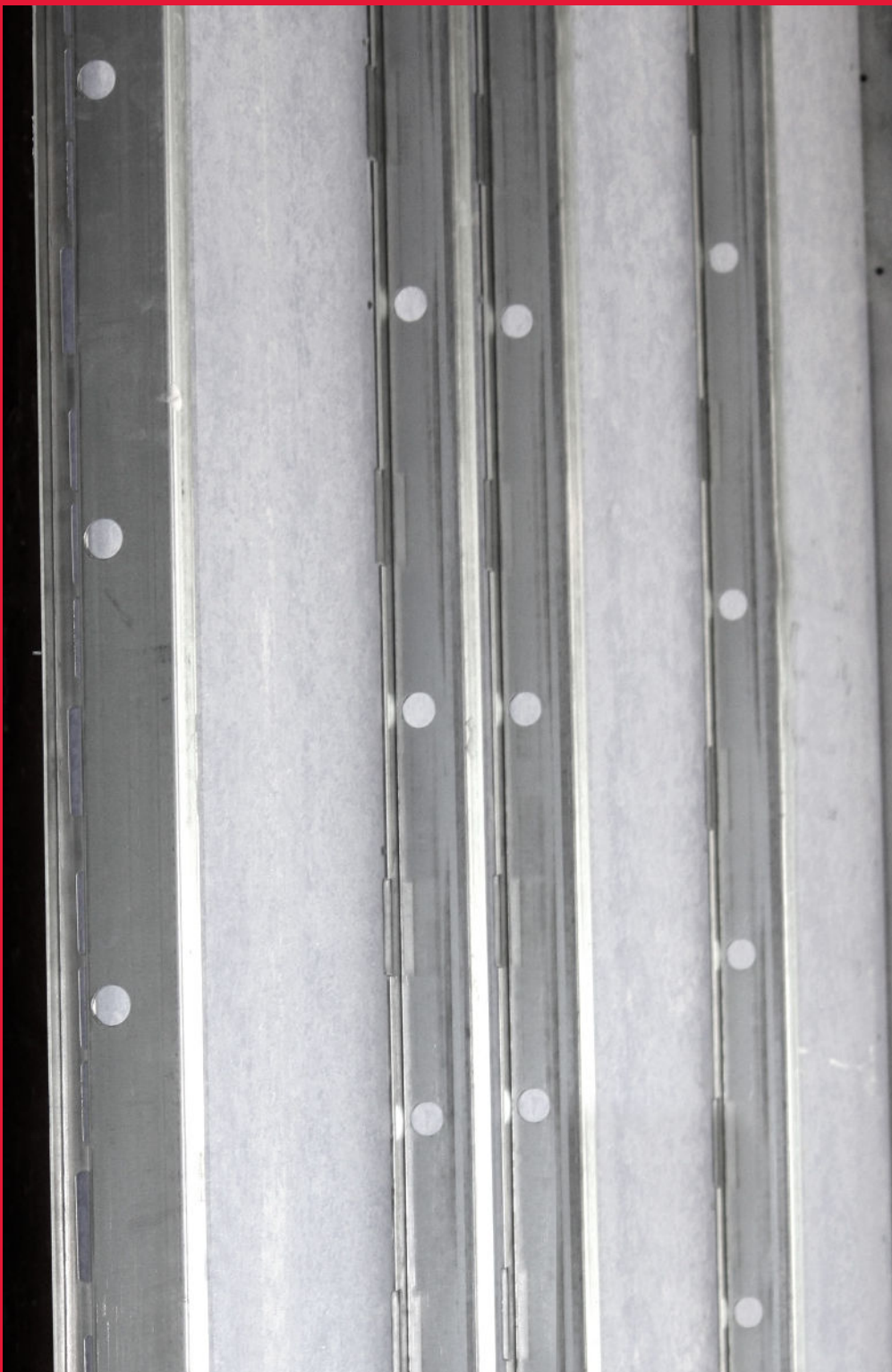

PRODUCT CATALOG
SHAFTWALL + AREA SEPARATION WALL SYSTEMS



SHAFTWALL + AREA SEPARATION WALL SYSTEMS



YOUR SUCCESS DEPENDS ON QUALITY BUILDING PRODUCTS AND SO DOES OURS.

For over 30 years, Marino\WARE®, a division of Ware Industries, has provided customers with top quality cold-formed steel framing products. We are committed to providing a superior customer experience through a vast selection of readily available products, a knowledgeable sales team, comprehensive technical support and services, prompt delivery through our fleet of trucks, and an extensive distribution network.

Our best-in-class product development team delivers innovative solutions to installation and cost challenges with products designed to save time, labor, and materials. In addition, we utilize the latest in roll forming techniques, maintain the latest level of technology available to the steel framing industry, and strictly adhere to all ASTM specifications.

Marino\WARE is 100% American-owned and operated. We take pride in creating local jobs, supporting local communities, and manufacturing products that reflect the uncompromising skill and ethics of our professional team. We operate state-of-the-art production facilities in New Jersey, Georgia, and Indiana, as well as a sales office in New York.

Visit MarinoWARE.com to experience our full line of innovative solutions.

TECHNICAL SERVICES + SUPPORT | *DesignGroup*

Our commitment to quality products extends to best-in-class design support. The Marino\WARE® DesignGroup™ offers a full range of technical support and engineering services, including professionally engineered stamped shop drawings, design and installation assistance on all Marino\WARE manufactured products, and expert advice on structural, nonstructural, fire and acoustic assemblies.

If you have questions or need more information on any of the products listed in this catalog, contact our Technical Services department at technicalservices@marinoware.com, or at 866.545.1545. In most cases Technical Services representatives can provide an immediate response.

Warranty & Limitations

All products presented herein are warranted to the buyer to be free from defects in material and workmanship. The foregoing warranty is non-assignable and in lieu of and excludes all other warranties not expressly set forth herein, whether express or implied by operation of law or otherwise, including but not limited to any implied warranties of merchantability or fitness for a particular purpose. All details and specifications presented herein are intended as a general guide for the use of Marino\WARE® framing systems. These products should not be used without evaluation by a qualified engineer or architect to determine their suitability for a specific use.

Marino\WARE® assumes no responsibility for failure resulting from use of its details or specifications, or for failure resulting from improper application or installation of these products.

Governing Law

All issues arising in connection with your order and all transactions associated with it shall be interpreted according to the laws of the State of New Jersey, and all actions or other proceedings arising out of such issues shall be brought only in Superior Court, State of New Jersey, County of Essex, or United States District Court for the District of New Jersey. No action may be brought more than one year after accrual of the cause of action therefore.

GENERAL INFORMATION

ASTM SPECIFICATION DESCRIPTIONS

A1003 - Standard specification for steel sheet, carbon, metallic and nonmetal-coated for cold formed framing members

A653 - Standard specification for steel sheet, zinc-coated (galvanized) or zinc-iron alloy coated by hot-dip process

A924 - Standard specification for general requirements for steel sheet, metallic-coated by the hot-dip process

C645 - Standard specification for non structural steel framing members

C754 - Standard Specification for Installation of Steel Framing Members to Receive Screw-Attached Gypsum Panel Products

AISI S220 - North American Standard for Cold-Formed Steel Framing - Nonstructural Members

LEED® INFORMATION - MATERIALS & RESOURCES

MarinoWARE is proud to support the building industry in its efforts to create sustainable commercial and residential buildings. We support the Leadership in Energy & Environmental Design (LEED®) program and have LEED® accredited professionals on staff. Using products manufactured by MarinoWARE® can help in accumulating LEED® points in several categories.

TABLE OF CONTENTS

SHAFTWALL:

CT Stud, Tabbbed Track and Jamb Track4
 Physical Properties4
 Vertical Limiting Heights.....5
 Horizontal Spans5
 Shaftwall Fire and Sound Rating Summaries6
 Installation Instructions7
 Construction Details8

AREA SEPARATION WALL:

H-Stud, C-Runner and Aluminum Break Away Clip10
 Product Assembly,.....10
 Area Separation Wall Fire Rating Summaries11
 Area Separation Wall Installation Instructions12
 Suggested Details for Area Separation Wall System12
 Architectural Specifications13

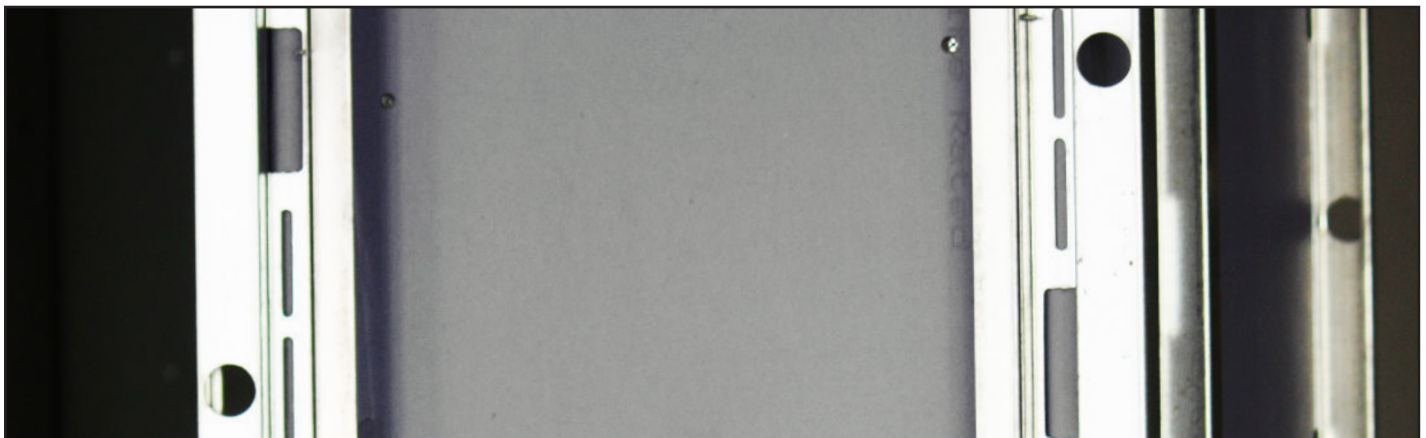

CT STUD, TABBED TRACK & JAMB TRACK

MarinoWARE® created its CT Shaftwall System, to be a flexible shaftwall assembly that can accommodate any UL Classified gypsum liner board for maximum versatility in design, purchase, and construction. The MarinoWARE CT Shaftwall System is comprised of CT-Stud and Tabbed Track components, resulting in easier installation and fewer parts to inventory and purchase.

Features include:

- Fire rated
- Full range of sizes: 2 1/2", 4", and 6"
- 25, 20 and 18 gauges
- Multiple production locations
- Next day delivery options
- One-sided installation design

PHYSICAL PROPERTIES							SECTION PROPERTIES				
MODEL NO.	WEB	GAUGE	MIL	KSI	DESIGN (in)	COATING	WEIGHT (lb/ft)	AREA (in ²)	I _x (in ⁴)	S _x (in ³)	
212CT25	2-1/2"	25	18	40	0.0188	G40	0.456	0.134	0.127	0.0939	
212CT20	2-1/2"	20	33	40	0.0346	G40	0.833	0.245	0.226	0.166	
400CT25	4"	25	18	40	0.0188	G40	0.552	0.162	0.387	0.185	
400CT20	4"	20	33	40	0.0346	G40	1.010	0.297	0.695	0.331	
400CT18	4"	18	43	40	0.0451	G60	1.310	0.385	0.892	0.424	
600CT20	6"	20	33	40	0.0346	G40	1.250	0.366	1.850	0.598	
600CT18	6"	18	43	40	0.0451	G60	1.620	0.475	2.380	0.770	

Notes:

1. Tabbed Track and Jamb Track available in same size and gauge as CT studs
2. L_x = Moment of inertia
3. S_x = Section modulus
4. A = Sectional area

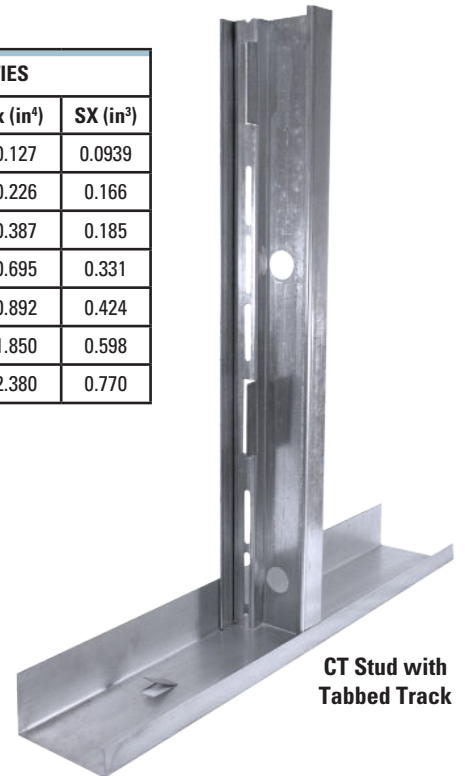

CT Stud with Tabbed Track

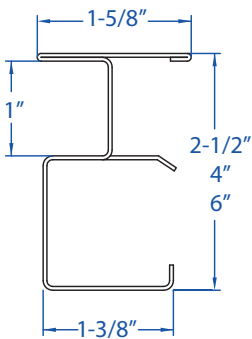

CT Stud

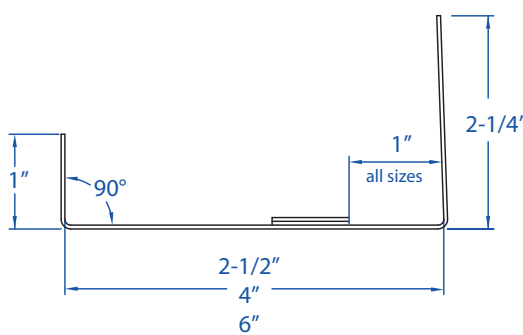

Tabbed Track

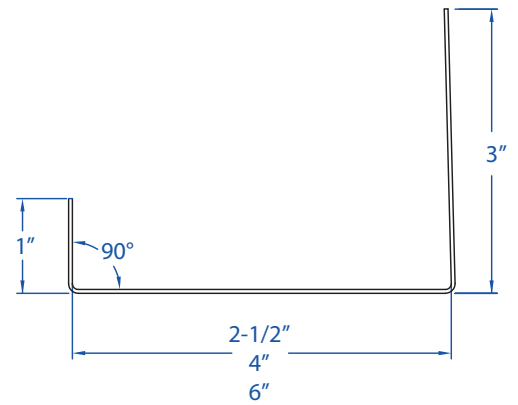

Jamb Track

CT STUD LIMITING HEIGHTS & HORIZONTAL SPANS

1 Hour Shaftwall System - limiting heights

DEPTH	GAUGE	DESIGN (in)	mil	5 PSF				7.5 PSF				10 PSF			
				L/120	L/180	L/240	L/360	L/120	L/180	L/240	L/360	L/120	L/180	L/240	L/360
2-1/2"	25	0.0188	18	13'-3"f	11'-11"	10'-10"	9'-5"	10'-10"f	10'-5"	9'-5"	8'-3"	9'-5"f	9'-5"	8'-7"	7'-6"
4"	25	0.0188	18	17'-6"f	15'-4"	13'-11"	12'-2"	14'-3"f	13'-5"	12'-2"	10'-8"	12'-4"f	12'-2"	11'-1"	9'-8"
2-1/2"	20	0.0346	33	17'-7"	15'-5"	14'-0"	12'-3"	15'-5"	13'-5"	12'-3"	10'-8"	13'-0"	12'-3"	11'-1"	9'-8"
4"	20	0.0346	33	21'-11"f	19'-3"	17'-6"	15'-3"	17'-11"f	16'-10"	15'-3"	13'-4"	15'-6"f	15'-3"	13'-11"	12'-2"
6"	20	0.0346	33	24'-6"f	24'-6"f	24'-6"f	22'-7"	20'-0"f	20'-0"f	20'-0"f	19'-9"	17'-4"f	17'-4"f	17'-4"f	17'-4"f
4"	18	0.0451	43	21'-11"f	19'-3"	17'-6"	15'-3"	17'-11"f	16'-10"	15'-3"	13'-4"	15'-6"f	15'-3"	13'-11"	12'-2"
6"	18	0.0451	43	28'-1"f	28'-1"f	27'-10"	24'-3"	22'-11"f	22'-11"f	22'-11"f	21'-3"	19'-10"f	19'-10"f	19'-10"f	19'-3"

2 Hour Shaftwall System - limiting heights

DEPTH	GAUGE	DESIGN (in)	mil	5 PSF				7.5 PSF				10 PSF			
				L/120	L/180	L/240	L/360	L/120	L/180	L/240	L/360	L/120	L/180	L/240	L/360
2-1/2"	25	0.0188	18	14'-5"	12'-7"	11'-5"	10'-0"	12'-7"	11'-0"	10'-0"	8'-9"	11'-2"f	10'-0"	9'-1"	7'-11"
4"	25	0.0188	18	18'-6"	16'-2"	14'-8"	12'-10"	16'-0"f	14'-2"	12'-10"	11'-3"	13'-10"f	12'-10"	11'-8"	10'-2"
2-1/2"	20	0.0346	33	17'-0"	14'-10"	13'-6"	11'-9"	14'-10"	13'-0"	11'-9"	10'-4"	13'-6"	11'-9"	10'-9"	9'-4"
4"	20	0.0346	33	23'-8"	20'-8"	18'-9"	16'-5"	20'-8"	18'-1"	16'-5"	14'-4"	18'-9"	16'-5"	14'-11"	13'-0"
6"	20	0.0346	33	28'-10"f	28'-10"	26'-4"	23'-0"	23'-6"f	23'-6"	23'-0"	20'-1"	20'-5"f	20'-5"f	20'-5"f	18'-3"
4"	18	0.0451	43	23'-8"	20'-8"	18'-9"	16'-5"	20'-8"	18'-1"	16'-5"	14'-4"	18'-9"	16'-5"	14'-11"	13'-0"
6"	18	0.0451	43	30'-0"f	30'-0"f	28'-7"	25'-0"	24'-6"f	24'-6"f	24'-6"f	21'-10"	21'-2"f	21'-2"f	21'-2"f	19'-10"

2 Hour Stairwell System - limiting heights

DEPTH	GAUGE	DESIGN (in)	mil	5 PSF				7.5 PSF				10 PSF			
				L/120	L/180	L/240	L/360	L/120	L/180	L/240	L/360	L/120	L/180	L/240	L/360
2-1/2"	25	0.0188	18	15'-7"	13'-8"	12'-5"	10'-10"	12'-9"	11'-11"	10'-10"	9'-5"	11'-0"f	10'-10"	9'-10"	8'-7"
4"	25	0.0188	18	17'-9"f	17'-6"	15'-11"	13'-11"	14'-6"f	14'-6"f	13'-11"	12'-2"	12'-7"f	12'-7"f	12'-7"	11'-0"
2-1/2"	20	0.0346	33	19'-6"f	17'-5"	15'-10"	13'-10"	15'-11"f	15'-3"	13'-10"	12'-1"	13'-9"f	13'-9"f	12'-7"	11'-0"
4"	20	0.0346	33	22'-4"f	22'-4"f	20'-8"	18'-0"	18'-3"f	18'-3"f	18'-0"	15'-9"	15'-9"f	15'-9"f	15'-9"f	14'-4"
6"	20	0.0346	33	25'-1"f	25'-1"f	23'-5"	20'-6"	20'-5"f	20'-5"f	20'-5"f	17'-11"	17'-9"f	17'-9"f	17'-9"f	16'-3"
4"	18	0.0451	43	22'-4"f	22'-4"f	20'-8"	18'-0"	18'-3"f	18'-3"f	18'-0"	15'-9"	15'-9"f	15'-9"f	15'-9"f	14'-4"
6"	18	0.0451	43	28'-1"f	28'-1"f	26'-0"	22'-9"	22'-11"f	22'-11"f	22'-9"	19'-10"	19'-11"f	19'-11"f	19'-11"	18'-0"

Shaftwall Systems - Horizontal Spans (dead load only)

DEPTH	GAUGE	DESIGN (in)	mil	1 Hour				2 Hour			
				L/120	L/180	L/240	L/360	L/120	L/180	L/240	L/360
2-1/2"	25	0.0188	18	11'-7"f	10'-11"	9'-11"	8'-8"	12'-2"	10'-7"	9'-8"	8'-5"
2-1/2"	20	0.0346	33	15'-8"	13'-8"	12'-5"	10'-10"	13'-11"	12'-2"	11'-1"	9'-8"
4"	25	0.0188	18	15'-1"	14'-0"	12'-8"	11'-1"	14'-11"f	13'-7"	12'-4"	10'-9"
4"	20	0.0346	33	17'-11"	16'-10"	15'-3"	13'-4"	17'-6"f	16'-9"	15'-3"	13'-4"
6"	20	0.0346	33	19'-5"f	19'-5"f	19'-5"f	19'-5"f	18'-0"f	18'-0"f	18'-0"f	18'-0"
6"	18	0.0451	43	21'-7"f	21'-7"f	21'-7"f	20'-4"	18'-3"f	18'-3"f	18'-3"f	18'-3"f

Notes:
 (F) Indicates flexure controls
 24" o.c. only framing
 Horizontal spans do not carry live loads, equipment, lighting or storage loads.

SHAFTWALL FIRE & SOUND RATING SUMMARIES

1 HOUR SHAFTWALL ASSEMBLY

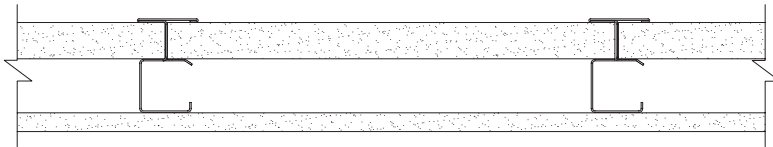

Test Reference:
Warnock-Hersey

Fire Components

- Any UL Classified 1" thick Liner Board Type X,
- MarinoWARE® CT Stud and Tabbed Track
- Any UL Classified of one layer of 5/8" Type X or 1/2" Type C gypsum wallboard, oriented vertically.

Sound Rating (STC)

- 2 1/2" CT=38/41*
- 4" CT=41/47*
- 6" CT=44/48*

2 HOUR SHAFTWALL ASSEMBLY

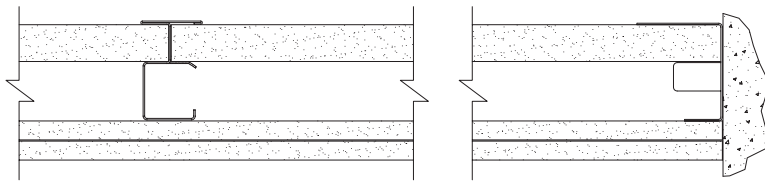

Test Reference:
Warnock-Hersey

Fire Components

- Any UL Classified 1" thick Liner Board Type X,
- MarinoWARE® CT Stud and Tabbed Track
- Any UL Classified of two layers of 5/8" Type X or 1/2" Type C gypsum wallboard, oriented vertically.

Sound Rating (STC)

- 2-1/2" CT=41/46*
- 4" CT=44/49*
- 6" CT=46/49*

2 HOUR STAIRWALL ASSEMBLY

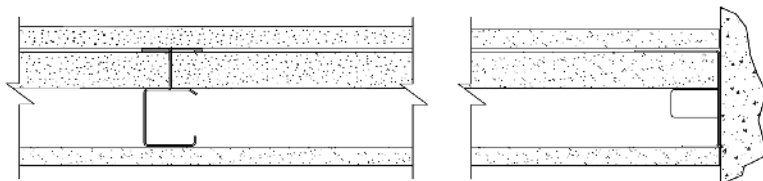

Test Reference:
Warnock-Hersey

Fire Components

- Any UL Classified 1" thick Liner Board Type X,
- MarinoWARE® CT Stud and Tabbed Track
- Any UL Classified of two layers of 5/8" Type X or 1/2" Type C gypsum wallboard, oriented vertically.

Sound Rating (STC)

- 2-1/2" CT=40/45*
- 4" CT=45/49*
- 6" CT=45/50*

Notes:

* Represents the same assembly with the addition of 1-1/2" of blanket insulation installed in the cavity.

Generic UL Assemblies for CT Studs*			NYC Approval
UL U417	UL U499	UL V473	CT Stud - MEA 148-05-M (2 Hours) CT Stud - MEA 148-05-M Vol. 2
UL U428	UL V451	UL V481	
UL U429	UL V455	UL V493	
UL U497	UL V470	UL W414	
UL U498	UL V472	UL W419	

*Note: Always follow the specific fire rated design requirements

SHAFTWALL INSTALLATION INSTRUCTIONS*(Verify UL design assembly requirements)*

1. Layout Shaftwall in locations indicated on construction drawings. Position top and bottom Tabbled Track with long leg toward the shaft. Secure Tabbled Track perimeter framing and plumb to ceiling, floor, and sides. Attached with approved fasteners, spaced not more than 24" o.c. Apply non-hardening, flexible sealant in a continuous application at the perimeter.
2. Pre-plan the CT-Stud layout 24" o.c. and adjust the spacing at either end so that the terminal stud will not fall closer than 8" from the end. Pieces less than 8" may pose handling and installation problems such as cracking and breaking. Maximum spans are as shown on page 5.
3. Install the first 1" Liner Board panel. The panel length shall be $\frac{3}{4}$ " less than the total height of the framed section. Plumb the panel against the web of the Tabbled Track and secure with bend out tabs in Tabbled Track or with 1-5/8" Type S screws at 24" o.c. to secure the panel in place.
4. Insert a MarinoWARE® CT-Stud into the top and bottom Tabbled Track and fit tightly over the previously installed 1" Liner Board panel. The CT-Stud length shall be $\frac{3}{4}$ " less than the total height of the framed section. Allow equal clearance between top and bottom Tabbled Track.
5. Install the second 1" Liner Board panel inside the Tabbled Track and within the tabs of the CT-Stud.
NOTE: The edges of the panel maybe beveled to help guide the panel into the slotted and tabbed section of the stud.
6. Progressively install succeeding CT-Stud and 1" Liner Board panel as described above until the wall section is enclosed. The final Liner Board panel section maybe secured with tabs from Tabbled Track at 24" o.c. If tabs are not used, secure the Liner Board panel to the Tabbled Track with 1-5/8" Type S screws at 24" o.c.
7. Where wall heights exceed the standard or available length of the Liner Board panels, the panels shall be cut and stacked with joints occurring within the top or bottom third of the wall height. The shorter panels shall be minimum 24" long and of sufficient length to engage two studs.
8. CT-Studs cannot be spliced. They must be installed full height, one piece.
9. For doors, ducts or other large penetrations or openings, install Jamb Track as perimeter framing. Use adequate structural support for opening over 48" wide. Use 20 Gauge track with 3" back leg for elevator doors and block cavity. Install 12" wide gypsum board filler strips for doors exceeding 7'-0" height or as per required by Door Frame Manufacturer.
10. 1" Liner Board panel may be abutted, spliced or stacked within the cavity. The shorter panel should be minimum 2" long or longer to engage two stud tabs of each panel edge. Joints of adjacent panels should be alternately stacked or staggered to prevent continuous horizontal joint.
NOTE: In addition, some local codes may also require that these splices be back-blocked with a 12"x24" piece of gypsum even though the tests were conducted with these joists unblocked. Back blocking may be done with a CT-Stud of proper length and placed horizontal. Please verify with your local code jurisdiction.
11. For the Shaftwall System, finished one side, install the first layer of $\frac{1}{2}$ " UL Classified gypsum board horizontally with 1" Type S or S-12 screws spaced 24" o.c. starting 3" from top and bottom or 5/8" Type X gypsum board maybe used in lieu of $\frac{1}{2}$ " Type C gypsum board, if desired. The horizontal joints should be offset from any splice joints in the Liner Board panel by at least 12".
12. Install the face layer of board vertically with 1-5/8" Type S or S-12 screws spaced 12" o.c. starting 6" from top and bottom. All edge and end joints should be offset from the base layer by 24" o.c.
13. For the Stairwall System, finished both sides, each side may be installed either horizontally or vertically with 1" Type S or S-12 screw spaced at 12" o.c. starting 6" from top and bottom and with vertical joints offset 24". Edges and ends on opposite sides offset 24" o.c.
14. Caulk all perimeter edges and abutments with dissimilar materials, and penetrations in the facing layers with a non-hardening flexible sealant approved for this use.
15. When used as HVAC ducts, consult with HVAC engineer regarding level of caulking and sealant required. All joints on face layers are to be taped and finished and fasteners finished with joint compound meeting ASTM C475. All penetration openings are to be filled with approved fire stopping sealants.
16. For more information on firestopping through penetrations in Shaftwall systems or head of wall Shaftwall details, consult the UL directory or other fire testing agencies listings.
17. Do not stack walls. Shaftwall assemblies are non-loadbearing interior partitions only. Simple spans only and no splicing allowed. Provide for control joints per designer of record requirements.

SHAFTWALL SYSTEMS SUGGESTED CONSTRUCTION DETAILS

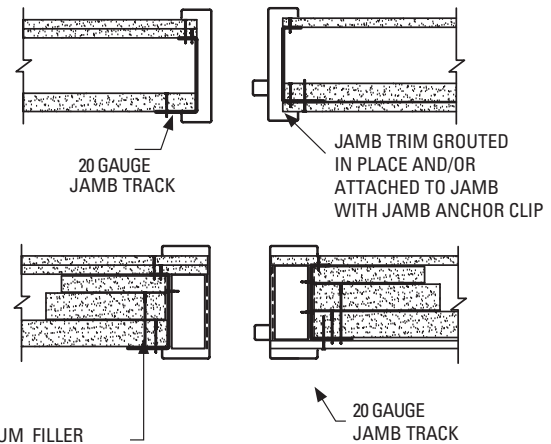
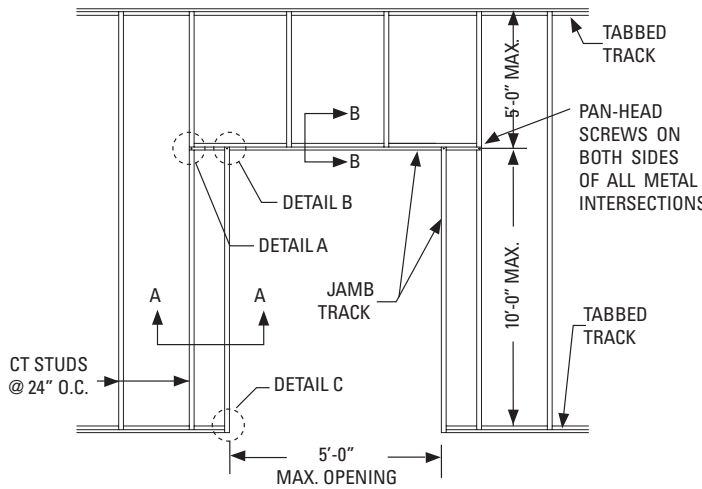

SOLID GYPSUM FILLER STRIPS AS REQUIRED FOR DOOR FRAMES

2 Jamb Detail Section A-A

NOTES:

- A.) FRAMING AT ELEVATOR DOOR SHALL BE MINIMUM 4" CT-STUDS AND RUNNERS 20 GAUGE.
- B.) FOR DOOR GREATER THAN 5' WIDE AND 10' HIGH, IT NEEDS TO BE INVESTIGATED SEPARATELY.

1 Door Frame Elevation

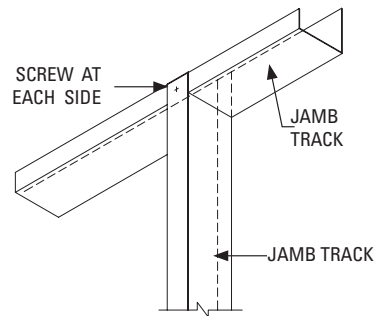
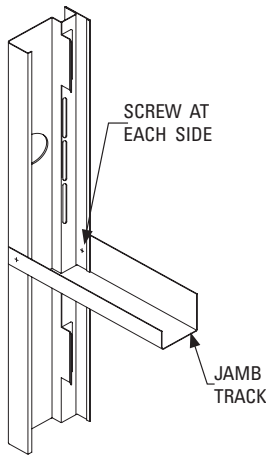

3 Header Detail Detail A

4 Header Detail Detail B

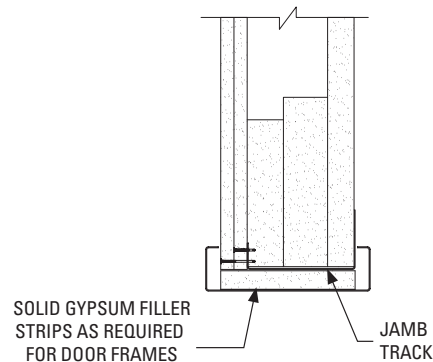
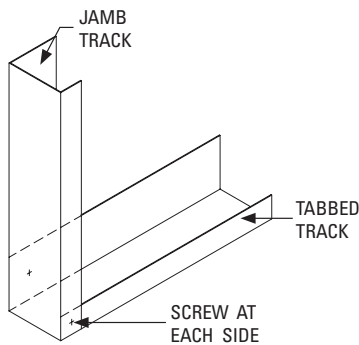

5 Jamb Detail Detail C

6 Header Detail Section B-B

SHAFTWALL SYSTEMS SUGGESTED CONSTRUCTION DETAILS

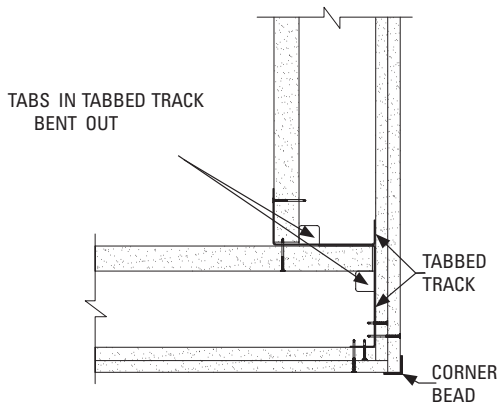

7 Outside Corner Detail

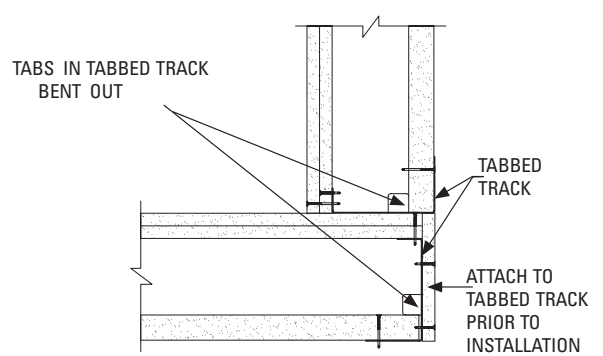

8 Inside Corner Detail

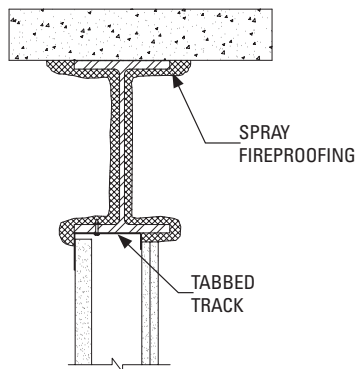

9 Steel Beam Detail

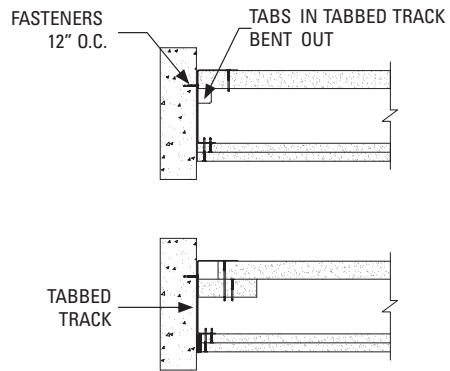

10 End of Wall Detail

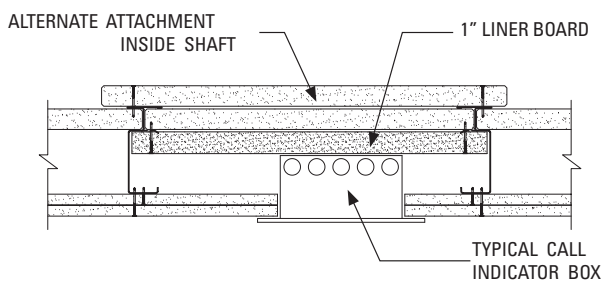

11 Call Box/Outlet Box/Mail Chute

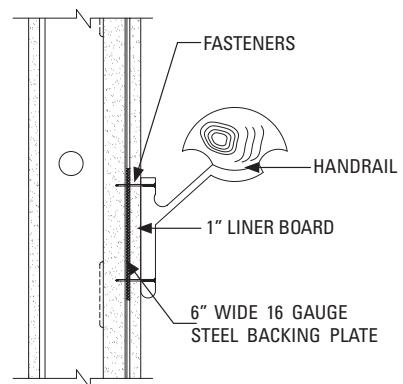

12 Handrail Connection

H-STUD, C-RUNNER, ALUMINUM BREAKAWAY CLIP & ASSEMBLY DETAILS

Area Separation Walls

The Marino\WARE® Area Separation Wall is constructed once the framing for one multistory unit is complete and prior to the construction of the interior framing on the adjacent unit. The area separation wall is constructed a minimum 3/4" away from the adjacent framing, which is typically constructed from wood. In many cases the area separation wall is positioned 1" away from the wall framing to accommodate the 1" Liner Board panels used as fire blocking between the floor levels.

PHYSICAL PROPERTIES						SECTION PROPERTIES					
Model No.	Web	GA.	Mil	Design Thickness	Coating	Weight (lb/ft)	Area (in2)	Ix	Sx	Iy	Sy
216HS25	2"	25	18	0.0188"	G40	0.4310	0.1270	0.0990	0.0995	0.0147	0.0176
216HS20	2"	20	30	0.0312"	G40	0.7150	0.2100	0.1681	0.1582	0.0243	0.0289

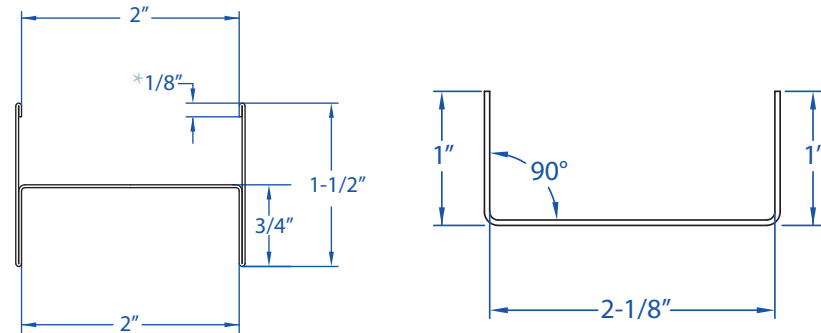

H-Stud

C-Runner

* - 20 Gauge Not Hemmed

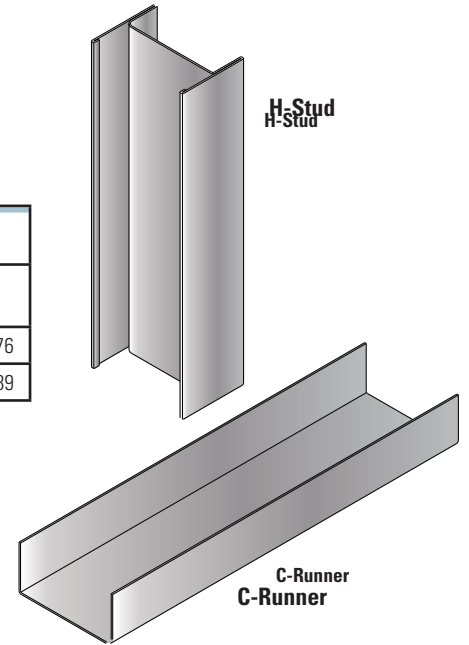

Breakaway Clip (BA)

BA clips allow a fire damaged structure to collapse while permitting the fire wall to remain in place, protecting adjacent units.

- For use with Area Separation Wall Systems
- Aluminum .063" or .049"
- Designed to melt under extreme heat

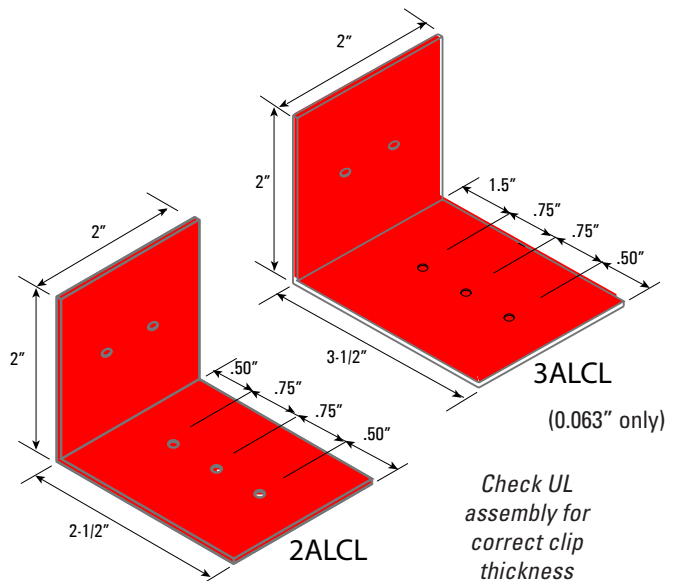
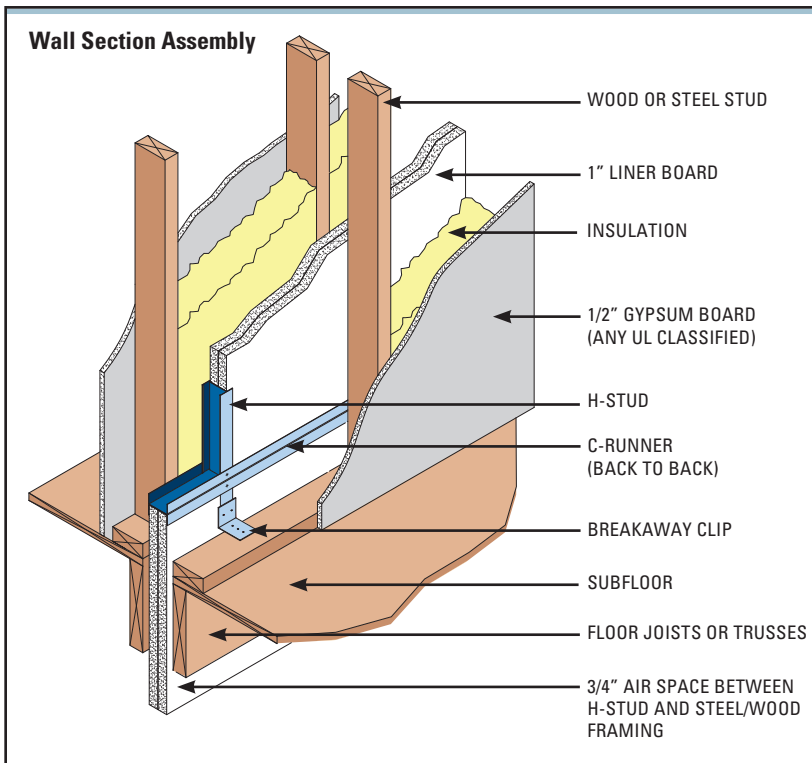

(available in 0.049" or 0.063" thickness)

Check UL assembly for correct clip thickness

AREA SEPARATION WALL FIRE & SOUND RATING SUMMARY

Area Separation Wall Test Data

Fire Components:

- Any UL Classified 1/2" gypsum wallboard, oriented vertically or horizontally to wood framing. One (1) layer each side of assembly.
- Wood Framing - Nominal: 2" x 4" wood framing, spaced 24" oc maximum and spaced 3/4" from shaftwall surface -OR-
- Steel Framing - Bearing: 3-1/2" min. depth x 1-5/8" min. flange 20 gauge stud, spaced 24" o.c. maximum and 3/4" from shaftwall surface.
- Steel Framing - Non Bearing: 3-5/8" min. depth x 1-1/4" min. flange 25 gauge stud, spaced 24" o.c. maximum and 3/4" from shaftwall surface.
- 2" long aluminum breakaway clip attached to wood or steel framing.
- Any UL Classified 1" Type X Gypsum Linear boards. Two boards back-to-back are inserted against the web of the track and into the recess of the studs.
- Marino\WARE® H Stud – 2", 25 Gauge .0179" (18 mil) – 33 ksi

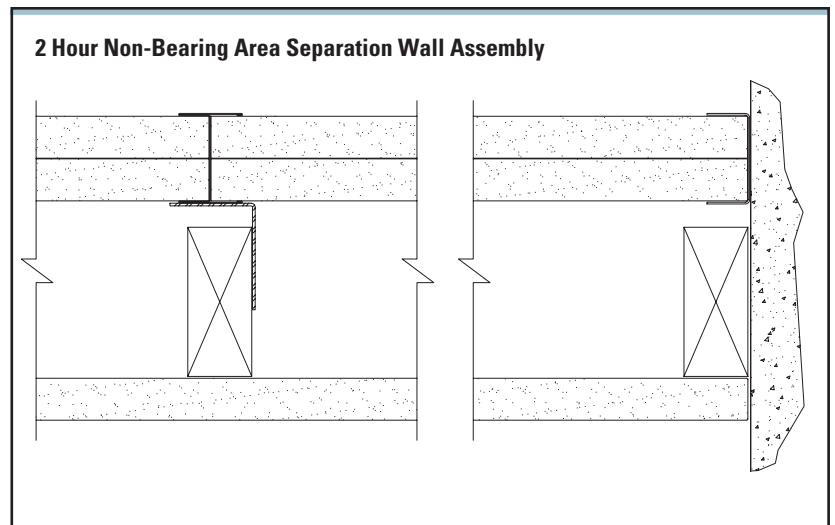
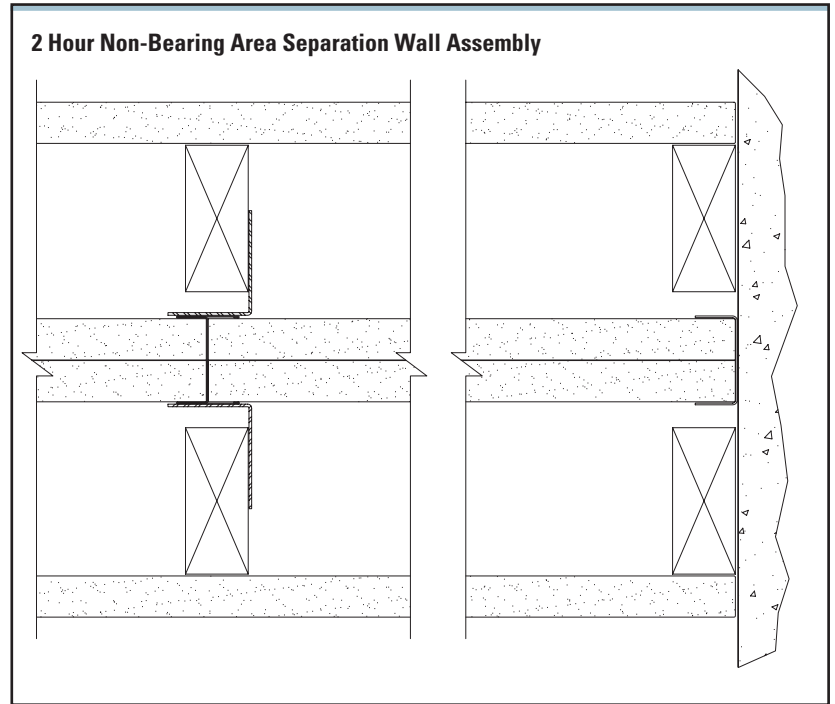

Generic UL Assemblies for CT Studs*			NYC Approval
UL U336	UL U366	UL U375	MEA 161-05-M
UL U347	UL U373	UL U388	
		UL W454	

*Note: Always follow the specific fire rated design requirements

INSTALLATION INSTRUCTIONS & DETAILS

(Verify UL design assembly requirements)

Erecting the 2" Area Separation Wall

1. Position 2" Marino\WARE® C Runner a minimum 3/4" from the framed wall of the adjacent unit. Fasten C Runner to foundation with power-driven fasteners spaced a maximum of 24" o.c. When specified, apply a minimum 1/4" of acoustical sealant under the C-Runner to maximize acoustical privacy. Run the C-Runner to the end of the foundation. In the case of offset units, run the C-Runner to the end of the offset unit.
2. Install Marino\WARE H Studs and 1" Liner Board to a maximum height of 2' above the first floor line. Install two 1" Liner Board panels vertically into the C Runner at one end of the wall. Install the H Stud over the double beveled edges of the Liner Board panels and continue alternately until the wall has reached the opposite end of the foundation. Terminate the wall using a C-Runner. The vertical C Runners at each end of the wall should be attached in the corners to the horizontal sections of C-Runner using a 3/8" pan head screw.
3. Cap the first section of the area separation wall with a C-Runner and attach to the vertical C-Runner in the corners using a 3/8" pan head screw.
4. Aluminum breakaway clips span the minimum 3/4" airspace and provide a fusible link between the H Studs and the adjacent wall framing. Attach the aluminum breakaway clips to the flange of the H Stud using one 3/8" pan head screw and to the adjacent wood framing using one 1-1/4" drywall screw. The aluminum break away clips are typically located vertically at each floor level (10'-0" o.c.) and horizontally on every H-Stud (24" o.c.). When the total height of the area separation wall exceeds 20' - 0", aluminum breakaway clips shall be installed every 5'-0" for the lower 20'-0" and every 10'-0" for the upper 30'-0" of the wall assembly. Aluminum breakaway clips are installed on both sides of the area separation wall.
5. Fire blocking is installed on both sides of the area separation wall at each floor level as defined in the IBC.
6. To continue the wall, install a C Runner over the C Runner used to cap the lower section, placed back to back and attached together with two 3/8" screws at ends and 24" o.c. Stagger end joints at least by 12"
7. The support walls located adjacent to, and on each side of the solid 2" area separation wall, protect and maintain the required 3/4" air space. These support walls offer increased acoustical privacy and provide necessary aesthetics. They can be designed as load bearing. These walls can readily accommodate code compliant electrical and plumbing systems. These systems should not impede the required 3/4" air space. Apply acoustical sealant around penetrations for maximum acoustical privacy.
8. Once the 2" area separation wall is erected, construction of the adjacent interior wall framing can begin. Aluminum Breakaway clip and fire blocking installation is identical for both sides of the 2" area separation wall.

Suggested details for Area Separation Systems

Full Wall Detail

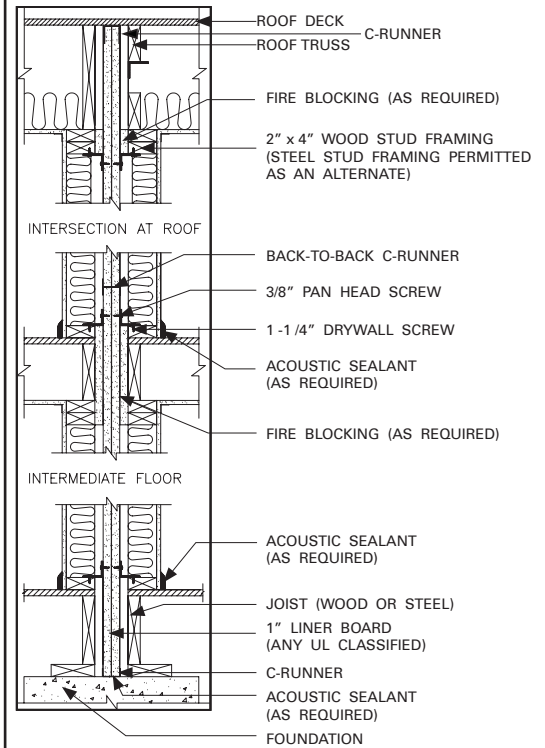

Intermediate Floor Detail

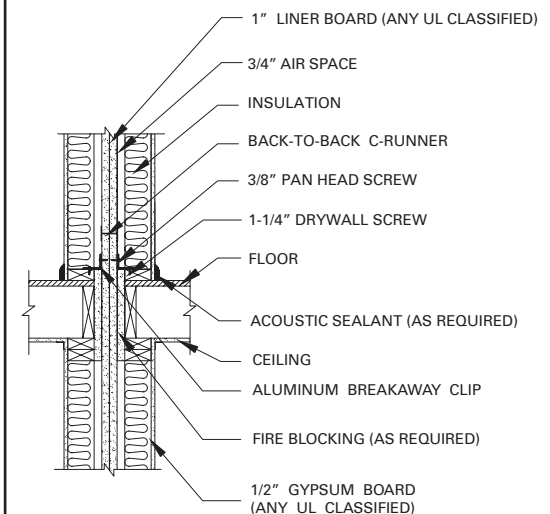

ARCHITECTURAL SPECIFICATIONS

PART 1 – GENERAL

1.0 Description of Work

Types of Work: The types of work herein specified include, but are not limited to, CT Shaftwall, CT Stairwall and H-Stud Area Separation Wall System.

1.1 Quality Assurance

- A. Fire Resistance Ratings: Where shaftwall/stairwall systems with fire resistance ratings are indicated, provide UL Classified Liner Board.
- B. Provide fire resistance rated assemblies identical to those indicated by reference to WHI (Warnock Hersey International) numbers or in listing of other testing agencies acceptable to authorities having jurisdiction.

1.2 Qualifications

All shaftwall/stairwall framing materials shall be manufactured by Marino\WARE®. All materials shall be installed in accordance with printed installation instructions as required by the testing agency.

1.3 Submittals

Product Data: Submit Marino\WARE's descriptive literature for each shaftwall/stairwall and Area Separation Wall component indicating materials, dimensions, and other data required to show compliance with the specifications.

1.4 Delivery, Storage and Handling

- C. Deliver materials in original packages, containers or bundles bearing Marino\WARE's brand name and identification.
- D. Store materials level, inside, under cover. Keep materials dry and protect from weather and damage from construction operations and other causes.
- E. Handle system components to prevent damage to edges, ends or surfaces. Protect metal accessories, framing and trim from bending and damage.

PART 2 – PRODUCTS

2.0 Materials

A. Metal framing:

1. CT Studs:
 - a. Galvanized steel, conforming to ASTM C 645 manufactured by Marino\WARE.
 - b. Width: 2½", 4" and 6"
 - c. Gauge: 18, 20 and 25 (40 ksi)
2. Tabbed Track and Jamb Track:
 - a. Galvanized steel, conforming to ASTM C 645 manufactured by Marino\WARE.
 - b. Width: 2½", 4" and 6"
 - c. Gauge: 20 at elevator doors and masonry cavities and 25 standard elsewhere. (40 ksi)

3. H-Stud and C-Runner:

- a. Galvanized steel, conforming to ASTM C 645 manufactured by Marino\WARE.
- b. Width: 2"
- c. Gauge: 25, 20 (33 ksi)
- d. Mill: 18, 30

- B. Fasteners: For 25-gauge framing – Type S screws.
For 20-gauge framing – Type S-12 screws.

PART 3 – EXECUTION

3.0 Installation

- A. General: Follow Marino\WARE recommendations for installation of metal framing.

3.1 Installation of Framing (Shaftwall/Stairwall)

- A. Installation of Tabbed Track, CT Studs and 1" Liner Board panels.
 1. Layout shaftwall in locations indicated on construction drawings.
 2. Anchor Tabbed Track perimeter framing at abutting horizontal and vertical construction.
 3. Anchor with approved fasteners spaced maximum 24" o.c.
 4. Apply non-hardening, flexible sealant in a continuous application at the perimeter.
 5. Space CT Studs at 24" o.c. Adjust the spacing at ends of shaftwall construction so end studs are minimum 8" from the ends.
 6. Install the first Liner Board panel. The panel length shall be ¾" less than the total height of the framed section. Plumb the panel against the web of the Tabbed Track and bend out tabs in Tabbed Track to secure the panel in place.
 7. Insert a CT Stud into the top and bottom Tabbed Track and fit tightly over the previously installed 1" panel. Allow equal clearance between track and stud at top and bottom Tabbed Track. The stud length shall be ¾" less than the total height of the framed section.
 8. Install the second 1" Liner Board panel inside the Tabbed Track and within the tabs of the CT Studs.
 9. Install succeeding studs and panels in the same manner as described for the first and second panels until the wall section is complete.
 10. Anchor the final panel section at 12" o.c. with tabs from the Tabbed Track.
 11. Where wall heights exceed the standard or available length of the Liner Board panels, the panels shall be cut and stacked with joints occurring within the top or bottom third of the wall height. The shorter panels shall be minimum 24" long and of sufficient length to engage 2 studs.

MARINOWARE®

12. For doors, ducts or other large penetrations or openings, install Jamb Track as perimeter framing. Use 20-gauge track with a 3" back leg for elevator doors and block cavity. Install 12" wide gypsum filler strips for doors exceeding 7'-0" height.

3.2 Installation of Framing (Area Separation Wall)

1. Foundation: Position 2" C-Runner at floor and attach securely to foundation at ends and 24" o.c. Caulk under runner at foundation with min. 1/4" bead of acoustical sealant when specified to reduce noise transmission.
2. First Floor: Install H-Studs and insert Liner Board. Attach two thicknesses of 1" Liner Board vertically in C-Runner with long edges in H-Stud. Continue installing H-Studs and Liner Board alternately until wall is complete. Attach horizontal C-Runner to top of Liner Board, fastening flanges of C-Runner at all corners on both sides of Liner Board with 3/8" drill point screws.
3. Intermediate Floors: Attach C-Runner to C-Runner cap on wall below, staggering end joints at least 12". Fasten C-Runner together using double 3/8" screws at ends and 24" o.c. Fasten H-Studs to adjacent framing with aluminum breakaway clips. Attach breakaway clips to H-Stud with one 3/8" drill point screw and to adjacent wood framing with 1 1/4" drywall screw. Install fire blocking between solid wall system and adjacent framing at floor lines, bottom of truss line and any other locations according to code requirements.
4. Roof: Cut Liner Board and H-Studs to follow roof pitch. Fasten H-Studs to framing with an aluminum breakaway clip.

3.3 Installation of Gypsum Board

- A. Shaftwall/Stairwall system finished one side:
 1. Install gypsum board in a double layer on one side, either horizontally or vertically.
 2. Install the first layer of gypsum board horizontally with approved fasteners spaced 24" o.c. and 3" from all edges.
 3. Offset the horizontal joints minimum 12" from any splice joints in the Liner Board panels.
 4. Install the face layer of gypsum board parallel to the framing with approved fasteners spaced minimum 12" o.c. and 6" from all edges.
 5. Offset edge and end joints from the base layer at least 24".
- B. Stairwall/Stairwall System, Finished Both Sides:
 1. Install gypsum board on both sides, either horizontally or vertically.

2. Attach gypsum board with approved fasteners spaced 12" o.c. and 6" from all edges.
3. Offset edges and ends of gypsum board on opposite sides minimum 24".

3.4 Finishing

- A. Apply a non-hardening, flexible sealant continuous at all perimeter edges, abutments with dissimilar materials and penetrations in the facing layer.
- B. Tape and finish all joints at face layers with tape and joint compound and finish fastener heads with joint compound meeting ASTM C 475.

3.5 Protection of Work

- A. Protect shaftwall work from damage and deterioration until date of substantial completion
- B. Repair damaged work to be indistinguishable from adjacent work. Replace work that cannot be repaired as required.

LIMITATIONS:

- Non-load-bearing; not to be used as an unlined air supply duct.
- Not designed for exposure to constant high-moisture conditions or direct water.
- Elevator door assemblies require support independent of shaftwall partitions.
- Good construction practice calls for partition control joints to coincide with that of the building structure.
- Limiting loads and heights not to exceed design specifications or data provided herein or by metal component supplier.
- Provide flexible sealant/caulk at partition perimeters and penetrations to avoid air leakage/whistling and dust collection.

SOUND GUARD
THE SILENT STEEL FRAMING SYSTEM

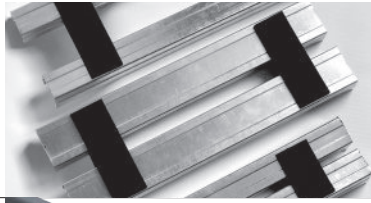

- Reduces labor and materials
- Increases available floor space
- Does not require additional bracing or resilient channel

MARINO WARE
Firestopping
Fire Bead • Fire Gasket • HotRod XL



- Firestopping and sound control for building joints
- Innovative firestop devices for faster installation
- Prevents passage of fire, smoke and toxic fumes

StudRite
JoistRite



- High strength-to-mass ratio
- Increased structural performance due to lip reinforced triangular cutouts and embossments
- Efficient design for installing plumbing, heating, electrical, and other trades
- Saves construction professionals valuable time and reduces labor costs



- Unsurpassed resistance against loads imposed by seismic activity, hurricane force winds, fire, mold, impact and blast, while actively reducing sound transmission

RC-MAX



- RC-MAX is manufactured from 0.0190" 50 KSI steel for additional strength
- Offers economical means for controlling sound transmission

ClipSource



- A comprehensive line of connectors for cold formed steel framing
- Designed to facilitate quicker, more cost-effective installation, while making proper attachment of cold formed steel members easier

GenieClip



- Engineered for superior acoustical performance in reducing the transmission of airborne and impact sound through wall and floor/ceiling assemblies
- Easy and fast to install using standard steel furring channel

QuickFrame
Rough Opening System

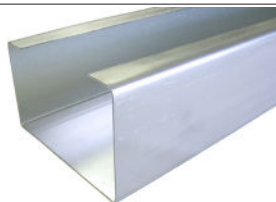

- Eliminates the need for multiple piece headers, jams, and sills, reducing jobsite labor assembly time by more than 50%

YOUR SUCCESS DEPENDS ON QUALITY BUILDING PRODUCTS AND SO DOES OURS.

For over 30 years, Marino\WARE[®], a division of Ware Industries Inc., has served our customers with top quality cold-formed steel framing products, while delivering better solutions to design and construction challenges. We are committed to providing a superior customer experience through a vast selection of readily available products, a knowledgeable sales team, comprehensive technical support and services, prompt delivery through our fleet of trucks, and an extensive distribution network.

Our best-in-class product development team delivers innovative solutions to installation and cost challenges with products designed to save time, labor, and materials. In addition, we utilize the latest in roll forming techniques, maintain the latest level of technology available to the steel framing industry, and strictly adhere to all ASTM specifications.

Marino\WARE is 100% American-owned and operated. We take pride in creating local jobs, supporting local communities, and manufacturing products that reflect the uncompromising skill and ethics of our professional team. We operate state-of-the-art production facilities in New Jersey, Georgia, and Indiana, as well as a sales office in New York.

Visit MarinoWARE.com to experience our full line of innovative solutions.

For more information, please contact Marino\WARE[®] Technical Services at 866.545.1545

This technical information reflects the most current information available and supersedes any and all previous publications effective July 10, 2024 | MW_Shaftwall_ASW_Catalog | © WARE Industries, Inc. 2024

Marino\WARE[®] operates state-of-the-art production facilities in New Jersey, Georgia, and Indiana, as well as a sales office in New York.

New Jersey Facility
400 Metuchen Road
South Plainfield, NJ 07080
800.627.4661
908.757.9000
Fax: 908.412.1442

Georgia Facility
777 Greenbelt Parkway
Griffin, GA 30223
800.504.8199
678.688.1312
Fax: 678.688.1379

Indiana Facility
4245 Railroad Avenue
East Chicago, IN 46312
866.636.6002
219.378.7100
Fax: 219.378.7106

New York Sales Office
51 John St. Ste. 1
Babylon, NY 11702
800.627.4667
631.691.2200
Fax: 631.691.1492

Marino\WARE[®] DesignGroup[™]
100 Hendrick Drive, Suite
200
McDonough, GA 30253
866.545.1545
678.688.7780
Fax: 770.507.2605