



COILED STRAP (CS)

CS are continuous utility straps which can be cut to length on the job site. Packaged in lightweight (about 40 pounds) cartons.

MATERIAL: 33 mil (20 ga), 43 mil (18 ga) & 54 mil (16 ga)

FINISH: Galvanized – G90

INSTALLATION:

- Use all specified fasteners.
- Refer to the applicable code for minimum edge and end distances.
- The table shows the maximum allowable loads and the screws required to obtain them. See footnote #1. Fewer screws may be used; reduce the allowable load by the code lateral load for each fastener subtracted from each end.

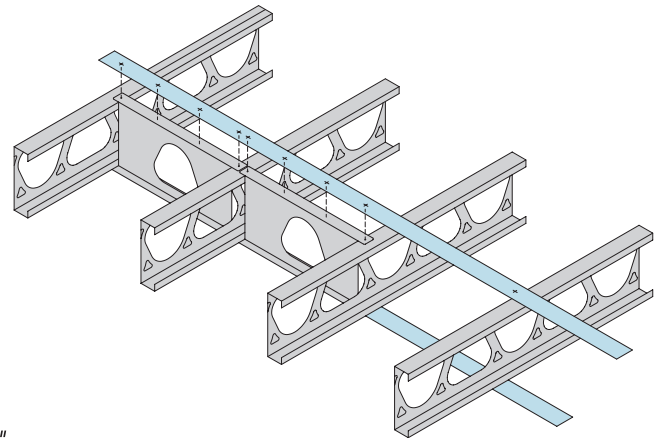

Typical CS installation

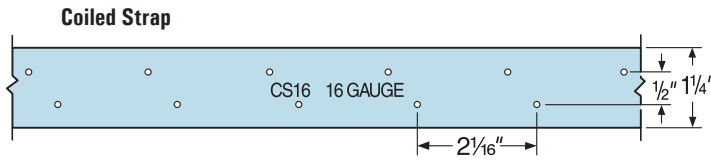

Model No.	Length	Material Thickness (mil/ga)	Width	Fasteners (Total) Rafter/Stud/Joist Thickness			Allowable Tension Loads 33 mil (20ga), 43 mil (18ga) & 54 mil (16ga)	
				33 mil (20ga)	43 mil (18ga)	54 mil (16ga)	(100)	(133)
CS16	150'	54 (16ga)	1-1/4"	18 -#10	12 -#10	8 -#10	1550	2560
CS18	200'	43 (18ga)	1-1/4"	14 -#10	10 -#10	6 -#10	1235	4015
CS20	250'	33 (20ga)	1-1/4"	12 -#10	8 -#10	6 -#10	945	2665

- Notes:
1. Use half of the fasteners in each member being connected to achieve the listed loads.
 2. For CS straps: End Length (inches) = 1/2 total fasteners + 1".
 3. Total Cut Length = End Length + Clear Span + End Length.
 4. For a reduced number of screws, allowable load = (#screws used/#screws in table) x table load.
 5. Loads are based on lesser of steel strap capacity and 2001 AISI NASPEC fastener calculation.
 6. Tabulated loads shown at (100) do not include steel stress increase. Tabulated loads shown at (133) include a 1/3 stress increase on the steel.



SBR & DBR SPACER BRACERS

Simpson Strong-Tie introduces the SBR and DBR spacer bracers for cold-formed steel construction. These spacer bracers reduce the installed cost of cold-formed steel stud walls by enabling faster stud layout while minimizing the need for bridging clips.

MATERIAL: SBR/43 — 43 mil (40 ksi); DBR/30 — 27 mil (33 ksi)

FINISH: Galvanized (G90)

INSTALLATION:

- Spacer-bracers are fed through the stud knockout at a 90-degree angle until studs align with spacer-bracer slots. With the slots engaging the stud web, the spacerbracer is then rotated back to the flat position so that the slotted flanges are on the bottom.
- For off-layout or end-of-run studs where a spacerbracer slot does not engage a stud, manually snip the spacerbracer flanges with a 1/2" deep slot and secure the spacer bracer to the stud with Simpson Strong-Tie LSSC or RCA connectors. Use all specified fasteners.
- Wear gloves while handling and installing spacer bracers.

