

# Marino\WARE® Product Submittal Data

## MARINO\WARE PART # 3T1000 Deflex Clip

**MATERIAL:** 16 ga (54 mil) 50ksi  
**FINISH:** Galvanized – G90  
**SCREWS:** #14 Shouldered screws Inc.

Part No.	Ga/Mil	Yield	Finish
3T1000	16ga (54)	50 KSI	G-90

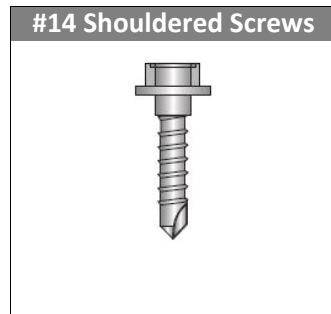
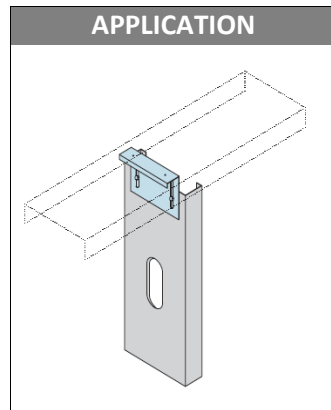
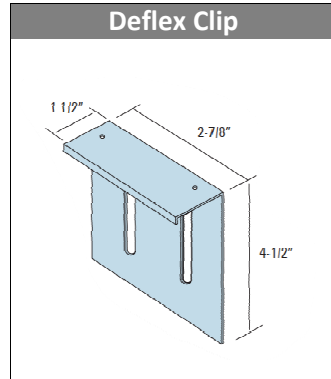

Connection to Structure Hilti 0.145" X-EDNI Powder Actuated Fastener in 3/16" Steel					Connection to Structure #12-14 Hilti kwik Pro Self Drilling Screws to 3/16" Steel						
		3T1000		6T1000				3T1000		6T1000	
Ga (Mil)	No. of Screws	No. of Anchors	Allowabl e Load	Allowabl e Load	Ga (Mil)	No. of Screws	No. of Anchors	Allowabl e Load	Allowable Load (lbs.)		
20 ga. (33) 33ksi	2	2	224	276	20 ga. (33) 33ksi	2	2	278	278		
		3	228	276			3	278	278		
18 ga (43) 33ksi	2	2	224	413	18 ga (43) 33ksi	2	2	410	413		
		3	228	413			3	410	413		
16 ga. (54) 33ksi	2	2	224	413	16 ga. (54) 33ksi	2	2	455	580		
		3	228	440			3	495	580		
16 ga. (54) 50ksi	2	2	224	413	16 ga. (54) 50ksi	2	2	455	685		
		3	228	440			3	495	742		
14 ga. (68) 50ksi	2	2	224	413	14 ga. (68) 50ksi	2	2	455	685		
		3	228	440			3	495	1150		

### NOTES

- All anchors must be attached in a single file line down the center of the clip.
- All anchor data is from the Hilti 2006 Product Technical Guide.
- All anchors must be attached to structure per manufacturer's instructions.
- Anchor edge distance to be 1/2" min.

### CODES & STANDARDS

- Steel meets ASTM A1003
- Coating meets ASTM A1003, A653

### GREEN INFO

- LEED v4 credits available
- Contact Technical Services for more information



For more information, please contact Marino\WARE Technical Services at 866-545-1545.

This technical information reflects the most current information available and supersedes any and all publications, effective 10/1/2021  
 © Copyright 2021 by Ware Industries, Inc. All rights reserved