

Product Description

MarinoWARE HOTROD Type-X is a compressible intumescent firestopping that provides 1 and 2 hour fire-ratings for both dynamic and static joints according to UL-2079 5th edition on both concrete and fluted decks without spray over mineral wool (for both standard walls and shaft walls) and is sound tested according to ASTM E90, tested up to a STC 68.

- **HOTROD** has a rectangular profile and is easily compressed into the deflection gap between the edge of the drywall and adjoining structure.
- **HOTROD** is red in color and is easily identified by the inspector.
- **HOTROD** may be used with CEMCO Spray-less Flute Clips in a perpendicular to flute wall assembly.
- **HOTROD** is non-wicking as it does not wick water, and is non-hygroscopic. HOTROD will not absorb water readily under field conditions.
- **HOTROD** takes the place of BOTH fire and sound sealant and will not shrink, pull away, or harden over time.
- **HOTROD** can be installed by itself or can be covered with tape and joint compound for exposed walls.
- **HOTROD** provides BOTH 1 and 2 hour fire ratings with both 1/2" x 1" and 1" x 1" profiles.
- **HOTROD** provides an L-rating Less Than 1 CFM/Lin Ft for ambient and 400 degrees F.

Once installed per the appropriate UL report and manufacturers guidelines the HOTROD's intumescent material will not breakdown, and will provide consistent fire protection for the sustainable life of the assembly.

Packaging

- 4'-0" lengths; 1/2" x 1" 20 pieces per box; 1" x 1" 10 pieces per box, 30 boxes per pallet.
- When properly stored indoors, and in original packaging HOTROD will not breakdown and has no expiration date.

ASTM & Code Standards

- ASTM E 1966: Standard Test Method of Fire Tests of Firestop Systems – **UL 2079 5th Edition** Tests For Fire Resistance of Building Joints.
- ASTM E-119 Standard Test Methods for Fire Tests of Building Construction and Material – Sound Tested in accordance with ASTM E90-09 – Air leakage tests conducted for compliance with Section 713.6 of IBC and CBC.
- UL ER25033-01
- Intumescent Firestopping tested per ASTM E 84 UL723, Flame Spread 5, Smoke Index 5.
- UL listings/approvals – HW-D-0624; HW-D-0625; HW-D-0554; HW-D-0550; BW-S-0024; WW-D-0104; WW-S-0057; HW-D-0514; HW-D-0518; HW-D-0524; HW-D-0652; HW-D-0620; HW-D-0573; HW-D-0525; HW-D-0553; HW-D-0621; WW-S-0094; HW-D-0596; HW-D-0554; HW-D-0551.
- IBC: 2012, 2015, 2018, 2021
- CBC: 2013, 2016, 2019
- AISI: S100, S220
- **U.S. Patent No. 9,683,364; 10,184,246; and 11,060,283**

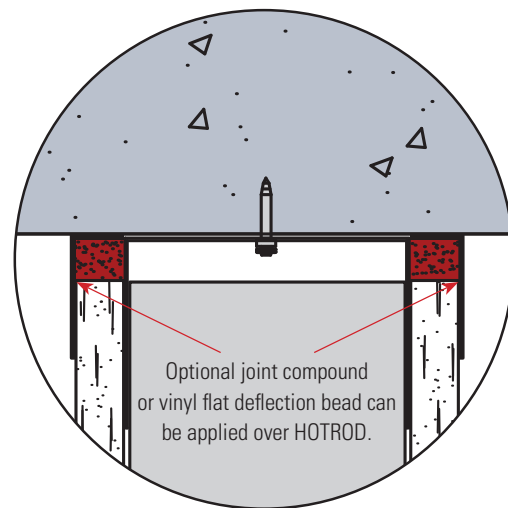
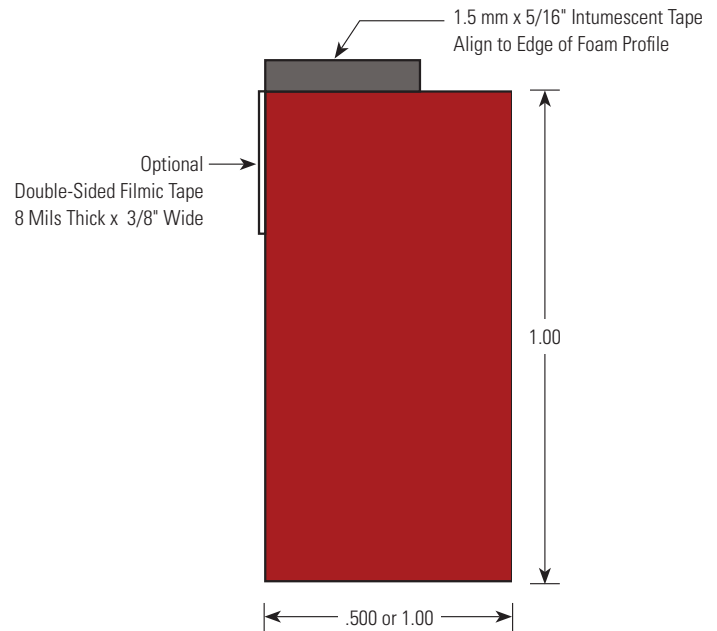

← Scan or click the code to view the installation video!



For more information, please contact MarinoWARE® Technical Services at 866.545.1545

This technical information reflects the most current information available and supersedes any and all previous publications effective December 7, 2023 | MW-Joint Firestopping Catalog | ©WARE Industries, Inc. 2023