

Design/System/Construction/Assembly Usage Disclaimer

- Authorities Having Jurisdiction should be consulted in all cases as to the particular requirements covering the installation and use of UL Certified products, equipment, system, devices, and materials.
 - Authorities Having Jurisdiction should be consulted before construction.
 - Fire resistance assemblies and products are developed by the design submitter and have been investigated by UL for compliance with applicable requirements. The published information cannot always address every construction nuance encountered in the field.
 - When field issues arise, it is recommended the first contact for assistance be the technical service staff provided by the product manufacturer noted for the design. Users of fire resistance assemblies are advised to consult the general Guide Information for each product category and each group of assemblies. The Guide Information includes specifics concerning alternate materials and alternate methods of construction.
 - Only products which bear UL's Mark are considered Certified.
-

BXUV - Fire Resistance Ratings - ANSI/UL 263 Certified for United States

BXUV7 - Fire Resistance Ratings - CAN/ULC-S101 Certified for Canada

[See General Information for Fire-resistance Ratings - ANSI/UL 263 Certified for United States Design Criteria and Allowable Variances](#)

[See General Information for Fire Resistance Ratings - CAN/ULC-S101 Certified for Canada Design Criteria and Allowable Variances](#)

Design No. **V457**

April 19, 2022

Bearing Wall Ratings - 1, 2, and 3 Hr (see item 5)

For Interior Walls – Ratings Applicable for Exposure to Fire on Both Faces (See item 5)

For Exterior Walls - Ratings Applicable For Exposure To Fire On Interior Face Only - (See Items 5 and 7).

For Exterior Walls - 2 Hr. Rating Applicable For Exposure to Fire on Exterior Side – (See items 5, 7 and 7a)

*** Indicates such products shall bear the UL or cUL Certification Mark for jurisdictions employing the UL or cUL Certification (such as Canada), respectively.**

Interior Wall – Fire exposed to either face

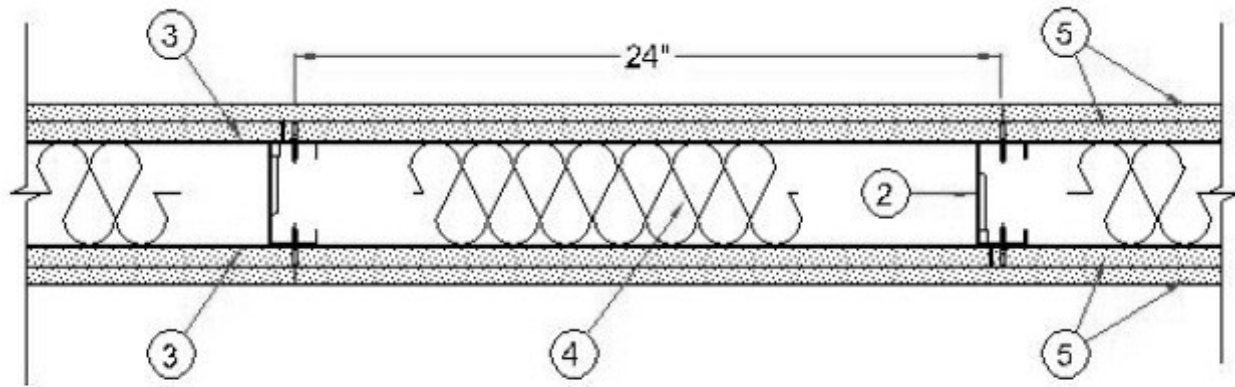

HORIZONTAL SECTION

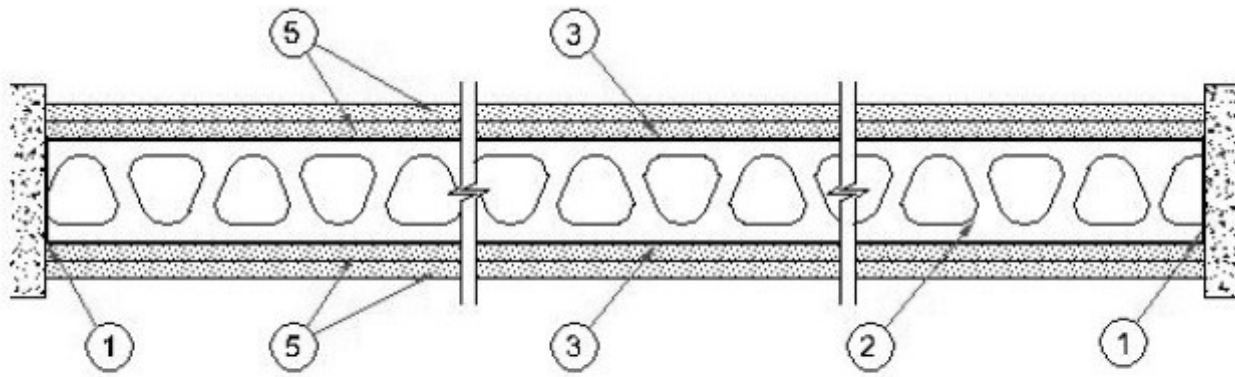

VERTICAL SECTION

Exterior Wall – Fire exposed to the exterior

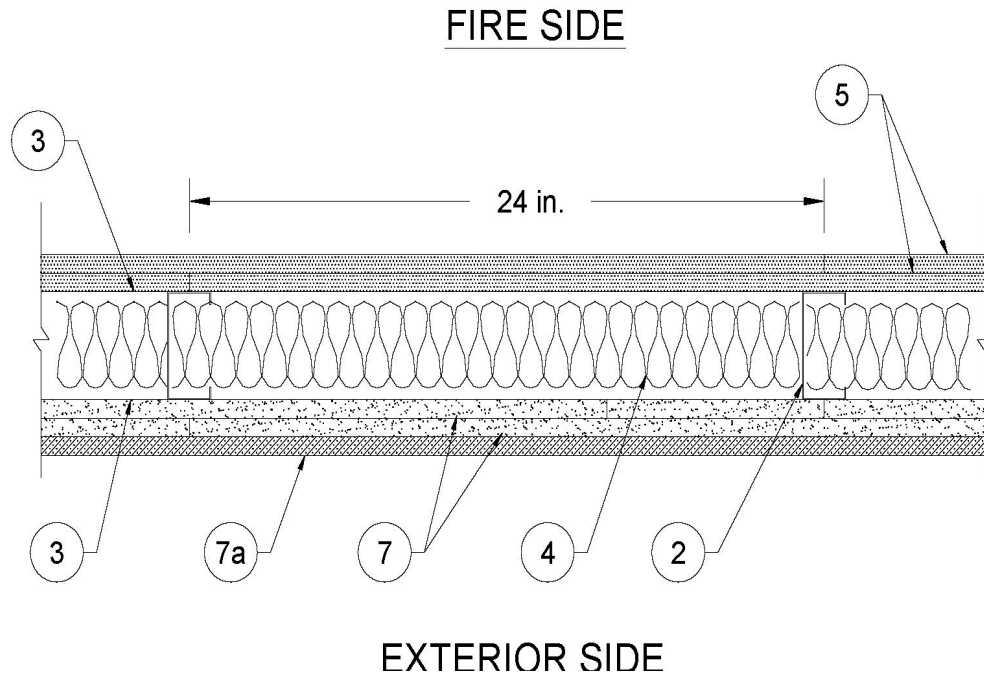

1. **Floor and Ceiling Track** — Min 3-5/8 in. wide by 1-1/4 in. deep channel, min No. 18 MSG galvanized steel, attached to masonry or concrete with fasteners spaced 24 in. OC.

2. **Structural Steel Member*** — Min 3-5/8 in. wide, 1-5/8 in. deep, steel studs made from min 20 MSG galvanized steel. Studs spaced 24 in. OC (maximum) and attached to floor and ceiling track with No. 8 by 1/2 in. long low profile screws, one screw per flange, each side.

MARINO/WARE, DIV OF WARE INDUSTRIES INC — Type JR StudRite studs, Type JT Stud Track

3. **Lateral Bracing** — 1-1/2 in. wide 18 GA thick galvanized steel strapping, spaced 48 in. OC (maximum) attached to each stud through the flange with one No. 8 by 1/2 in. long low profile screw.

4. **Batts and Blankets*** — Placed in stud cavities, nominal thickness 3-1/2 in., any glass fiber insulation bearing the UL Classification Marking as to Surface Burning Characteristics and/or Fire Resistance, having a min density of 1.0 pcf. See **Batts and Blankets** (BKNV and/or BZJZ) Categories for names of Classified Companies.

5. **Gypsum Board*** — 5/8 in. thick, 48 in. wide applied in one, two, or three layers on each side of stud in accordance with the following:

Rating	No. of Layers, Each Side	% of Design Load
1 hour	1 layer, 5/8 in. thick	100
2 hour	2 layers, 5/8 in. thick	100
3 hour	3 layers, 5/8 in. thick	100

Single layer, double layer, or triple layer construction applied vertically and attached to studs and track with 1 in. long Type "S" drywall screws spaced 12 in. OC along board edges and ends and in the field of the board. Joints located over studs and staggered on opposite sides of the assembly. Outer layer of double layer construction applied horizontally or vertically and attached to studs and track with 1-5/8 in. long Type "S" drywall screws spaced 12 in. OC along board edges and ends and in the field of the board. Outer layer of triple layer construction applied horizontally or vertically and attached to studs and track with 2-1/4 in. long Type "S" drywall screws spaced 12 in. OC along board edges and ends and in the field of the board. Vertical joints located over studs, vertical and horizontal joints staggered from inner layer joints and on opposite sides of the assembly.

AMERICAN GYPSUM CO — Type AG-C

CGC INC — Types C, IP-X2, IPC-AR, WRC, ULIX

CERTAINTED GYPSUM INC — Type LGFC-C/A

GEORGIA-PACIFIC GYPSUM L L C — Types 5, Fireguard C, GPFS1, TG-C

NATIONAL GYPSUM CO — Type FSW-C

UNITED STATES GYPSUM CO — Types C, IP-X2, IPC-AR, WRC, ULIX

USG BORAL DRYWALL SFZ LLC — Type C

USG MEXICO S A DE C V — Types C, IP-X2, IPC-AR, WRC

6. **Joint Tape and Compound** — (Not Shown) — Outer layer joints covered with joint compound and paper or mesh tape. Screw heads covered with joint compound.

7. **Gypsum Sheathing** — When used for exterior wall, 5/8 in. thick Classified or unclassified exterior gypsum sheathing may be used on the exterior side of the wall in combination with, or in lieu of, gypsum board (item 5) when the fire exposure is from the interior side only (see Item 5 Table for number of layers required). When used in lieu of item 5 on the exterior side, sheathing is applied vertically and attached to studs and runner tracks with 1 in. long, 1-5/8 in. long, or 2-1/4 in. long Type S-12 bugle head screws spaced 12 in. OC. along studs and tracks for 1 layer, 2 layers, or 3 layers. When used in combination with gypsum board (item 5), fastener length must allow a minimum 3/8 in. penetration into steel structural member. One of the following exterior facings are to be applied over the gypsum sheathing.

a. **Brick Veneer - (Not shown)** — Solid brick veneer attached to studs over gypsum sheathing and meeting the requirements of local code agencies. When a min 3-3/4 in. thick brick veneer facing is used and a minimum of 2 layers of gypsum board and/or sheathing (see item 7) is used on each side, the Exterior Wall Rating is 2 hrs when exposed to fire on the exterior side of the wall. Brick veneer wall attached to studs with corrugated metal wall ties attached to each stud with steel screws, not more than each sixth course of brick. When a min 3-3/4 in. thick brick veneer facing is used, Foamed Plastic (Item 10) may be used.

b. **Cementitious Backer Units* — (Not shown)** - 1/2 or 5/8 in. thick, square edge boards, attached to steel studs over gypsum sheathing with 1-5/8 in. long (over 1 layers of gypsum board), or 2-1/4 in. long (over 2 layers of gypsum board), Type S-12, corrosion resistant, wafer head steel screws, spaced 8 in. OC. Studs spaced a max of 16 in. OC. Joints covered with glass fiber mesh tape.

UNITED STATES GYPSUM CO — Type DCB

c. **Fiber-Cement Siding — (Not shown)** - Fiber-cement exterior sidings including smooth and patterned panel or lap siding.

d. **Molded Plastic* — (Not shown)** - Solid vinyl siding mechanically secured to framing members in accordance with manufacturer's recommended installation details.

ALSIDE, DIV OF ASSOCIATED MATERIALS INC

e. **Wood Structural Panel or Lap Siding — (Not shown)** - APA Rated Siding, Exterior, plywood, OSB or composite panels with veneer faces and structural wood core, per PS 1 or APA Standard PRP-108, including textured, rough sawn, medium density overlay, brushed, grooved and lap siding.

f. **Aluminum or steel siding – (Not shown)** - Attached to studs over gypsum board or sheathing and meeting the requirements of local code agencies.

g. **Stucco –(Not shown)** - Attached to studs over gypsum board or sheathing and meeting the requirements of local code agencies.

*** Indicates such products shall bear the UL or cUL Certification Mark for jurisdictions employing the UL or cUL Certification (such as Canada), respectively.**

Last Updated on 2022-04-19

The appearance of a company's name or product in this database does not in itself assure that products so identified have been manufactured under UL Solutions' Follow - Up Service. Only those products bearing the UL Mark should be considered to be Certified and covered under UL Solutions' Follow - Up Service. Always look for the Mark on the product.

UL Solutions permits the reproduction of the material contained in Product iQ subject to the following conditions: 1. The Guide Information, Assemblies, Constructions, Designs, Systems, and/or Certifications (files) must be presented in their entirety and in a non-misleading manner, without any manipulation of the data (or drawings). 2. The statement "Reprinted from Product iQ with permission from UL Solutions" must appear adjacent to the extracted material. In addition, the reprinted material must include a copyright notice in the following format: "©2024 UL LLC."