

PRODUCT CATALOG



**QuickFrame**  
Rough Opening System

**MARINO WARE®**

The QuickFrame™ Rough Opening System streamlines installation by reducing the number of components required to frame windows and doors. The QuickFrame™ system comes in extra wide flanges and extra long returns and can be used for exterior or interior framing around any non-load bearing opening. Simply attach the header and jamb with our QuickFrame™ Clip for “quick” and easy installation.

- INCREASED PERFORMANCE
- LESS MATERIAL WEIGHT AND PIECES
- 50% REDUCTION IN ASSEMBLY TIME
- ELIMINATING BUILT-UP JAMBS AND HEADERS
- PREDRILLED HOLES IN THE CLIP FOR EASY INSTALLATION

*QuickFrame Identification System  
(in compliance with SSMA)*

**600-QFH-300-54**

**600-QFJ-300-54**

- Member Width 6" = 600 x 1/100 in.
- Style: QF = QuickFrame Header/Jamb
- Flange Width: 3" = 300 x 1/100 in.
- Material Thickness: Minimum Base Metal Thickness: 0.054 in. = 54 mils (1 mil = 1/1000 in.)

## SYMBOLS AND DEFINITIONS

### Gross Properties

$I_x$	Moment of inertia about x-axis
$S_x$	Section modulus about x-axis
$r_x$	Radius about x-axis
$I_y$	Moment of inertia about y-axis
$r_y$	Radius about y-axis

### Effective Properties

$I_{xe}$	Moment of inertia about x-axis
$S_{xe}$	Section modulus about x-axis
$M_a$	Allowable moment for track and channel sections based on local buckling
$V_{ag}$	Allowable strong axis shear away from punchout, per AISI Section C3.2.1
$V_{anet}$	Allowable strong axis shear at punchout, per AISI Section 3.2.2

### Torsional and other Properties

J	Saint-Venant torsion constant. The values shown in the tables have been multiplied by 1,000. To obtain the actual values, divide table values by 1,000
$C_w$	Torsional warping constant
$x_o$	Distance from shear center to centroid along principal x-axis
$r_o$	Polar radius of gyration about shear center
$\beta$	$1 - (x_o / r_o)^2$

## APPLICATIONS

### QuickFrame Header and Jamb:

- Exterior Curtain-Wall Headers and Jambs.
- Interior Non-Load Bearing Headers and Jambs.
- Load Bearing Jambs.

### Notes:

1. Header must be ordered ½" shorter to accommodate the QuickFrame Clip.
2. For header application use unpunched material.

## CODES AND STANDARDS

- ASTM A1003 and A653 - Material Specification
- ASTM C955, AISI S240 - Product and Coating Specification

## PRODUCT DATA

### QuickFrame Header and Jamb:

- Available Widths: 3-5/8", 4", 6" and 8"
- Available Flanges: 3" and 3-1/2"
- Return Lip: 1"

### QuickFrame Clip:

- Available Lengths: 3-1/2" (for 3-5/8" stud)  
3-7/8" (for 4" stud)  
5-7/8" (for 6" stud)  
7-7/8" (for 8" stud)
- Available Heights: 3-1/8" (for 3" flange header)  
3-5/8" (for 3-1/2" flange header)

## MATERIAL SPECIFICATIONS

### QuickFrame Header and Jamb:

- Available Thickness's: 33 mils (20 Gauge)  
43 mils (18 Gauge)  
54 mils (16 Gauge)  
68 mils (14 Gauge)  
97 mils (12 Gauge)  
118 mils (10 Gauge)
- Yield Strength: 50 ksi
- Coating: G60 standard  
G90 available upon request

### QuickFrame Clip:

- Available Gauge: 68 mils (14 Gauge)
- Yield Strength: 50 ksi
- Coating: G90 standard

## Warrenty & Limitations

All products presented herein are warranted to the buyer to be free from defects in material and workmanship. The foregoing warranty is non-assignable and in lieu of and excludes all other warranties not expressly set forth herein, whether express or implied by operation of law or otherwise, including but not limited to any implied warranties of merchantability or fitness for a particular purpose. All details and specifications presented herein are intended as a general guide for the use of Marino\WARE® framing systems. These products should not be used without evaluation by a qualified engineer or architect to determine their suitability for a specific use.

Marino\WARE® assumes no responsibility for failure resulting from use of its details or specifications, or for failure resulting from improper application or installation of these products.

## Governing Law

All issues arising in connection with your order and all transactions associated with it shall be interpreted according to the laws of the State of New Jersey, and all actions or other proceedings arising out of such issues shall be brought only in Superior Court, State of New Jersey, County of Essex, or United States District Court for the District of New Jersey. No action may be brought more than one year after accrual of the cause of action therefore.

The complete QuickFrame System is available through all MarinoWARE suppliers and components can be used separately or together with all MarinoWARE framing solutions. For more information visit [www.MarinoWare.com](http://www.MarinoWare.com).

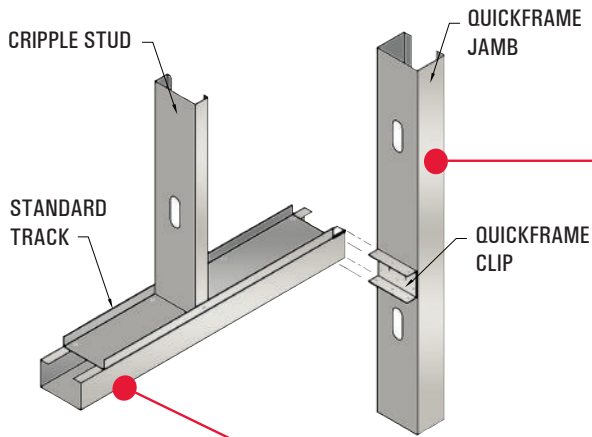

**QUICKFRAME JAMB**

- Replaces built-up headers & jamps
- One header eliminates multiple pieces
- Pre-cut to length
- Equal or greater in strength than traditional multiple piece assemblies
- Reduced assembly time up to 50%

**QUICKFRAME HEADER**

**QUICKFRAME CLIP**

- Simple one piece clip
- Pre-drilled holes for easy installation
- Available in 14 gauge with 3" and 3 1/2" flange
- Prefabricated slots to ease adjustments

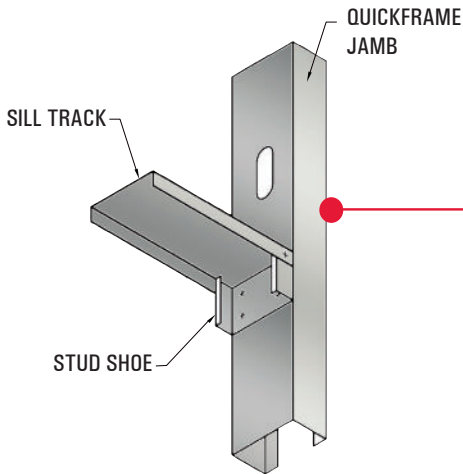
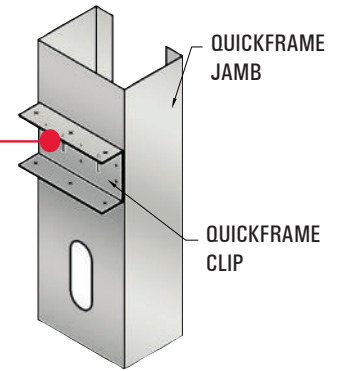

**SILL & QUICKFRAME JAMB**

- One sill track eliminates multiple pieces
- Pre-cut to length
- Works with larger openings
- Reduced assembly time up to 50%

**QUICKFRAME JAMB**

- Replaces built-up jamb
- Pre-cut to length
- Equal or greater in strength than traditional multiple piece assemblies
- Reduced assembly time up to 50%

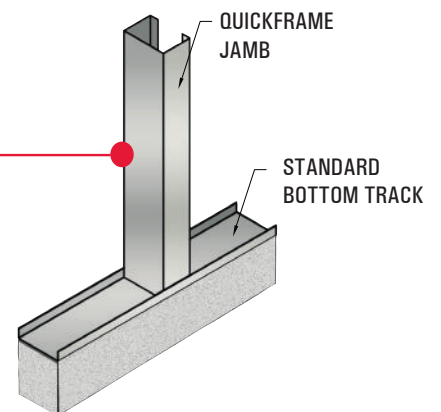

Table with columns: Member Physical Properties, Gross Section Properties, Effective Section Properties, Torsional Properties. Rows are categorized by member size: 3 5/8", 4", 6", and 8" Members.

Notes:
1. Tables are based on AISI S100.
2. 33 and 43 mil we use Direct Strength Method (DSM).



The QuickFrame Clip (QFC) is a 14 gauge (68 mil) U-shaped clip is designed to attach the QuickFrame Header to the QuickFrame Jamb.

**Material:** 68 mil (14 gauge), 50 ksi

**Finish:** Galvanized G90

**Installation:**

- Attach the QuickFrame clip (QFC) with minimum of 4 #10-16 screws to the QuickFrame Jamb (QFJ) and QuickFrame Header (QFH) respectively.

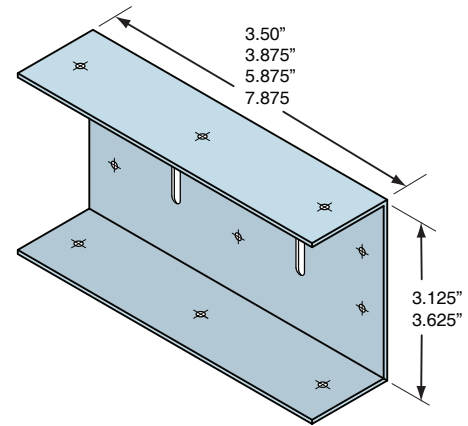

MODEL NO.	GAUGE	DIMENSIONS
QFC362300	14	3 1/2" x 3 1/8"
QFC400300	14	3 7/8" x 3 1/8"
QFC600300	14	5 7/8" x 3 1/8"
QFC800300	14	7 7/8" x 3 1/8"
QFC362350	14	3 1/2" x 3 5/8"
QFC400350	14	3 7/8" x 3 5/8"
QFC600350	14	5 7/8" x 3 5/8"
QFC800350	14	7 7/8" x 3 5/8"

**QFC ALLOWABLE LATERAL LOADS (LBS.)**

QuickFrame Clip	QuickFrame Member			
	54 mil (16 Gauge)	68 mil (14 Gauge)	97 mil (12 Gauge)	118 mil (10 Gauge)
	50 ksi	50 ksi	50 ksi	50 ksi
QFC362300	1,330	1,330	2,160	2,160
QFC400300	1,330	1,330	2,160	2,160
QFC600300	1,490	1,490	2,300	2,300
QFC800300	1,490	1,490	2,300	2,300
QFC362350	1,500	1,500	2,480	2,480
QFC400350	1,480	1,480	2,300	2,300
QFC600350	1,480	1,480	2,300	2,300
QFC800350	1,480	1,480	2,300	2,300

**QFC ALLOWABLE VERTICAL LOADS (LBS.)**

QuickFrame Clip	QuickFrame Member							
	54 mil (16 Gauge)		68 mil (14 Gauge)		97 mil (12 Gauge)		118 mil (10 Gauge)	
	50 ksi		50 ksi		50 ksi		50 ksi	
	0" Gap	1/4" Gap	0" Gap	1/4" Gap	0" Gap	1/4" Gap	0" Gap	1/4" Gap
QFC362300	1,090	948	1,090	948	1,630	1,418	1,630	1,418
QFC400300	1,030	896	1,030	896	1,380	1,200	1,380	1,200
QFC600300	1,030	896	1,030	896	1,380	1,200	1,380	1,200
QFC800300	1,030	896	1,030	896	1,380	1,200	1,380	1,200
QFC362350	940	818	940	818	1,430	1,244	1,430	1,244
QFC400350	940	818	940	818	1,430	1,244	1,430	1,244
QFC600350	1,030	896	1,030	896	1,710	1,488	1,710	1,488
QFC800350	1,030	896	1,030	896	1,710	1,488	1,710	1,488

- Notes:
1. Tabulated values are based on #10-16 screws with ultimate shear capacity of 1,600 lbs per screw.
  2. Allowable loads have not been increased for wind or seismic.
  3. Use the squared interaction equations when QFC subjected to both vertical and lateral loads.
  4. Tabulated vertical loads are limited to max 1/8" vertical displacement of the clip.
  5. Up to 1/4" gap is permitted between the end of QF Header and the QF Jamb. Allowable vertical loads are listed for no gap and 1/4" gap. Linear interpolations is permitted for smaller gaps.

\*1/4" GAP is the distance from the web of the QuickFrame Jamb to the end of the QuickFrame Header  
Use 0" Gap values when the QuickFrame Header is tight against the QuickFrame Clip.

1. QUICKFRAME HEADER CONNECTION

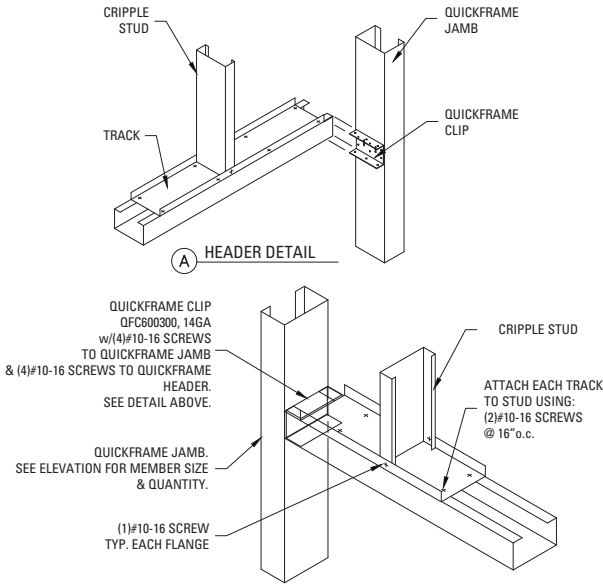

2. JAMB ANCHORAGE

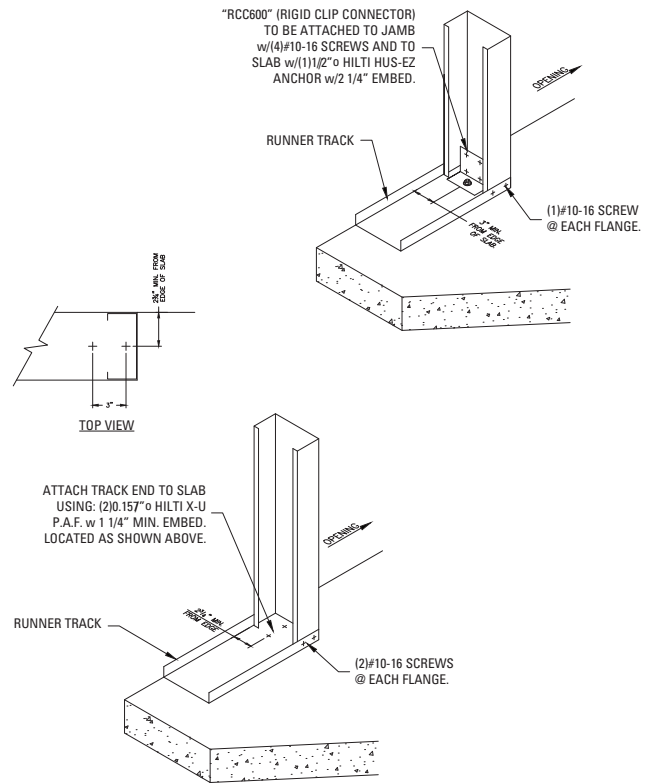

3. QUICKFRAME SILL CONNECTION

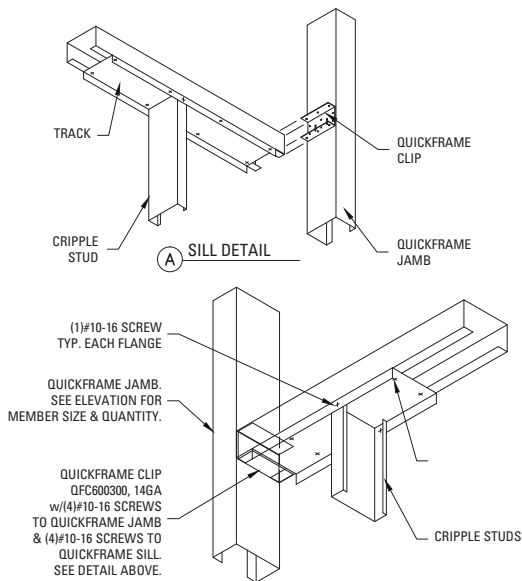

4. SILL TRACK CONNECTION

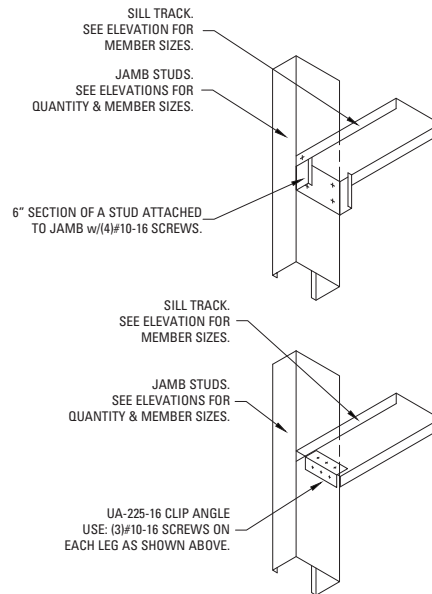

## **YOUR SUCCESS DEPENDS ON QUALITY BUILDING PRODUCTS AND SO DOES OURS.**

For over 30 years, Marino\WARE<sup>®</sup>, a division of Ware Industries Inc., has served our customers with top quality cold-formed steel framing products, while delivering better solutions to design and construction challenges. We are committed to providing a superior customer experience through a vast selection of readily available products, a knowledgeable sales team, comprehensive technical support and services, prompt delivery through our fleet of trucks, and an extensive distribution network.

Our best-in-class product development team delivers innovative solutions to installation and cost challenges with products designed to save time, labor, and materials. In addition, we utilize the latest in roll forming techniques, maintain the latest level of technology available to the steel framing industry, and strictly adhere to all ASTM specifications.

Marino\WARE is 100% American-owned and operated. We take pride in creating local jobs, supporting local communities, and manufacturing products that reflect the uncompromising skill and ethics of our professional team. We operate state-of-the-art production facilities in New Jersey, Georgia, and Indiana, as well as a sales office in New York.

Visit [MarinoWARE.com](http://MarinoWARE.com) to experience our full line of innovative solutions.

**For more information, please contact Marino\WARE<sup>®</sup> Technical Services at 866.545.1545**

This technical information reflects the most current information available and supersedes any and all previous publications effective September 1, 2023 | MW-QuickFrame Catalog | © WARE Industries, Inc. 2023

Marino\WARE<sup>®</sup> operates state-of-the-art production facilities in New Jersey, Georgia, and Indiana, as well as a sales office in New York.

**New Jersey Facility**  
400 Metuchen Road  
South Plainfield, NJ 07080  
800.627.4661  
908.757.9000  
Fax: 908.412.1442

**Georgia Facility**  
777 Greenbelt Parkway  
Griffin, GA 30223  
800.504.8199  
678.688.1312  
Fax: 678.688.1379

**Indiana Facility**  
4245 Railroad Avenue  
East Chicago, IN 46312  
866.636.6002  
219.378.7100  
Fax: 219.378.7106

**New York Sales Office**  
51 John St. Ste. 1  
Babylon, NY 11702  
800.627.4667  
631.691.2200  
Fax: 631.691.1492

**Marino\WARE<sup>®</sup> DesignGroup™**  
100 Hendrick Drive, Suite  
200  
McDonough, GA 30253  
866.545.1545  
678.688.7780  
Fax: 770.507.2605