

Marino\WARE® Product Submittal Data

PRODUCT NAME: 250VS125-30

MARINO\WARE PART # 212VS30



PROPERTIES:

A. Web (in)	2-1/2	Yield Strength Fy (KSI)	33
B. Flange (in)	1-1/4	Design Thickness (in)	0.0312
C. Lip (in)	1/4"	Minimum Thickness (in)	0.0296
Mils	30	Gauge	20 DW
Finish	CP60		

09.22.16 Non-Structural Metal Stud

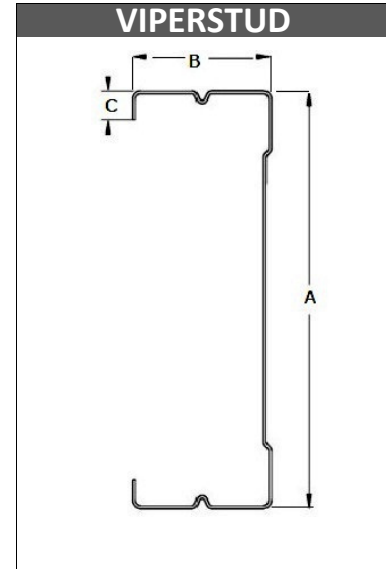

SECTION PROPERTIES

GROSS SECTION PROPERTIES

Weight of Member: (lb/ft)	0.550
Cross Sectional Area: A (in ²)	0.161
Moment of Inertia: Ix (in ⁴)	0.166
Radius of Gyration: Rx (in)	1.020
Gross Moment of Inertia: Iy (in ⁴)	0.032
Gross Radius of Gyration: Ry (in)	0.448

EFFECTIVE SECTION PROPERTIES

Moment of Inertia-Deflection: Ix (in ⁴)	0.163
Section Modulus: Sx (in ³)	0.120

MOMENTS

Allowable Bending Moment: Ma (in-k)	2.310
Local Buckling Nominal Moment: Mnl (in-k)	3.960
Distortional Buckling Moment: Mnd (in-k)	3.860

LIMITING HEIGHTS - COMPOSITE (ft-in)

Spacing (in)	5 psf			7.5 psf			10 psf		
	L/120	L/240	L/360	L/120	L/240	L/360	L/120	L/240	L/360
12	18-9	14-10	13-0	16-4	13-0	11-4	14-10	11-10	10-4
16	17-0	13-6	11-10	14-10	11-10	10-4	13-6	10-9	9-3
24	14-10	11-10	10-4	12-9	10-4	8-10	11-0	9-3	-

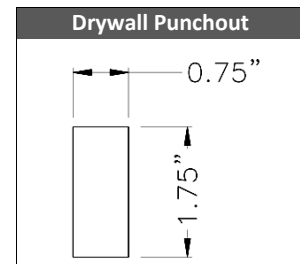

1. Gypsum must be vertically oriented, applied full height to both sides, and fastened to each stud and track flange
2. Acceptable wallboards are 5/8" type X from: USG, National, GP, Pabco, American, Continental & CertainTeed.
3. No screws are required between stud and track, except as required by ASTM C754.
4. See CCRR-0154 for additional information. Review fire related assemblies for any additional requirements

CODES & STANDARDS

- Meets IBC 2015, 2018 & FBC 2020
- ASTM C 645, C 754, E 90, E 119 & AISI S220
- Steel sheet meets ASTM A 1003 or A 653
- Third Party Code Evaluation Report: CCRR-0154
- Multiple Fire Rated Assemblies

GREEN INFO

- LEED v4 credits available
- Contact Technical Services for more information



For more information, please contact Marino\WARE Technical Services at 866-545-1545

This technical information reflects the most current information available and supersedes any and all publications, effective 4/2/22.

©Copyright 2022 by Ware Industries, Inc. All rights reserved