

Member Designator **087F125-43**

Coating CP60

Physical Properties

Design Thickness 0.0451 in
 Mil 43 mil
 Gauge 18 Gauge
 Web Width 1.25 in
 Leg Base 0.50 in
 Height 0.875 in
 Yield Strength 33 ksi

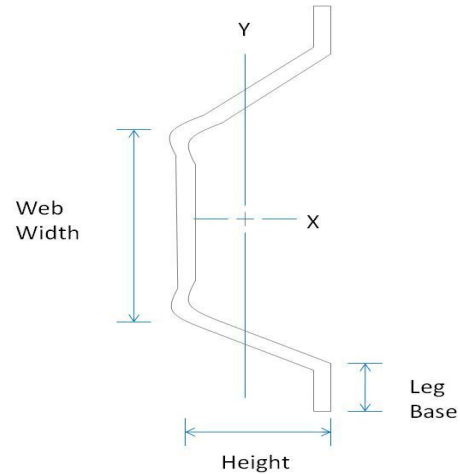

Gross Properties

Gross Properties				
Area (in ²)	I _x (in ⁴)	R _x (in)	I _y (in ⁴)	R _y (in)
0.162	0.020	0.348	0.082	0.711

Effective Properties

Effective Properties ³ (33ksi)		
I _x ² (in ⁴)	S _x (in ²)	M _a (in-k)
0.0196	0.0420	69.17

Allowable Ceiling Spans

Section	Ceiling Span	F _y (ksi)	Spans	4 psf Channel Spacing (in) o.c.			6 psf Channel Spacing (in) o.c.			13 psf Channel Spacing (in) o.c.		
				12	16	24	12	16	24	12	16	24
087F125-43	L/240	33	Single	6' 10"	6' 3"	5' 5"	6' 0"	5' 5"	4' 9"	4' 7"	4' 2"	3' 8"
			Multiple	8' 6"	7' 8"	6' 9"	7' 5"	6' 9"	5' 10"	5' 9"	5' 2"	4' 6"

Section	Ceiling Span	F _y (ksi)	Spans	4 psf Channel Spacing (in) o.c.			6 psf Channel Spacing (in) o.c.			13 psf Channel Spacing (in) o.c.		
				12	16	24	12	16	24	12	16	24
087F125-43	L/360	33	Single	6' 0"	5' 5"	4' 9"	5' 3"	4' 9"	4' 2"	4' 0"	3' 8"	3' 2"
			Multiple	7' 5"	6' 9"	5' 10"	6' 6"	5' 10"	5' 2"	5' 0"	4' 6"	4' 0"

General Notes

- Physical properties and load tables have been calculated in conformance with the 2001 NASPEC for the Design of Cold-Formed Steel Structural Members, including the 2004 Supplement, and the IBC 2006, unless noted otherwise.
- All structural framing members have a protective coating conforming to ASTM C 955.
- Reference ASTM specification A 1003/A 1003 M table 1 for the universe of allowable coatings for light gauge steel framing.
- Stud/joists are manufactured to custom lengths. Stud/joists are manufactured with punched webs unless otherwise specified at time of order.
- Track is produced in standard lengths of 10 feet unless a custom track length is indicated. Track is manufactured with unpunched webs.
- Structural framing members are marked with product information per the requirements of ASTM C 955 section 12.
- All delivered material must be kept dry, preferably by being stored inside a building under a roof. If it is necessary to store material outside, it must be stacked off the ground, properly supported on a level platform, and fully protected from the weather. Reference ASTM C 754 section 8 and ASTM C 1007 section 4.

LEED Green Building Credits

- MR Credit 2: Construction Waste Management – MBA steel framing is 100% recyclable.
 MR Credit 4: Recycled Content – MBA steel framing is formed from no less than 25.5% post-consumer and 6.8% pre-consumer recycled content.
 MR Credit 5: Regional Materials – MBA has manufacturing facilities in multiple states.