

Gold Bond[®]
Building Products

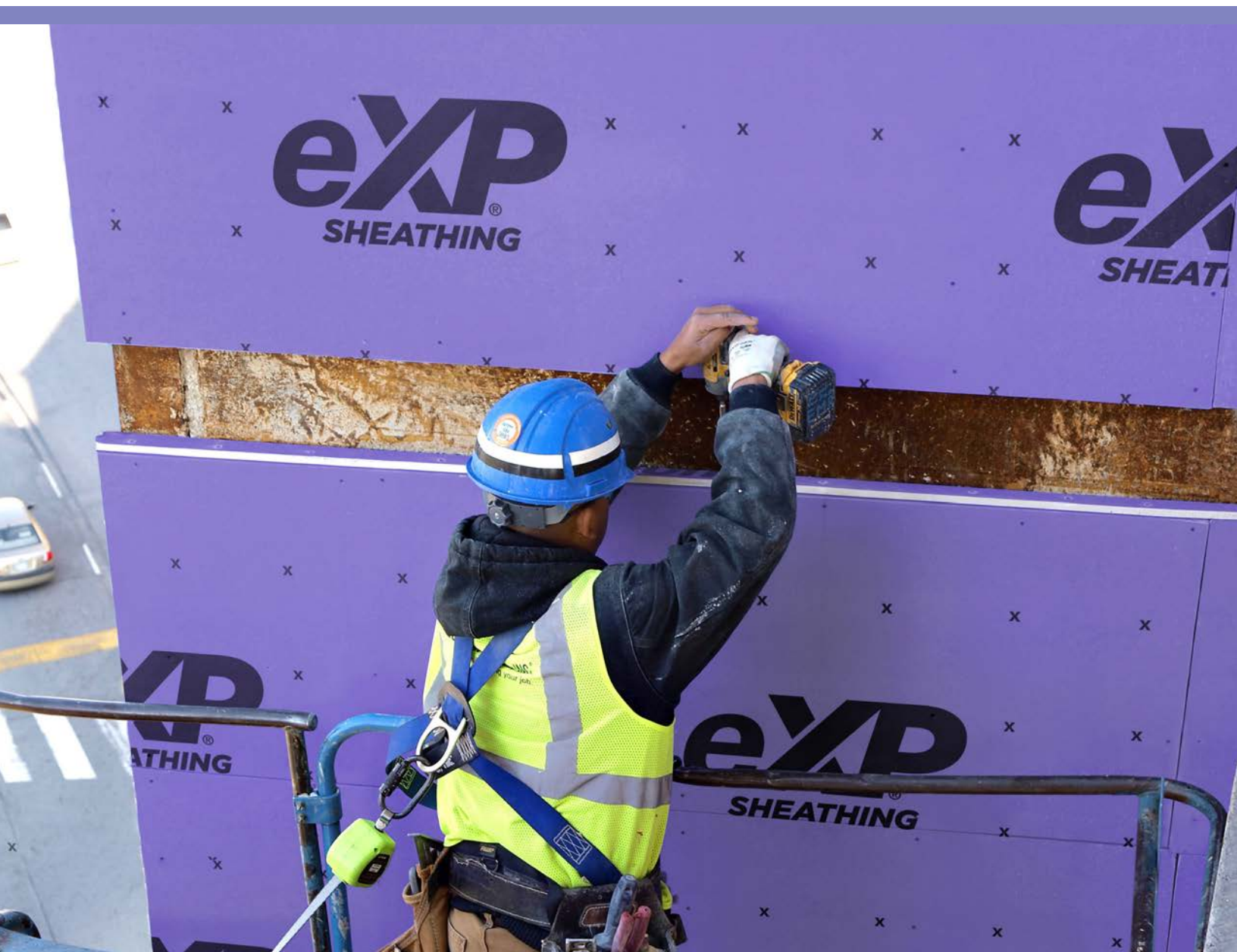

eXP Family of Glass Mat Products

National 
Gypsum[®]

Exclusive service provider of
products manufactured by
Gold Bond Building Products, LLC.



High Performance Products for the Life of the Building

Advanced fiberglass technology

PURPLE eXP® is a technologically advanced fiberglass-faced gypsum line utilizing Sealed Surface Technology. With a solution for most every design or building challenge, our eXP products will help you construct the finest quality interior and exterior walls and ceilings. Our PURPLE coated fiberglass facers provide excellent weather- and water- resistance. Dimensionally stable under changes in temperature and humidity, eXP products resist warping, rippling and buckling.



FIRE RESISTANT

- Approved component in specific UL fire-rated designs.
- Non combustible, fire-resistant material helps protect framing elements, even when cladding is combustible.



MOLD & MOISTURE RESISTANT

- Resists the growth of mold per ASTM D3273 with a score of 10, the best possible score.
- PURPLE coated glass mat provides excellent weather and water resistance. Extraordinarily sturdy, glass mat will stand up to the elements.
- Provides superior water resistance without impeding vapor transmission.



STRENGTH

- Adds structural strength to stabilize structural framing.
- Fiberglass mats integrated into the gypsum core strengthen the panel.
- High performance substrate for weather barrier and cladding systems.



DIMENSIONAL STABILITY

- Dimensionally stable under changes in temperature and moisture conditions. eXP resists warping, rippling and buckling.
- Uniform flexural strength allows panels to be installed vertically or horizontally without sacrificing wall or ceiling strength.
- Long-term protection for the life of the structure.



GRIDMARX®

- Select products feature GridMarX® preprinted fastening guide on the panel to allow for faster and more accurate installation.



EASY TO HANDLE

- Lightweight and easy to handle. It can be cut and fastened with standard drywall tools and fasteners.
- Helps enhance construction schedules and offers long-term protection for the life of the building.
- Sealed Surface Technology is an additional coating on the mat that improves ease of use and enables a cleaner score and snap.



LOW-EMITTING MATERIALS

- Select eXP products achieve UL GREENGUARD Gold Certification. UL GREENGUARD certified products are certified to UL GREENGUARD standards for low chemical emissions into indoor air during product usage. For more information, visit: ul.com/gg.
- Products that achieve UL GREENGUARD Gold Certification qualify as low-emitting per California Specification Section 01350 in accordance with CDPH Standard Method, v1.2. For more information, visit: calrecycle.ca.gov.



Defend Against Mold and More with Advanced Glass Mat Technology

Gold Bond® eXP® is a technologically advanced glass mat gypsum product line utilizing Sealed Surface Technology. Part of our PURPLE family, eXP offers a solution for most every design or building challenge you face. With more moisture and mold resistance, eXP will help you construct the finest quality walls.

Our eXP PURPLE coated glass mat provides excellent weather and water resistance. Extraordinarily sturdy, eXP glass mat will stand up to the elements. Dimensionally stable under changes in temperature, eXP resists warping, rippling and buckling. When you build with our PURPLE eXP products, you will have a single-source solution that provides the performance, support and resources to get the job done right.

1 eXP® INTERIOR EXTREME® GYPSUM PANEL

- For use in all rooms.
- Anywhere mold and moisture is a concern.
- 12-month exposure warranty.

2 eXP® INTERIOR EXTREME® AR GYPSUM PANEL

- Walls subject to added abuse/abrasion.
- Scratch and scuff resistant.
- 12-month exposure warranty.

3 eXP® INTERIOR EXTREME® IR GYPSUM PANEL

- Walls subject to impact from hard objects.
- Resists penetrations through the gypsum board.
- 12-month exposure warranty.

4 eXP® SHAFTLINER

- For use in shafts and stairwells.
- Resists mold and moisture.
- 12-month exposure warranty.

5 eXP® TILE BACKER

- Gypsum backer board for wet areas.
- Acrylic-coated facer.
- Eliminates need for water barrier.

6 eXP® SHEATHING

- Accepts a variety of exterior finishes.
- Finishing of joints not required.
- 12-month exposure warranty.



MEDICAL CENTER



Product Selector



eXP® Sheathing

Use Gold Bond® eXP® Sheathing on the outside of a wall and soffit framing as a substrate for exterior cladding. It is available with either a Regular or Type X gypsum core. eXP Sheathing consists of a moisture- and mold-resistant gypsum core encased in a coated, specially designed PURPLE fiberglass mat on the face, back and sides. The glass mat is folded around the long edges to reinforce and protect the core, and it provides superior weather resistance.

- 1/2" (12.7 mm) / Regular
- 5/8" (15.9 mm) / Type X
- Width: 4' (1,219 mm)
- Length: 8' – 12' (2,438 – 3,658 mm)
- Square Edge
- Features GridMarX® guide marks

ASTM C1177, Federal Specification Number: SS-L-30D Type II Grade X



eXP® Shaftliner

Use Gold Bond® eXP® Shaftliner to construct lightweight fire barriers for cavity shaftwalls (1-4 hr.) and area separation fire walls (2 hr.). eXP Shaftliner consists of a moisture- and mold-resistant gypsum core encased in a coated, specially designed PURPLE fiberglass mat on the face, back and sides. It is available in a Type X core. The glass mat is folded around the long edges to reinforce and protect the core.

- 1" (25.4 mm) / Type X
- Width: 2' (610 mm)
- Length: 8' – 12' (2,438 – 3,658 mm)
- Double Beveled Edge

ASTM C1658, Federal Specification Number: SS-L-30D Type II Grade X



eXP® Tile Backer

Use Gold Bond® eXP® Tile Backer as a substrate for tile applications in high moisture areas, including showers, bathrooms, indoor swimming pools, laundry rooms and kitchens. It is also a code-compliant substrate for tile and other finishes in both wet and non-wet areas, areas of high humidity and fire-rated assemblies (5/8" Type X). It is ideally suited for a variety of interior applications. eXP Tile Backer consists of a moisture- and mold-resistant gypsum core encased in an acrylic-coated, specially designed fiberglass mat on the face, back and sides. It is available in either a Regular or Type X core. The glass mat is folded around the long edges to reinforce and protect the core.

- 1/2" (12.7 mm) / Regular
- 5/8" (15.9 mm) / Type X
- Width: 4' (1,219 mm)
- Length: 8' (2,438 mm)
- Square Edge

ASTM C1178, Federal Specification Number: SS-L-30D Type II Grade X



eXP® Interior Extreme®

Use Gold Bond® eXP® Interior Extreme® Gypsum Panels wherever gypsum board is specified in interior applications for the entire project, installed on wood or metal framing, for increased resistance to incidental moisture. These gypsum panels consist of a moisture- and mold-resistant gypsum core encased in a coated, specially designed fiberglass mat on the face, back and sides. eXP Interior Extreme Gypsum Panels are available in a Regular, Type X or Type C core. The glass mat is folded around the long edges to reinforce and protect the core.

- 1/2" (12.7 mm) / Regular
- 1/2" (12.7mm) / Type C
- 5/8" (15.9 mm) / Type X
- 5/8" (15.9 mm) / Type C
- Width: 4' (1,219 mm)
- Length: 8' – 12' (2,438 – 3,658 mm)
- Tapered Edge
- Features GridMarX® guide marks

ASTM C1658, Federal Specification Number: SS-L-30D Type II Grade X



eXP® Interior Extreme® AR

Use Gold Bond® eXP® Interior Extreme® AR Gypsum Panels for interior applications in areas prone to surface abrasion and indentation, including corridors, entryways, lobby areas and warehouses. These gypsum panels consist of an abuse-, moisture- and mold-resistant gypsum core encased in a coated, specially designed fiberglass mat on the face and back sides. In addition to providing moisture and mold resistance, the AR panel has a denser core and an enhanced glass mat for increased resistance to indentation and abrasion. The glass mat is folded around the long edges to reinforce and protect the core.

- 5/8" (15.9 mm) / Type X
- Width: 4' (1,219 mm)
- Length: 8' – 12' (2,438 – 3,658 mm)
- Tapered Edge
- Features GridMarX® guide marks

ASTM C1658, Federal Specification Number: SS-L-30D Type II Grade X



eXP® Interior Extreme® IR

Use Gold Bond® eXP® Interior Extreme® IR Gypsum Panels for interior applications requiring increased resistance to incidental moisture and wall penetrations. Ideally, use these gypsum panels in areas prone to cavity penetration, including gymnasiums, correctional facilities, schools and workshops. eXP Interior Extreme IR consists of an impact-, moisture- and mold-resistant gypsum core encased in a coated, specially designed fiberglass mat on the face, back and sides. In addition to providing moisture and mold resistance, the IR panel has a denser core and an specially formulated fiberglass mesh embedded into the core for increased resistance to indentation and impact. The glass mat is folded around the long edges to reinforce and protect the core.

- 5/8" (15.9 mm) / Type X
- Width: 4' (1,219 mm)
- Length: 8' – 12' (2,438 – 3,658 mm)
- Tapered Edge
- Features GridMarX® guide marks

ASTM C1658, Federal Specification Number: SS-L-30D Type II Grade X

eXP[®] Sheathing

06 16 00/NGC

Mold and Moisture Resistant with Superior Exposure Capabilities

Specify the Latest Technology

The outer exterior walls and soffits of the building envelope are critical elements that deserve particular attention. Most of these assemblies require sheathing to be attached to the outside of framing as a water-resistant underlayment for various materials. Depending upon where your project is being erected, these assemblies could be exposed to wind, rain, snow and extreme temperatures for extended periods during the construction process and afterward.

With eXP Sheathing Sealed Surface Technology, your project can withstand the elements. For both wood and metal construction, eXP Sheathing provides a solid substrate for various air and water resistive barriers and is a component in Exterior Insulation and Finish Systems (EIFS). With our eXP Sheathing, you'll have built-in weather and fire protection.

eXP Sheathing offers a moisture- and mold-resistant panel with superior extended-exposure capabilities. It is lightweight, handles easily, and is used for a variety of finishes. You'll be hard pressed to find a better sheathing to give your project exactly what it needs – the assurance of a long and productive existence.

Build and Design Better with the Latest Technology

Add structural strength to wood and metal stud construction with Gold Bond eXP Sheathing. Attach eXP Sheathing, a moisture- and mold-resistant gypsum panel, to the outside of sidewall and soffit framing as a water-resistant underlayment for various exterior materials. Apply as a sheathing on wood or steel framing to provide fire resistance and weather protection when used under exterior claddings, including, but not limited to: wood, vinyl, fiber cement siding, masonry veneer, EIFS and stucco. Use eXP Sheathing to achieve fire-rated exterior wall assemblies.





1. Coated Fiberglass Mat
2. Square Edges
3. Enhanced Moisture- and Mold-Resistant Gypsum Core

APPLICATIONS

- Use it as sheathing on wood or steel framing to provide fire resistance and weather protection when used under exterior claddings, such as wood, vinyl and fiber cement siding, masonry veneer, EIFS and stucco.
- Use it as a sheathing in fire-resistance-rated exterior wall assemblies.

Sizes: 1/2" (12.7 mm) Regular and 5/8" (15.9 mm) Fire-Shield® Type X panels are available in 4' (1,219 mm) widths and in standard lengths of 8' (2,438 mm) to 10' (3,658 mm).

ADVANTAGES

PROVIDES FIRE RESISTANCE

- Fire-resistant material with a non-combustible gypsum core helps protect framing elements, even when cladding is combustible.
- Manufactured to meet ASTM C1177 "Standard Specification for Glass Mat Gypsum Substrate for use as Sheathing".

RESISTS MOISTURE AND MOLD

- Provides superior water resistance without impeding vapor transmission.
- Resists the growth of mold per ASTM D3273 with a score of 10, the best possible score.

INSTALLS FAST AND EASY

- Features GridMarX guide marks on the panel to allow for faster and more accurate installation.
- Coated glass mat facers for easy handling.

OFFERS SUPERIOR DURABILITY

- Offers a 12-month extended exposure warranty for typical weather conditions.
- Dimensionally stable under changes in temperature and relative humidity.

WARRANTY & TECHNICAL INFORMATION

Please refer to "Limited Warranty And Remedy" on page 35 for details. For details about fire resistance, technical data and installation recommendations, refer to pages 33-34.

For details about fire resistance, see installation recommendations on page 33.

eXP[®] Sheathing

TECHNICAL DATA

Physical Properties	1/2" eXP Sheathing	5/8" eXP Fire-Shield Sheathing
Thickness¹, Nominal	1/2" (12.7 mm)	5/8" (15.9 mm)
Width¹, Nominal	4' (1,219 mm)	4' (1,219 mm)
Length¹, ⁴, Standard	8' – 12' (2,438 mm – 3,658 mm)	8' – 12' (2,438 mm – 3,658 mm)
Weight, Nominal	1.9 lbs./sq. ft. (9.28 k/m ²)	2.5 lbs./sq. ft. (12.21 k/m ²)
Edges¹	Square	Square
Flexural Strength¹, Perpendicular	≥ 100 lbf. (445 N)	≥ 140 lbf. (623 N)
Flexural Strength¹, Parallel	≥ 80 lbf. (356 N)	≥ 100 lbf. (445 N)
Humidified Deflection¹	≤ 2/8" (6.4 mm)	≤ 1/8" (3.2 mm)
Nail Pull Resistance¹	≥ 80 lbf. (356 N)	≥ 90 lbf. (400 N)
Hardness¹ – Core, Edges and Ends	≥ 15 lbf. (67 N)	≥ 15 lbf. (67 N)
Bending Radius	6' (1,829 mm)	8' (2,438 mm)
Thermal Resistance⁵	R = .43	R = .54
Permeance⁶	22 perms	19 perms
Water Absorption¹ (% of Weight)	≤ 10%	≤ 10%
Linear Expansion with Change Moisture	6.25 x 10 ⁻⁶ /in./%RH	6.25 x 10 ⁻⁶ /in./%RH
Coefficient of Thermal Expansion	9.26 x 10 ⁻⁶ /in./°F	9.26 x 10 ⁻⁶ /in./°F
Racking Strength⁷ (Ultimate – not design value)	> 540 lbs. ft. (732 N/m)	> 654 lbs. ft. (887 N/m)
Mold Resistance⁸, ASTM D3273	Score of 10	Score of 10
Compressive Strength⁹	≥ 500 psi	≥ 500 psi
Product Standard Compliance	ASTM C1177	ASTM C1177
Fire-Resistance Characteristics		
Core Type	Regular	Type X
UL Type Designation	N/A	FSW-6
Combustibility²	Non-combustible core	Non-combustible core
Surface Burning Characteristics³	Class A	Class A
Flame Spread³	0	0
Smoke Development³	0	0
Applicable Standards and References		
ASTM C473 <i>Standard Test Methods for Physical Testing of Gypsum Panel Products</i>		
ASTM C518 <i>Standard Test Method for Steady-State Thermal Transmission Properties by Means of the Heat Flow Meter Apparatus</i>		
ASTM C840 <i>Standard Specification for Application and Finishing of Gypsum Board</i>		
ASTM C1177 <i>Standard Specification for Glass Mat Gypsum Substrate for Use as Sheathing</i>		
ASTM C1280 <i>Standard Specification for Application of Exterior Gypsum Panel Products for Use as Sheathing</i>		
ASTM D3273 <i>Standard Test Method for Resistance to Growth of Mold on the Surface of Interior Coatings in an Environmental Chamber</i>		
ASTM E72 <i>Standard Test Methods for Conducting Strength Tests of Panels for Building Construction</i>		
ASTM E84 <i>Standard Test Method for Surface Burning Characteristics of Building Materials</i>		
ASTM E96 <i>Standard Test Methods for Water Vapor Transmission of Materials</i>		
ASTM E119 <i>Standard Test Methods for Fire Tests of Building Construction and Materials</i>		
ASTM E136 <i>Standard Test Method for Behavior of Materials in a Vertical Tube Furnace at 750°C</i>		
Gypsum Association, GA-214, <i>Levels of Finish for Gypsum Panel Products</i>		
Gypsum Association, GA-216, <i>Application and Finishing of Gypsum Panel Products</i>		
Gypsum Association, GA-238, <i>Guidelines for Prevention of Mold Growth on Gypsum Board</i>		
Gypsum Association, GA-253, <i>Application of Gypsum Sheathing</i>		
Gold Bond Building Products, LLC Manufacturer Standards, <i>NGC Construction Guide</i>		

1. Specified values per ASTM C1177, tested in accordance with ASTM C473.

2. Tested in accordance with ASTM E136.

3. Tested in accordance with ASTM E84.

4. Please consult your local sales representative for all non-standard lengths and widths. Minimum order requirements may apply.

5. Tested in accordance with ASTM C518.

6. Tested in accordance with ASTM E96.

7. Tested in accordance with ASTM E72.

8. Tested in accordance with ASTM D3273 and rated in accordance with ASTM D3274

9. Tested in accordance with ASTM C473, annex X3.

Common eXP® Sheathing Exterior Applications

EIFS

1. eXP® Sheathing
2. Screed Flashing
3. Weather-Resistant Barrier
4. Rigid Insulation
5. Weep Screed
6. Mesh
7. Basecoat
8. Stucco Finish Coat

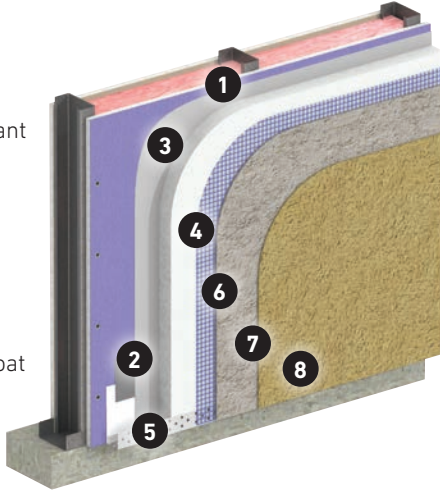

STUCCO

1. eXP® Sheathing
2. Screed Flashing
3. Weather-Resistant Barrier
4. Metal Lath
5. Scratch Coat
6. Weep Screed
7. Brown Coat
8. Primer
9. Stucco Finish Coat

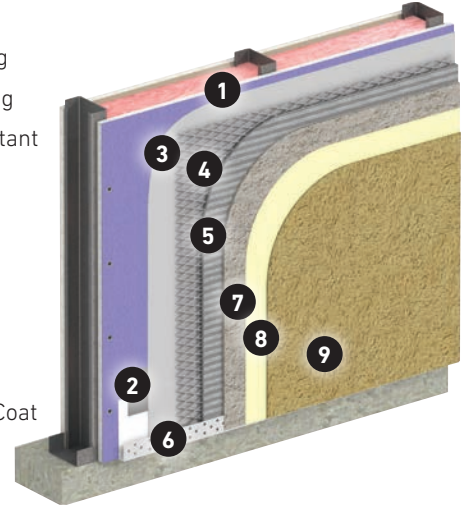

BRICK VENEER

1. eXP® Sheathing
2. Base Flashing
3. Weather-Resistant Barrier
4. Rigid Insulation
5. Veneer Tie
6. Brick Veneer

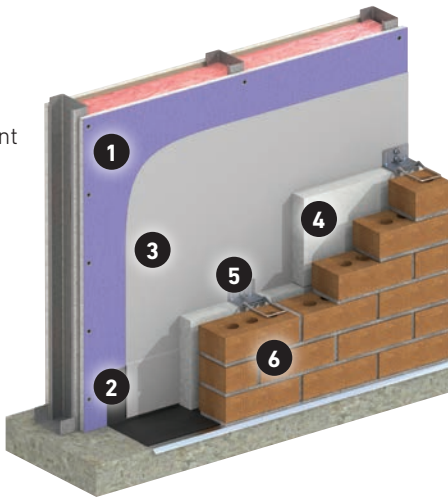

THIN STONE VENEER

1. eXP® Sheathing
2. Weep Screed
3. Base Flashing
4. Weather-Resistant Barrier
5. Rigid Insulation
6. Cement Board
7. Basecoat
8. Thin Stone Veneer

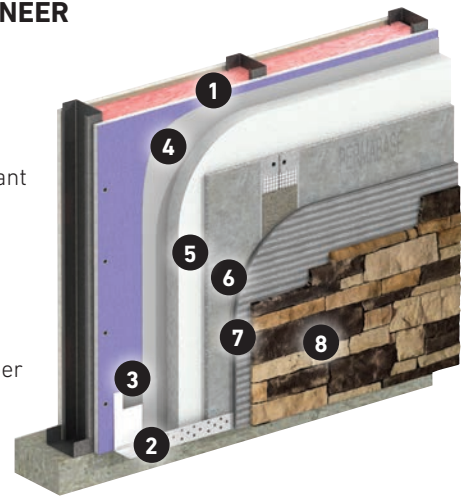

FIBER CEMENT WOOD STUD

1. eXP® Sheathing
2. Base Flashing
3. Weather-Resistant Barrier
4. Drainage Mat
5. Rigid Insulation
6. Furring Strips
7. Lap Siding

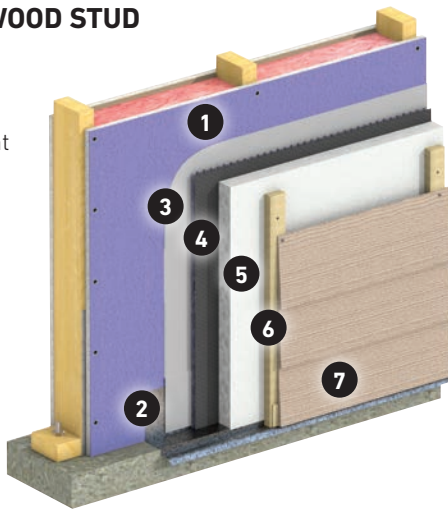

METAL PANEL

1. eXP® Sheathing
2. Base Flashing
3. Weather-Resistant Barrier
4. Drainage Mat
5. Rigid Insulation
6. Furring Strips
7. Horizontal Girts
8. Metal Panel System

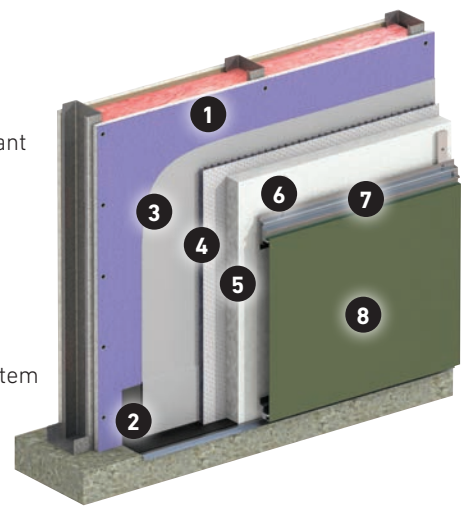

Lightweight Weather Resistant Fire Barrier

Extra Protection Against Inclement Weather

eXP[®] Shaftliner is optimal when constructing lightweight fire barriers for cavity shaftwalls, stairwells and area separation walls in multifamily housing units.

Whether you are constructing multifamily housing or commercial projects, we can help you guard against damaging elements like rain and moisture and ensure you will achieve a fire rating. eXP Shaftliner is a moisture- and mold-resistant shaftliner panel with a fire-resistant (Type X) core. Use eXP Shaftliner panels to construct lightweight fire barriers for cavity shaftwalls (1-4 hr.), stairwells and area separation fire walls (2-3 hr.) in multifamily housing. These panels are key components in the Cavity Shaftwall Systems and the Area Separation Fire Wall Systems. With more multifamily shared walls and questions about structural safety, give yourself peace of mind by specifying eXP Shaftliner.

As with all eXP[®] products, eXP Shaftliner is a moisture- and mold-resistant panel with added fire-resistance. The PURPLE coated fiberglass facers provide excellent weather- and water-resistant capabilities. Dimensionally stable under changes in temperature and humidity, this hard-working panel resists warping, rippling, buckling and sagging. It is specially coated on the front, back and edges for easy installation. eXP Shaftliner can also enhance acoustical performance; again, ideal when you are constructing multifamily residences.





1. Coated Fiberglass Mat
2. Double Beveled Edges
3. Enhanced Moisture- and Mold-Resistant Gypsum Core

APPLICATIONS

eXP® Cavity Shaftwall Systems: These systems enclose elevator, horizontal shafts and chase walls in buildings where it is advantageous to erect these walls from one side only. eXP® Shaftliner is the right choice when designing for fire resistance and changing air pressure. Shaftwalls are non-load bearing partitions made up of gypsum board and metal framing. These systems are lightweight and economical compared with conventional shaftwalls.

eXP® Area Separation Wall Systems: These systems are a popular method for constructing today's multifamily housing units. These assemblies will be exposed to outdoor elements during the building process, and eXP Shaftliner features a coated glass mat facer and gypsum core that can provide increased protection.

Sizes: 1" (25.4 mm) thick panels are available in 2' (610 mm) nominal widths and standard lengths up to 12' (3,658 mm).

ADVANTAGES

PROVIDES FIRE RESISTANCE

- Fire-resistant material with a non-combustible gypsum core helps protect framing elements, even when cladding is combustible.
- Approved component in specific UL fire-rated designs.

RESISTS MOISTURE AND MOLD

- Provides superior water resistance without impeding vapor transmission.
- Resists the growth of mold per ASTM D3273 with a score of 10, the best possible score.

INSTALLS FAST AND EASY

- Scores and snaps easily without sawing.
- Coated glass mat facers for easy handling.

OFFERS SUPERIOR DURABILITY

- 12-month extended exposure warranty for typical weather conditions.
- Dimensionally stable under changes in temperature and relative humidity.

For details about fire resistance, see installation recommendations on page 33.

eXP[®] Shaftliner

TECHNICAL DATA

Physical Properties	eXP Shaftliner
Thickness ¹ , Nominal	1" (25.4 mm)
Width ¹ , Nominal	2' (610 mm)
Length ^{1,4} , Standard	8' – 12' (2,438 mm – 3,658 mm)
Weight, Nominal	3.75 lbs./sq. ft. (18.31 k/m ²)
Edges ¹	Double Beveled
Flexural Strength ¹ , Perpendicular	≥ 230 lbf. (1,023 N)
Flexural Strength ¹ , Parallel	≥ 80 lbf. (356 N)
Humidified Deflection ¹	N/A
Nail Pull Resistance ¹	≥ 80 lbf. (356 N)
Hardness ¹ – Core, Edges and Ends	≥ 15 lbf. (67 N)
Thermal Resistance ⁵	R = .65
Water Absorption ¹ (% of Weight)	≤ 5%
Linear Expansion with Change Moisture	6.25 x 10 ⁻⁶ "/in./%RH
Coefficient of Thermal Expansion	9.26 x 10 ⁻⁶ "/in./°F
Mold Resistance ⁶ , ASTM D3273	Score of 10
Product Standard Compliance	ASTM C1658

Fire-Resistance Characteristics

Core Type	Type X
UL Type Designation	FSW-7
Combustibility ²	Non-combustible core
Surface Burning Characteristics ³	Class A
Flame Spread ³	0
Smoke Development ³	0

Applicable Standards and References

ASTM C473 *Standard Test Methods for Physical Testing of Gypsum Panel Products*

ASTM C518 *Standard Test Method for Steady-State Thermal Transmission Properties by Means of the Heat Flow Meter Apparatus*

ASTM C840 *Standard Specification for Application and Finishing of Gypsum Board*

ASTM C1658 *Standard Test Method for Resistance to Growth of Mold on the Surface of Interior Coatings in an Environmental Chamber*

ASTM D3273 *Standard Test Method for Resistance to Growth of Mold on the Surface of Interior Coatings in an Environmental Chamber*

ASTM E84 *Standard Test Method for Surface Burning Characteristics of Building Materials*

ASTM E96 *Standard Test Methods for Water Vapor Transmission of Materials*

ASTM E119 *Standard Test Methods for Fire Tests of Building Construction and Materials*

ASTM E136 *Standard Test Method for Behavior of Materials in a Vertical Tube Furnace at 750°C*

Gypsum Association, GA-216, *Application and Finishing of Gypsum Panel Products*

Gypsum Association, GA-238, *Guidelines for Prevention of Mold Growth on Gypsum Board*

Gold Bond Building Products, LLC Manufacturer Standards, *NGC Construction Guide*

1. Specified minimum values per ASTM C1658, tested in accordance with ASTM C473.
2. Tested in accordance with ASTM E136.
3. Tested in accordance with ASTM E84.
4. Please contact your local sales representative for all non-standard lengths and widths. Minimum order requirements may apply.

5. Tested in accordance with ASTM C518.
6. Tested in accordance with ASTM D3273 and rated in accordance with ASTM D3274.

Common eXP® Shaftliner Installation Applications

AREA SEPARATION WALL LIMITING HEIGHTS

- | | |
|---|---------------------------------|
| 1. Roof | 9. ASW Clip |
| 2. Stringer | 10. Wood Stud |
| 3. Top Plate | 11. Horizontal Blocking |
| 4. eXP® Shaftliner | 12. Floor |
| 5. H-Stud | 13. Ceiling |
| 6. Double C-Track (Back-to-Back) | 14. Minimum 3/4" Air Space |
| 7. eXP® Sheathing | 15. Concrete Slab or Foundation |
| 8. Fire Blocking 1" eXP® Shaftliner or Mineral Wool | |

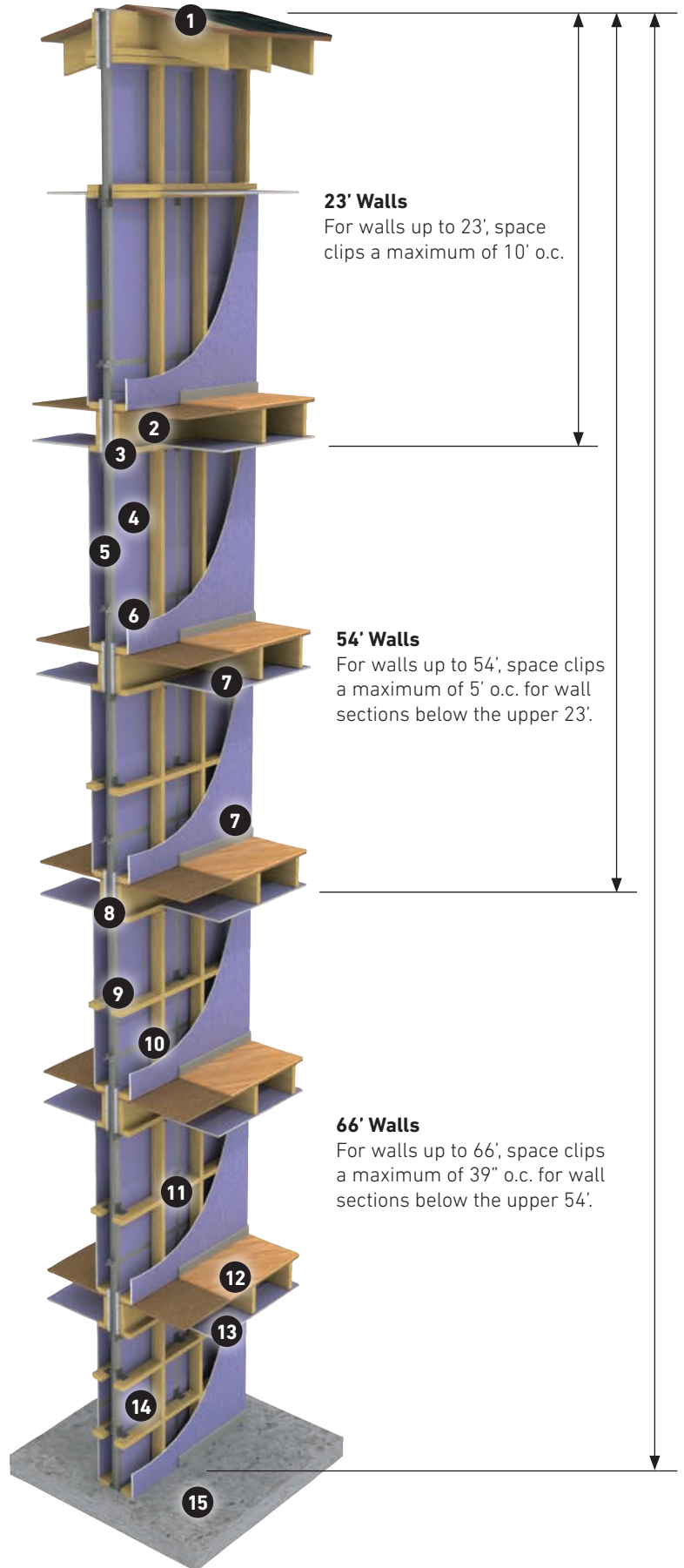
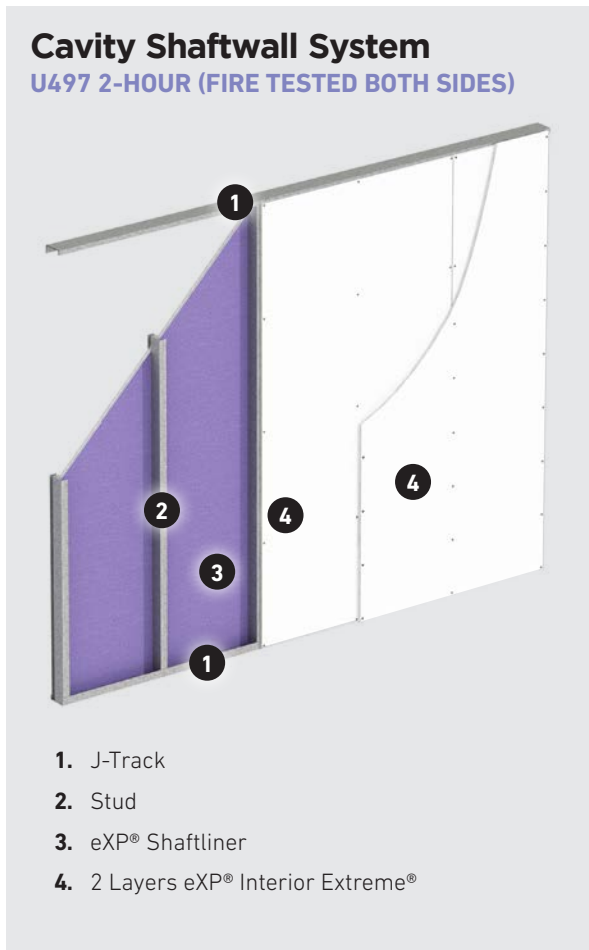
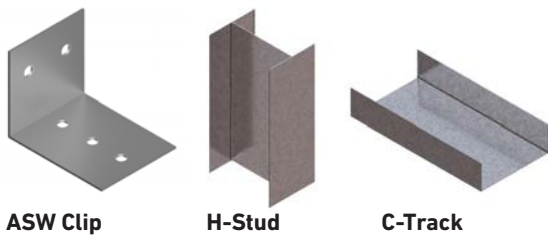

eXP[®] Tile Backer

Tile Substrate for Wet Areas

09 29 00/NGC

Helping to Defend Against Moisture

When you are designing a commercial project that includes high humidity areas, like indoor swimming pools, gang showers, spas and whirlpools, we have the ideal substrate to specify: Gold Bond[®] eXP[®] Tile Backer.

eXP Tile Backer is an acrylic-coated, moisture- and mold-resistant gypsum panel specially designed for use as a substrate for tile applications in high moisture rooms, including showers, bathrooms, indoor swimming pools, laundry rooms and kitchens. Use eXP Tile Backer as a code-compliant substrate for tile and other finishes in both wet and non-wet areas, areas of high humidity and fire-rated assemblies. It is ideally suited for interior walls and ceilings.

eXP Tile Backer is manufactured with an enhanced moisture- and mold-resistant core encased in specially designed coated glass mat facers. The facer is then coated with a specially formulated acrylic coating, which provides superior protection against moisture and humidity. It provides an integral water barrier, eliminating the need for a separate water barrier.

Another reason to consider eXP Tile Backer for your project: It has achieved UL GREENGUARD Gold Certification. UL GREENGUARD Certified products are certified to UL GREENGUARD standards for low chemical emissions into indoor air during product usage. For more information, visit: ul.com/gg.

So the next time you need a product that will perform well in wet, non-wet or high moisture areas that are more susceptible to encouraging mold, think eXP Tile Backer. This substrate will give you the added assurance you need to get the job done to your exacting standards.





1. Acrylic-Coated Water Barrier
2. Coated Fiberglass Mat
3. Enhanced Moisture- and Mold-Resistant Gypsum Core

APPLICATIONS

Gold Bond® eXP® Tile Backer is manufactured with an enhanced moisture- and mold-resistant core encased in specially designed coated glass mat facers. The facer is then coated with a specially formulated acrylic coating, which provides superior protection against moisture and humidity. The glass mat is folded around the long edges to reinforce and protect the core.

- Use it as a substrate for tile applications in high moisture areas, including showers, bathrooms, indoor swimming pools, laundry rooms and kitchens.
- It is also a code-compliant substrate for tile and other finishes in both wet and non-wet areas, areas of high humidity and fire-rated assemblies. It is ideally suited for a variety of interior applications.

Sizes: Regular panels are 1/2" (12.7 mm) thick, available in 4' (1,219 mm) nominal widths, and in 8' (2,438 mm) lengths; Fire-Shield Type X panels are 5/8" (15.9 mm) thick and available in standard lengths.

ADVANTAGES

PROVIDES FIRE RESISTANCE

- Fire-resistant material with a non-combustible gypsum core helps protect framing elements, even when cladding is combustible.
- 5/8" (15.9 mm) eXP® Tile Backer is an approved component in specific UL fire-rated designs.

RESISTS MOISTURE AND MOLD

- Acrylic-coated fiberglass front facer provides an integral water barrier, eliminating the need for a separate water barrier.
- Resists the growth of mold per ASTM D3273 with a score of 10, the best possible score.

INSTALLS FAST AND EASY

- Coated glass mat facers for easy handling.
- Integrated water barrier.

OFFERS SUPERIOR DURABILITY

- Dimensionally stable under changes in temperature and relative humidity.

For details about fire resistance, see installation recommendations on page 33.

eXP[®] Tile Backer

TECHNICAL DATA

Physical Properties	1/2" eXP Tile Backer	5/8" eXP Fire-Shield Tile Backer
Thickness¹, Nominal	1/2" (12.7 mm)	5/8" (15.9 mm)
Width¹, Nominal	4' (1,219 mm)	4' (1,219 mm)
Length^{1,4}, Standard	8' (2,438 mm)	8' (2,438 mm)
Weight, Nominal	2.0 lbs./sq. ft. (9.76 k/m ²)	2.5 lbs./sq. ft. (12.21 k/m ²)
Edges¹	Square	Square
Flexural Strength¹, Perpendicular	≥ 100 lbf. (445 N)	≥ 140 lbf. (623 N)
Flexural Strength¹, Parallel	≥ 80 lbf. (356 N)	≥ 100 lbf. (445 N)
Humidified Deflection¹	≤ 2/8" (6.4 mm)	≤ 1/8" (3.2 mm)
Nail Pull Resistance¹	≥ 70 lbf. (311 N)	≥ 90 lbf. (400 N)
Hardness¹ – Core, Edges and Ends	≥ 15 lbf. (67 N)	≥ 15 lbf. (67 N)
Bending Radius	12' (3,658 mm)	16' (4,877 mm)
Thermal Resistance⁵	R = .43	R = .50
Permeance⁶	2 perms	2 perms
Water Absorption¹ (% of Weight)	≤ 5%	≤ 5%
Surface Water Absorption¹	≤ .5 grams	≤ .5 grams
Linear Expansion with Change Moisture	6.25 x 10 ⁻⁶ "/in./%RH	6.25 x 10 ⁻⁶ "/in./%RH
Coefficient of Thermal Expansion	9.26 x 10 ⁻⁶ "/in./°F	9.26 x 10 ⁻⁶ "/in./°F
Mold Resistance⁷, ASTM D3273	Score of 10	Score of 10
Mold Resistance⁸, ASTM D6329	Pass	Pass
Product Standard Compliance	ASTM C1178	ASTM C1178
Fire-Resistance Characteristics		
Core Type	Regular	Type X
UL Type Designation	N/A	FSW-6
Combustibility²	Non-combustible core	Non-combustible core
Surface Burning Characteristics³	Class A	Class A
Flame Spread³	0	0
Smoke Development³	0	0
Applicable Standards and References		
ASTM C473 <i>Standard Test Methods for Physical Testing of Gypsum Panel Products</i>		
ASTM C518 <i>Standard Test Method for Steady-State Thermal Transmission Properties by Means of the Heat Flow Meter Apparatus</i>		
ASTM C840 <i>Standard Specification for Application and Finishing of Gypsum Board</i>		
ASTM C1178 <i>Standard Specification for Coated Glass Mat Water-Resistant Gypsum Backing Panel</i>		
ASTM D3273 <i>Standard Test Method for Resistance to Growth of Mold on the Surface of Interior Coatings in an Environmental Chamber</i>		
ASTM D6329 <i>Standard Guide for Developing Methodology for Evaluating the Ability of Indoor Materials to Support Microbial Growth Using Static Environmental Chambers</i>		
ASTM E84 <i>Standard Test Method for Surface Burning Characteristics of Building Materials</i>		
ASTM E96 <i>Standard Test Methods for Water Vapor Transmission of Materials</i>		
ASTM E119 <i>Standard Test Methods for Fire Tests of Building Construction and Materials</i>		
ASTM E136 <i>Standard Test Method for Behavior of Materials in a Vertical Tube Furnace at 750°C</i>		
Gypsum Association, GA-214, <i>Levels of Finish for Gypsum Panel Products</i>		
Gypsum Association, GA-216, <i>Application and Finishing of Gypsum Panel Products</i>		
Gypsum Association, GA-238, <i>Guidelines for Prevention of Mold Growth on Gypsum Board</i>		
Gold Bond Building Products, LLC Manufacturer Standards, <i>NGC Construction Guide</i>		

1. Specified values per ASTM C1658, tested in accordance with ASTM C473.

2. Tested in accordance with ASTM E136.

3. Tested in accordance with ASTM E84.

4. Contact your local sales representative for all non-standard lengths and widths. Minimum order requirements may apply.

5. Tested in accordance with ASTM C518.

6. Tested in accordance with ASTM E96.

7. Tested in accordance with ASTM D3273 and rated in accordance with ASTM D3274.

8. Tested in accordance with ASTM D6329.

Common eXP® Tile Backer Installation Applications

SHOWER INSTALLATION

1. eXP® Tile Backer
2. Fiberglass Mesh Tape (Alkali-Resistant) Embedded in Joint Compound
3. Latex Portland Cement Mortar
4. Tile and Grout



SHOWER INSTALLATION

1. Support Framing
1/4" / 12" Slope Towards Drain
2. Plywood, Min. 1/2"
3. eXP® Tile Backer
4. Membrane
5. Sealant
6. Latex Portland Cement Mortar
7. Tile and Grout



Increased Resistance to Incidental Moisture

When Long-Term Exposure to Mold is a Concern

Your project warrants added protection against mold and moisture in interior applications, and Gold Bond[®] eXP[®] Interior Extreme[®] Gypsum Panel is an excellent choice. When designing a building with a non-paper faced gypsum application, this gypsum panel features coated fiberglass facers as well as an enhanced moisture- and mold-resistant gypsum core. The inorganic glass mat is embedded in the core, giving it added strength and moisture-resistant properties.

With eXP Interior Extreme, you can use a single gypsum panel throughout the entire project, wherever gypsum board is specified. This helps to make your job seamless and offers you added peace of mind.

Consider specifying eXP Interior Extreme for pre-rock applications, or before the building envelope is completely enclosed. Use it on the interior side of exterior walls, where moisture exposure is more likely to occur. It is also ideally suited for topping out, helping push the construction schedule to an on-time completion. This flexible substrate works well for both wood- and metal-framed construction.

Easy to work with and handle, eXP Interior Extreme is also approved for specific UL fire-rated designs and it has also achieved UL GREENGUARD Gold Certification. UL GREENGUARD Certified products are certified to UL GREENGUARD standards for low chemical emissions into indoor air during product usage. For more information, visit: ul.com/gg.





1. Coated Fiberglass Mat
2. Tapered Edges
3. Enhanced Moisture- and Mold-Resistant Gypsum Core

APPLICATIONS

Gold Bond® eXP® Interior Extreme® Gypsum Panels consist of a moisture- and mold-resistant gypsum core encased in a coated, specially designed fiberglass mat on the face, back and sides. It is available in a Regular, Type X or Type C core (often specified where the weight and number of gypsum board layers are a concern). The glass mat is folded around the long edges to reinforce and protect the core.

- Use it wherever gypsum board is specified in interior applications for the entire project, wood or metal framing, for increased resistance to incidental moisture.

Sizes: 1/2" (12.7 mm) Regular, 1/2" (12.7 mm) Type C and 5/8" (15.9 mm) Fire-Shield Type X or Type C panels are available in 4' (1,219 mm) nominal widths and in 8' (2,438 mm) to 12' (3,658 mm) lengths.

Finishing: Perform finishing of eXP panels in accordance with GA-214. Joints between eXP panels may be finished with either paper tape and ready mix joint compound or setting compound. In most areas to receive final decoration, skim coating of the entire surface is recommended.

ADVANTAGES

PROVIDES FIRE RESISTANCE

- Fire-resistant material with a non-combustible gypsum core helps protect framing elements, even when cladding is combustible.
- 1/2" (12.7 mm) Fire-Shield C, 5/8" (15.9 mm) Fire-Shield Type X or Type C have specially formulated cores that are approved components in specific UL fire-rated designs.

RESISTS MOISTURE AND MOLD

- Resists the growth of mold per ASTM D3273 with a score of 10, the best possible score.

INSTALLS FAST AND EASY

- Features GridMarX® guide marks on the panel to allow for faster and more accurate installation.
- May use for pre-rock applications before building is completely enclosed, which may speed installation.
- Versatile product can be used throughout the entire project where gypsum board is specified.

OFFERS SUPERIOR DURABILITY

- 12-month extended exposure warranty for typical weather conditions.
- Dimensionally stable under changes in temperature and relative humidity.

For details about fire resistance, see installation recommendations on page 33.

eXP[®] Interior Extreme[®]

TECHNICAL DATA

Physical Properties	1/2" eXP Interior Extreme	1/2" eXP Interior Extreme Fire-Shield C	5/8" eXP Interior Extreme Fire-Shield	5/8" eXP Interior Extreme Fire-Shield C
Thickness¹, Nominal	1/2" (12.7 mm)	1/2" (12.7 mm)	5/8" (15.9 mm)	5/8" (15.9 mm)
Width¹, Nominal	4' (1,219 mm)	4' (1,219 mm)	4' (1,219 mm)	4' (1,219 mm)
Length^{1,4}, Standard	8' – 12' (2,438 mm – 3,658 mm)	8' – 12' (2,438 mm – 3,658 mm)	8' – 12' (2,438 mm – 3,658 mm)	8' – 12' (2,438 mm – 3,658 mm)
Weight, Nominal	2.0 lbs./sq. ft. (9.76 k/m ²)	2.1 lbs./sq. ft. (10.25 k/m ²)	2.5 lbs./sq. ft. (12.21 k/m ²)	2.5 lbs./sq. ft. (12.21 k/m ²)
Edges¹	Tapered	Tapered	Tapered	Tapered
Flexural Strength¹, Perpendicular	≥ 100 lbf. (445 N)	≥ 100 lbf. (445 N)	≥ 140 lbf. (623 N)	≥ 140 lbf. (623 N)
Flexural Strength¹, Parallel	≥ 80 lbf. (356 N)	≥ 80 lbf. (356 N)	≥ 100 lbf. (445 N)	≥ 100 lbf. (445 N)
Humidified Deflection¹	≤ 2/8" (6.4 mm)	≤ 2/8" (6.4 mm)	≤ 1/8" (3.2 mm)	≤ 1/8" (3.2 mm)
Nail Pull Resistance¹	≥ 80 lbf. (356 N)	≥ 80 lbf. (356 N)	≥ 90 lbf. (400 N)	≥ 90 lbf. (400 N)
Hardness¹ – Core, Edges and Ends	≥ 15 lbf. (67 N)	≥ 15 lbf. (67 N)	≥ 15 lbf. (67 N)	≥ 15 lbf. (67 N)
Bending Radius	6' (1,829 mm)	6' (1,829 mm)	8' (2,438 mm)	8' (2,438 mm)
Thermal Resistance⁵	R = .43	R = .43	R = .50	R = .50
Permeance⁶	22 perms	22 perms	19 perms	19 perms
Water Absorption¹ (% of Weight)	≤ 5%	≤ 5%	≤ 5%	≤ 5%
Surface Water Absorption¹	≤ 1.6 grams	≤ 1.6 grams	≤ 1.6 grams	≤ 1.6 grams
Linear Expansion with Change Moisture	6.25 x 10 ⁻⁶ /in./%RH	6.25 x 10 ⁻⁶ /in./%RH	6.25 x 10 ⁻⁶ /in./%RH	6.25 x 10 ⁻⁶ /in./%RH
Coefficient of Thermal Expansion	9.26 x 10 ⁻⁶ /in./°F	9.26 x 10 ⁻⁶ /in./°F	9.26 x 10 ⁻⁶ /in./°F	9.26 x 10 ⁻⁶ /in./°F
Mold Resistance⁷, ASTM D3273	Score of 10	Score of 10	Score of 10	Score of 10
Mold Resistance⁸, ASTM D6329	Pass	Pass	Pass	Pass
Product Standard Compliance	ASTM C1658	ASTM C1658	ASTM C1658	ASTM C1658
Fire-Resistance Characteristics				
Core Type	Regular	Type C	Type X	Type C
UL Type Designation	N/A	eXP-C	FSW-6	eXP-C
Combustibility²	Non-combustible core	Non-combustible core	Non-combustible core	Non-combustible core
Surface Burning Characteristics³	Class A	Class A	Class A	Class A
Flame Spread³	0	0	0	0
Smoke Development³	0	0	0	0
Applicable Standards and References				
ASTM C473 <i>Standard Test Methods for Physical Testing of Gypsum Panel Products</i>				
ASTM C518 <i>Standard Test Method for Steady-State Thermal Transmission Properties by Means of the Heat Flow Meter Apparatus</i>				
ASTM C840 <i>Standard Specification for Application and Finishing of Gypsum Board</i>				
ASTM C1658 <i>Standard Specification for Glass Mat Gypsum Panels</i>				
ASTM D3273 <i>Standard Test Method for Resistance to Growth of Mold on the Surface of Interior Coatings in an Environmental Chamber</i>				
ASTM D6329 <i>Standard Guide for Developing Methodology for Evaluating the Ability of Indoor Materials to Support Microbial Growth Using Static Environmental Chambers</i>				
ASTM E84 <i>Standard Test Method for Surface Burning Characteristics of Building Materials</i>				
ASTM E96 <i>Standard Test Methods for Water Vapor Transmission of Materials</i>				
ASTM E119 <i>Standard Test Methods for Fire Tests of Building Construction and Materials</i>				
ASTM E136 <i>Standard Test Method for Behavior of Materials in a Vertical Tube Furnace at 750°C</i>				
Gypsum Association, GA-214, <i>Levels of Finish for Gypsum Panel Products</i>				
Gypsum Association, GA-216, <i>Application and Finishing of Gypsum Panel Products</i>				
Gypsum Association, GA-238, <i>Guidelines for Prevention of Mold Growth on Gypsum Board</i>				
Gypsum Association, GA-253, <i>Application of Gypsum Sheathing</i>				
Gold Bond Building Products, LLC Manufacturer Standards, <i>NGC Construction Guide</i>				

1. Specified values per ASTM C1658, tested in accordance with ASTM C473.

2. Tested in accordance with ASTM E136.

3. Tested in accordance with ASTM E84.

4. Please consult your local sales representative for all non-standard lengths and widths. Minimum order requirements may apply.

5. Tested in accordance with ASTM C518.

6. Tested in accordance with ASTM E96.

7. Tested in accordance with ASTM D3273 and rated in accordance with ASTM D3274.

8. Tested in accordance with ASTM D6329.

Common eXP® Interior Extreme® Installation Applications

PRE-ROCK INSTALLATION

1. Topping out with eXP® Interior Extreme® Gypsum Panel in an Exposed Environment
2. Pre-rock with eXP® Interior Extreme® Gypsum Panel



SOFFIT INSTALLATION

1. eXP® Interior Extreme® Gypsum Panel
2. Mesh Tape Set in Setting Compound
3. Skim Coat Setting Compound
4. eXP® Sheathing



eXP® Interior Extreme® AR

Strong and Durable

09 29 00/NGC

For High-Traffic Areas Where Indentation and Surface Abrasion are Concerns

We have taken the moisture- and mold-resistant qualities of our eXP® Interior Extreme® IE and improved upon it with Gold Bond® eXP® Interior Extreme® AR (Abuse Resistant) Gypsum Panel. In addition to the standard IE performance benefits, this coated fiberglass-faced gypsum panel also offers an extra level of surface durability.

eXP Interior Extreme AR is designed for a non-paper faced gypsum application, utilizing coated glass mat facers. The specially formulated gypsum core combines enhanced protection against moisture and mold with added surface-abrasion resistance. When you think about eXP Interior Extreme AR, think *strong and durable*.

As with eXP Interior Extreme, consider specifying Interior Extreme AR for pre-rock applications before the building envelope is completely enclosed.

Easy to work with and handle, it is also approved for specific UL fire-rated designs and it has also achieved UL GREENGUARD Gold Certification. UL GREENGUARD Certified products are certified to UL GREENGUARD standards for low chemical emissions into indoor air during product usage. For more information, visit: ul.com/gg.

Areas prone to surface abrasion and indentation include:

- Corridors
- Lobby areas
- Entryways
- Warehouses





1. Coated Fiberglass Mat
2. Tapered Edges
3. Enhanced Moisture- and Mold-Resistant Gypsum Core

APPLICATIONS

Gold Bond® eXP® Interior Extreme® AR Gypsum Panels consist of an abuse-, moisture- and mold-resistant gypsum core encased in a coated, specially designed glass mat on the face, back and sides. In addition to moisture and mold resistance, the AR panel has a denser core and an enhanced glass mat for increased resistance to indentation and abrasion. It is available in a Type X core. The glass mat is folded around the long edges to reinforce and protect the core.

- Use it for interior applications in areas prone to surface abrasion and indentation, including corridors, entryways, lobby areas and warehouses.

Sizes: 5/8" (15.9 mm) Type X Panels are available in 4' (1,219 mm) nominal widths and in standard lengths of 8' (2,438 mm) to 12' (3,658 mm).

Finishing: Perform finishing of eXP panels in accordance with GA-214. Joints between eXP panels may be finished with either paper tape and ready mix joint compound or setting compound. In most areas to receive final decoration, skim coating of the entire surface is recommended.

ADVANTAGES

PROVIDES FIRE RESISTANCE

- Fire-resistant material with a non-combustible gypsum core helps protect framing elements, even when cladding is combustible.
- Manufactured to meet ASTM C1658 "Standard Specification for Glass Mat Gypsum Substrate for use as Sheathing".

RESISTS MOISTURE AND MOLD

- Resists the growth of mold per ASTM D3273 with a score of 10, the best possible score.

INSTALLS FAST AND EASY

- Features GridMarX® guide marks on the panel to allow for faster and more accurate installation.
- Coated glass mat facers for easy handling.

OFFERS SUPERIOR DURABILITY

- 12-month extended exposure warranty for typical weather conditions.
- Dimensionally stable under changes in temperature and relative humidity.

PROVIDES ABUSE RESISTANCE

- Provides greater resistance to surface abuse and impact penetration over gypsum board.

For details about fire resistance, see installation recommendations on page 33.

eXP[®] Interior Extreme[®] AR

TECHNICAL DATA

Physical Properties	eXP Interior Extreme AR
Thickness¹, Nominal	5/8" (15.9 mm)
Width¹, Nominal	4' (1,219 mm)
Length^{1,4}, Standard	8' – 12' (2,438 mm – 3,658 mm)
Weight, Nominal	2.8 lbs./sq. ft. (13.67 k/m ²)
Edges¹	Tapered
Flexural Strength¹, Perpendicular	≥ 140 lbf. (623 N)
Flexural Strength¹, Parallel	≥ 100 lbf. (445 N)
Humidified Deflection¹	≤ 1/8" (3.2 mm)
Nail Pull Resistance¹	≥ 90 lbf. (400 N)
Hardness¹ – Core, Edges and Ends	≥ 15 lbf. (67 N)
Bending Radius	8' (2,438 mm)
Thermal Resistance⁵	R = .50
Permeance⁶	19 perms
Water Absorption¹ (% of Weight)	≤ 5%
Surface Water Absorption¹	≤ 1.6 grams
Linear Expansion with Change Moisture	6.25 x 10 ⁻⁶ /in./%RH
Coefficient of Thermal Expansion	9.26 x 10 ⁻⁶ /in./°F
Mold Resistance⁷, ASTM 3273	Score of 10
Mold Resistance⁸, ASTM 6329	Pass
Surface Abrasion⁹	Level 3
Indentation⁹	Level 1
Soft-Body Impact⁹	Level 2
Hard-Body Impact⁹	Level 1
Product Standard Compliance	ASTM C1658
Fire-Resistance Characteristics	
Core Type	Type X
UL Type Designation	FSW-6
Combustibility²	Non-combustible core
Surface Burning Characteristics³	Class A
Flame Spread³	0
Smoke Development³	0
Applicable Standards and References	
ASTM C473 <i>Standard Test Methods for Physical Testing of Gypsum Panel Products</i>	
ASTM C518 <i>Standard Test Method for Steady-State Thermal Transmission Properties by Means of the Heat Flow Meter Apparatus</i>	
ASTM C840 <i>Standard Specification for Application and Finishing of Gypsum Board</i>	
ASTM C1629 <i>Standard Specification for Abuse-Resistant Nondecorated Interior Gypsum Panel Products and Fiber-Reinforced Cement Panels</i>	
ASTM C1658 <i>Standard Specification for Glass Mat Gypsum Panels</i>	
ASTM D3273 <i>Standard Test Method for Resistance to Growth of Mold on the Surface of Interior Coatings in an Environmental Chamber</i>	
ASTM D6329 <i>Standard Guide for Developing Methodology for Evaluating the Ability of Indoor Materials to Support Microbial Growth Using Static Environmental Chambers</i>	
ASTM E84 <i>Standard Test Method for Surface Burning Characteristics of Building Materials</i>	
ASTM E96 <i>Standard Test Methods for Water Vapor Transmission of Materials</i>	
ASTM E119 <i>Standard Test Methods for Fire Tests of Building Construction and Materials</i>	
ASTM E136 <i>Standard Test Method for Behavior of Materials in a Vertical Tube Furnace at 750°C</i>	
Gypsum Association, GA-214, <i>Levels of Finish for Gypsum Panel Products</i>	
Gypsum Association, GA-216, <i>Application and Finishing of Gypsum Panel Products</i>	
Gypsum Association, GA-238, <i>Guidelines for Prevention of Mold Growth on Gypsum Board</i>	
Gypsum Association, GA-253, <i>Application of Gypsum Sheathing</i>	
Gold Bond Building Products, LLC Manufacturer Standards, <i>NGC Construction Guide</i>	

1. Specified values per ASTM C1658, tested in accordance with ASTM C473.

2. Tested in accordance with ASTM E136.

3. Tested in accordance with ASTM E84.

4. Contact your local sales representative for all non-standard lengths and widths.

5. Minimum order requirements may apply.

6. Tested in accordance with ASTM C518.

7. Tested in accordance with ASTM E96.

8. Tested in accordance with ASTM D3273 and rated in accordance with ASTM D3274.

9. Tested in accordance with ASTM D6329.

10. Tested in accordance with ASTM methods in ASTM C1629 – D4977

(Surface Abrasion), D5420 (Indentation), E695 (Soft-Body Impact), Annex A1 (Hard-Body Impact).

Abuse and Impact Test Results (ASTM C1629)

RECOMMENDED CLASSIFICATION LEVELS FOR COMPLIANCE

Test/Classification Level	Gold Bond eXP Interior Extreme AR Gypsum Board
ASTM D4977 – Surface Abrasion	3
ASTM D5420 – Surface Indentation	1
ASTM E695 – Soft-Body Impact	2
Annex A1 – Hard-Body Impact	1*

* Abuse products are not recommended for areas prone to cavity penetration.

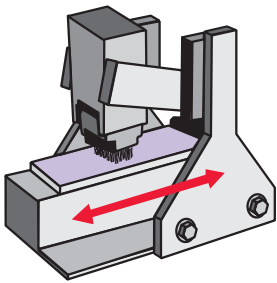

Surface Abrasion

MODIFIED ASTM D4977

This test measures the ability of a gypsum panel surface to resist scratches and scuffs by subjecting the panel to 50 back and forth cycles with a wire brush. The depth of the abrasion is measured. The test was originally developed to test granule adhesion to mineral surfaced roofing and was modified by adding 25 pounds of additional weight to the wire brush.

TEST RESULTS

Classification Level	Abraded Depth Maximum
1	0.126" (3.2 mm)
2	0.059" (1.5 mm)
3	0.010" (0.3 mm)

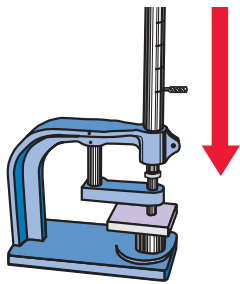

Surface Indentation

ASTM D5420 - GARDNER IMPACT TEST

This test measures the ability of a gypsum panel to resist dents by a small hard object, by raising and dropping a hemispherical rod onto the gypsum panel. The depth of the indentation is measured. The original test was developed to test flat, rigid sheets of plastic.

TEST RESULTS

Classification Level	Indentation Maximum
1	0.150" (3.8 mm)
2	0.100" (2.5 mm)
3	0.050" (1.3 mm)

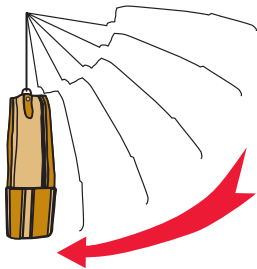

Single Drop Soft-Body Impact

MODIFIED ASTM E695

This test measures the ability of a gypsum panel to withstand a single impact of a heavy soft object. This test is conducted by swinging a leather bag loaded with steel pellets into the panel. When the panel breaks, the height of the drop and weight of the bag are used to calculate the foot-pound measurement required to break the panel. The test was originally developed to measure relative resistance of wall, floor, and roof construction to impact loading.

TEST RESULTS

Classification Level	Soft Body Minimum
1	90'-lbs. (112 J)
2	195'-lbs. (265 J)
3	300'-lbs. (408 J)

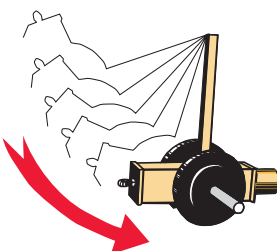

Hard-Body Impact

ANNEX A1

This test measures the ability of a gypsum panel to withstand the impact of a hard object such as a hammer or heel of a boot. A panel is impacted with 2-3/4" steel cylinder mounted to a ram. Weights are added to the ram and the panel is impacted one time. The maximum amount of impact force the panel can withstand without breaching the stud cavity is reported. This is a new test proposed by manufacturers of high performance panels.

TEST RESULTS

Classification Level	Hard Body Minimum
1	50'-lbs. (68 J)
2	100'-lbs. (136 J)
3	150'-lbs. (204 J)

eXP® Interior Extreme® IR

Provides Resistance to Incidental Moisture and Wall Penetration

09 29 00/NGC

For Areas Susceptible to Extreme Abuse and Impact Penetration

eXP® Interior Extreme® IR Gypsum Panels are formulated for ultra-high traffic areas such as corridors in healthcare facilities, schools and correctional institutions, or where abuse may be intentional rather than accidental, making it an even more durable and impact-resistant version of eXP® Interior Extreme® AR Gypsum Panels.

eXP Interior Extreme IR has the same added protection against mold and moisture in interior applications as eXP Interior Extreme. IR is designed for a non-paper faced gypsum application and anywhere impact penetration and heavy traffic is a concern. It utilizes coated fiberglass facers, along with a specially formulated fiberglass mesh embedded into the gypsum core. IR provides a high level of surface-impact resistance. When you think about eXP Interior Extreme IR, think *the toughest board in the series*.

eXP Interior Extreme IR has the features you're already familiar with in our Interior Extreme and Interior Extreme AR products. This flexible substrate works well for both wood- and metal-framed construction. Approved for specific UL fire-rated designs, it has also achieved UL GREENGUARD Gold Certification. UL GREENGUARD Certified products are certified to UL GREENGUARD standards for low chemical emissions into indoor air during product usage. For more information, visit: ul.com/gg.

Areas prone to cavity penetration include:

- Gymnasiums
- Workshop
- Schools
- Correctional facilities





1. Coated Fiberglass Mat
2. Tapered Edges
3. Enhanced Moisture- and Mold-Resistant Gypsum Core
4. Fiberglass Mesh

APPLICATIONS

Gold Bond® eXP® Interior Extreme® IR Gypsum Panels consist of an impact-resistant and a moisture- and mold-resistant gypsum core encased in a coated, specially designed glass mat on the face, back and sides. In addition to moisture and mold resistance, the impact-resistant panel has a denser core and an enhanced glass mat for increased resistance to indentation and impact. Additionally, the fiberglass mesh embedded into the core enhances impact resistance. It is available in a Type X core. The glass mat is folded around the long edges to reinforce and protect the core.

- Use it for interior applications requiring increased resistance to incidental moisture and wall penetrations. It is ideal for areas prone to cavity penetration, including gymnasiums, correctional facilities, schools and workshops.

Sizes: 5/8" (15.9 mm) Type X panels are available in 4' (1,219 mm) nominal widths and standard lengths of 8' (2,438 mm) to 12' (3,658 mm).

Finishing: Perform finishing of eXP panels in accordance with GA-214. Joints between eXP panels may be finished with either paper tape and ready mix joint compound or setting compound. In most areas to receive final decoration, skim coating of the entire surface is recommended.

ADVANTAGES

PROVIDES FIRE RESISTANCE

- Fire-resistant material with a non-combustible gypsum core helps protect framing elements, even when cladding is combustible.
- Approved component in specific UL fire-rated designs.

RESISTS MOISTURE AND MOLD

- Resists the growth of mold per ASTM D3273 with a score of 10, the best possible score.

PROVIDES IMPACT RESISTANCE

- Provides greater resistance to surface abuse and impact penetration over gypsum board.

INSTALLS FAST AND EASY

- Features GridMarX® guide marks on the panel to allow for faster and more accurate installation.
- Coated glass mat facers for easy handling.

OFFERS SUPERIOR DURABILITY

- 12-month extended exposure warranty for typical weather conditions.
- Dimensionally stable under changes in temperature and relative humidity.

For details about fire resistance, see installation recommendations on page 33.

eXP[®] Interior Extreme[®] IR

TECHNICAL DATA

Physical Properties	eXP Interior Extreme IR
Thickness¹, Nominal	5/8" (15.9 mm)
Width¹, Nominal	4' (1,219 mm)
Length^{1, 4}, Standard	8' – 12' (2,438 mm – 3,658 mm)
Weight, Nominal	2.8 lbs./sq. ft. (13.67 k/m ²)
Edges¹	Tapered
Flexural Strength¹, Perpendicular	≥ 140 lbf. (623 N)
Flexural Strength¹, Parallel	≥ 100 lbf. (445 N)
Humidified Deflection¹	≤ 1/8" (3.2 mm)
Nail Pull Resistance¹	≥ 90 lbf. (400 N)
Hardness¹ – Core, Edges and Ends	≥ 15 lbf. (67 N)
Bending Radius	8' (2,438 mm)
Thermal Resistance⁵	R = .50
Permeance⁶	19 perms
Water Absorption¹ (% of Weight)	≤ 5%
Surface Water Absorption¹	≤ 1.6 grams
Linear Expansion with Change Moisture	6.25 x 10 ⁻⁶ /in./%RH
Coefficient of Thermal Expansion	9.26 x 10 ⁻⁶ /in./°F
Mold Resistance⁷, ASTM 3273	Score of 10
Mold Resistance⁸, ASTM 6329	Pass
Surface Abrasion⁹	Level 3
Indentation⁹	Level 1
Soft-Body Impact⁹	Level 3
Hard-Body Impact⁹	Level 2
Product Standard Compliance	ASTM C1658
Fire-Resistance Characteristics	
Core Type	Type X
UL Type Designation	FSW-6
Combustibility²	Non-combustible core
Surface Burning Characteristics³	Class A
Flame Spread³	0
Smoke Development³	0
Applicable Standards and References	
ASTM C473 <i>Standard Test Methods for Physical Testing of Gypsum Panel Products</i>	
ASTM C518 <i>Standard Test Method for Steady-State Thermal Transmission Properties by Means of the Heat Flow Meter Apparatus</i>	
ASTM C840 <i>Standard Specification for Application and Finishing of Gypsum Board</i>	
ASTM C1629 <i>Standard Specification for Abuse-Resistant Nondecorated Interior Gypsum Panel Products and Fiber-Reinforced Cement Panels</i>	
ASTM C1658 <i>Standard Specification for Glass Mat Gypsum Panels</i>	
ASTM D3273 <i>Standard Test Method for Resistance to Growth of Mold on the Surface of Interior Coatings in an Environmental Chamber</i>	
ASTM D6329 <i>Standard Guide for Developing Methodology for Evaluating the Ability of Indoor Materials to Support Microbial Growth Using Static Environmental Chambers</i>	
ASTM E84 <i>Standard Test Method for Surface Burning Characteristics of Building Materials</i>	
ASTM E96 <i>Standard Test Methods for Water Vapor Transmission of Materials</i>	
ASTM E119 <i>Standard Test Methods for Fire Tests of Building Construction and Materials</i>	
ASTM E136 <i>Standard Test Method for Behavior of Materials in a Vertical Tube Furnace at 750°C</i>	
Gypsum Association, GA-214, <i>Levels of Finish for Gypsum Panel Products</i>	
Gypsum Association, GA-216, <i>Application and Finishing of Gypsum Panel Products</i>	
Gypsum Association, GA-238, <i>Guidelines for Prevention of Mold Growth on Gypsum Board</i>	
Gypsum Association, GA-253, <i>Application of Gypsum Sheathing</i>	
Gold Bond Building Products, LLC Manufacturer Standards, <i>NGC Construction Guide</i>	

1. Specified values per ASTM C1658, tested in accordance with ASTM C473.

2. Tested in accordance with ASTM E136.

3. Tested in accordance with ASTM E84.

4. Contact your local sales representative for all non-standard lengths and widths. Minimum order requirements may apply.

5. Tested in accordance with ASTM C518.

6. Tested in accordance with ASTM E96.

7. Tested in accordance with ASTM D3273 and rated in accordance with ASTM D3274.

8. Tested in accordance with ASTM D6329.

9. Tested in accordance with ASTM methods in ASTM C1629 – D4977 (Surface Abrasion), D5420 (Indentation), E695 (Soft-Body Impact), Annex A1 (Hard-Body Impact).

Abuse And Impact Test Results (ASTM C1629)

RECOMMENDED CLASSIFICATION LEVELS FOR COMPLIANCE

Test/Classification Level	Gold Bond eXP Interior Extreme IR Gypsum Board
ASTM D4977 – Surface Abrasion	3
ASTM D5420 – Surface Indentation	1
ASTM E695 – Soft-Body Impact	3
Annex A1 – Hard-Body Impact	2

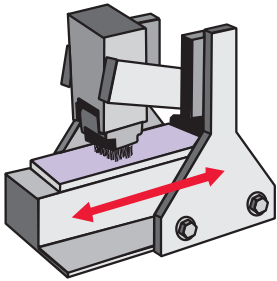

Surface Abrasion

MODIFIED ASTM D4977

This test measures the ability of a gypsum panel surface to resist scratches and scuffs by subjecting the panel to 50 back and forth cycles with a wire brush. The depth of the abrasion is measured. The test was originally developed to test granule adhesion to mineral surfaced roofing and was modified by adding 25 pounds of additional weight to the wire brush.

TEST RESULTS

Classification Level	Abraded Depth Maximum
1	0.126" (3.2 mm)
2	0.059" (1.5 mm)
3	0.010" (0.3 mm)

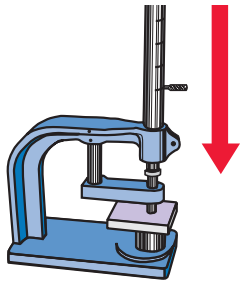

Surface Indentation

ASTM D5420 - GARDNER IMPACT TEST

This test measures the ability of a gypsum panel to resist dents by a small hard object, by raising and dropping a hemispherical rod onto the gypsum panel. The depth of the indentation is measured. The original test was developed to test flat, rigid sheets of plastic.

TEST RESULTS

Classification Level	Indentation Maximum
1	0.150" (3.8 mm)
2	0.100" (2.5 mm)
3	0.050" (1.3 mm)

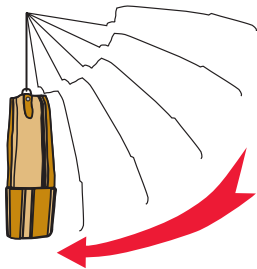

Single Drop Soft-Body Impact

MODIFIED ASTM E695

This test measures the ability of a gypsum panel to withstand a single impact of a heavy soft object. This test is conducted by swinging a leather bag loaded with steel pellets into the panel. When the panel breaks, the height of the drop and weight of the bag are used to calculate the foot-pound measurement required to break the panel. The test was originally developed to measure relative resistance of wall, floor, and roof construction to impact loading.

TEST RESULTS

Classification Level	Soft Body Minimum
1	90'-lbs. (112 J)
2	195'-lbs. (265 J)
3	300'-lbs. (408 J)

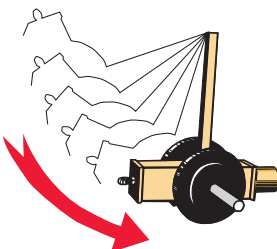

Hard-Body Impact

ANNEX A1

This test measures the ability of a gypsum panel to withstand the impact of a hard object such as a hammer or heel of a boot. A panel is impacted with 2-3/4" steel cylinder mounted to a ram. Weights are added to the ram and the panel is impacted one time. The maximum amount of impact force the panel can withstand without breaching the stud cavity is reported. This is a new test proposed by manufacturers of high performance panels.

TEST RESULTS

Classification Level	Hard Body Minimum
1	50'-lbs. (68 J)
2	100'-lbs. (136 J)
3	150'-lbs. (204 J)

Fire and Sound Selector

GYPSUM BOARD PARTITIONS – SHAFTWALL SYSTEMS

No.	Fire Rating	UL/GA Design	Description	STC	Test No.
1	1 Hr.	W419 U499 WP 6905	1" (25.4 mm) Fire-Shield Shaftliner inserted between flanges of 2-1/2" (63.6 mm) steel C-T, C-H, or I studs 24" (610 mm) o.c. 5/8" (15.9 mm) Fire-Shield Gypsum Board applied vertically or horizontally to studs with 1" (25.4 mm) Type S screws 12" (305 mm) o.c. on side opposite shaftliner panel.	37	NGC 2001003
				42	NGC 2542
2	2 Hr.	W419 U498 WP 7077	1" (25.4 mm) Fire-Shield Shaftliner inserted between flanges of 2-1/2" (63.6 mm) steel C-T, C-H, or I studs 24" (610 mm) o.c. 5/8" (15.9 mm) Fire-Shield Gypsum Board applied vertically or horizontally to each side of studs with 1" (25.4 mm) Type S screws 12" (305 mm) o.c. Joints staggered each side.	42	NGC 2535
				48	NGC 2534
3	2 Hr.	W419 U497 WP 7076	1" (25.4 mm) Fire-Shield Shaftliner inserted between flanges of 2-1/2" (63.6 mm) steel C-T, C-H, or I studs 24" (610 mm) o.c. Base layer 5/8" (15.9 mm) Fire-Shield Gypsum Board applied vertically to studs with 1" (25.4 mm) Type S screws 24" (610 mm) o.c. on side opposite shaftliner panel. Face layer 5/8" (15.9 mm) Fire-Shield Gypsum Board applied vertically with 1-5/8" (41.3 mm) Type S screws 12" (305 mm) o.c. Joints staggered each layer.	41	NGC 2508
				48	NGC 2507
4	1 Hr.	V438 U465 WP 1081	5/8" (15.9 mm) Fire-Shield Gypsum Board applied vertically to each side of 3-5/8" (92.1 mm) steel studs 24" (610 mm) o.c. with 1" (25.4 mm) Type S screws 8" (203 mm) o.c. at vertical joints and 12" (305 mm) o.c. at intermediate studs.	47	NGC 2386
				47	NGC 2386
5	2 Hr.	V438 U411 WP 1548	Base layer 5/8" (15.9 mm) Fire-Shield Gypsum Board applied vertically to each side of 2-1/2" (63.6 mm) steel studs 24" (610 mm) o.c. with 1" (25.4 mm) Type S screws 16" (406 mm) o.c. Face layer 5/8" (15.9 mm) Fire-Shield Gypsum Board applied vertically to each side with 1-5/8" (41.3 mm) Type S screws 16" (406 mm) o.c. at vertical joints and intermediate studs and 12" (305 mm) o.c. at floor and ceiling runners. Joints staggered each layer and side.	56	NGC 3022
				56	NGC 3022

AREA SEPARATION FIRE WALLS

No.	Fire Rating	UL/GA Design	Description	STC	Test No.
6	2 Hr.	U347 ASW 0988	Two layers of 1" (25.4 mm) Fire-Shield Shaftliner inserted between flanges of 2" (50.8 mm) steel H-studs 24" (610 mm) o.c. 3/4" (19.1 mm) air space each side. 2x4 (38.1 mm x 88.9 mm) wood stud partition with one layer of 1/2" (12.7 mm) Gold Bond Gypsum Board on each side.	61	RAL-TL05-199
				61	RAL-TL05-199

Installation Recommendations

GENERAL

- Install gypsum panels in accordance with methods described in ASTM C840 and GA-216. Note that cutting and scoring should be from the back side of the panels.
- Examine and inspect framing materials to which gypsum panels are to be applied. Remedy all defects prior to installation of the gypsum board.
- Apply gypsum panels first to ceilings at right angles to framing members, then to walls. Use boards of maximum practical length so that the minimum number of end joints occur. Bring panel edges into contact with each other but do not force into place.
- Install batt or blanket ceiling insulation BEFORE the gypsum panels on ceilings when installing a vapor retarder behind the gypsum panels. Install the insulation IMMEDIATELY after the gypsum panels when using loose fill insulation. Avoid installation practices that might allow condensation to form behind panels.
- Locate gypsum panel joints at openings so that no joint will occur within 12" (305 mm) of the edges of the opening unless installing control joints at these locations. Stagger vertical end joints. Joints on opposite sides of a partition should not occur on the same stud.
- Hold gypsum panels in firm contact with the framing member while driving fasteners. Fastening should proceed from center portion of the panels toward the edges and ends. Set fasteners with heads slightly below the surface of the panels. Take care to avoid breaking the fiberglass mat of the gypsum panel. Remove improperly driven nails or screws.
- Provide minimum 1/4" (6.4 mm) clearance between boards and adjacent concrete or masonry to minimize wicking of moisture.
- Maintain a room temperature of not less than 40°F (4°C) during application of gypsum panels.

SAFETY

Installers should wear long pants and a long-sleeved, loose-fitting shirt. Use protective gloves and special eye protection (goggles or safety glasses with side shield). Wear a dust mask when sanding; you may need additional breathing protection in extremely dusty conditions. Do not use a power saw to cut this product.

Caution: Because this product contains fiberglass, dust and glass fibers may be released during normal handling, which could result in eye or skin irritation or cause difficulty in breathing. Wherever possible, avoid contact with the skin and eyes and avoid breathing dust or fibers that may be released during installation. Consult the SDS for this product, available at: goldbondbuilding.com before use.

FASTENING

eXP® Sheathing® – Fasteners (nail or screw heads or the crown of staples) should bear tightly against the face of the sheathing panel but should not cut into the facer. Staples should be driven with the crown parallel to the framing. Fasteners should be no less than 3/8" (9.5 mm) from the edges and ends of the panel. When shear values are not required, fasteners should be spaced not more than 8" (203 mm) o.c. along the vertical ends or edges and intermediate supports.



Nails

- Galvanized, 11 gauge
- 7/16" (11.1 mm) head, 1-1/2" (38.1 mm) long for 1/2" (12.7 mm) sheathing
- 1-3/4" (44.5 mm) long for 5/8" (15.9 mm) sheathing



Staples

- Galvanized 16 gauge, 7/16" (11.1 mm) crown, 1-1/2" (38.1 mm) long for 1/2" (12.7 mm) sheathing
- 1-5/8" (41.3 mm) long for 5/8" (15.9 mm) sheathing



Screws

- ASTM C1002 or ASTM C954
- 1-1/4" (31.8 mm) long Type W for wood framing
- 1" (25.4 mm) long Type S-12 for metal framing



FIRE-RESISTANCE RATINGS

Fire-resistance ratings represent the results of tests on assemblies made up of specific materials in a specific configuration. When you are selecting construction designs to meet certain fire-resistance requirements, use caution to ensure that each component of the assembly is specified in the test. Take further precautions to ensure that assembly procedures are in accordance with those of the tested assembly. For additional fire safety information, please refer to goldbondbuilding.com. For copies of specific tests, call 1-800-NATIONAL® Construction Services.



SUSTAINABLE DESIGN

Recycled content data and manufacturing location data are available for Gold Bond products based upon current Gold Bond Building Products, LLC distribution plan and manufacturing location capabilities at the National Gypsum Company Green Product Score website: gps.nationalgypsum.com



UL GREENGUARD CERTIFICATION

Select eXP® products have achieved UL GREENGUARD and UL GREENGUARD Gold Certification. UL GREENGUARD Certified products are certified to UL GREENGUARD standards for low chemical emissions into indoor air during product usage. For details, visit: ul.com/gg.

Installation Recommendations (continued)



eXP® SHEATHING

- eXP® Sheathing may be attached parallel to or perpendicular to wood or metal framing. For horizontal applications, install eXP Sheathing with end joints staggered.
- Use appropriate panel orientation for specific fire assemblies and shear wall applications, as required by the design.
- Install fire-rated assemblies in accordance with the details found in the *UL Fire Resistance Directory* or the Gypsum Association's GA-600, *Fire-Resistance Design Manual*.
- Install eXP Sheathing with vertical edges butting over the center of framing members. Fit sheathing snugly around all openings.
- Install panels with a 3/8" (9.5 mm) gap where non-load-bearing construction abuts structural elements.
- To prevent wicking, install panels with a 1/4" (6.4 mm) gap where they abut masonry or similar materials that might retain moisture.



eXP® SHAFTLINER

- Install eXP® Shaftliner consistent with methods described in specific application details for National Gypsum Cavity Shaftwall Systems or Area Separation Fire Wall Systems in *NGC Construction Guide*, or with other fire-rated designs.



eXP® TILE BACKER

- Do not embed eXP® Tile Backer into mortar bed in showers. Install with gray side facing away from the framing, apply tile/finishes to the gray side.
- Score/cut from the gray side using a standard utility knife. Cut outs are made easily with a utility knife or saw. Panel joints must be tight.
- Fill gaps and inside corners with flexible sealant.
- Drive fasteners flush with the panel surface; do not countersink. Use corrosion resistant buglehead screw for steel and wood framing or a galvanized roofing nail for wood framing.
- Hold tile backer boards in firm contact with the framing member while driving fasteners.
- Fastening should proceed from center portion of the panels toward the edges and ends. Take care to avoid breaking the face of the tile backer board. Remove improperly driven nails or screws.
- Provide minimum 1/4" (6.4 mm) clearance between boards and adjacent concrete or masonry to minimize wicking of moisture.
- Embed alkali-resistant fiberglass tape with the tile setting material at tile backer board joints prior to tile installation.
- Maintain a room temperature of not less than 40°F (4°C) during application of tile backer boards.
- Install fire-rated assemblies in accordance with the details found in the *UL Fire Resistance Directory* or the Gypsum Association, GA-600, *Fire Resistance Design Manual*.



eXP® INTERIOR EXTREME®

- Install fire-rated assemblies in accordance with the details found in the *UL Fire Resistance Directory* or the Gypsum Association, GA-600, *Fire Resistance Design Manual*.
- Drive fasteners just below the surface, avoiding damage to the core and/or glass mat facer.
- It is permissible in pre-rock assemblies to apply level one taping only on vertical applications using setting type joint compound. Do not allow the taped areas to have direct contact with cascading water.



eXP® INTERIOR EXTREME® AR

- Listed impact ratings apply to walls constructed with eXP® Interior Extreme® AR applied with long edges parallel to and centered over minimum 20-gauge framing members spaced a maximum of 16" (406 mm) o.c.
- Install fire-rated assemblies in accordance with the details found in the *UL Fire Resistance Directory* or the Gypsum Association, GA-600, *Fire Resistance Design Manual*.
- Drive fasteners just below the surface, avoiding damage to the core and/or glass mat facer.
- It is permissible in pre-rock assemblies to apply level one taping only on vertical applications using setting type joint compound. Do not allow the taped areas to have direct contact with cascading water.



eXP® INTERIOR EXTREME® IR

- When handling eXP® Interior Extreme® IR, cutting and scoring should be from the back side of the panels.
- Listed impact ratings apply to walls constructed with eXP Interior Extreme IR applied with long edges parallel to and centered over minimum 20-gauge framing members spaced a maximum of 16" (406 mm) o.c.
- Install fire-rated assemblies in accordance with the details found in the *UL Fire Resistance Directory* or the Gypsum Association, GA-600, *Fire Resistance Design Manual*.
- Drive fasteners just below the surface, avoiding damage to the core and/or glass mat facer.
- It is permissible in pre-rock assemblies to apply level one taping only on vertical applications using setting type joint compound. Do not allow the taped areas to have direct contact with cascading water.



National Gypsum Company

National Gypsum Company is the exclusive service provider of reliable, high-performance building products manufactured by its affiliate companies and marketed under the Gold Bond®, ProForm®, and PermaBASE® brands. The strategic network of Gold Bond, ProForm, and PermaBASE manufacturing facilities located throughout major metropolitan hubs in North America allows us to provide the best in customer service so we can keep your fast-paced projects moving forward.

SUSTAINABILITY

Our brands create products that contribute to sustainable design by providing healthy indoor air quality; moisture, mold and mildew management; durability; optimal acoustics; life safety and increased space functionality. No matter how you define sustainability, we offer the most comprehensive set of value-added solutions in the industry.

TRUSTED PARTNER

The National Gypsum name has been synonymous with high-quality, innovative products and exceptional customer service since 1925. Our technical experts at 1-800-NATIONAL® are always a phone call away to answer any type of product or specification question.

We are Building Products for a Better Future® - one project at a time.

LIMITED WARRANTY AND REMEDIES

Products manufactured by Gold Bond Building Products, LLC ("Seller") are warranted by Seller to its customers to be free from defects in materials and workmanship at the time of shipment. Additional or different express limited warranties, limitations and exclusions may apply to specific Seller products.

Current warranty information on such products for both commercial and residential applications is available at goldbondbuilding.com. THIS EXPRESS WARRANTY IS THE ONLY WARRANTY APPLICABLE TO SUCH PRODUCTS, AND IS IN LIEU OF AND EXCLUDES ALL OTHER EXPRESS ORAL OR WRITTEN WARRANTIES AND ALL IMPLIED WARRANTIES, INCLUDING BUT NOT LIMITED TO THE IMPLIED WARRANTIES OF MERCHANTABILITY AND FITNESS FOR A PARTICULAR PURPOSE.

Seller will not be liable for any incidental, indirect or consequential losses, damages or expenses. The customer's exclusive remedy for any type of claim or action for defective products will be limited to the replacement of the products (in the form originally shipped) or, at Seller's option, to a payment or credit not greater than the original purchase price of the products.

Seller will not be liable for products claimed to be defective where the defect resulted from causes not within Seller's control, or which arose or occurred after shipment, including but not limited to accidents, misuse, mishandling, improper installation, contamination or adulteration by other materials or goods, or abnormal conditions of temperature, moisture, dirt or corrosive matter.

Any claim that products sold by Seller were defective or otherwise did not conform to the contract of sale is waived unless the customer submits it in writing to National Gypsum Services Company d/b/a National Gypsum Company, authorized sales agent and service provider to Seller, within thirty (30) days from the date the customer discovered or should have discovered the defect or non-conformance. No legal action or proceeding complaining of goods sold by Seller may be brought by the customer more than one year after the date the customer discovered or should have discovered the defect or problem of which it complains.

MOLD AND MILDEW RESISTANCE

eXP products were designed to provide extra protection against mold and mildew. When tested by an independent laboratory, eXP products received the highest possible ratings on ASTM G 21 and D 3273. The use of eXP products in actual installations may not produce the same results as were achieved in controlled laboratory conditions.

No material can be considered "mold-proof," nor is it certain that any material will resist mold or mildew indefinitely. When used in conjunction with good design, handling and construction practices, eXP products can provide increased mold resistance. As with any building material, avoiding water exposure during handling, storage and installation, and after installation is complete, is the best way to avoid the formation of mold or mildew.

Technical Information

Visit goldbondbuilding.com or call National Gypsum Company Construction Services: 1-800-NATIONAL (628-4662).

Technical Information Información Técnica

1-800-NATIONAL®

1-800-628-4662

National Gypsum Company is the exclusive service provider for products manufactured by Gold Bond Building Products, LLC. The Gold Bond eXP family of products is manufactured by Gold Bond Building Products, LLC.

The color Purple is a registered trademark of Gold Bond Building Products, LLC.

Customer Service

- | | |
|--|---|
| Atlantic Area
(800) 237-9167
atlanticareacsrs@nationalgypsum.com | Northeast Area
(800) 253-3161
northeastareacsrs@nationalgypsum.com |
| Central Area
(800) 252-1065
centralareacsrs@nationalgypsum.com | Southeast Area
(800) 548-9394
southeastareacsrs@nationalgypsum.com |
| Gulf Area
(800) 343-4893
gulfareacsrs@nationalgypsum.com | Southwest Area
(800) 548-9396
southwestareacsrs@nationalgypsum.com |
| Midwest Area
(800) 323-1447
midwestareacsrs@nationalgypsum.com | Western Area
(800) 824-4227
westernareacsrs@nationalgypsum.com |

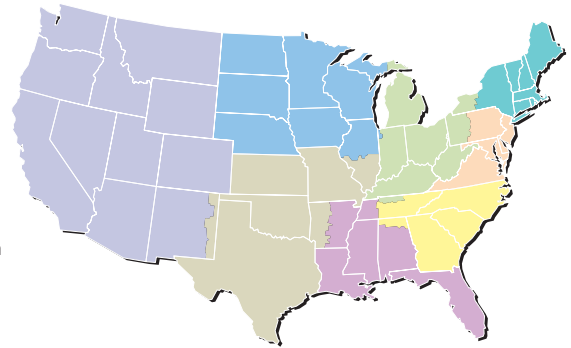

Exclusive service provider of products manufactured by Gold Bond Building Products, LLC.



Gold Bond®
Building Products

Gold Bond Building Products, LLC
2001 Rexford Road
Charlotte, NC 28211

704.365.7300
goldbondbuilding.com