

Area Separation Wall Systems

Fire & sound protection for multifamily construction



CONTACT INFORMATION

PABCO® Gypsum is a division of PABCO® building products, LLC
PO Box 419074
Rancho Cordova, CA 95741
Technical Services: 866-282-9298
www.PABCOgypsum.com

WE'RE ALWAYS HERE TO HELP

PABCO® Gypsum prides itself on the unsurpassed expertise that we offer our customers: architects, engineers, contractors, distributors and owners. Our team of experts are available to answer your questions and assist in the selection of the right product for your project.

PABCO® GYPSUM TECHNICAL SERVICES

We are here for you. At PABCO® Gypsum, technical support is one of the most important services we provide to the building community. Our technical services team is staffed by some of the most experienced professionals in the field. From selecting the right product for the job to proper installation questions, our expertise is always available to you.

PABCO® Technical Support by phone 866-282-9298
By Email techservices@pabco gypsum.com

PABCO GYPSUM SALES TEAMS

PABCO® Gypsum and its QuietRock® product division have a sales organization of inside and outside sales professionals that are focused on your success.

Sales Support by phone 877-449-7786
By Email info@PABCOgypsum.com
On the Web www.PABCOgypsum.com

QuietRock® acoustical products
Sales Support by phone 800-797-8159
By Email info@QuietRock.com
On the Web www.QuietRock.com

Table of Contents

- GENERAL INFORMATION**
 - H-Stud Area Separation Wall System Details 4
 - PABCO® ASW Overview 5
 - PABCO GA -ASFW 0985 Detail 6

- ASSEMBLY COMPONENTS**
 - Primary Assembly Components 7
 - H-Stud & C-Runner Properties 8
 - Additional Assembly Components 9

- TECHNICAL DATA & FEATURES**
 - Technical Data & Features 10
 - Performance Testing 11
 - Design Requirements 12
 - Design Details 13

- INSTALLATION**
 - Foundation & First Floor 14
 - Intermediate Floors & Roof 15

H-Stud Area Separation Wall System

GA -ASFW 0985*, Two Hour

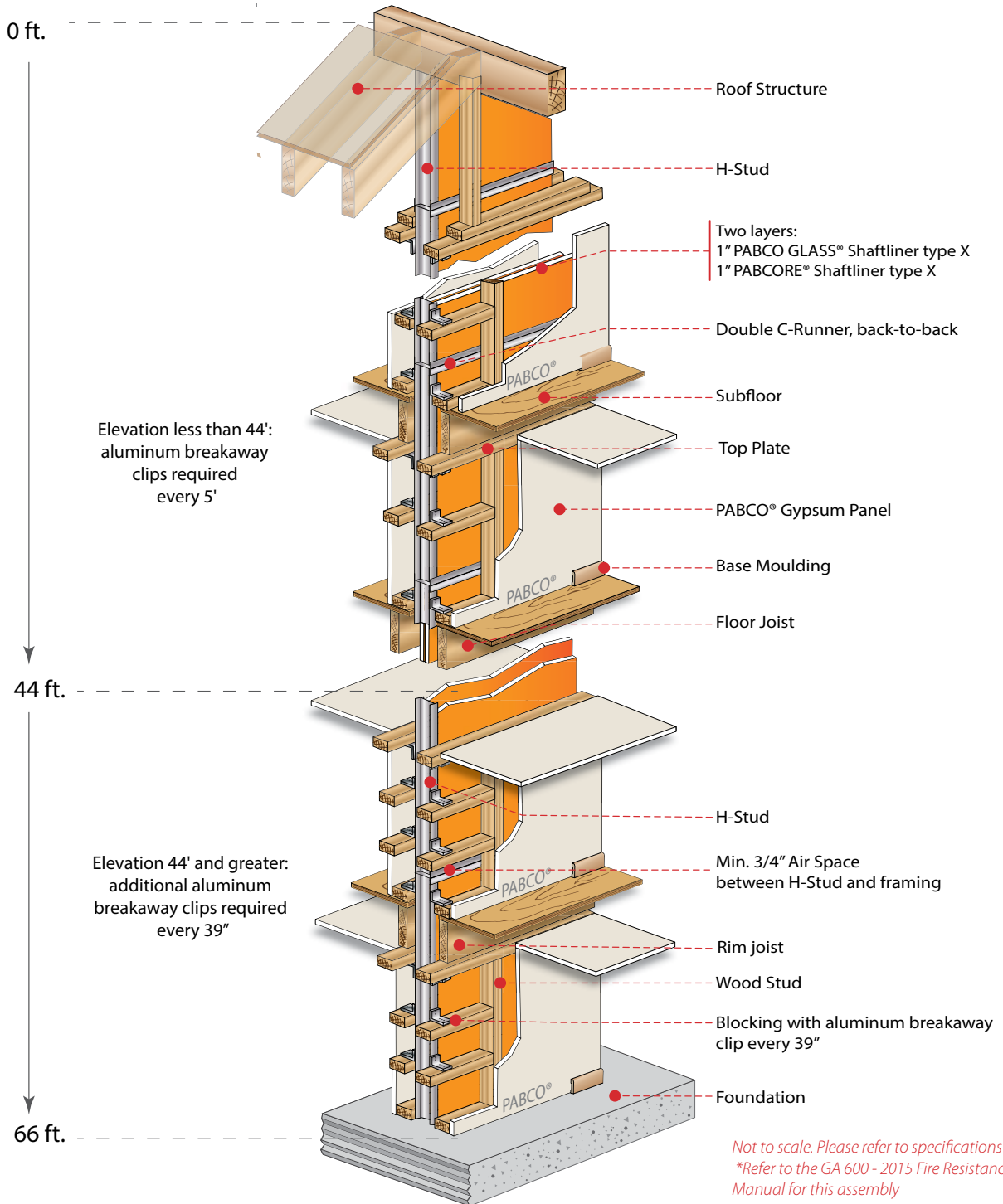

Introduction to The PABCO Area Separation Wall System (ASW)

The unique design of multifamily, multi-storied townhouses and condominiums requires special methods of construction that will provide fire resistance and acoustical separation between dwelling units. The PABCO® H-Stud Area Separation Wall System (ASW) has been developed to meet these critical design criteria.

Weighing no more than ten pounds per square foot when erected, the PABCO® H-Stud ASW provides a code compliant, efficient, lightweight and low cost solution for separating townhouses, condos, and other multifamily dwelling units by eliminating the necessity of costly footers and foundation modifications. An important benefit of the H-Stud ASW is that it may be easily erected directly onto a poured concrete slab by the contractor already on site. Carpenters can easily install the H-Stud ASW modular system progressively once the framing for one residence is completed and prior to the construction of the adjacent unit. The popularity of the non-load bearing gypsum board H-Stud ASW has grown as contractors and architects discover the efficiency, simplicity and cost effectiveness of the system.

The H-Stud ASW is a two-hour fire-resistance rated assembly specifically designed to protect the occupants in attached multi-unit residences. Extending continuously from the foundation to, or through the roof, the H-Stud ASW provides sufficient structural stability under fire conditions to allow collapse of construction on either side without the collapse of the wall. The H-Stud ASW will also provide a sound attenuation of 60-64 STC when required and constructed to PABCO® Gypsum's specifications. The H-Stud ASW can be constructed up to four stories (66 feet) tall, encompassing all common floor-ceiling heights, while providing the highest level of fire and sound performance.

The key component of the H-Stud ASW is a continuous double layer of 1-inch thick, Type X, non-combustible PABCORE® Shaftliner or PABCO GLASS® Shaftliner panels installed in a continuous assembly from the foundation to the roof, and from the front to the back wall. This construction restricts the spread of fire while maintaining sufficient structural stability under fire conditions to allow collapse of construction on either side without the collapse of the ASW or compromising structural integrity. Structural support is provided by steel C-Runners and H-Studs. Horizontal structural support is provided by L-Shaped "breakaway" aluminum slips, as described in the following section. Depending upon the application, the ASW may be extended beyond the roof to form a parapet, or may terminate at the roof level.

Shaftliner panels and metal components are easily stacked to allow progressive construction of the ASW during the framing stages of the building.

Breakaway aluminum clips allow for the collapse of the structure on the fire-exposed side without collapse of the entire wall or compromising its structural integrity. The ASW assembly is attached to each unit's structural framework using L-Shaped aluminum "breakaway" clips fastened to each side of the ASW's steel H-Studs and to the structure of each unit. The L-Shaped aluminum clips connect each H-Stud on both sides at specified intervals based upon wall height to keep the area separation in place between the two structures. The L-Shaped aluminum clips are designed to soften and yield to the heat of the fire at approximately 1,100°F. When one side is exposed to fire, the clips on the exposed fire side soften and breakaway allowing the structure on the exposed fire side to collapse. Because temperatures on the unexposed side of the ASW will be far below the point at which the clip will soften, the aluminum clips will remain intact allowing the ASW to remain intact and in place, thus protecting the adjacent townhouse.



PABCO® GA -ASFW 0985

H-Stud Area Separation Wall System

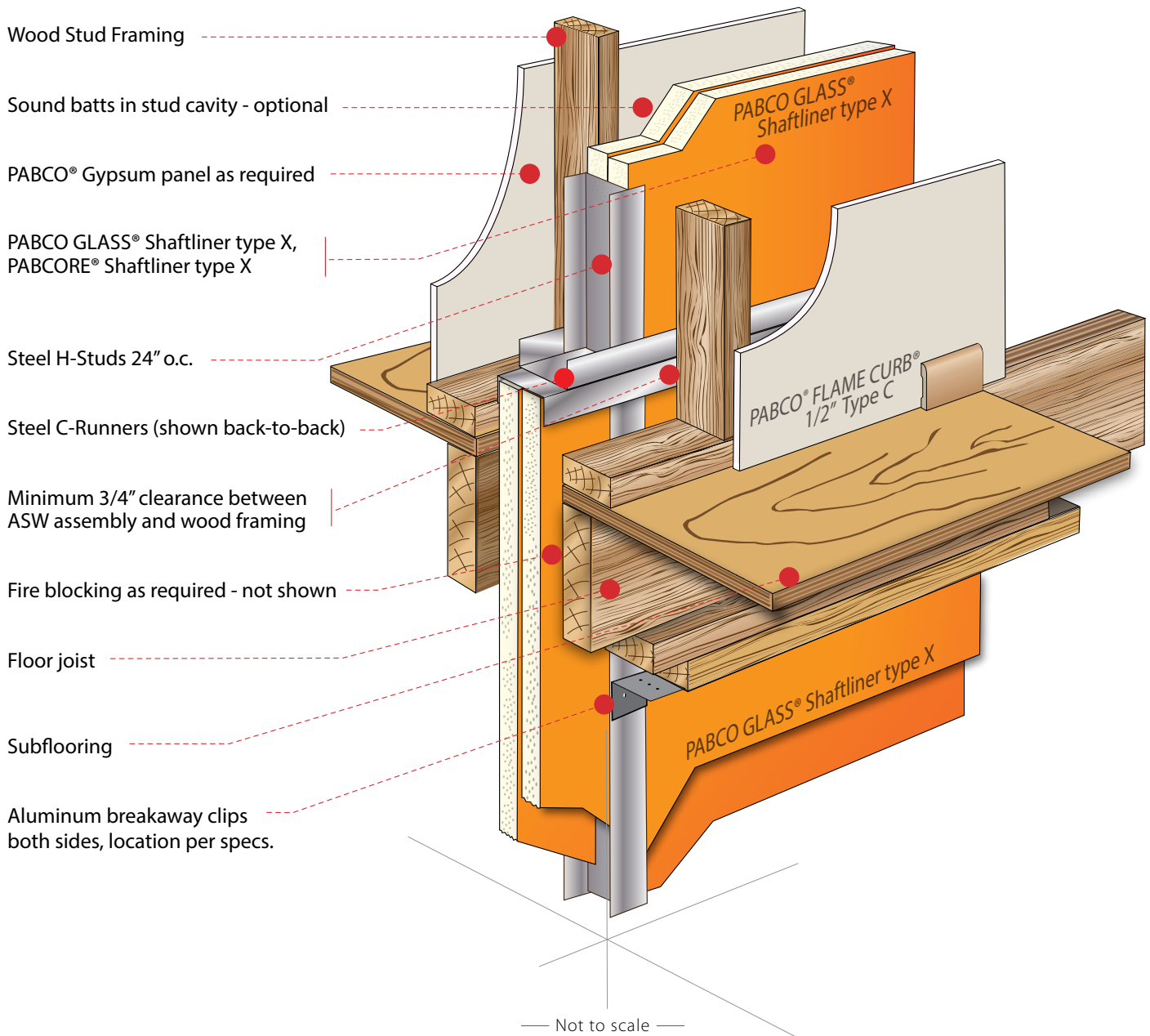

Primary Assembly Components

PABCO® Gypsum Panels:

The following products are suitable in this system:

Central Wall:

- 1" PABCO GLASS® Shaftliner Type X
- 1" PABCORE® Shaftliner Type X

Flanking wall:

- Any PABCO® or QuietRock® gypsum panel

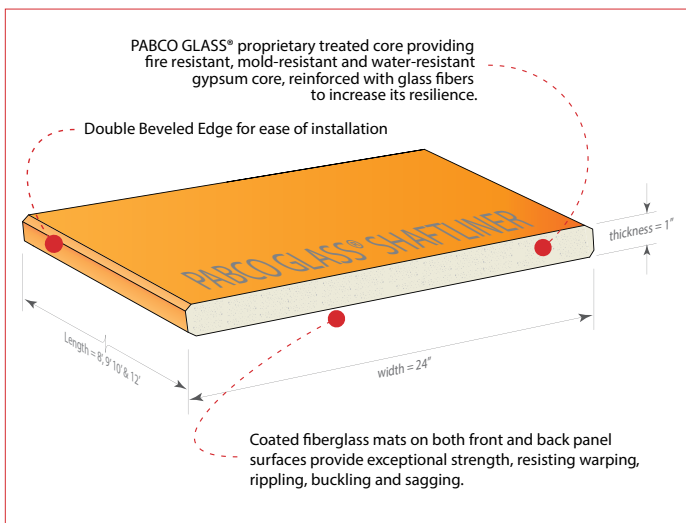

Steel H-Studs:

H-studs are the key framing component, adding structural integrity to Area Separation Wall (ASW) assemblies. The H-studs secure two layers of 1" thick shaftliner panels between adjacent studs. The 2" -deep H-Studs are inserted into the horizontal C-Runners.

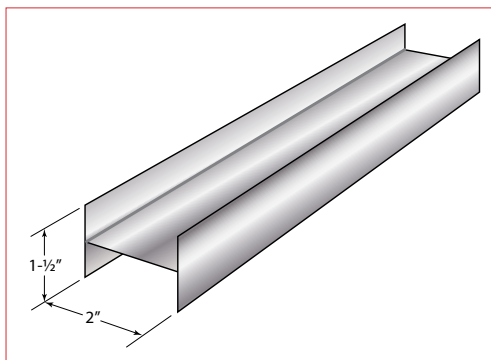

Steel C-Runners

A C-runner is used at the top and bottom of vertical panels to secure 1" thick PABCO® Shaftliner panels and H-studs in ASW assemblies.

C-Runner is used back-to-back at intermediate floors to provide a joining system so the ASW assembly can be erected one floor at a time.

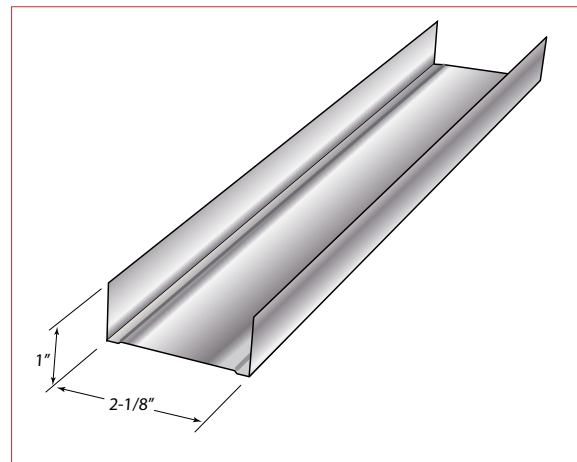

Aluminum Breakaway Clips:

Aluminum Breakaway Clips are used as an integral part of the ASW assembly as a fuse attachment to the main wall assembly. This clip is designed to melt or yield to the high temperatures on the fire side of the wall allowing the fire engaged wall assembly to collapse while detaching itself from the area separation wall. Breakaway clips on the non-fire side remain intact while holding the ASW in place as a barrier to contain the fire within the unit of origin.

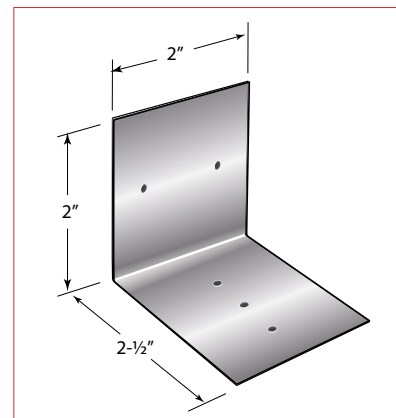

Primary Assembly Components

H-Stud & C-Runner Properties

H-STUD & C-RUNNER PROPERTIES:

| Component | Thickness | | Size | | Weight |
|-----------|----------------|--------------------|-------------------|--|-----------------------------|
| | Gauge | Design Thickness | Width | Length | |
| H-Stud | 25 ga (18 mil) | 0.0188" (0.478 mm) | 2-1/16" (52.4 mm) | 8' (2438 mm) 10' (3048 mm) 12' (3658 mm) | 0.44 lbs/ft (0.656 kg/m) |
| C-Runner | | | 2-1/8" (54 mm) | 8' (2438 mm) 10' (3048 mm) | |

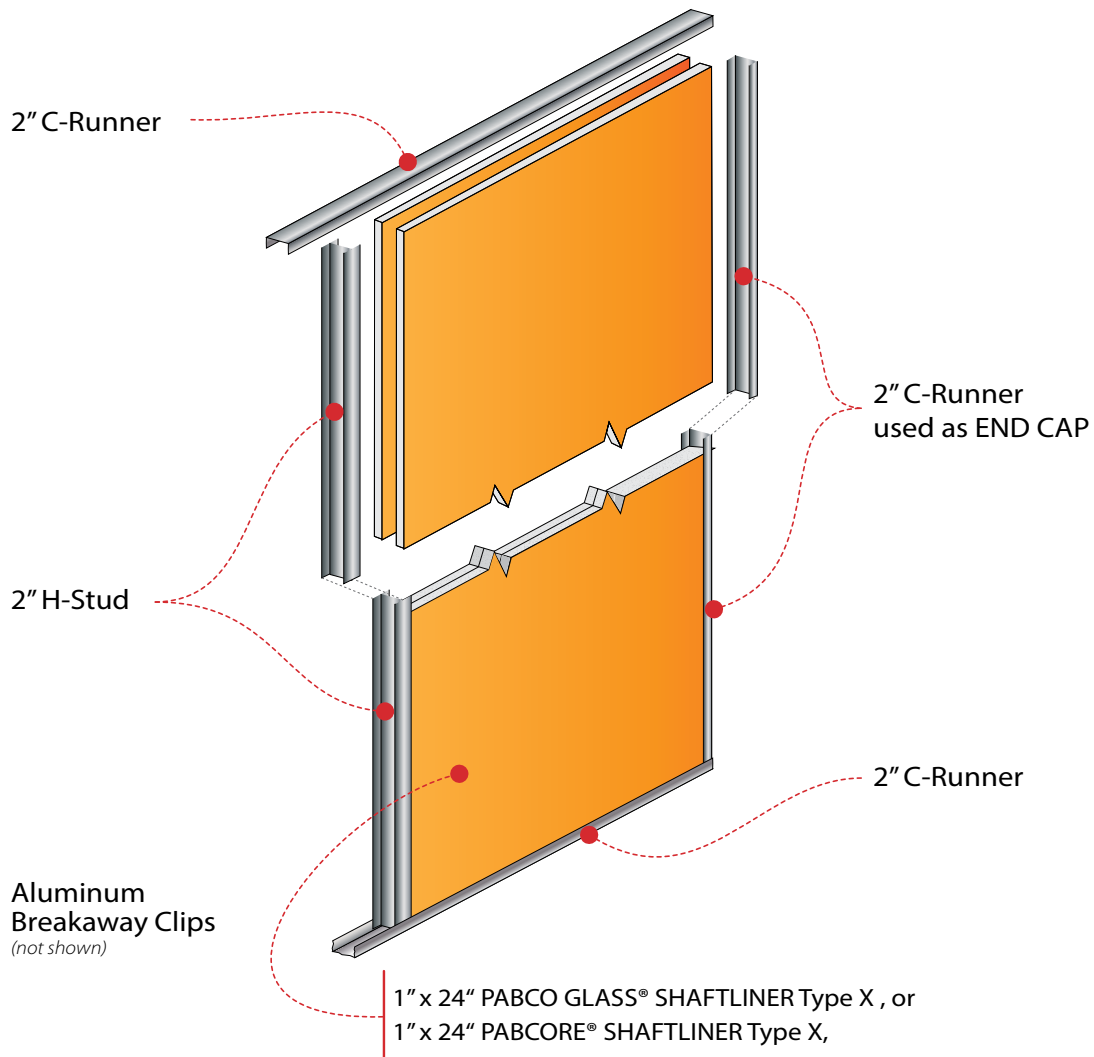

ASW Components

Fasteners & Insulation

FASTENERS:

Pan Head Screw 1/2"

- Attaching L-shaped aluminum breakaway clip to H-Stud
- Attaching horizontal C-Runner track to vertical C-Runner perimeter tracks
- Attaching back-back C-Runner tracks

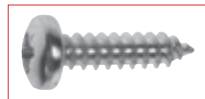

Type W Drywall Screw 1-1/4"

- Attaching L-shaped aluminum breakaway clip to wood framing and for attaching gypsum panel to flanking wall



Drywall Nail or Screw

- Attach gypsum panel to wood studs and bearing plates of the adjacent wall



Steel Nail 16d

- Assembly of adjacent wood framing



ACOUSTIC INSULATION:

- Acoustic insulation for wall cavity as specified

FIREBLOCKING:

- Mineral wool batt fire barrier is used where the ASW membrane meets external walls and roofs

H-Stud ASW Features, Uses and Limitations

USES:

- The H-Stud ASW is a non-load bearing partition
- Specifically designed as a 2-hour wall separating units in multifamily construction
- May be used in buildings up to a total height not to exceed 66 feet
- The H-stud ASW is designed to be laterally supported with aluminum clips spaced at specified intervals as defined in the "Design Requirements" section
- PABCO GLASS® Sheathing should be used for all exposed faces of stud framing of Area Separation Walls which protrude beyond the roof or side walls

LIMITATIONS:

- The H-stud ASW is not intended to be used as a shear wall
- Penetrations or openings are not permitted in the double shaftliner central wall; the non-fire-resistance rated flanking walls are permitted to be penetrated as needed to allow for utilities, ducts, or vents in the wall cavity.
- Do not install insulation in the wall system until the building has been properly closed or dried-in to protect it from the weather

FEATURES:

- Designed for fast, easy installation that can be erected by carpenter tradesmen
- The H-stud ASW can be constructed with or without a parapet, depending on roof design and local code requirements
- Provides continuous fire-resistant membrane from foundation to roof, unbroken by floor or structural members
- Provides superior sound attenuation
- The H-stud ASW can be constructed in multifamily projects up to 66 feet in height
- Weighs less than ten pounds per square foot (10 lb/ft²), resulting in a considerable weight reduction when compared to concrete block

CODE COMPLIANCE:

- For Party Walls, the H-Stud ASW must be continuous from the foundation to the underside of the roof sheathing
- For 2 hour fire walls, the H-Stud ASW must be continuous from the foundation through the roof to form a parapet. It must allow for the collapse of the construction on the fire side of the wall while remaining intact to protect the structure on its opposite side.
- In seismic design categories D-F, the H stud ASW may be penetrated by floor sheathing as required by building structural design.

Performance Testing

FIRE PROTECTION:

PABCO GLASS® Shaftliner and PABCORE® Shaftliner have been independently tested to meet the performance criteria to be classified as Type X gypsum panels by Underwriters Laboratories in accordance with ASTM C1396 and E119 (UL 263).

The fire-resistance rating of an assembly is determined in accordance with ASTM E119 or UL 263 and performed at IAS* certified independent testing laboratories.

The PABCO® H-Stud ASW system has been extensively tested as a complete system to ensure long-term performance. The substitution of components in the system could adversely affect the overall performance of the system. Precaution shall be taken that assembly procedures are in accordance with those of good design practices.

| Shaftliner Type | Industry Standard | Combustibility | Structural | Fire Rated Assemblies | STC Rating |
|----------------------------------|-------------------|-----------------|------------------|------------------------------------|-----------------------|
| PABCO GLASS® Shaftliner - Type X | ASTM 1658 | Non-Combustible | Non-load bearing | WFCi #, 07073, 19045a, 20011 | 60-64 RAL-TL07-373 |
| PABCORE® Shaftliner - Type X | ASTM 1396 | | | | |

SOUND ATTENUATION:

Sound transmission is an important consideration as open floor plans, home theaters, and media rooms become more prevalent which increase the sound being transmitted between units through the party walls. The acoustic test data demonstrates the effectiveness of PABCO® Gypsum’s Area Separation Wall in sound attenuation; thereby, ensuring additional privacy to occupants of adjacent dwellings. STC ratings up to 64 are available.

MOLD & MOISTURE RESISTANCE:

PABCO GLASS® Shaftliner is manufactured using advanced gypsum core and facer chemistries designed with special fungicides to promote long-term mold resistance. PABCO® Gypsum was the first in the industry to have completed a long-term mold resistance aging study of the MOLD CURB® Plus product family. After two years of exposure to varying temperature and humidity conditions, MOLD CURB® Plus products continued to inhibit mold growth with a perfect score of ten (10) when tested in accordance with ASTM D273.

For information regarding system requirements, contact the PABCO® Gypsum Technical Services team at 1-866-282-9298.

Design Requirements

SYSTEM REQUIREMENTS:

- Note: the zero (0') elevation point of an ASW is the top of the wall. Distance is measured downward from the top.
- When the total height of the ASW is less than forty-four feet (44'), the vertical spacing of the aluminum breakaway clips shall not exceed five feet (5'). Reference WFCI Report #20011 dated August 18, 2020.
- When the total height of the ASW is greater than forty-four feet (44') but less than or equal to sixty-six feet (66'), the vertical spacing of the ASW below the forty-four foot mark (44') shall not exceed thirty-nine inches (39"). Reference WFCI Report #19045a dated August 21, 2019.
- The maximum height of the PABCO® ASW assembly shall not exceed sixty-six feet (66').
- When the ASW system is used as an exterior with adjacent framing on only one side, two (2) 1/2" Type S pan head screws are required for the clip attachment.
- Caulk all gaps between back-to-back C-Tracks with an approved fire caulking material.
- There shall be no penetrations allowed in the one-inch shaftliner panels.

ALUMINUM BREAK-AWAY CLIP REQUIREMENTS:

- Only use aluminum L-shaped clips to attach the H-stud ASW to the adjacent framing members. In the event of a fire, the break-away clip is designed to melt, allowing the fire-side framing members to fall away leaving the two layers of 1" PABCO® shaftliner intact.
- L-shaped aluminum clips are attached to each side of every H-stud (2 per stud) with two (2) 1/2" Type S pan head screws through the short leg of the clip. Secure the long leg of the clip to wood framing with one (1) 1-1/4" Type W screw.
- When the total height of the ASW is 44 feet or less, the spacing of the breakaway clips is shall not exceed 5 feet on center.
- When the total height of the ASW is taller than 44 feet and up to a maximum of 66 feet tall, the lateral bracing of the breakaway clips shall be spaced no more than 39 inches on center.
- In the event that the H-stud does not align with the adjacent wood framing, insert blocking between wood framing members and attach aluminum clip to the blocking.

ACOUSTIC SEALING REQUIREMENTS:

- Use an approved acoustical sealant and seal all penetrations, the entire perimeter of wall/floor junctions, and the horizontal back-to-back C-runners with a minimum 1/4" bead of acoustical sealant.
- Membrane vertical T junction perimeters shall be sealed for flanking noise using mineral wool insulation between vertical capping track and the external wall.
- To maintain acoustic specifications, service penetrations through wood substrate framing should not be in contact with the ASW membrane, studs, tracks or clips.
- All penetrations in flanking wall shall be sealed by applying an acoustical sealant.

Design Details

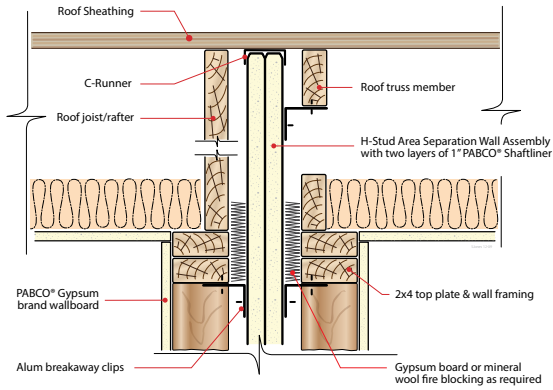

TYPICAL ROOF INTERSECTION DETAIL
Elevation View

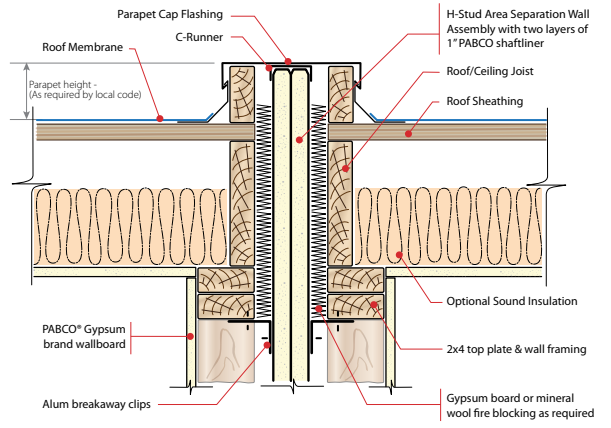

TYPICAL ROOF INTERSECTION PARAPET DETAIL
Elevation View

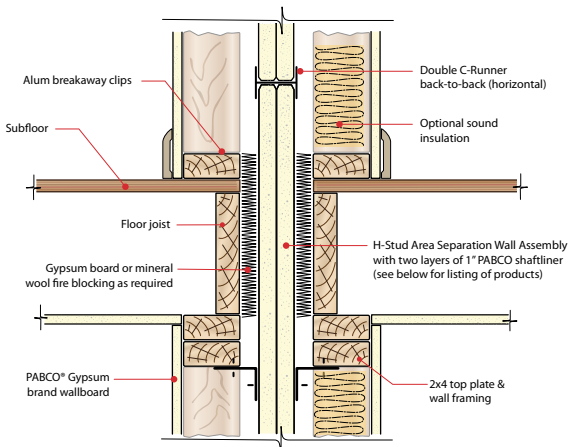

TYPICAL INTERMEDIATE FLOOR DETAIL
Elevation View

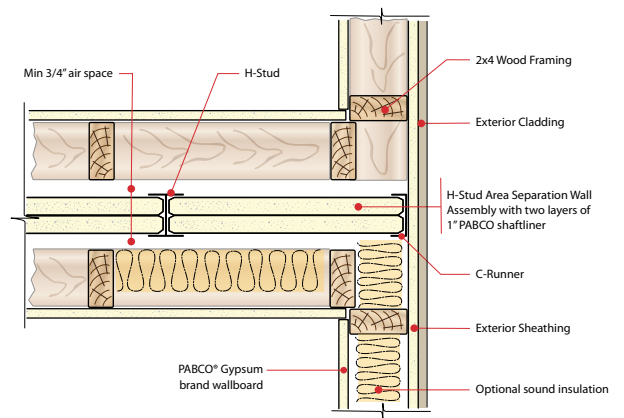

EXTERIOR WALL INTERSECTION DETAIL
Plan View

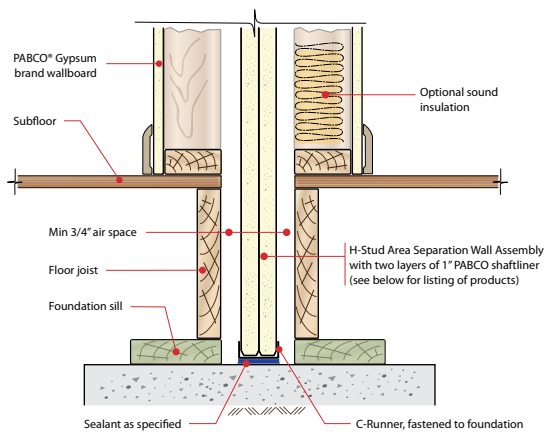

TYPICAL FOUNDATION DETAIL
Elevation View

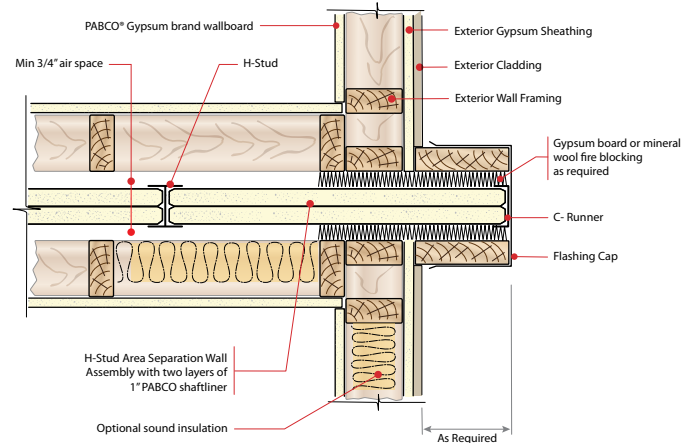

PROTRUDING EXTERIOR WALL INTERSECTION DETAIL
Plan View

Installation of H-Stud Area Separation Walls

APPLICATION

For structures not located in seismic design categories D-F, H-stud Area Separation Walls (ASW) are installed either from above grade, top of masonry or concrete footings, and extend, uninterrupted, either to or through the roof deck; or from the foundation floor (slab) and extend, uninterrupted. The H-stud ASW is progressively erected one floor at a time with each succeeding floor being stacked on top of the preceding floor.

Each floor height is run from one exterior wall at inside of cladding to the opposite exterior wall inside of cladding creating separate structures.

For structures located in seismic design categories D-F and when specified on plans, H-stud Area Separation wall may be interrupted by continuous floor sheathing up to 3/4 inch in thickness (IBC 706.2).

INSTALLATION

A: Foundation Floor:

Position a 2-inch C-runner and securely attach to concrete floor with power-driven fasteners at both ends and spaced 24-inches O.C. along length. Space runner sections 1/4-inch apart. Caulk under runner at foundation floor with a minimum of 1/4-inch bead of QuietSeal® Pro acoustical sealant.

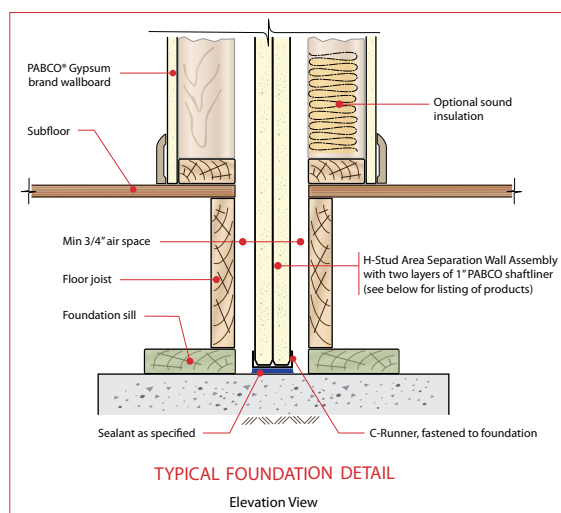

Note: C-runner must be positioned a minimum of 3/4-inch from adjacent framed interior wall that will support the aluminum breakaway clips.

B. First Floor

Install H-studs and liner panels to a convenient height (max. 2 inches above the floor line). Install two thicknesses of 1-inch shaftliner panels vertically in C-runner with long edges in H-stud. Install H-studs and liner panels alternately until wall is completed. Cap top of wall section with horizontal C-runner. Fasten C-runner flanges at all corners both sides with 1/2-inch Pan Head Type S screws.

When exterior cladding is not in place, position 2-inch C-runner end caps over each end of liner panels and fasten at both sides of each C-runner at the top and floor of wall using 1/2-inch Pan Head Type S screws. When exterior cladding is in place, caulk under the C-Runner that will meet the inside of the exterior wall, attach the C-runner to bottom and top of the wall section.

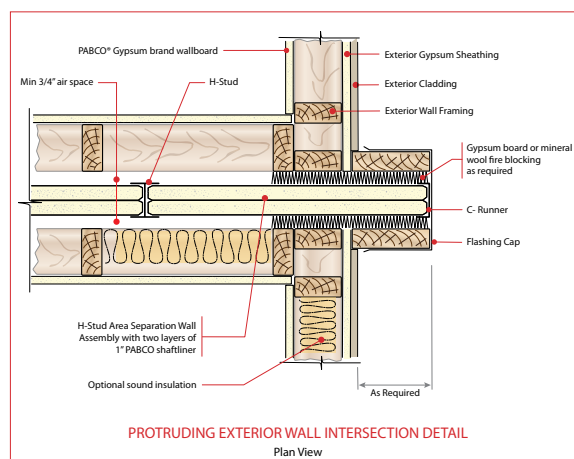
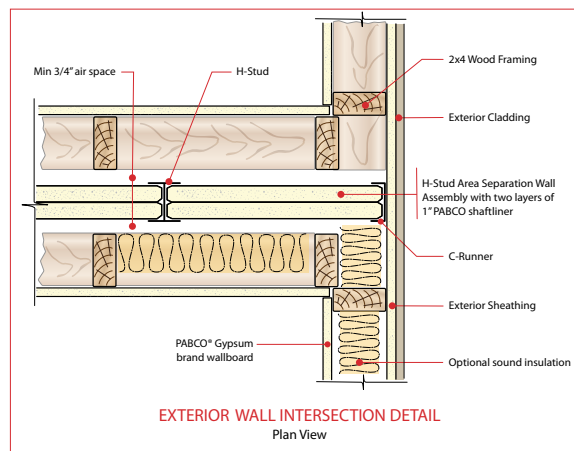

Installation of H-Stud Area Separation Walls

C. Intermediate Floors and Bottom of Trusses

Attach C-runner for next row of panels to the C-runner below with end joints staggered at least 12 inches. Fasten the C-runners together with double 1/2-inch Pan Head Type S screws at ends and 24-inches O.C. Attach all H-studs and vertical C-runners to adjacent framing with aluminum breakaway clips at the spacing required for the aluminum breakaway clip location on the ASW height.

Aluminum breakaway clips attaching H-studs and vertical C-runners to adjacent framing on both sides require attachment to the H-stud and vertical C-runner with one 1/2-inch Pan Head Type S screw.

Aluminum breakaway clips attaching H-studs and vertical C-runners to adjacent framing on only one side and with exterior exposure on the other side require attachment to the H-stud and C-runner with two 1/2-inch Pan Head Type S screws.

Aluminum breakaway clip attachment to the flanking wall is accomplished utilizing one 1-1/4" Type W or Type S screw either in a vertical orientation to the flanking wall stud or in a horizontal orientation to blocking across the stud cavity.

Locate horizontal C-runner joint within 2 inches of the intermediate floor. Install fire blocking between the solid wall system and adjacent framing at floor lines, bottom of truss line, and any other locations required by the applicable code.

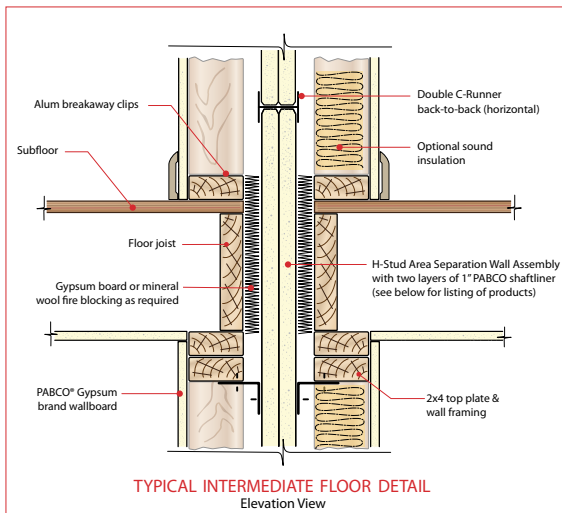

D. Roof

Continue installing H-studs and liner panels for succeeding floor as described. Cut the liner panels and H-studs to roof pitch and length as necessary to follow the roof pitch. At roof, cap liner panels and H-studs with C-runner. Attach all H-studs to adjacent framing with aluminum breakaway clips. Clips attaching H-studs and vertical C-runners to adjacent framing on only one side and with exterior exposure on the other side require attachment to each vertical framing member with two 1/2-inch Pan Head Type S screws.

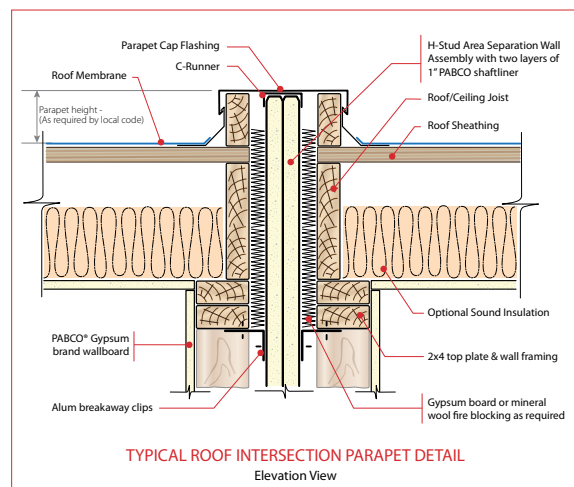
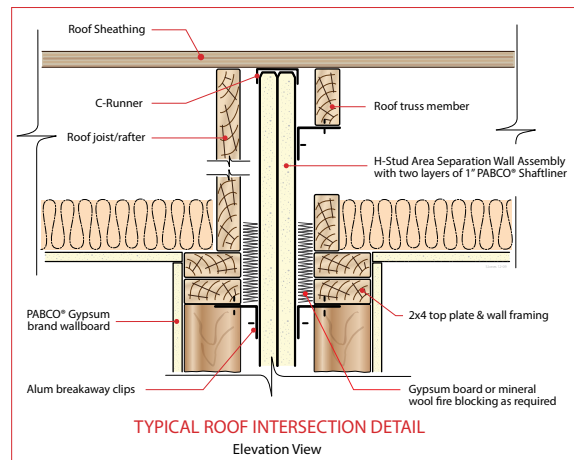

Note: When the total height of the ASW exceeds 44 feet but not more than 66-feet, the vertical spacing between the rows of the L-Shaped aluminum breakaway clips shall not exceed 39 inches. When the total height of the ASW is less than 44 feet, the vertical spacing between the rows of the L-Shaped aluminum breakaway clips shall not exceed 60-inches.

