

BASIC USES

Pecora 895 NST has been specifically designed for:

- Structural glazing of glass, metal and plastic. It may also be used as a weatherseal in structural glazing applications.
- Non-structural glazing applications including cap, toe and heel beads and as a weatherseal in glass to glass butt joint glazing.
- Sealing expansion and control joints in precast concrete panels, metal curtain walls, and natural stone.
- Perimeter sealing of doors, windows and other building components.
- Adhering stiffeners to building panels.
- Use in unitized curtain wall systems.
- Security glazing and impact resistant window systems.
- Protecting and sealing electronic equipment.

Features:

- Excellent unprimed adhesion to most surfaces including glass, reflective glass, anodized aluminum, plastics, wood, masonry, and fluoropolymer based paints.
- Long open time for ease of application and tooling.
- Extremely fast cure-through after initial set.
- Compatible with most laminated glass units and acrylic glazing sheets.
- Easily applied (gunnable) at all working temperatures.
- Will not corrode building components.
- Low VOC
- Mild odor.
- Suitable for use on natural stones such as limestone, granite or marble.
- Excellent electrical insulation properties when used in electronic applications.
- To seal polycarbonate substrates. Consult Pecora Technical Service for recommendations.
- To seal exterior insulation finish systems (EIFS).
- To seal horizontal joints in decks, walks, driveways, etc. subject to abrasion.
- To seal marine joints at or below the waterline.
- In totally confined or air-free spaces.
- In designs that require painting after application of sealant.
- On surfaces with special protective coatings without prior consultation with Technical Services department.
- In contact with building materials that bleed oils, plasticizers or solvents, i.e. impregnated wood, oil-based caulks, green or vulcanized rubber gaskets or tapes.
- When surface temperatures during application exceed 140°F (60°C).
- To damp or frost covered surfaces.
- 895NST Translucent (Pecora color #610) is not intended for use in 4-sided structural glazing applications.

Limitations:

Pecora 895NST should not be used in these applications or conditions:

MANUFACTURER

PECORA CORPORATION

165 Wambold Road
Harleysville, PA 19438
Phone: 215-723-6051
800-523-6688
Fax: 215-721-0286
Website: www.pecora.com

PRODUCT DESCRIPTION

Pecora 895NST is a high-performing, neutral curing, medium modulus silicone sealant specifically designed for structural and non-structural glazing, with excellent aesthetic characteristics in that it will not stain sensitive porous natural stones such as granite or marble and will not contribute to residue run down on non-porous surfaces such as metal or glass curtain wall facades. Reduction in long term dirt pick up on sealant surface is also a feature of the Pecora NST line of silicone architectural grade sealants. With a dynamic movement capability of ±50% to complement its structural strength, 895NST is equally efficient as a weatherseal in the vast majority of sealant applications other than glazing.

TABLE 1: TYPICAL UNCURED PROPERTIES (AT 77°F, (25°C), 50% RH)

Test Property	Value	Test Procedure
Flow, Sag, Slump	Nil	ASTM C639
Tool/Work Time (minutes)	15-25	Pecora Corporation
Tack Free Time (hours)	3	ASTM C679
Curing Time (days)	7-14	ASTM C679
Full Adhesion (days)	7-14	ASTM C679
VOC Content (g/L)	<50	ASTM D3960
VOC Emissions (TVOC)	Pass (All Exposure Scenarios)	CDPH v1.2-2017

TABLE 2: TYPICAL CURED PROPERTIES (AFTER 7 DAYS CURE AT 77°F, (25°C), 50% RH)

Test Property	Value	Test Procedure
Hardness, Shore A	30	ASTM D2240
Elongation (%)	700	ASTM D412
Modulus @ 100% Elongation (psi)	50	ASTM D412
Ultimate Tensile Strength (psi)	200	ASTM D412
Tear Strength (ppi)	40	ASTM D624
Peel Strength (pli) on Aluminum, Glass and Concrete	30	ASTM C794
Dynamic Movement Capability (%)	±50	ASTM C719
Ozone/UV Resistance	Excellent	ASTM D1149
Staining, Color Change	None	ASTM C510
Staining of porous substrates like marble	Pass	ASTM C1248
Service Temperature (°F)	-60 to 300	Pecora Corporation
Dielectric Constant		
#610 Translucent	2.5 @ 1kHz / 2.5 @ 10kHz	ASTM D150
#012 Black	3.1 @ 1kHz / 3.1 @ 10kHz	ASTM D150
Dissipation Factor		
#610 Translucent	0.001 @ 1kHz / 0.001 @ 10kHz	ASTM D150
#012 Black	0.007 @ 1kHz / 0.005 @ 10kHz	ASTM D150

PACKAGING

- 10.1 fl. oz. (300 ml) disposable plastic cartridges
- 20 oz. (592 ml) sausages
- 2-gallon (7.57 liters)
- 5-gallon (18.9 liter) pails
- 50-gallon (189 liter) drums

COLOR

- Black, Limestone, Precast, Charcoal Gray, Sandstone, Red Rock, Hartford Green, Tru-White, Aluminum Stone, Beige, Classic Bronze, Natural Stone, Anodized Aluminum, and Translucent
- Custom colors are available upon request. (30 gallon minimum)

TECHNICAL DATA

Applicable Standards: Pecora 895NST meets or exceeds the following: TT-S-00230C, Class A, ASTM C-920, Class 50, Type S, Grade NS, Use G,A,M,O; Type I & II, ASTM C-1184-05, AAMA 805.2, AAMA 802.3 & 808.3, ASTM C-1248 and is USDA approved in meat and poultry plants. Missile Impact Miami-Dade PA 201 and SSID 12-99, CAN/CGSB-19.13-M87.

INSTALLATION

Structural Sealant Joint Design: The design professional is responsible for the determination of the structural sealant joint dimension based on design windloads, glass sizes and anticipated thermal movement. Pecora Corporation must verify and approve joint dimensions on an individual project basis.

Basic Design Parameters Include:

- Structural sealant thickness must not be less than 1/4" (6.4 mm).
- Structural bite must not be less than structural sealant thickness.
- Structural bite must be determined using the following formula:

$$B = \frac{(W.L.) (1/2) (S)}{12 \times 20}$$

S = Short span of glass, feet

W.L. = Windload, PSF

Constant = 12

Design Stress, psi Max. = 20

B = Bite

- The structural sealant joint must be able to be filled using standard caulking practices.
- The structural joint must not move during cure.

These are preliminary guidelines only, consistent with common industry practice. See Figure 1.

FIGURE 1

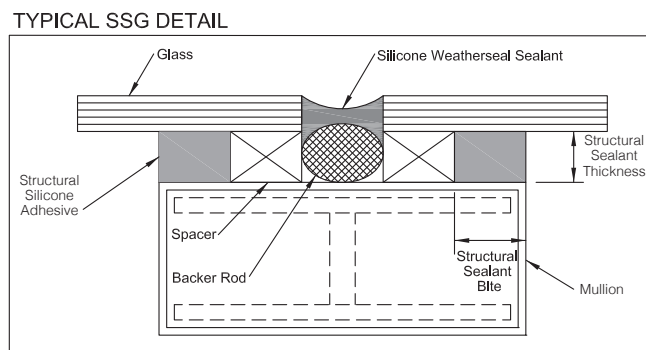
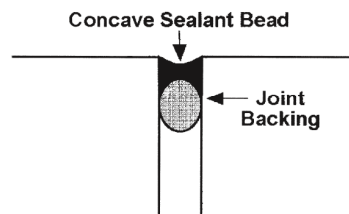
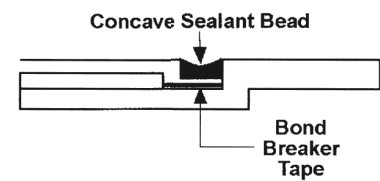

FIGURE 2

Recommended Joint Design With Joint Backing



Recommended Joint Design With Bondbreaker Tape



Lap-Shear Joints should have a bead which is equal to, or greater than, the total anticipated movement.

FIGURE 3

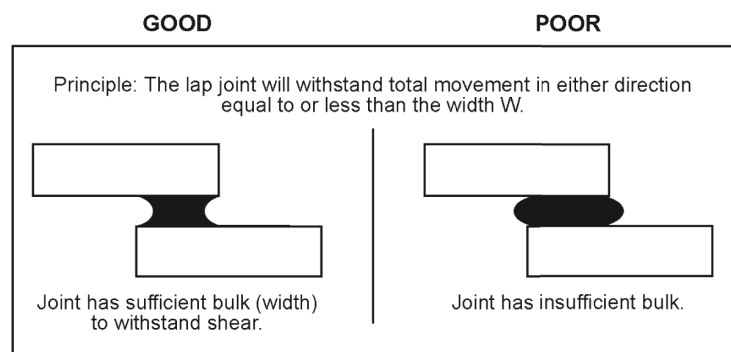

Weatherseal Joint Designs:

Proper sealant dimensions are critical when installing elastomeric joint sealants. Generally, a sealant width-to-depth ratio of 2:1 is recommended. Dynamic joint conditions will require a minimum 1/4" width and 3/16" depth in order to maintain the sealant's movement capabilities. For joints greater than 1", consult Technical Services. Open-cell polyurethane foam or closed-cell polyethylene are the recommended back up materials for most joints; use polyethylene tape for joints too shallow to allow backer rod. See Figure 2. These materials permit application of a thin bead and act as bond breakers, which allow the silicone sealant to stretch freely with the joint.

*Use a size that will compress 25% when inserted into the joint. When using closed cell polyethylene foam, extra care must be taken not to puncture the rod which can cause outgassing and bubbling/blistering in the sealant.

The width of building expansion joints varies because of seasonal and daily changes in temperature. If Pecora 895NST silicone building sealant cannot be installed when the design width is approximately halfway between the dimensional extremes, the design joint must be at least twice the total anticipated joint movement. Good architectural practice calls for joint design of four times the anticipated movement due to construction tolerances and material variations.

Glazing rabbets and joints should be designed to allow installation and retention of the bond-breaking, back-up material during the installation and curing of Pecora 895NST silicone building sealant.

Lap shear joints should have a bead width which is equal to or greater than the total

anticipated movement. See Figure 3. Small curtainwall panels and lites should allow a minimum width of 1/8" (3.2 mm) for the sealant bead. Larger panels and lites which expect a great deal of movement, should allow a minimum width of 3/16" to 1/4" for the sealant bead. Glazing of plastic lites and sealing of wall panels fabricated of plastics require larger than usual joint dimensions due to the greater movement potential caused by plastic's higher coefficients of thermal expansion.

Detail 1

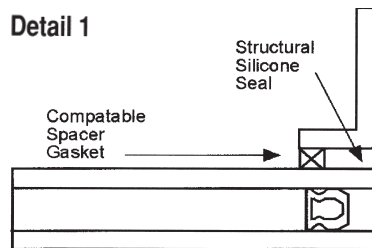

DETAIL #1 is commonly used in shop glazed applications where a glazing insert or split mullion is used. Care should be taken in applying the structural sealant to avoid direct contact with the insulating glass edge seal. The cure by-products are free to dissipate into the surrounding atmosphere and would not be entrapped in direct contact with the silicone I/G seal.

Detail 2

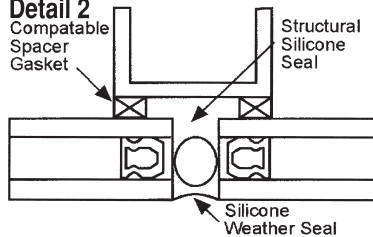

For insulating glass, the design must be changed to accommodate Figure 1 and Detail 2, unless a one component silicone secondary seal is used.

Surface Preparation: No sealant will maintain long-term adhesion to any substrate if the surface is not prepared and cleaned properly before the sealant is applied. Thoroughly clean all joints and glazing areas by removing all foreign matter and contaminants such as oil, dust, grease, frost, water, surface dirt, old sealants or glazing compounds and any protective coating. Porous substrates and precast concrete panels using form release agents other than polyethylene film should be cleaned by grinding, saw cutting, blast cleaning (water or sand), mechanical abrading or a combination of these methods which will provide a sound, clean and dry surface for sealant application. Dust, loose particles, etc. should be blown out of joints with oil-free compressed air or vacuum cleaned by a solvent procedure or by mechanical means. Soap or detergent and water cleaning treatments are not recommended. Cleaning of all surfaces should be done just prior to the sealant application.

NOTE: Structural glazing requires even greater attention to surface cleaning and preparation. Pecora Technical Bulletin No. 56 on structural glazing addresses these procedures in much greater detail.

Priming: Pecora 895NST does not require priming on most common substrates. Unusual building materials, special coatings and treatments of surfaces may impair optimum adhesion. Due to the unpredictable nature of these surfaces, a field test is recommended to determine the adhesion of 895NST silicone with or without a primer. Where primer is indicated, P-150 primer should be used on porous substrates and P-120 on metal. All precast substrates require priming with P-225 primer.

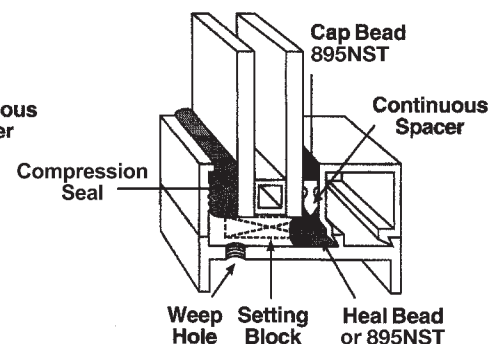
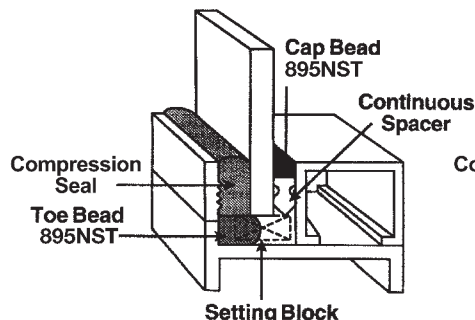
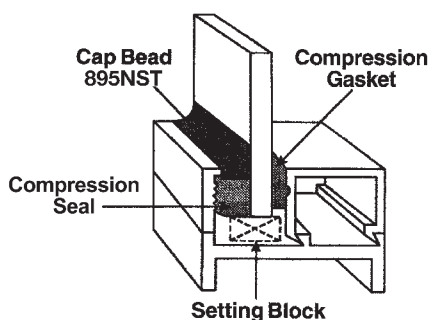

NOTE: Priming is never a substitute for proper surface cleaning and preparation. To assist in this determination, Pecora has a list of adhesion-peel-test results on a wide variety of substrates and building materials which is available on request from Technical Services.

Pecora routinely conducts project specific adhesion and compatibility testing in its laboratory on representative substrate samples. Consult Technical Services for details.

Masking: Areas adjacent to joints should be masked to assure neat sealant line. Do not allow tape to touch clean surfaces to which sealant is to adhere.

Application: Install back-up fillers, setting blocks, spacer shims and tapes as specified. Apply 895NST silicone in one continuous operation. Tool sealant at once after application before skin forms. Tool concave with a firm continuous stroke to assure complete sealant contact with the substrate and present a neat appearance. Remove masking tape.

In glazing applications be sure that the sealant is tooled at the sills so that precipitation and cleaning solutions will not pool.

For cold temperature applications of Pecora 895NST refer to Pecora Cold Temperature Application Technical Bulletin #65.

Clean Up: Immediately remove all excess sealant and smears adjacent to joints with mineral spirits. Also use mineral spirits for removing uncured sealant from equipment. Remove cured sealant by scraping, sandpapering, etc. (Caution: mineral spirits is flammable and toxic. Observe manufacturer's precautions.)

Tool Time: 15-25 minutes at 77°F, 50% relative humidity. Higher temperatures and humidity will shorten this time.

Shelf Life: Pecora 895NST Silicone has a shelf life of twelve months from date of manufacture when stored in unopened cartridges or sausages at temperatures lower than 80° F (27° C), or nine months in tightly-sealed bulk packages.

Precautions: Use with adequate ventilation or wear an appropriate NIOSH-approved respirator. Contact with uncured sealant or with vapors generated during curing may cause respiratory tract irritation. Contact with skin or eyes may cause irritation or allergic reaction. Avoid contact and wash thoroughly after handling. May be harmful if swallowed. Refer to Safety Data Sheet (SDS) for more information.

**FOR PROFESSIONAL USE ONLY.
KEEP OUT OF THE REACH
OF CHILDREN.**

AVAILABILITY AND COST

Pecora products are available from stocking distributors nationwide. For the name and telephone number of your nearest representative, call the number below or visit our website at www.pecora.com.

WARRANTY

Pecora Corporation warrants its products to be free of defects. Under this warranty, we will provide, at no charge, replacement materials for, or refund the purchase price of, any product proven to be defective when used in strict accordance with our published recommendations and in applications considered by us as suitable for this product. The determination of eligibility for this warranty, or the choice of remedy available under this warranty, shall be made in our sole discretion and any decisions made by Pecora Corporation shall be final. This warranty is in lieu of any and all other warranties, expressed or implied, including but not limited to a warranty of merchantability or fitness for a particular purpose and in no case will Pecora be liable for damages other than those expressly stated in this warranty, including but not limited to incidental or consequential damages.

MAINTENANCE

If the sealant is damaged and the bond is intact, cut out the damaged area and recaulk. No primer is necessary. If the bond has been affected, remove the sealant, clean and prepare the joint in accordance with instructions under "INSTALLATION".

TECHNICAL SERVICES

Pecora representatives are available to assist you in selecting an appropriate product and to provide on-site application instructions or to conduct jobsite inspections. For further information and assistance, please call our Technical Services department at 215-723-6051 or 800-523-6688.

FILING SYSTEMS

- CSI MasterFormat Designations:
 - 07 92 00: Joint Sealants
 - 08 85 00: Glazing Accessories



For most recent updates, please visit our website at www.pecora.com

Pecora is a member of and supports: SWRI, CSI, AIA, ICRI, ABAA, USGBC, IPI. Pecora products are proudly made in America.

165 Wambold Road, Harleysville, PA 19438 | 800.523.6688 | pecora.com