

Strong-Bolt® 2 Wedge Anchor — Zinc-Plated Carbon Steel

Code listed for cracked and uncracked concrete, and masonry applications, the Strong-Bolt 2 wedge-type expansion anchor is an optimal choice for high-performance even in seismic and high-wind conditions. Dual undercutting embossments on each clip segment enable secondary expansion should a crack form and intersect the anchor location; this feature significantly increases the ability of Strong-Bolt 2 to carry load if the hole expands.

Features

- Chamfered top designed to prevent mushrooming during installation
- Qualified for static and seismic loading conditions (seismic design categories A through F)
- Suitable for horizontal, vertical and overhead applications
- Qualified for minimum concrete thickness of 3¼", and lightweight concrete-over-steel deck
- Standard (ANSI) fractional sizes: fits standard fixtures and installs with common drill bit and tool sizes
- Tested per ACI355.2 and AC193

Material: Carbon steel

Coating: Zinc plated

Codes: ICC-ES ESR-3037 (concrete); IAPMO UES ER-240 (carbon steel in CMU); City of LA Supplement within ESR-3037 (concrete); City of LA Supplement within ER-240 (carbon steel in CMU); Florida FL15730 (concrete); FL16230 (masonry); UL File Ex3605; FM 3043342 and 3047639; Multiple DOT listings; meets the requirements of Federal Specifications A-A-1923A, Type 4

Installation

 Do not use an impact wrench to set or tighten the Strong-Bolt 2 anchor.

 **Caution:** Oversized holes in the base material will make it difficult to set the anchor and will reduce the anchor's load capacity.

1. Drill a hole in the base material using a carbide drill bit the same diameter as the nominal diameter of the anchor to be installed. Drill the hole to the specified minimum hole depth, and blow it clean using compressed air. (Overhead installations need not be blown clean.) Alternatively, drill the hole deep enough to accommodate embedment depth and dust from drilling.
2. Assemble the anchor with nut and washer so the top of the nut is flush with the top of the anchor. Place the anchor in the fixture, and drive it into the hole until the washer and nut are tight against the fixture.
3. Tighten to the required installation torque.



**Strong-Bolt 2
Wedge Anchor**



Head Stamp

The head is stamped with the length identification letter, bracketed top and bottom by horizontal lines.

Strong-Bolt® 2 Wedge Anchor — Zinc-Plated Carbon Steel

Installation Sequence

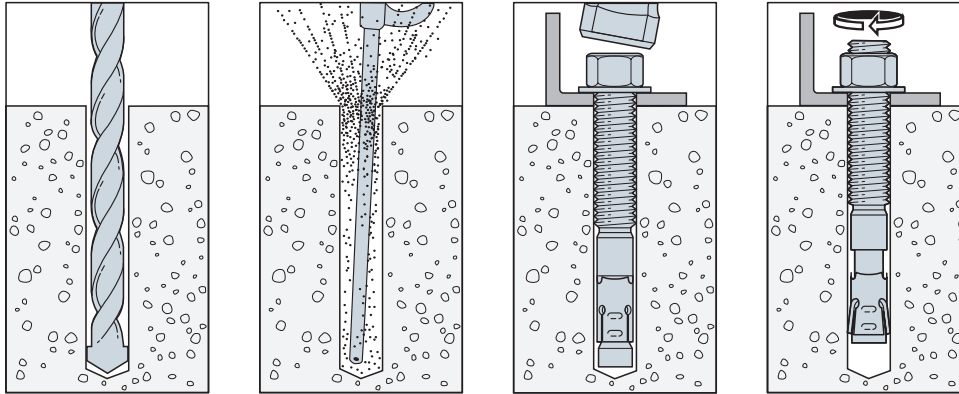

Material Specifications

| Anchor Body | Nut | Washer | Clip |
|--------------|-----------------------------------|------------------------|--------------------------|
| Carbon Steel | Carbon Steel, ASTM A 563, Grade A | Carbon Steel ASTM F844 | Carbon Steel, ASTM A 568 |

Strong-Bolt 2 Anchor Installation Data

| Strong-Bolt 2 Diameter (in.) | 1/4 | 3/8 | 1/2 | 5/8 | 3/4 | 1 |
|--|------|------|------|-------|-------|-------|
| Drill Bit Size (in.) | 1/4 | 3/8 | 1/2 | 5/8 | 3/4 | 1 |
| Min. Fixture Hole (in.) | 5/16 | 7/16 | 9/16 | 11/16 | 7/8 | 1 1/8 |
| Wrench Size (in.) | 7/16 | 9/16 | 3/4 | 15/16 | 1 1/8 | 1 1/2 |
| Concrete Installation Torque (ft.-lbf) Carbon Steel | 4 | 30 | 60 | 90 | 150 | 230 |

Length Identification Head Marks on Strong-Bolt 2 Wedge Anchors (corresponds to length of anchor — inches)

| Mark | Units | A | B | C | D | E | F | G | H | I | J | K | L | M | N | O | P | Q | R | S | T | U | V | W | X | Y | Z |
|-------------------------|-------|-------|-------|-------|-------|-------|-------|-------|-------|-------|-------|-------|-------|-------|-------|-------|-------|-------|----|----|----|----|----|----|----|----|----|
| From | in. | 1 1/2 | 2 | 2 1/2 | 3 | 3 1/2 | 4 | 4 1/2 | 5 | 5 1/2 | 6 | 6 1/2 | 7 | 7 1/2 | 8 | 8 1/2 | 9 | 9 1/2 | 10 | 11 | 12 | 13 | 14 | 15 | 16 | 17 | 18 |
| Up To But Not Including | in. | 2 | 2 1/2 | 3 | 3 1/2 | 4 | 4 1/2 | 5 | 5 1/2 | 6 | 6 1/2 | 7 | 7 1/2 | 8 | 8 1/2 | 9 | 9 1/2 | 10 | 11 | 12 | 13 | 14 | 15 | 16 | 17 | 18 | 19 |

Strong-Bolt® 2 Wedge Anchor — Zinc-Plated Carbon Steel

Strong-Bolt 2 Anchor Product Data — Zinc-Plated Carbon Steel

| Size (in.) | Zinc-Plated Carbon Steel Model No. | Drill Bit Diameter (in.) | Thread Length (in.) | Quantity | |
|------------|------------------------------------|--------------------------|---------------------|----------|--------|
| | | | | Box | Carton |
| ¼ x 1¾ | STB2-25134† | ¼ | 1⅝ | 100 | 500 |
| ¼ x 2¼ | STB2-25214 | ¼ | 1⅞ | 100 | 500 |
| ¼ x 3¼ | STB2-25314 | ¼ | 2⅞ | 100 | 500 |
| ⅜ x 2¼ | STB2-37214R50 | ⅜ | 1 | 50 | 250 |
| ⅜ x 2¾ | STB2-37234 | ⅜ | 1⅝ | 50 | 250 |
| ⅜ x 3 | STB2-37300 | ⅜ | 1⅞ | 50 | 250 |
| ⅜ x 3½ | STB2-37312 | ⅜ | 2⅞ | 50 | 250 |
| ⅜ x 3¾ | STB2-37334 | ⅜ | 2⅞ | 50 | 250 |
| ⅜ x 5 | STB2-37500 | ⅜ | 3⅞ | 50 | 200 |
| ⅜ x 7 | STB2-37700 | ⅜ | 5⅝ | 50 | 200 |
| ½ x 2¾ | STB2-50234R25† | ½ | 1¼ | 25 | 125 |
| ½ x 3¾ | STB2-50334 | ½ | 2⅞ | 25 | 100 |
| ½ x 4¼ | STB2-50414 | ½ | 2⅞ | 25 | 100 |
| ½ x 4¾ | STB2-50434 | ½ | 3⅞ | 25 | 100 |
| ½ x 5½ | STB2-50512 | ½ | 3⅞ | 25 | 100 |
| ½ x 7 | STB2-50700 | ½ | 5⅝ | 25 | 100 |
| ½ x 8½ | STB2-50812 | ½ | 6 | 25 | 100 |
| ½ x 10 | STB2-50100 | ½ | 6 | 25 | 100 |
| ½ x 12 | STB2-501200R10 | ½ | 6 | 10 | 20 |
| ⅝ x 3½ | STB2-62312R20† | ⅝ | 1⅝ | 20 | 80 |
| ⅝ x 4½ | STB2-62412 | ⅝ | 2⅞ | 20 | 80 |
| ⅝ x 5 | STB2-62500 | ⅝ | 2⅝ | 20 | 80 |
| ⅝ x 6 | STB2-62600 | ⅝ | 3⅝ | 20 | 80 |
| ⅝ x 7 | STB2-62700 | ⅝ | 4⅝ | 20 | 80 |
| ⅝ x 8½ | STB2-62812 | ⅝ | 4⅝ | 20 | 80 |
| ⅝ x 10 | STB2-62100 | ⅝ | 6 | 20 | 40 |
| ⅝ x 12 | STB2-621200R10 | ⅝ | 6 | 10 | 20 |
| ¾ x 4¾ | STB2-75434R10† | ¾ | 2⅝ | 10 | 40 |
| ¾ x 5½ | STB2-75512 | ¾ | 3⅞ | 10 | 40 |
| ¾ x 6¼ | STB2-75614 | ¾ | 3⅝ | 10 | 40 |
| ¾ x 7 | STB2-75700 | ¾ | 4⅞ | 10 | 40 |
| ¾ x 8½ | STB2-75812 | ¾ | 6 | 10 | 20 |
| ¾ x 10 | STB2-75100 | ¾ | 6 | 10 | 20 |
| ¾ x 12 | STB2-751200R5 | ¾ | 6 | 10 | 20 |
| 1 x 7 | STB2-100700 | 1 | 3½ | 5 | 20 |
| 1 x 10 | STB2-1001000 | 1 | 3½ | 5 | 10 |
| 1 x 13 | STB2-1001300 | 1 | 3½ | 5 | 10 |

† Does not meet minimum embedment in code report.

Strong-Bolt® 2 Design Information — Concrete



Zinc-Plated Carbon-Steel Strong-Bolt 2 Installation Information and Additional Data¹

| Characteristic | Symbol | Units | Nominal Anchor Diameter, d_a (in.) | | | | | | | | | | | | | | | |
|--|---------------|------------------|--------------------------------------|------------------|-------|---------------------|--------|-------|---------------------|--------|-------|----------------------|---------|----------------|---------|-------|---------|--------|
| | | | 1/4 ⁴ | 3/8 ⁵ | | 1/2 ⁵ | | | 5/8 ⁵ | | | 3/4 ⁵ | | 1 ⁵ | | | | |
| Installation Information | | | | | | | | | | | | | | | | | | |
| Nominal Diameter | d_a | in. | 1/4 | 3/8 | | 1/2 | | | 5/8 | | | 3/4 | | 1 | | | | |
| Drill Bit Diameter | d | in. | 1/4 | 3/8 | | 1/2 | | | 5/8 | | | 3/4 | | 1 | | | | |
| Baseplate Clearance Hole Diameter ² | d_c | in. | 5/16 | 7/16 | | 9/16 | | | 11/16 | | | 7/8 | | 1 1/8 | | | | |
| Installation Torque | T_{inst} | ft-lbf | 4 | 30 | | 60 | | | 90 | | | 150 | | 230 | | | | |
| Nominal Embedment Depth | h_{nom} | in. | 1 3/4 | 1 7/8 | 2 7/8 | 2 1/4 ⁶ | 2 3/4 | 3 7/8 | 2 3/4 ⁶ | 3 3/8 | 5 1/8 | 3 3/8 ⁶ | 4 1/8 | 5 3/4 | 5 1/4 | 9 3/4 | | |
| Effective Embedment Depth | h_{ef} | in. | 1 1/2 | 1 1/2 | 2 1/2 | 1 3/4 | 2 1/4 | 3 3/8 | 2 1/8 | 2 3/4 | 4 1/2 | 2 5/8 | 3 3/8 | 5 | 4 1/2 | 9 | | |
| Minimum Hole Depth | h_{hole} | in. | 1 7/8 | 2 | 3 | 2 1/2 | 3 | 4 1/8 | 3 | 3 5/8 | 5 3/8 | 3 5/8 | 4 3/8 | 6 | 5 1/2 | 10 | | |
| Minimum Overall Anchor Length | ℓ_{anch} | in. | 2 1/4 | 2 3/4 | 3 1/2 | 2 3/4 | 3 3/4 | 5 1/2 | 3 1/2 | 4 1/2 | 6 | 4 3/4 | 5 1/2 | 7 | 7 | 13 | | |
| Critical Edge Distance | c_{ac} | in. | 2 1/2 | 6 1/2 | 6 | 6 | 6 | 6 | 7 1/2 | 7 1/2 | 7 1/2 | 9 | 6 | 6 | 8 | 18 | 13 1/2 | |
| Minimum Edge Distance | c_{min} | in. | 1 3/4 | 6 | | 6 | 6 | 4 | 4 | 6 1/2 | 6 1/2 | 6 1/2 | 6 1/2 | 4 1/4 | 4 1/4 | 4 1/4 | 8 | |
| | for $s \geq$ | in. | — | — | | 6 | 6 | 4 | 4 | — | — | 5 | 5 | 10 | 10 | 10 | — | |
| Minimum Spacing | s_{min} | in. | 2 1/4 | 3 | | 2 3/4 | 2 3/4 | 2 3/4 | 2 3/4 | 5 | 5 | 2 3/4 | 2 3/4 | 3 1/2 | 3 1/2 | 3 1/2 | 8 | |
| | for $c \geq$ | in. | — | — | | 12 | 12 | 12 | 12 | — | — | 8 | 8 | 6 | 6 | 6 | — | |
| Minimum Concrete Thickness | h_{min} | in. | 3 1/4 | 3 1/4 | 4 1/2 | 4 | 4 | 5 1/2 | 6 | 5 1/2 | 5 1/2 | 6 | 7 7/8 | 6 | 6 | 8 3/4 | 9 | 13 1/2 |
| Additional Data | | | | | | | | | | | | | | | | | | |
| Yield Strength | f_{ya} | psi | 56,000 | 92,000 | | 85,000 | | | | | | 70,000 | | 60,000 | | | | |
| Tensile Strength | f_{uta} | psi | 70,000 | 115,000 | | | | | | | | | | | | | 110,000 | 78,000 |
| Minimum Tensile and Shear Stress Area | A_{se} | in. ² | 0.0318 | 0.0514 | | 0.105 | | | 0.166 | | | 0.270 | | 0.472 | | | | |
| Axial Stiffness in Service Load Range — Cracked and Uncracked Concrete | β | lb./in. | 73,700 ³ | 34,820 | | 63,570 ³ | 63,570 | | 91,370 ³ | 91,370 | | 118,840 ³ | 118,840 | | 299,600 | | | |

- The information presented in this table is to be used in conjunction with the design criteria of ACI 318-19 Chapter 17, ACI 318-14 Chapter 17 or ACI 318-11 Appendix D.
- The clearance must comply with applicable code requirements for the connected element.
- The tabulated value of β is for installations in uncracked concrete only.
- The 1/4"-diameter (6.4 mm) anchor may be installed in top of uncracked normal-weight and sand-lightweight concrete over profile steel deck, where concrete thickness above upper flute meets the minimum thickness specified in this table.
- The 3/8"- through 1"-diameter (9.5 mm through 25.4 mm) anchors may be installed in top of cracked and uncracked normal-weight and sand-lightweight concrete over profile steel deck, where concrete thickness above upper flute meets the minimum thickness specified in this table for 3/8"- through 1"-diameter anchors and in the table on p. 102 for 3/8"- and 1/2"- diameter anchors.
- Tabulated values for this embedment depth are based on internal testing and they are not listed in ICC-ES ESR-3037.

*See p. 14 for an explanation of the load table icons.

Strong-Bolt® 2 Design Information — Concrete

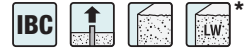

Zinc-Plated Carbon-Steel Strong-Bolt 2 Tension Strength Design Data¹

Mechanical Anchors

| Characteristic | Symbol | Units | Nominal Anchor Diameter, d _a (in.) | | | | | | | | | | | | | |
|---|---------------------------|-------|---|--------------------|--------------------|--------------------|--------------------|--------------------|--------------------|------------------|--------------------|--------------------|--------------------|--------------------|--------------------|---------------------|
| | | | 1/4 ⁷ | 3/8 ⁸ | 1/2 ⁸ | | | 5/8 ⁸ | | | 3/4 ⁸ | | 1 ⁸ | | | |
| Anchor Category | 1, 2 or 3 | — | 1 | | | | | | | | | | | | 2 | |
| Nominal Embedment Depth | <i>h_{nom}</i> | in. | 1 1/4 | 1 7/8 | 2 7/8 | 2 1/4 ⁹ | 2 3/4 | 3 7/8 | 2 3/4 ⁹ | 3 3/8 | 5 1/8 | 3 3/8 ⁹ | 4 7/8 | 5 3/4 | 5 1/4 | 9 3/4 |
| Steel Strength in Tension (ACI 318-19 17.6.1, ACI 318-14 17.4.1 or ACI 318-11 Section D.5.1) | | | | | | | | | | | | | | | | |
| Steel Strength in Tension | <i>N_{sa}</i> | lb. | 2,225 | 5,600 | 12,100 | | | 19,070 | | | 29,700 | | 36,815 | | | |
| Strength Reduction Factor — Steel Failure ^{2,3} | <i>φ_{sa}</i> | — | 0.75 | | | | | | | | | | | | 0.65 | |
| Concrete Breakout Strength in Tension (ACI 318-19 17.6.2, ACI 318-14 17.4.2 or ACI 318-11 Section D.5.2) | | | | | | | | | | | | | | | | |
| Effective Embedment Depth | <i>h_{ef}</i> | in. | 1 1/2 | 1 1/2 | 2 1/2 | 1 3/4 | 2 1/4 | 3% | 2 1/2 | 2 3/4 | 4 1/2 | 2 5/8 | 3% | 5 | 4 1/2 | 9 |
| Critical Edge Distance | <i>c_{ac}</i> | in. | 2 1/2 | 6 1/2 | 6 | 6 | 6 | 7 1/2 | 7 1/2 | 7 1/2 | 9 | 6 | 6 | 8 | 18 | 13 1/2 |
| Effectiveness Factor — Uncracked Concrete | <i>k_{uncr}</i> | — | 24 | | | | | | 27 | 24 | 27 | 24 | | | | |
| Effectiveness Factor — Cracked Concrete | <i>k_{cr}</i> | — | — ⁶ | 17 | — ¹⁰ | 17 | — ¹⁰ | 17 | — ¹⁰ | 17 | — ¹⁰ | 17 | | | | |
| Modification Factor | <i>ψ_{c,N}</i> | — | — ⁶ | 1.00 | — ¹⁰ | 1.00 | — ¹⁰ | 1.00 | — ¹⁰ | 1.00 | — ¹⁰ | 1.00 | | | | |
| Strength Reduction Factor — Concrete Breakout Failure ³ | <i>φ_{cb}</i> | — | 0.65 | | | | | | | | | | | | 0.55 | |
| Pullout Strength in Tension (ACI 318-19 17.6.3, ACI 318-14 17.4.3.1 or ACI 318-11 Section D.5.3) | | | | | | | | | | | | | | | | |
| Pullout Strength, Cracked Concrete (<i>f'_c</i> = 2,500 psi) | <i>N_{p,cr}</i> | lb. | — ⁶ | 1,300 ⁵ | 2,775 ⁵ | — ¹⁰ | N/A ⁴ | 4,985 ⁵ | — ¹⁰ | N/A ⁴ | 6,895 ⁵ | — ¹⁰ | N/A ⁴ | 8,500 ⁵ | 7,700 ⁵ | 11,185 ⁵ |
| Pullout Strength, Uncracked Concrete (<i>f'_c</i> = 2,500 psi) | <i>N_{p,uncr}</i> | lb. | N/A ⁴ | N/A ⁴ | 3,340 ⁵ | N/A ⁴ | 3,615 ⁵ | 5,255 ⁵ | N/A ⁴ | N/A ⁴ | 9,025 ⁵ | N/A ⁴ | 7,115 ⁵ | 8,870 ⁵ | 8,360 ⁵ | 9,690 ⁵ |
| Strength Reduction Factor — Pullout Failure ³ | <i>φ_p</i> | — | 0.65 | | | | | | | | | | | | 0.55 | |
| Tensile Strength for Seismic Applications (ACI 318-19 17.10.3, ACI 318-14 17.2.3.3 or ACI 318-11 Section D3.3.3) | | | | | | | | | | | | | | | | |
| Nominal Pullout Strength for Seismic Loads (<i>f'_c</i> = 2,500 psi) | <i>N_{p,eq}</i> | lb. | — ⁶ | 1,300 ⁵ | 2,775 ⁵ | — ¹⁰ | N/A ⁴ | 4,985 ⁵ | — ¹⁰ | N/A ⁴ | 6,895 ⁵ | — ¹⁰ | N/A ⁴ | 8,500 ⁵ | 7,700 ⁵ | 11,185 ⁵ |
| Strength Reduction Factor — Pullout Failure ³ | <i>φ_{eq}</i> | — | 0.65 | | | | | | | | | | | | 0.55 | |

- The information presented in this table must be used in conjunction with the design criteria of ACI 318-19 Chapter 17, ACI 318-14 Chapter 17 or ACI 318-11 Appendix D, as applicable, except as modified below.
- The 1/4"-, 3/8"-, 1/2"-, 5/8"- and 3/4"- diameter carbon steel Strong-Bolt 2 anchors are ductile steel elements as defined in ACI 318-19 2.3, ACI 318-14 2.3 or ACI 318-11 D.1, as applicable. The 1"-diameter carbon steel Strong-Bolt 2 anchor is a brittle steel element as defined in ACI 318-19 2.3, ACI 318-14 2.3 or ACI 318-11 D.1, as applicable.
- The strength reduction factor applies when the load combinations from the IBC or ACI 318 are used and the requirements of ACI 318-19 17.5.3, ACI 318-14 17.3.3 or ACI 318-11 D.4.3, as applicable, are met. If the load combinations of ACI 318-11 Appendix C are used, the appropriate strength reduction factor must be determined in accordance with ACI 318-11 D.4.4.
- N/A (not applicable) denotes that pullout resistance does not need to be considered.
- The characteristic pullout strength for greater concrete compressive strengths shall be increased by multiplying the tabular value by (*f'_c*/2,500 psi)^{0.5}.
- The 1/4"-diameter carbon steel Strong-Bolt 2 anchor installation in cracked concrete is beyond the scope of this table.
- The 1/4"-diameter (6.4 mm) anchor may be installed in top of uncracked normal-weight and sand-lightweight concrete over profile steel deck, where concrete thickness above upper flute meets the minimum thickness specified in the table on p. 99.
- The 3/8"- through 1"-diameter (9.5 mm through 25.4 mm) anchors may be installed in top of cracked and uncracked normal-weight and sand-lightweight concrete over profile steel deck, where concrete thickness above upper flute meets the minimum thickness specified in the table on p. 99 and in the table on p. 102 for the 3/8"- and 1/2"-diameter anchors.
- Tabulated values for this embedment depth are based on internal testing and they are not listed in ICC-ES ESR-3037.
- Anchor installation in cracked concrete is beyond the scope of this table for this embedment depth.

¹See p. 14 for an explanation of the load table icons.

Strong-Bolt® 2 Design Information — Concrete



Zinc-Plated Carbon-Steel Strong-Bolt 2 Shear Strength Design Data¹

| Characteristic | Symbol | Units | Nominal Anchor Diameter, d _a (in.) | | | | | | | | | | | | | | |
|---|--------------------------|-------|---|-------|------------------|--------------------|------------------|--------|--------------------|--------|------------------|--------------------|----------------|-------|-------|-------|--|
| | | | 1/4 ⁵ | | 3/8 ⁶ | | 1/2 ⁶ | | 5/8 ⁶ | | 3/4 ⁶ | | 1 ⁶ | | | | |
| Anchor Category | 1, 2 or 3 | — | 1 | | | | | | | | | | | | 2 | | |
| Nominal Embedment Depth | <i>h_{nom}</i> | in. | 1 3/4 | 1 7/8 | 2 7/8 | 2 1/4 ⁷ | 2 3/4 | 3 7/8 | 2 3/4 ⁷ | 3 3/8 | 5 1/8 | 3 3/8 ⁷ | 4 1/8 | 5 3/4 | 5 1/4 | 9 3/4 | |
| Steel Strength in Shear (ACI 318-19 17.7.1, ACI 318-14 17.5.1 or ACI 318-11 Section D.6.1) | | | | | | | | | | | | | | | | | |
| Steel Strength in Shear | <i>V_{sa}</i> | lb. | 965 | 1,800 | 5,285 | 7,235 | 2,980 | 11,035 | 10,220 | 14,480 | 15,020 | | | | | | |
| Strength Reduction Factor — Steel Failure ^{2,3} | ϕ_{sa} | — | 0.65 | | | | | | | | | | | | 0.60 | | |
| Concrete Breakout Strength in Shear (ACI 318-19 17.7.2, ACI 318-14 17.5.2 or ACI 318-11 Section D.6.2) | | | | | | | | | | | | | | | | | |
| Outside Diameter | <i>d_a</i> | in. | 0.25 | 0.375 | 0.500 | | 0.625 | | 0.750 | | 1.00 | | | | | | |
| Load-Bearing Length of Anchor in Shear | <i>ℓ_e</i> | in. | 1.500 | 1.500 | 2.500 | 1.750 | 2.250 | 3.375 | 2.125 | 2.750 | 4.500 | 2.625 | 3.375 | 5.000 | 4.500 | 8.000 | |
| Strength Reduction Factor — Concrete Breakout Failure ³ | ϕ_{cb} | — | 0.70 | | | | | | | | | | | | | | |
| Concrete Pryout Strength in Shear (ACI 318-19 17.7.3, ACI 318-14 17.5.3 or ACI 318-11 Section D.6.3) | | | | | | | | | | | | | | | | | |
| Coefficient for Pryout Strength | <i>k_{cp}</i> | — | 1.0 | | 2.0 | 1.0 | 1.0 | 2.0 | 1.0 | 2.0 | | | | | | | |
| Effective Embedment Depth | <i>h_{ef}</i> | in. | 1 1/2 | 1 1/2 | 2 1/2 | 1 3/4 | 2 1/4 | 3 3/8 | 2 1/8 | 2 3/4 | 4 1/2 | 2 5/8 | 3 3/8 | 5 | 4 1/2 | 9 | |
| Strength Reduction Factor — Concrete Pryout Failure ³ | ϕ_{cp} | — | 0.70 | | | | | | | | | | | | | | |
| Steel Strength in Shear for Seismic Applications (ACI 318-19 17.10.3, ACI 318-14 17.2.3.3 or ACI 318-11 Section D.3.3.3) | | | | | | | | | | | | | | | | | |
| Shear Strength of Single Anchor for Seismic Loads (<i>f'_c</i> = 2,500 psi) | <i>V_{sa,eq}</i> | lb. | — ⁴ | 1,800 | — ⁸ | 6,510 | — ⁸ | 9,930 | — ⁸ | 11,775 | 15,020 | | | | | | |
| Strength Reduction Factor — Steel Failure ^{2,3} | ϕ_{eq} | — | 0.65 | | | | | | | | | | | | 0.60 | | |

- The information presented in this table must be used in conjunction with the design criteria of ACI 318-19 Chapter 17, ACI 318-14 Chapter 17 or ACI 318-11 Appendix D, except as modified below.
- The 1/4"-, 3/8"-, 1/2"-, 5/8"- and 3/4"-diameter carbon steel Strong-Bolt 2 anchors are ductile steel elements as defined in ACI 318-19 2.3, ACI 318-14 2.3 or ACI 318-11 D.1, as applicable. The 1"-diameter carbon steel Strong-Bolt 2 anchor is a brittle steel element as defined in ACI 318-19 2.3, ACI 318-14 2.3 or ACI 318-11 D.1, as applicable.
- The strength reduction factor applies when the load combinations from the IBC or ACI 318 are used and the requirements of ACI 318-19 17.5.3, ACI 318-14 17.3.3 or ACI 318-11 D.4.3, as applicable, are met. If the load combinations of ACI 318-11 Appendix C are used, the appropriate strength reduction factor must be determined in accordance with ACI 318-11 D.4.4.
- The 1/4"-diameter carbon steel Strong-Bolt 2 anchor installation in cracked concrete is beyond the scope of this table.
- The 1/4"-diameter (6.4 mm) anchor may be installed in top of uncracked normal-weight and sand-lightweight concrete over profile steel deck, where concrete thickness above upper flute meets the minimum thickness specified in the table on p. 99.
- The 3/8"- through 1"-diameter (9.5 mm through 25.4 mm) anchors may be installed in top of cracked and uncracked normal-weight and sand-lightweight concrete over profile steel deck, where concrete thickness above upper flute meets the minimum thickness specified in the table on p. 102.
- Tabulated values for this embedment depth are based on internal testing and they are not listed in ICC-ES ESR-3037.
- Anchor installation in cracked concrete is beyond the scope of this table for this embedment depth.

^{*}See p. 14 for an explanation of the load table icons.

Strong-Bolt® 2 Design Information — Concrete

Zinc-Plated Carbon-Steel Strong-Bolt 2 Information for Installation in the Topside of Concrete-Filled Profile Steel Deck Floor and Roof Assemblies^{1,2,3,4}



| Design Information | Symbol | Units | Nominal Anchor Diameter (in.) | | | |
|---|--------------------|-------|-------------------------------|-------|-------|--------|
| | | | 3/8 | 1/2 | 3/4 | |
| Nominal Embedment Depth | h_{nom} | in. | 1 7/8 | 2 3/4 | 3 3/8 | |
| Effective Embedment Depth | h_{ef} | in. | 1 1/2 | 2 1/4 | 3 3/8 | |
| Minimum Concrete Thickness ⁵ | $h_{min,deck}$ | in. | 2 1/2 | 3 1/4 | 3 1/4 | 4 5/16 |
| Critical Edge Distance | $c_{ac,deck,top}$ | in. | 4 3/4 | 4 | 4 | 6 |
| Minimum Edge Distance | $c_{min,deck,top}$ | in. | 4 3/4 | 4 1/2 | 4 3/4 | 12 |
| Minimum Spacing | $s_{min,deck,top}$ | in. | 7 | 6 1/2 | 8 | 3 1/2 |

For SI: 1 inch = 25.4 mm; 1 lbf = 4.45N

1. Installation must comply with the table on p. 99 and Figure 1 below.
2. Design capacity shall be based on calculations according to values in the tables on pp. 100 and 101.
3. Minimum flute depth (distance from top of flute to bottom of flute) is 1 1/2".
4. Steel deck thickness shall be a minimum 20 gauge.
5. Minimum concrete thickness ($h_{min,deck}$) refers to concrete thickness above upper flute.

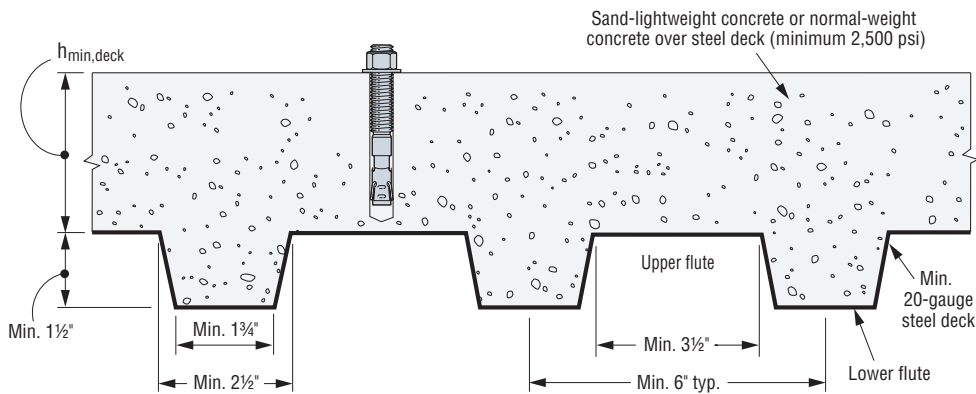

Figure 1

*See p. 14 for an explanation of the load table icons.

Strong-Bolt® 2 Design Information — Concrete

Zinc-Plated Carbon-Steel Strong-Bolt 2 Tension and Shear Strength Design Data for the Soffit of Concrete over Steel Deck Floor and Roof Assemblies^{1,2,6,8,9}



| Characteristic | Symbol | Units | Nominal Anchor Diameter (in.) | | | | | | | | |
|--|-------------------|---------|-------------------------------|--------------------|--------------------|--------------------|--------------------|--------------------|--------------------|--------------------|--------------------|
| | | | Carbon Steel | | | | | | | | |
| | | | Lower Flute | | | | | | Upper Flute | | |
| | | | % | | ½ | | ¾ | | ¾ | | % |
| Nominal Embedment Depth | h_{nom} | in. | 2 | 3% | 2¾ | 4½ | 3% | 5% | 4½ | 2 | 2¾ |
| Effective Embedment Depth | h_{ef} | in. | 1½ | 3 | 2¼ | 4 | 2¾ | 5 | 3% | 1½ | 2¼ |
| Installation Torque | T_{inst} | ft.-lbf | 30 | | 60 | | 90 | | 150 | 30 | 60 |
| Pullout Strength, concrete on steel deck (cracked) ^{3,4} | $N_{p,deck,cr}$ | lb. | 1,040 ⁷ | 2,615 ⁷ | 2,040 ⁷ | 3,645 ⁷ | 2,615 ⁷ | 4,990 ⁷ | 2,815 ⁷ | 1,340 ⁷ | 3,785 ⁷ |
| Pullout Strength, concrete on steel deck (uncracked) ^{3,4} | $N_{p,deck,uncr}$ | lb. | 1,765 ⁷ | 3,150 ⁷ | 2,580 ⁷ | 3,840 ⁷ | 3,685 ⁷ | 6,565 ⁷ | 3,800 ⁷ | 2,275 ⁷ | 4,795 ⁷ |
| Pullout Strength, concrete on steel deck (seismic) ^{3,4} | $N_{p,deck,eq}$ | lb. | 1,040 ⁷ | 2,615 ⁷ | 2,040 ⁷ | 3,645 ⁷ | 2,615 ⁷ | 4,990 ⁷ | 2,815 ⁷ | 1,340 ⁷ | 3,785 ⁷ |
| Steel Strength in Shear, concrete on steel deck ⁵ | $V_{sa,deck}$ | lb. | 1,595 | 3,490 | 2,135 | 4,580 | 2,640 | 7,000 | 4,535 | 3,545 | 5,920 |
| Steel Strength in Shear, concrete on steel deck (seismic) ⁵ | $V_{sa,deck,eq}$ | lb. | 1,595 | 3,490 | 1,920 | 4,120 | 2,375 | 6,300 | 3,690 | 3,545 | 5,330 |

- The information presented in this table must be used in conjunction with the design criteria of ACI 318-19 Chapter 19, ACI 318-14 Chapter 17 or ACI 318-11 Appendix D, except as modified below.
- The steel deck profile must comply with the configuration in Figure 2 below, and have a minimum base-steel thickness of 0.035 inch (20 gauge). Steel must comply with ASTM A 653/A 653M SS Grade 33 with minimum yield strength of 33,000 psi. Concrete compressive strength shall be 3,000 psi minimum.
- For anchors installed in the soffit of sand-lightweight or normal-weight concrete over steel deck floor and roof assemblies, calculation of the concrete breakout strength may be omitted.
- In accordance with ACI 318-19 Section 17.6.3.2.1, ACI 318-14 Section 17.4.3.2 or ACI 318-11 Section D.5.3.2, the nominal pullout strength in cracked concrete for anchors installed in the soffit of sand-lightweight or normal-weight concrete over steel deck floor and roof assemblies $N_{p,deck,cr}$ shall be substituted for $N_{p,cr}$. Where analysis indicates no cracking at service loads, the normal pullout strength in uncracked concrete $N_{p,deck,uncr}$ shall be substituted for $N_{p,uncr}$. For seismic loads, $N_{p,deck,eq}$ shall be substituted for N_p .
- In accordance with ACI 318-19 Section 17.7.1.2(c), ACI 318-14 Section 17.5.1.2(c) or ACI 318-11 Section D.6.1.2(c), the shear strength for anchors installed in the soffit of sand-lightweight or normal-weight concrete over steel deck floor and roof assemblies $V_{sa,deck}$ shall be substituted for V_{sa} . For seismic loads, $V_{sa,deck,eq}$ shall be substituted for V_{sa} .
- The minimum anchor spacing along the flute must be the greater of $3.0h_{ef}$ or 1.5 times the flute width.
- The characteristic pull-out strength for greater concrete compressive strengths shall be increased by multiplying the tabular value by $(f'_c / 3,000 \text{ psi})^{0.5}$.
- Concrete shall be normal-weight or structural sand-lightweight concrete having a minimum specified compressive strength, f'_c , of 3,000 psi.
- Minimum distance to edge of panel is $2h_{ef}$.

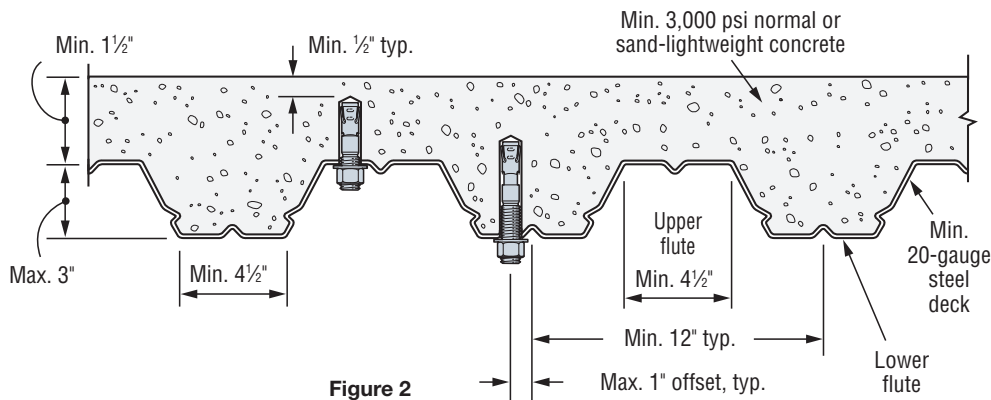
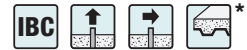

Figure 2

*See p. 14 for an explanation of the load table icons.

Strong-Bolt® 2 Design Information — Concrete

Zinc-Plated Carbon-Steel Strong-Bolt 2 Anchor Tension and Shear Strength Design Data for the Soffit of Concrete over Steel Deck, Floor and Roof Assemblies^{1,2,6,8,9}



Mechanical Anchors

| Characteristic | Symbol | Units | Carbon Steel Nominal Anchor Diameter (in.) | | | | | |
|--|-------------------|---------|--|-------|-------|-------|-------|-------|
| | | | Installed in Lower Flute | | | | | |
| | | | 3/8 | 1/2 | 5/8 | 3/4 | 4 | 5 |
| Nominal Embedment Depth | h_{nom} | in. | 2 | 3 | 4 | 5 | 6 | 7 |
| Effective Embedment Depth | h_{ef} | in. | 1 5/8 | 3 | 4 | 5 | 6 | 7 |
| Minimum Hole Depth | h_{hole} | in. | 2 1/8 | 3 1/2 | 4 | 5 | 6 | 7 |
| Minimum Concrete Thickness | $h_{min,deck}$ | in. | 2 | 2 | 2 | 3 1/4 | 2 | 3 1/4 |
| Installation Torque | T_{inst} | ft.-lbf | 30 | | 60 | | 90 | |
| Pullout Strength, concrete on steel deck (cracked) ^{3,4,7} | $N_{p,deck,cr}$ | lb. | 1,295 | 2,705 | 2,585 | 5,850 | 3,015 | 5,120 |
| Pullout Strength, concrete on steel deck (uncracked) ^{3,4,7} | $N_{p,deck,uncr}$ | lb. | 2,195 | 3,260 | 3,270 | 6,165 | 4,250 | 6,735 |
| Pullout Strength, concrete on steel deck (seismic) ^{3,4,7} | $N_{p,deck,eq}$ | lb. | 1,295 | 2,705 | 2,585 | 5,850 | 3,015 | 5,120 |
| Steel Strength in Shear, concrete on steel deck ⁵ | $V_{sa,deck}$ | lb. | 1,535 | 3,420 | 2,785 | 5,950 | 3,395 | 6,745 |
| Steel Strength in Shear, concrete on steel deck (seismic) ⁵ | $V_{sa,deck,eq}$ | lb. | 1,535 | 3,420 | 2,505 | 5,350 | 3,055 | 6,070 |

- The information presented in this table must be used in conjunction with the design criteria of ACI 318-19 Chapter 17, ACI 318-14 Chapter 17 or ACI 318-11 Appendix D, except as modified below.
- The steel deck profile must comply with the configuration in Figure 3 below, and have a minimum base-steel thickness of 0.035 inch (20 gauge). Steel must comply with ASTM A 653/A 653M SS Grade 50 with minimum yield strength of 50,000 psi. Concrete compressive strength shall be 3,000 psi minimum.
- For anchors installed in the soffit of sand-lightweight or normal-weight concrete over steel deck floor and roof assemblies, calculation of the concrete breakout strength may be omitted.
- In accordance with ACI 318-19 Section 17.6.3.2.1, ACI 318-14 Section 17.4.3.2 or ACI 318-11 Section D.5.3.2, the nominal pullout strength in cracked concrete for anchors installed in the soffit of sand-lightweight or normal-weight concrete over steel deck floor and roof assemblies $N_{p,deck,cr}$ shall be substituted for $N_{p,cr}$. Where analysis indicates no cracking at service loads, the normal pullout strength in uncracked concrete $N_{p,deck,uncr}$ shall be substituted for $N_{p,uncr}$. For seismic loads, $N_{p,deck,eq}$ shall be substituted for N_p .
- In accordance with ACI 318-19 Section 17.7.1.2(c), ACI 318-14 Section 17.5.1.2(c) or ACI 318-11 Section D.6.1.2(c), the shear strength for anchors installed in the soffit of sand-lightweight or normal-weight concrete over steel deck floor and roof assemblies $V_{sa,deck}$ shall be substituted for V_{sa} . For seismic loads, $V_{sa,deck,eq}$ shall be substituted for V_{sa} .
- The minimum anchor spacing along the flute must be the greater of $3.0h_{ef}$ or 1.5 times the flute width.
- The characteristic pull-out strength for greater concrete compressive strengths shall be increased by multiplying the tabular value by $(f'_c / 3,000 \text{ psi})^{0.5}$.
- Concrete shall be normal-weight or structural sand-lightweight concrete having a minimum specified compressive strength, f'_c , of 3,000 psi.
- Minimum distance to edge of panel is $2h_{ef}$.

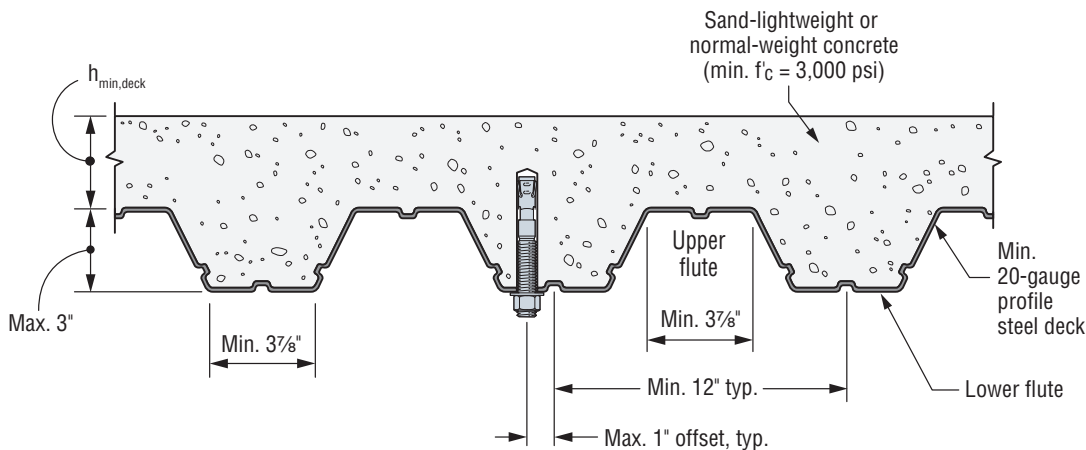
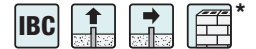

Figure 3

*See p. 14 for an explanation of the load table icons.

Strong-Bolt® 2 Design Information — Masonry

Zinc-Plated Carbon-Steel Strong-Bolt 2 Tension and Shear Loads in 8" Lightweight, Medium-Weight and Normal-Weight Grout-Filled CMU



| Size in. (mm) | Drill Bit Diameter (in.) | Min. Embed. Depth in. (mm) | Install. Torque ft.-lb. (N-m) | Critical Edge Dist. in. (mm) | Critical End Dist. in. (mm) | Critical Spacing in. (mm) | Tension Load | | Shear Load | |
|--|--------------------------|----------------------------|-------------------------------|------------------------------|-----------------------------|---------------------------|-------------------|--------------------|-------------------|--------------------|
| | | | | | | | Ultimate lb. (kN) | Allowable lb. (kN) | Ultimate lb. (kN) | Allowable lb. (kN) |
| Anchor Installed in the Face of the CMU Wall (See Figure 1) | | | | | | | | | | |
| 1/4 (6.4) | 1/4 | 1 3/4 (45) | 4 (5.4) | 12 (305) | 12 (305) | 8 (203) | 1,150 (5.1) | 230 (1.0) | 1,500 (6.7) | 300 (1.3) |
| 3/8 (9.5) | 3/8 | 2 5/8 (67) | 20 (27.1) | 12 (305) | 12 (305) | 8 (203) | 2,185 (9.7) | 435 (1.9) | 3,875 (17.2) | 775 (3.4) |
| 1/2 (12.7) | 1/2 | 3 1/2 (89) | 35 (47.5) | 12 (305) | 12 (305) | 8 (203) | 2,645 (11.8) | 530 (2.4) | 5,055 (22.5) | 1,010 (4.5) |
| 5/8 (15.9) | 5/8 | 4 3/8 (111) | 55 (74.6) | 20 (508) | 20 (508) | 8 (203) | 4,460 (19.8) | 890 (4.0) | 8,815 (39.2) | 1,765 (7.9) |
| 3/4 (19.1) | 3/4 | 5 1/4 (133) | 100 (135.6) | 20 (508) | 20 (508) | 8 (203) | 5,240 (23.3) | 1,050 (4.7) | 12,450 (55.4) | 2,490 (11.1) |

- The tabulated allowable loads are based on a safety factor of 5.0 for installation under the IBC and IRC.
- Listed loads may be applied to installations on the face of the CMU wall at least 1 1/4" away from head joints.
- Values for 8"-wide concrete masonry units (CMU) with a minimum specified compressive strength of masonry, f'_m , at 28 days is 1,500 psi.
- Embedment depth is measured from the outside face of the concrete masonry unit.
- Tension and shear loads may be combined using the parabolic interaction equation ($n = 5\%$).
- Refer to allowable load adjustment factors for edge distance and spacing on p. 106.

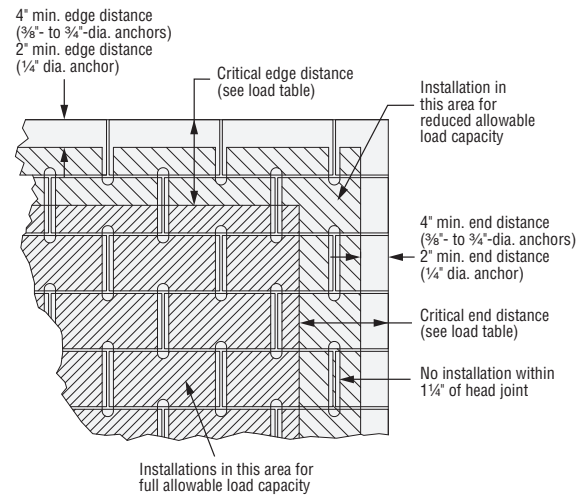

Figure 1

Zinc-Plated Carbon-Steel Strong-Bolt 2 Tension and Shear Loads in 8" Lightweight, Medium-Weight and Normal-Weight Grout-Filled CMU



| Size in. (mm) | Drill Bit Diameter in. | Min. Embed. Depth in. (mm) | Install. Torque ft.-lb. (N-m) | Min. Edge Dist. in. (mm) | Critical End Dist. in. (mm) | Critical Spacing in. (mm) | Tension Load | | Shear Load Perpendicular to Edge | | Shear Load Parallel to Edge | |
|---|------------------------|----------------------------|-------------------------------|--------------------------|-----------------------------|---------------------------|-------------------|--------------------|----------------------------------|--------------------|-----------------------------|--------------------|
| | | | | | | | Ultimate lb. (kN) | Allowable lb. (kN) | Ultimate lb. (kN) | Allowable lb. (kN) | Ultimate lb. (kN) | Allowable lb. (kN) |
| Anchor Installed in Cell Opening or Web (Top of Wall) (See Figure 2) | | | | | | | | | | | | |
| 1/2 (12.7) | 1/2 | 3 1/2 (89) | 35 (47.5) | 1 3/4 (45) | 12 (305) | 8 (203) | 2,080 (9.3) | 415 (1.8) | 1,165 (5.2) | 235 (1.0) | 3,360 (14.9) | 670 (3.0) |
| 5/8 (15.9) | 5/8 | 4 3/8 (111) | 55 (74.6) | 1 3/4 (45) | 12 (305) | 8 (203) | 3,200 (14.2) | 640 (2.8) | 1,370 (6.1) | 275 (1.2) | 3,845 (17.1) | 770 (3.4) |

- The tabulated allowable loads are based on a safety factor of 5.0 for installation under the IBC and IRC.
- Values for 8"-wide concrete masonry units (CMU) with a minimum specified compressive strength of masonry, f'_m , at 28 days is 1,500 psi.
- Tension and shear loads may be combined using the parabolic interaction equation ($n = 5\%$).
- Refer to allowable load adjustment factors for edge distance and spacing on p. 106.

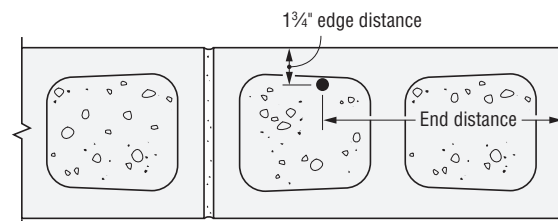

Figure 2

*See p. 14 for an explanation of the load table icons.

Strong-Bolt® 2 Design Information — Masonry

Zinc-Plated Carbon-Steel Strong-Bolt 2 Allowable Load Adjustment Factors for Face-of-Wall Installation in 8" Grout-Filled CMU: Edge Distance and Spacing, Tension and Shear Loads

How to use these charts:

- The following tables are for reduced edge distance and spacing.
- Locate the anchor size to be used for either a tension and/or shear load application.
- Locate the embedment (E) at which the anchor is to be installed.
- Locate the edge distance (c_{act}) or spacing (s_{act}) at which the anchor is to be installed.
- The load adjustment factor (f_c or f_s) is the intersection of the row and column.
- Multiply the allowable load by the applicable load adjustment factor.
- Reduction factors for multiple edges or spacings are multiplied together.

Edge or End Distance Tension (f_c)

| c_{act} (in.) | Dia. | 1/4 | 3/8 | 1/2 | 5/8 | 3/4 |
|--------------------|------------|-------|-------|-------|-------|-------|
| | E | 1 3/4 | 2 5/8 | 3 1/2 | 4 3/8 | 5 1/4 |
| | c_{cr} | 12 | 12 | 12 | 20 | 20 |
| | c_{min} | 2 | 4 | 4 | 4 | 4 |
| | f_{cmin} | 1.00 | 1.00 | 1.00 | 1.00 | 0.97 |
| 2 | | 1.00 | | | | |
| 4 | | 1.00 | 1.00 | 1.00 | 1.00 | 0.97 |
| 6 | | 1.00 | 1.00 | 1.00 | 1.00 | 0.97 |
| 8 | | 1.00 | 1.00 | 1.00 | 1.00 | 0.98 |
| 10 | | 1.00 | 1.00 | 1.00 | 1.00 | 0.98 |
| 12 | | 1.00 | 1.00 | 1.00 | 1.00 | 0.99 |
| 14 | | | | | 1.00 | 0.99 |
| 16 | | | | | 1.00 | 0.99 |
| 18 | | | | | 1.00 | 1.00 |
| 20 | | | | | 1.00 | 1.00 |

Edge or End Distance Shear (f_c)

| c_{act} (in.) | Dia. | 1/4 | 3/8 | 1/2 | 5/8 | 3/4 |
|--------------------|------------|-------|-------|-------|-------|-------|
| | E | 1 3/4 | 2 5/8 | 3 1/2 | 4 3/8 | 5 1/4 |
| | c_{cr} | 12 | 12 | 12 | 20 | 20 |
| | c_{min} | 2 | 4 | 4 | 4 | 4 |
| | f_{cmin} | 0.88 | 0.71 | 0.60 | 0.36 | 0.28 |
| 2 | | 0.88 | | | | |
| 4 | | 0.90 | 0.71 | 0.60 | 0.36 | 0.28 |
| 6 | | 0.93 | 0.78 | 0.70 | 0.44 | 0.37 |
| 8 | | 0.95 | 0.86 | 0.80 | 0.52 | 0.46 |
| 10 | | 0.98 | 0.93 | 0.90 | 0.60 | 0.55 |
| 12 | | 1.00 | 1.00 | 1.00 | 0.68 | 0.64 |
| 14 | | | | | 0.76 | 0.73 |
| 16 | | | | | 0.84 | 0.82 |
| 18 | | | | | 0.92 | 0.91 |
| 20 | | | | | 1.00 | 1.00 |

Spacing Tension (f_s)

| s_{act} (in.) | Dia. | 1/4 | 3/8 | 1/2 | 5/8 | 3/4 |
|--------------------|------------|-------|-------|-------|-------|-------|
| | E | 1 3/4 | 2 5/8 | 3 1/2 | 4 3/8 | 5 1/4 |
| | s_{cr} | 8 | 8 | 8 | 8 | 8 |
| | s_{min} | 4 | 4 | 4 | 4 | 4 |
| | f_{smin} | 1.00 | 1.00 | 0.93 | 0.86 | 0.80 |
| 4 | | 1.00 | 1.00 | 0.93 | 0.86 | 0.80 |
| 6 | | 1.00 | 1.00 | 0.97 | 0.93 | 0.90 |
| 8 | | 1.00 | 1.00 | 1.00 | 1.00 | 1.00 |

Spacing Shear (f_s)

| s_{act} (in.) | Dia. | 1/4 | 3/8 | 1/2 | 5/8 | 3/4 |
|--------------------|------------|-------|-------|-------|-------|-------|
| | E | 1 3/4 | 2 5/8 | 3 1/2 | 4 3/8 | 5 1/4 |
| | s_{cr} | 8 | 8 | 8 | 8 | 8 |
| | s_{min} | 4 | 4 | 4 | 4 | 4 |
| | f_{smin} | 1.00 | 1.00 | 1.00 | 1.00 | 1.00 |
| 4 | | 1.00 | 1.00 | 1.00 | 1.00 | 1.00 |
| 6 | | 1.00 | 1.00 | 1.00 | 1.00 | 1.00 |
| 8 | | 1.00 | 1.00 | 1.00 | 1.00 | 1.00 |

Load Adjustment Factors for Carbon-Steel Strong-Bolt 2 Wedge Anchors in Top-of-Wall Installation in 8" Grout-Filled CMU: Edge Distance and Spacing, Tension and Shear Loads

End Distance Tension (f_c)

| s_{act} (in.) | Dia. | 1/2 | 5/8 |
|--------------------|------------|-------|-------|
| | E | 3 1/2 | 4 3/8 |
| | c_{cr} | 12 | 12 |
| | c_{min} | 4 | 4 |
| | f_{cmin} | 1.00 | 1.00 |
| 4 | | 1.00 | 1.00 |
| 6 | | 1.00 | 1.00 |
| 8 | | 1.00 | 1.00 |
| 10 | | 1.00 | 1.00 |
| 12 | | 1.00 | 1.00 |

End Distance Shear Perpendicular to Edge (f_c)

| c_{act} (in.) | Dia. | 1/2 | 5/8 |
|--------------------|------------|-------|-------|
| | E | 3 1/2 | 4 3/8 |
| | c_{cr} | 12 | 12 |
| | c_{min} | 4 | 4 |
| | f_{cmin} | 0.90 | 0.83 |
| 4 | | 0.90 | 0.83 |
| 6 | | 0.93 | 0.87 |
| 8 | | 0.95 | 0.92 |
| 10 | | 0.98 | 0.96 |
| 12 | | 1.00 | 1.00 |

End Distance Shear Parallel to Edge (f_c)

| c_{act} (in.) | Dia. | 1/2 | 5/8 |
|--------------------|------------|-------|-------|
| | E | 3 1/2 | 4 3/8 |
| | c_{cr} | 12 | 12 |
| | c_{min} | 4 | 4 |
| | f_{cmin} | 0.53 | 0.50 |
| 4 | | 0.53 | 0.50 |
| 6 | | 0.65 | 0.63 |
| 8 | | 0.77 | 0.75 |
| 10 | | 0.88 | 0.88 |
| 12 | | 1.00 | 1.00 |

Spacing Tension (f_s)

| s_{act} (in.) | Dia. | 1/2 | 5/8 |
|--------------------|------------|-------|-------|
| | E | 3 1/2 | 4 3/8 |
| | s_{cr} | 8 | 8 |
| | s_{min} | 4 | 4 |
| | f_{smin} | 0.93 | 0.86 |
| 4 | | 0.93 | 0.86 |
| 6 | | 0.97 | 0.93 |
| 8 | | 1.00 | 1.00 |

Spacing Shear Perpendicular or Parallel to Edge (f_s)

| s_{act} (in.) | Dia. | 1/2 | 5/8 |
|--------------------|------------|-------|-------|
| | E | 3 1/2 | 4 3/8 |
| | s_{cr} | 8 | 8 |
| | s_{min} | 4 | 4 |
| | f_{smin} | 1.00 | 1.00 |
| 4 | | 1.00 | 1.00 |
| 6 | | 1.00 | 1.00 |
| 8 | | 1.00 | 1.00 |

For footnotes, please see p. 105.

*See p. 14 for an explanation of the load table icons.