

Proof Load Guidelines for Titen HD® Anchors

Titen HD anchors are installed into hardened concrete by drilling a hole and torquing the anchor in with a wrench. During torquing, the anchor's serrated teeth self-tap internal threads into the walls of the concrete hole. The interlock between the anchor's threads and the hole's internal threads provide the anchor's resistance to tension loads.

Some project specifications require that installed anchors are tension-tested to verify proper installation and capacity in project-specific base materials. Test labs and inspectors are quite familiar with the process for tension-testing wedge anchors and adhesive anchors. These types of anchors have exposed threaded ends and are coupled directly with a pulling rod during a field tension test. Titen HD anchors do not have an exposed threaded end, thus a pulling fixture must be used to overcome this difference. Two types of pulling fixtures can be employed:

- Unslotted Pulling Fixtures:** If the bottom plate of the pulling fixture is unslotted, the anchor must be completely extracted from the hole so it can be rethreaded through the pulling fixture into the base material. Rethreading the anchor into the same hole will not reduce the load capacity of the anchor if the original threads that were cut into the concrete by the anchor are followed. Thus, it is highly recommended that the anchor be restarted by hand until the head of the anchor makes contact with the pulling fixture. Starting the fastener by hand will prevent cross-threading and possible capacity reductions.
- Slotted Pulling Fixtures:** Use of a pulling fixture with a slotted bottom plate is ideal. This allows anchors to be tested more quickly since the Titen HD anchor need only be backed out enough to slide the pulling fixture plate under the head of the anchor. However, the pulling fixture's bottom plate must usually be thicker to provide sufficient strength during the test.

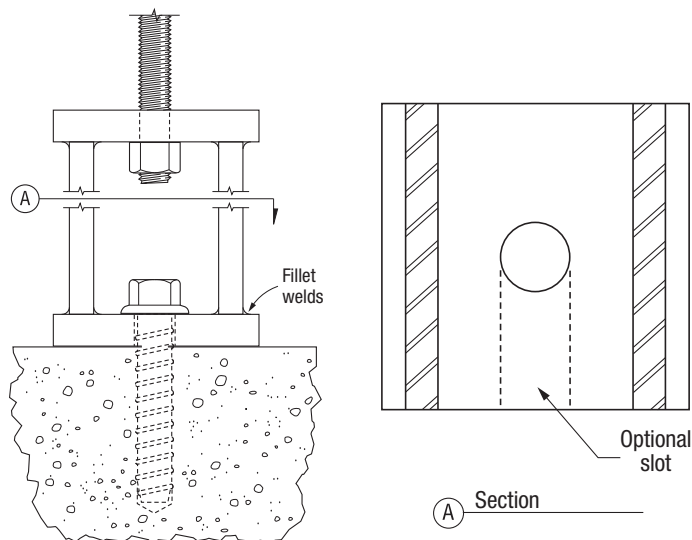

Note: Torque-testing of anchors is not considered to be a suitable method of verifying anchor tension capacity since the torque-to-tension relationship of concrete anchors varies depending on installation and base material conditions.

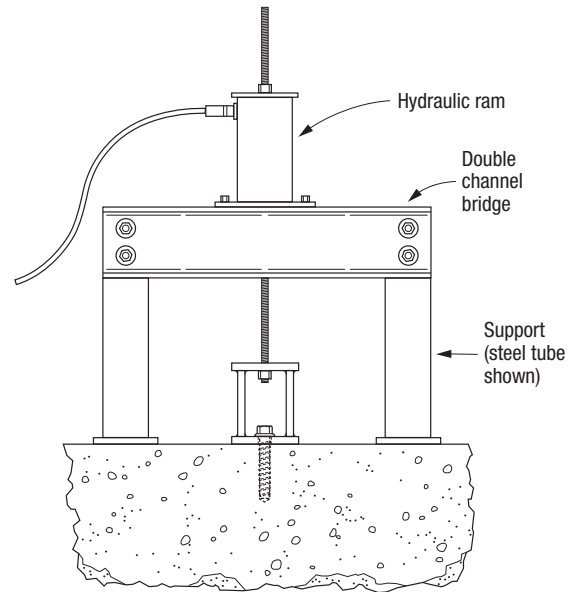

Regardless of which type of fixture is used, the engineer and inspector must pay special attention to the anchor's embedment depth during testing. For example, if one wishes to test a Titen HD anchor that is installed through a 2x4 wood plate that cannot be removed during testing, the anchor must be backed out enough to accommodate the thickness of the pulling fixture. This reduces the original embedment depth by the thickness of the pulling fixture and will reduce the capacity of the anchor in the as-tested condition when compared to the installed condition. The test load should be based on the anchor embedment depth in the as-tested condition.

Simpson Strong-Tie does not require proof loading of installed anchors. If required, the magnitude of the proof load is to be determined by the project Engineer of Record. The proof load should be large enough to establish confidence in the anchorage without inducing permanent deformation into the anchor or failing it. Proof load levels must not exceed 80% of the anchor's steel yield strength. Refer to code reports for the yield strengths of Titen HD anchor.