

QUALITY LIGHT STEEL FRAMING CONNECTIONS AND MEMBERS

LIGHT STEEL FRAMING MEMBERS

LOAD BEARING STUDS · X-BRACE SHEAR WALL · FLOOR JOIST SYSTEM

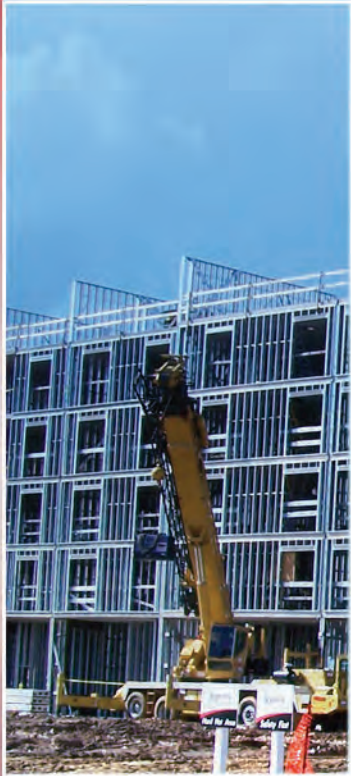

STEELNETWORK.COM
1.888.474.4876

About The Steel Network, Inc.:

The Steel Network, Inc. (TSN) provides solutions for all standard light steel framing applications, including load-bearing mid-rise construction systems, curtain wall systems, floor joist systems, rigid connectors, vertical deflection connectors, lateral drift connectors and anchorage connectors. Substantial effort has been made by the industry to standardize construction practices to ensure the positive connections of light steel framing components. Toward this end, all TSN products have undergone extensive field and laboratory testing to achieve complete solutions for both designers and installers. TSN's load bearing mid-rise construction system is widely used in commercial and government construction, such as hotels, dormitories and military barracks.

TSN's competitive advantage lies in the cost savings, rapid construction and green design/construction options provided by its core product lines, SigmaStud® and StiffWall® Load-bearing Shear Wall System, PrimeJoist®, JamStud®, BridgeClip®, VertiClip®, DriftClip®, PrimeWall® and Engineering Software.

Table of Contents

SigmaStud® Introduction.....	2
SigmaStud® Product Profile.....	3-4
SigmaStud® Section Properties.....	5-6
SigmaStud® Design Example.....	7
SigmaStud® Combined Axial & Lateral Load Tables.....	8-15
SigmaStud® STC Ratings and UL Assemblies.....	16
SigmaStud® Web Reinforcement.....	17
SigmaTrak® Introduction.....	18
SigmaTrak® Section Properties.....	19-20
Design Assist Services.....	21
Temporary Bracing.....	22
Construction Guide.....	23-24
Bridging Example Problem.....	25
Bridging Anchorage.....	26
StiffWall® Shear Wall System Introduction.....	27-28
StiffWall® SWS Design.....	29-30
Pre-Assembled Columns/Boots.....	31
StiffWall® Column Product Profile.....	32-35
StiffWall® Column Section Properties.....	36
StiffWall® Column Axial Load Tables.....	37-39
StiffWall® Boots.....	40-41
StiffWall® SWS Example Problem.....	42-44
Flat Strap.....	45
TightStrap® Strap Tensioner.....	46
Other Design Considerations for Shear Wall Systems.....	47
SWS Example Details.....	48
Floor Systems Introduction.....	49
PrimeJoist® Introduction.....	50
Floor System Fire & Sound Tested Assemblies.....	51
Floor System Design Considerations.....	52
PrimeJoist® Product Profile.....	53
PrimeJoist® Section Properties.....	54
Allowable Floor Joist Span Tables.....	55-61
Allowable Web Crippling.....	62-64
Floor Joist Framing Solutions.....	65
PrimeJoist® Example Details.....	66
SteelSmart® System Design Software.....	67

600SG250-43, 50ksi

Overall Depth
Ex: 6"

SG
SigmaStud® Section

Flange Width (in)
x 100
Ex: 2.5"

Material Thickness (mils)
Ex: 43mil (18ga)

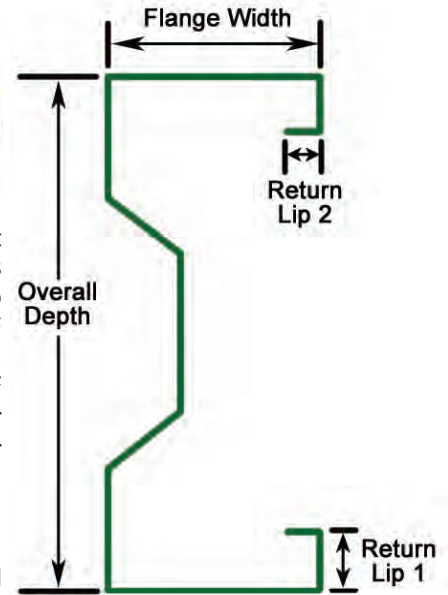

Background

SigmaStud® is a breakthrough in the load-bearing steel stud industry, producing significant increases in load capacity when compared with conventional “C” Shaped studs. SigmaStud’s unique configuration provides installation and design advantages which create efficiencies no other light steel framing (LSF) load bearing wall stud can provide. Each bend made to a flat LSF element increases load capacity over a standard stud section with the same material thickness. The return lips present in SigmaStud also increase capacity, delivering the most efficient LSF load-bearing stud member available. SigmaStud redefines previous limitations considered for utilization of steel studs in building construction, producing more cost-effective options for designing load bearing walls for clients. TSN’s 600SG™ and 800SG™ product lines are for 6” and 8” walls.

Material Properties:

ASTM A1003/A1003M or ASTM A653/A653M, Grade 50(340), 50ksi (340MPa) minimum yield strength, 65ksi (450 MPa) minimum tensile strength, G-60 (Z180) hot-dipped galvanized coating; or equivalent.

Benefits That Add Value:

Weight Advantages

- Lighter weight results in easier handling & shipping efficiencies
- Reduction of wall mass & labor costs
- 80% lighter than concrete/masonry block, optimizing foundation thickness

Fastener Efficiencies

- Screw size decreases with thinner material thickness of member material, facilitating faster connections
- Larger flange width increases area for fasteners

Performance Improvements

- Increased load capacity over similar standard “C-shaped” stud (14ga “C-shaped” to 18ga “SG” common)
- May eliminate double studs and their attachments to each other
- Compatible with all common types of floor systems and designs
- Accelerate construction schedules

Engineering Advantages

- Axial load capacity tables compatible with recent code changes

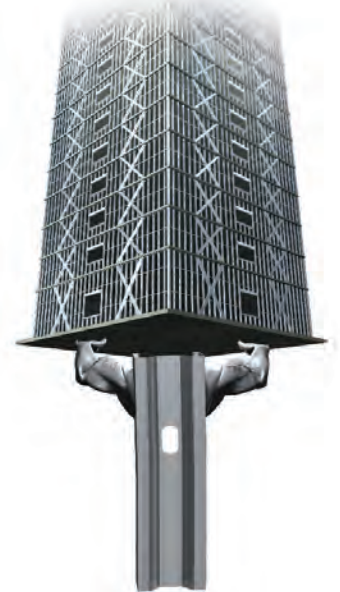

Design Comparison of SigmaStud® and Standard “C-Shape” Studs

Design Assumptions: Wall height: 9 feet; Bridging at 48" o.c. (vertically); Stud Spacing at 16" o.c.; Single or Back-to-Back Members Only; L/180 Deflection; F_y = 50 ksi for Both C-Shape and SigmaStud; 5 psf Lateral Load; No Load Reductions Taken.

Axial Load	“C” Shape, 1 5/8” Flange	“C” Shape, 2” Flange	SigmaStud® Section	Comparison Conclusion
↓				The data presents tangible examples of the exceptional value SigmaStud provides for designers, installers, and owners. In each case, SigmaStud represents a thinner and lighter option, resulting in significant material and labor efficiencies. As the axial load increases, the differences between a single member and 2 or even 3 “ganged” members become even more evident. The ganged members should be connected, either back-to-back or lip-to-lip. Back-to-back ganged studs are connected with either an engineered weld, flat strap and screws along the flanges, or screws through each web placed vertically at 24”o.c. (typical). Use of a single SigmaStud section eliminates the additional engineering as well as the installation of these elements. Contact TSN’s technical support team for design recommendations.
4k	600S162-54	600S200-43	600SG162-33	
8k	600S162-97	600S200-68	600SG200-43	
12k	(2) 600S162-54	600S200-97	600SG250-54	
16k	(2) 600S162-68	(2) 600S200-54	600SG250-68	
20k	(2) 600S162-97	(2) 600S200-68	600SG250-97	
24k	(2) 600S162-97	(2) 600S200-97	600SG250-97 or (2) 600SG250-54	
30k	(3) 600S162-97	(2) 600S200-97	600SG300-118 or (2) 600SG250-68	

Important Notes

1. Section properties and capacities are calculated in accordance with AISI S100-16 Specification.
2. Tabulated gross properties are based on the full-unreduced cross section of the studs, away from punchouts.
3. Effective section properties incorporate the strength increase from the cold-work of forming as applicable per AISI S100-16 Spec, Sec. A3.3.2 (3).
4. Net effective section properties are calculated at a cross section through the punchout.
5. Allowable moment is the lesser of M_{al} and M_{ad} . Stud distortional buckling is based on an assumed $k_{\phi} = 0$.
6. For deflection calculations, use the effective moment of inertia.
7. The effective moment of inertia for deflection is calculated at a stress which results in a section modulus such that the stress times the section modulus at that stress is equal to the allowable moment. AISI S100-16 Specification Procedure I for serviceability determination has been used.

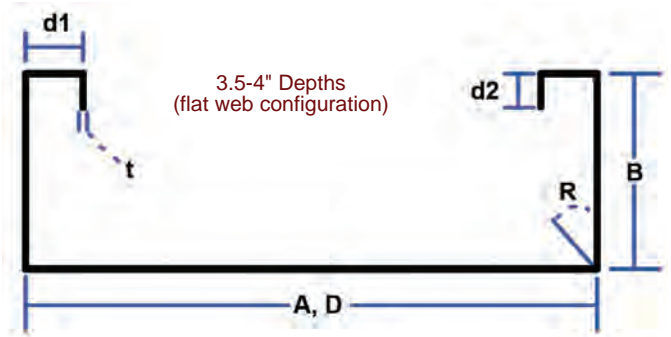

SigmaStud® Product Profile: 3.5" - 4" Stud Depths											
Section (All 50 ksi)	Overall Depth	Flange Width	Web Flat	Web Return	Web Return	Web Inside	Return Lip 1	Return Lip 2	Inside Bend Radius	Design Thickness	Unit Weight
	D	B	A	C	E	N	d1	d2	R	t	
	(in)	(in)	(in)	(in)	(in)	(in)	(in)	(in)	(in)	(in)	(lb/ft)
350SG200-33	3.5	2	3.5	N/A	N/A	N/A	0.5892	0.5	0.105	0.0346	1.078
350SG200-43	3.5	2	3.5	N/A	N/A	N/A	0.6102	0.5	0.105	0.0451	1.400
350SG200-54	3.5	2	3.5	N/A	N/A	N/A	0.6332	0.5	0.105	0.0566	1.749
350SG200-68	3.5	2	3.5	N/A	N/A	N/A	0.6626	0.5	0.105	0.0713	2.192
350SG200-97	3.5	2	3.5	N/A	N/A	N/A	0.7234	0.5	0.105	0.1017	3.092
350SG250-33	3.5	2.5	3.5	N/A	N/A	N/A	0.5892	0.5	0.105	0.0346	1.196
350SG250-43	3.5	2.5	3.5	N/A	N/A	N/A	0.6102	0.5	0.105	0.0451	1.553
350SG250-54	3.5	2.5	3.5	N/A	N/A	N/A	0.6332	0.5	0.105	0.0566	1.942
350SG250-68	3.5	2.5	3.5	N/A	N/A	N/A	0.6626	0.5	0.105	0.0713	2.435
350SG250-97	3.5	2.5	3.5	N/A	N/A	N/A	0.7234	0.5	0.105	0.1017	3.438
350SG350-68	3.5	3.5	3.5	N/A	N/A	N/A	0.6626	0.5	0.105	0.0713	2.920
362SG200-33	3.625	2	3.625	N/A	N/A	N/A	0.5892	0.5	0.105	0.0346	1.093
362SG200-43	3.625	2	3.625	N/A	N/A	N/A	0.6102	0.5	0.105	0.0451	1.419
362SG200-54	3.625	2	3.625	N/A	N/A	N/A	0.6332	0.5	0.105	0.0566	1.773
362SG200-68	3.625	2	3.625	N/A	N/A	N/A	0.6626	0.5	0.105	0.0713	2.222
362SG200-97	3.625	2	3.625	N/A	N/A	N/A	0.7234	0.5	0.105	0.1017	3.135
362SG250-33	3.625	2.5	3.625	N/A	N/A	N/A	0.5892	0.5	0.105	0.0346	1.210
362SG250-43	3.625	2.5	3.625	N/A	N/A	N/A	0.6102	0.5	0.105	0.0451	1.572
362SG250-54	3.625	2.5	3.625	N/A	N/A	N/A	0.6332	0.5	0.105	0.0566	1.966
362SG250-68	3.625	2.5	3.625	N/A	N/A	N/A	0.6626	0.5	0.105	0.0713	2.465
362SG250-97	3.625	2.5	3.625	N/A	N/A	N/A	0.7234	0.5	0.105	0.1017	3.481
362SG350-68	3.625	3.5	3.625	N/A	N/A	N/A	0.6626	0.5	0.105	0.0713	2.950
400SG200-33	4	2	4	N/A	N/A	N/A	0.5892	0.5	0.105	0.0346	1.137
400SG200-43	4	2	4	N/A	N/A	N/A	0.6102	0.5	0.105	0.0451	1.477
400SG200-54	4	2	4	N/A	N/A	N/A	0.6332	0.5	0.105	0.0566	1.846
400SG200-68	4	2	4	N/A	N/A	N/A	0.6626	0.5	0.105	0.0713	2.313
400SG200-97	4	2	4	N/A	N/A	N/A	0.7234	0.5	0.105	0.1017	3.265
400SG250-33	4	2.5	4	N/A	N/A	N/A	0.5892	0.5	0.105	0.0346	1.255
400SG250-43	4	2.5	4	N/A	N/A	N/A	0.6102	0.5	0.105	0.0451	1.630
400SG250-54	4	2.5	4	N/A	N/A	N/A	0.6332	0.5	0.105	0.0566	2.038
400SG250-68	4	2.5	4	N/A	N/A	N/A	0.6626	0.5	0.105	0.0713	2.556
400SG250-97	4	2.5	4	N/A	N/A	N/A	0.7234	0.5	0.105	0.1017	3.611
400SG350-68	4	3.5	4	N/A	N/A	N/A	0.6626	0.5	0.105	0.0713	3.041
400SG350-97	4	3.5	4	N/A	N/A	N/A	0.7234	0.5	0.105	0.1017	4.303
400SG350-118	4	3.5	4	N/A	N/A	N/A	0.7684	0.5	0.105	0.1242	5.216

Load Bearing Wall Members

SigmaStud® Product Profile

Important Notes

1. Section properties and capacities are calculated in accordance with AISI S100-16 Specification.
2. Tabulated gross properties are based on the full-unreduced cross section of the studs, away from punchouts.
3. Effective section properties incorporate the strength increase from the cold-work of forming as applicable per AISI S100-16 Spec, Sec. A3.3.2 (3).
4. Net effective section properties are calculated at a cross section through the punchout.
5. Allowable moment is the lesser of M_{al} and M_{ad} . Stud distortional buckling is based on an assumed $k_{\phi} = 0$.
6. For deflection calculations, use the effective moment of inertia.
7. The effective moment of inertia for deflection is calculated at a stress which results in a section modulus such that the stress times the section modulus at that stress is equal to the allowable moment. AISI S100-16 Specification Procedure I for serviceability determination has been used.

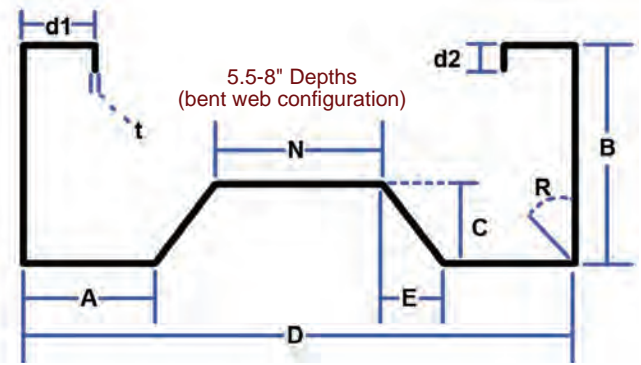

SigmaStud® Product Profile: 5.5" - 8" Stud Depths 5.5" - 8"											
Section (All 50 ksi)	Overall Depth	Flange Width	Web Flat	Web Return	Web Return	Web Inside	Return Lip 1	Return Lip 2	Inside Bend Radius	Design Thickness	Unit Weight
	D (in)	B (in)	A (in)	C (in)	E (in)	N (in)	d1 (in)	d2 (in)	R (in)	t (in)	(lb/ft)
550SG162-33	5.5	1.625	1	1	0.625	2.25	0.5	0	0.105	0.0346	1.232
550SG162-43	5.5	1.625	1	1	0.625	2.25	0.5	0	0.105	0.0451	1.598
550SG200-33	5.5	2	1	1	0.625	2.25	0.5892	0.5	0.105	0.0346	1.438
550SG200-43	5.5	2	1	1	0.625	2.25	0.6102	0.5	0.105	0.0451	1.869
550SG200-54	5.5	2	1	1	0.625	2.25	0.6332	0.5	0.105	0.0566	2.338
550SG200-68	5.5	2	1	1	0.625	2.25	0.6626	0.5	0.105	0.0713	2.933
550SG200-97	5.5	2	1	1	0.625	2.25	0.7234	0.5	0.105	0.1017	4.147
550SG250-33	5.5	2.5	1	1	0.625	2.25	0.5892	0.5	0.105	0.0346	1.556
550SG250-43	5.5	2.5	1	1	0.625	2.25	0.6102	0.5	0.105	0.0451	2.023
550SG250-54	5.5	2.5	1	1	0.625	2.25	0.6332	0.5	0.105	0.0566	2.531
550SG250-68	5.5	2.5	1	1	0.625	2.25	0.6626	0.5	0.105	0.0713	3.176
550SG250-97	5.5	2.5	1	1	0.625	2.25	0.7234	0.5	0.105	0.1017	4.493
550SG300-43	5.5	3	1	1	0.625	2.25	0.6102	0.5	0.105	0.0451	2.176
550SG300-54	5.5	3	1	1	0.625	2.25	0.6332	0.5	0.105	0.0566	2.723
550SG300-68	5.5	3	1	1	0.625	2.25	0.6626	0.5	0.105	0.0713	3.418
550SG300-97	5.5	3	1	1	0.625	2.25	0.7234	0.5	0.105	0.1017	4.839
550SG300-118	5.5	3	1	1	0.625	2.25	0.7684	0.5	0.105	0.1242	5.867
600SG162-33	6	1.625	1.25	1	0.625	2.25	0.5	0	0.105	0.0346	1.291
600SG162-43	6	1.625	1.25	1	0.625	2.25	0.5	0	0.105	0.0451	1.674
600SG200-33	6	2	1.25	1	0.625	2.25	0.5892	0.5	0.105	0.0346	1.497
600SG200-43	6	2	1.25	1	0.625	2.25	0.6102	0.5	0.105	0.0451	1.946
600SG200-54	6	2	1.25	1	0.625	2.25	0.6332	0.5	0.105	0.0566	2.435
600SG200-68	6	2	1.25	1	0.625	2.25	0.6626	0.5	0.105	0.0713	3.054
600SG200-97	6	2	1.25	1	0.625	2.25	0.7234	0.5	0.105	0.1017	4.320
600SG250-33	6	2.5	1.25	1	0.625	2.25	0.5892	0.5	0.105	0.0346	1.615
600SG250-43	6	2.5	1.25	1	0.625	2.25	0.6102	0.5	0.105	0.0451	2.100
600SG250-54	6	2.5	1.25	1	0.625	2.25	0.6332	0.5	0.105	0.0566	2.627
600SG250-68	6	2.5	1.25	1	0.625	2.25	0.6626	0.5	0.105	0.0713	3.297
600SG250-97	6	2.5	1.25	1	0.625	2.25	0.7234	0.5	0.105	0.1017	4.666
600SG300-43	6	3	1.25	1	0.625	2.25	0.6102	0.5	0.105	0.0451	2.253
600SG300-54	6	3	1.25	1	0.625	2.25	0.6332	0.5	0.105	0.0566	2.820
600SG300-68	6	3	1.25	1	0.625	2.25	0.6626	0.5	0.105	0.0713	3.540
600SG300-97	6	3	1.25	1	0.625	2.25	0.7234	0.5	0.105	0.1017	5.012
600SG300-118	6	3	1.25	1	0.625	2.25	0.7684	0.5	0.105	0.1242	6.078
800SG162-33	8	1.625	2.25	1	0.625	2.25	0.5	0	0.105	0.0346	1.526
800SG162-43	8	1.625	2.25	1	0.625	2.25	0.5	0	0.105	0.0451	1.981
800SG200-33	8	2	2.25	1	0.625	2.25	0.5892	0.5	0.105	0.0346	1.733
800SG200-43	8	2	2.25	1	0.625	2.25	0.6102	0.5	0.105	0.0451	2.253
800SG200-54	8	2	2.25	1	0.625	2.25	0.6332	0.5	0.105	0.0566	2.820
800SG200-68	8	2	2.25	1	0.625	2.25	0.6626	0.5	0.105	0.0713	3.540
800SG200-97	8	2	2.25	1	0.625	2.25	0.7234	0.5	0.105	0.1017	5.012
800SG250-33	8	2.5	2.25	1	0.625	2.25	0.5892	0.5	0.105	0.0346	1.851
800SG250-43	8	2.5	2.25	1	0.625	2.25	0.6102	0.5	0.105	0.0451	2.406
800SG250-54	8	2.5	2.25	1	0.625	2.25	0.6332	0.5	0.105	0.0566	3.012
800SG250-68	8	2.5	2.25	1	0.625	2.25	0.6626	0.5	0.105	0.0713	3.782
800SG250-97	8	2.5	2.25	1	0.625	2.25	0.7234	0.5	0.105	0.1017	5.358
800SG300-43	8	3	2.25	1	0.625	2.25	0.6102	0.5	0.105	0.0451	2.560
800SG300-54	8	3	2.25	1	0.625	2.25	0.6332	0.5	0.105	0.0566	3.205
800SG300-68	8	3	2.25	1	0.625	2.25	0.6626	0.5	0.105	0.0713	4.025
800SG300-97	8	3	2.25	1	0.625	2.25	0.7234	0.5	0.105	0.1017	5.704
800SG300-118	8	3	2.25	1	0.625	2.25	0.7684	0.5	0.105	0.1242	6.922

Important Notes

1. Section properties and capacities are calculated in accordance with AISI S100-16 Spec, "North American Specification for the Design of Cold-Formed Steel Structural Members".
2. Tabulated gross properties are based on the full-unreduced cross section of the studs, away from punchouts.
3. Effective section properties incorporate the strength increase from the cold-work of forming as applicable per AISI S100-16 Spec, Sec. A3.3.2 (3).
4. Allowable moment is the lesser of M_{al} and M_{ad} . Stud distortional buckling is based on an assumed $k_{\phi} = 0$.
5. For deflection calculations, use the effective moment of inertia.
6. The effective moment of inertia for deflection is calculated at a stress which results in a section modulus such that the stress times the section modulus at that stress is equal to the allowable moment. AISI S100-16 Procedure I for serviceability determination has been used.

SigmaStud® Section Properties																						
Section (All 50 ksi)	Gross Properties						Torsional Properties						Effective Properties 50 ksi									
	Area	I_x	S_x	R_x	I_y	R_y	$Jx10$	C_w	X_o	m	X_o	β	$A_{e(net)}$	I_{xe}	S_{xe}	$S_{xs(net)}$	M_{al}	$M_{al(net)}$	M_{ad}	$M_{ad(net)}$	V_a	$V_{a(net)}$
	(in ²)	(in ⁴)	(in ³)	(in)	(in ⁴)	(in)	(in ⁶)	(in ⁶)	(in)	(in)	(in)		(in ²)	(in ⁴)	(in ³)	(in ³)	(in-k)	(in-k)	(in-k)	(in-k)	(lbs)	(lbs)
350SG200-33	0.317	0.630	0.360	1.410	0.194	0.782	0.126	0.718	-1.975	1.178	2.549	0.400	0.201	0.615	0.310	0.283	9.295	8.479	8.570	8.332	1144	527
350SG200-43	0.411	0.810	0.463	1.404	0.249	0.779	0.279	0.929	-1.969	1.176	2.541	0.399	0.293	0.810	0.430	0.406	12.878	12.161	12.176	11.825	2141	747
350SG200-54	0.514	1.003	0.573	1.397	0.309	0.775	0.549	1.158	-1.963	1.173	2.531	0.398	0.384	1.003	0.550	0.530	16.470	15.871	16.295	15.825	3371	925
350SG200-68	0.644	1.241	0.709	1.388	0.382	0.770	1.091	1.444	-1.955	1.169	2.519	0.397	0.529	1.241	0.709	0.696	23.531	20.831	23.373	20.636	4208	900
350SG200-97	0.909	1.705	0.974	1.370	0.525	0.760	3.132	2.017	-1.938	1.160	2.492	0.395	0.756	1.705	0.974	0.958	33.387	32.831	33.387	32.827	5886	850
350SG250-33	0.351	0.734	0.419	1.445	0.329	0.967	0.140	1.206	-2.476	1.448	3.025	0.330	0.210	0.693	0.331	0.300	9.904	8.995	9.106	8.870	1144	527
350SG250-43	0.456	0.945	0.540	1.439	0.424	0.964	0.309	1.565	-2.471	1.445	3.017	0.329	0.292	0.933	0.447	0.418	13.371	12.505	13.045	12.687	2141	747
350SG250-54	0.571	1.171	0.669	1.432	0.526	0.960	0.609	1.953	-2.465	1.442	3.008	0.329	0.383	1.171	0.571	0.545	17.099	16.324	17.616	17.120	3371	925
350SG250-68	0.715	1.450	0.829	1.424	0.653	0.955	1.212	2.443	-2.457	1.439	2.996	0.328	0.519	1.450	0.748	0.728	22.400	21.809	23.676	23.014	4208	900
350SG250-97	1.010	1.999	1.142	1.406	0.904	0.946	3.483	3.431	-2.441	1.430	2.972	0.325	0.835	1.999	1.125	1.107	37.597	37.006	38.177	37.438	5886	850
350SG350-68	0.858	1.870	1.068	1.476	1.471	1.309	1.454	5.401	-3.456	1.965	3.980	0.246	0.535	1.812	0.804	0.774	24.073	23.179	26.651	25.932	4208	900
362SG200-33	0.321	0.683	0.377	1.459	0.196	0.782	0.128	0.759	-1.954	1.168	2.561	0.418	0.202	0.668	0.326	0.295	9.754	8.842	8.919	8.673	1102	544
362SG200-43	0.417	0.879	0.485	1.452	0.253	0.779	0.283	0.983	-1.948	1.166	2.552	0.417	0.293	0.879	0.451	0.424	13.504	12.690	12.685	12.320	2141	802
362SG200-54	0.521	1.089	0.601	1.445	0.313	0.775	0.556	1.224	-1.942	1.163	2.542	0.416	0.385	1.089	0.577	0.553	17.261	16.571	16.994	16.504	3372	994
362SG200-68	0.653	1.348	0.744	1.437	0.388	0.770	1.107	1.526	-1.934	1.159	2.530	0.415	0.532	1.348	0.744	0.728	24.678	21.799	24.401	21.653	4375	1007
362SG200-97	0.921	1.854	1.023	1.419	0.533	0.761	3.176	2.130	-1.918	1.150	2.504	0.413	0.769	1.854	1.023	1.007	35.050	34.514	35.050	34.509	6124	954
362SG250-33	0.356	0.795	0.438	1.495	0.333	0.968	0.142	1.277	-2.453	1.437	3.031	0.345	0.210	0.751	0.347	0.313	10.387	9.375	9.461	9.217	1102	544
362SG250-43	0.462	1.024	0.565	1.489	0.430	0.964	0.313	1.656	-2.447	1.435	3.023	0.344	0.293	1.011	0.468	0.435	14.012	13.038	13.565	13.194	2141	802
362SG250-54	0.578	1.269	0.700	1.482	0.533	0.961	0.617	2.066	-2.442	1.432	3.014	0.344	0.385	1.269	0.598	0.569	17.908	17.031	18.335	17.821	3372	994
362SG250-68	0.724	1.573	0.868	1.474	0.662	0.956	1.227	2.583	-2.434	1.428	3.002	0.342	0.522	1.573	0.783	0.761	23.449	22.775	24.670	23.982	4375	1007
362SG250-97	1.023	2.169	1.197	1.456	0.916	0.946	3.527	3.625	-2.418	1.420	2.977	0.340	0.848	2.169	1.178	1.161	39.389	38.814	40.011	39.252	6124	954
362SG350-68	0.867	2.023	1.116	1.528	1.491	1.311	1.469	5.715	-3.430	1.954	3.977	0.256	0.538	1.961	0.841	0.808	25.186	24.190	27.689	26.946	4375	1007
400SG200-33	0.334	0.859	0.429	1.603	0.204	0.782	0.133	0.895	-1.894	1.139	2.602	0.470	0.202	0.842	0.373	0.332	11.168	9.928	9.971	9.701	991	589
400SG200-43	0.434	1.107	0.553	1.597	0.263	0.778	0.294	1.157	-1.889	1.136	2.593	0.469	0.295	1.107	0.515	0.477	15.429	14.276	14.220	13.817	2141	967
400SG200-54	0.542	1.371	0.686	1.590	0.325	0.775	0.579	1.440	-1.883	1.133	2.583	0.469	0.389	1.371	0.658	0.624	19.693	18.673	19.109	18.563	3372	1201
400SG200-68	0.680	1.700	0.850	1.581	0.403	0.770	1.152	1.794	-1.875	1.129	2.571	0.468	0.540	1.700	0.850	0.825	28.202	24.708	27.517	24.756	4876	1360
400SG200-97	0.959	2.344	1.172	1.563	0.555	0.760	3.308	2.498	-1.858	1.121	2.544	0.467	0.806	2.344	1.172	1.158	40.162	34.664	40.162	34.659	6839	1299
400SG250-33	0.369	0.995	0.497	1.643	0.346	0.969	0.147	1.506	-2.386	1.407	3.055	0.390	0.211	0.944	0.397	0.351	11.873	10.514	10.530	10.264	991	589
400SG250-43	0.479	1.283	0.641	1.637	0.446	0.965	0.325	1.951	-2.381	1.404	3.046	0.389	0.294	1.268	0.534	0.489	15.981	14.635	15.133	14.726	2141	967
400SG250-54	0.599	1.591	0.796	1.630	0.554	0.962	0.640	2.432	-2.375	1.401	3.037	0.388	0.388	1.591	0.681	0.640	20.397	19.150	20.506	19.938	3372	1201
400SG250-68	0.751	1.975	0.987	1.622	0.688	0.957	1.273	3.038	-2.368	1.398	3.025	0.387	0.530	1.975	0.891	0.858	26.669	25.675	27.679	26.913	4876	1360
400SG250-97	1.061	2.730	1.365	1.604	0.953	0.948	3.658	4.255	-2.352	1.390	3.000	0.386	0.908	2.730	1.343	1.351	44.884	40.448	45.635	40.443	6839	1299
400SG350-68	0.894	2.525	1.263	1.681	1.547	1.316	1.514	6.736	-3.354	1.922	3.976	0.288	0.545	2.447	0.955	0.909	28.602	27.223	30.818	30.002	4876	1360
400SG350-97	1.265	3.503	1.751	1.664	2.158	1.306	4.360	9.488	-3.339	1.915	3.953	0.286	0.917	3.483	1.502	1.473	44.961	44.092	49.104	47.809	6839	1299
400SG350-118	1.533	4.184	2.092	1.652	2.587	1.299	7.855	11.458	-3.328	1.909	3.936	0.285	1.235	4.184	1.980	1.955	59.268	58.533	62.640	61.275	8235	1256

Refer to Important Table Notes on Page 5

SigmaStud® Section Properties																						
Section (All 50 ksi)	Gross Properties						Torsional Properties						Effective Properties 50 ksi									
	Area	I _x	S _x	R _x	I _y	R _y	Jx10 ⁶	C _w	X _o	m	X _o	β	A _{e (net)}	I _{xe}	S _{xe}	S _{xe (net)}	M _{al}	M _{al (net)}	M _{ed}	M _{ed (net)}	V _a	V _{a (net)}
	(in ²)	(in ⁴)	(in ³)	(in)	(in ⁴)	(in)	(in ⁶)	(in ⁶)	(in)	(in)	(in)		(in ²)	(in ⁴)	(in ³)	(in ³)	(in-k)	(in-k)	(in-k)	(in-k)	(lbs)	(lbs)
550SG162-33	0.362	1.522	0.554	2.051	0.096	0.514	0.144	0.864	-0.203	0.495	2.124	0.991	0.261	1.522	0.498	0.492	14.920	14.716	11.731	11.263	996	586
550SG162-43	0.469	1.963	0.714	2.045	0.122	0.510	0.318	1.097	-0.191	0.504	2.116	0.992	0.364	1.963	0.663	0.655	19.843	19.611	16.926	16.198	2141	953
550SG200-33	0.423	1.882	0.684	2.110	0.175	0.643	0.169	1.783	-0.716	0.160	2.319	0.905	0.315	1.858	0.609	0.602	18.234	18.016	14.840	14.464	996	586
550SG200-43	0.549	2.432	0.884	2.104	0.225	0.640	0.372	2.294	-0.708	0.165	2.310	0.906	0.447	2.432	0.833	0.826	24.934	24.718	21.359	20.787	2141	953
550SG200-54	0.687	3.023	1.099	2.097	0.278	0.636	0.734	2.838	-0.700	0.172	2.301	0.907	0.577	3.023	1.058	1.050	31.665	31.425	28.982	28.186	3372	1176
550SG200-68	0.862	3.761	1.368	2.089	0.344	0.631	1.460	3.510	-0.689	0.180	2.289	0.909	0.755	3.761	1.368	1.361	45.387	45.149	42.130	40.928	4793	1298
550SG200-97	1.219	5.229	1.901	2.072	0.471	0.622	4.201	4.816	-0.667	0.197	2.263	0.913	1.066	5.229	1.901	1.891	65.164	64.815	65.164	64.762	6657	1207
550SG250-33	0.457	2.140	0.778	2.163	0.302	0.813	0.182	2.936	-1.157	0.109	2.584	0.800	0.324	2.055	0.644	0.634	19.272	18.975	15.414	15.050	996	586
550SG250-43	0.594	2.767	1.006	2.158	0.389	0.809	0.403	3.788	-1.149	0.104	2.575	0.801	0.446	2.750	0.860	0.848	25.735	25.384	22.319	21.755	2141	953
550SG250-54	0.744	3.442	1.252	2.151	0.483	0.806	0.794	4.701	-1.141	0.098	2.565	0.802	0.576	3.442	1.092	1.078	32.686	32.274	30.488	29.686	3372	1176
550SG250-68	0.933	4.286	1.559	2.143	0.599	0.801	1.581	5.835	-1.131	0.090	2.552	0.804	0.745	4.286	1.418	1.403	42.443	42.007	41.569	40.458	4793	1298
550SG250-97	1.320	5.970	2.171	2.126	0.826	0.791	4.552	8.069	-1.108	0.073	2.525	0.807	1.143	5.970	2.133	2.121	71.321	70.907	71.151	69.241	6657	1207
550SG300-43	0.639	3.103	1.128	2.203	0.622	0.987	0.434	5.742	-1.597	0.369	2.894	0.695	0.443	2.993	0.876	0.859	26.214	25.729	23.034	22.484	2141	953
550SG300-54	0.800	3.861	1.404	2.197	0.773	0.983	0.855	7.139	-1.589	0.363	2.884	0.696	0.580	3.736	1.128	1.110	33.781	33.222	31.625	30.830	3372	1176
550SG300-68	1.004	4.812	1.750	2.189	0.960	0.978	1.702	8.883	-1.579	0.355	2.870	0.697	0.756	4.765	1.476	1.455	44.180	43.572	43.406	42.278	4793	1298
550SG300-97	1.422	6.711	2.440	2.172	1.332	0.968	4.902	12.348	-1.557	0.340	2.843	0.700	1.187	6.711	2.310	2.293	69.159	68.650	69.483	67.704	6657	1207
550SG300-118	1.724	8.048	2.927	2.161	1.590	0.960	8.837	14.766	-1.541	0.328	2.822	0.702	1.462	8.048	2.812	2.793	93.863	93.245	96.698	94.218	7956	1142
600SG162-33	0.379	1.854	0.618	2.211	0.104	0.523	0.151	1.090	-0.234	0.432	2.284	0.990	0.279	1.854	0.558	0.551	16.702	16.505	12.720	12.230	878	634
600SG162-43	0.492	2.392	0.797	2.205	0.133	0.519	0.334	1.386	-0.222	0.441	2.276	0.990	0.386	2.392	0.741	0.734	22.192	21.969	18.413	17.644	1959	1073
600SG200-33	0.440	2.291	0.764	2.282	0.187	0.653	0.176	2.203	-0.744	0.097	2.487	0.910	0.333	2.266	0.682	0.675	20.417	20.203	16.201	15.800	878	634
600SG200-43	0.572	2.962	0.987	2.276	0.241	0.650	0.388	2.837	-0.737	0.102	2.479	0.912	0.470	2.962	0.931	0.924	27.880	27.673	23.374	22.760	1959	1073
600SG200-54	0.715	3.683	1.228	2.269	0.299	0.646	0.764	3.513	-0.729	0.108	2.469	0.913	0.605	3.683	1.182	1.174	35.379	35.150	31.797	30.937	3372	1452
600SG200-68	0.898	4.586	1.529	2.261	0.370	0.642	1.521	4.350	-0.719	0.116	2.457	0.914	0.791	4.586	1.529	1.522	50.735	50.518	46.332	45.025	5352	1797
600SG200-97	1.269	6.386	2.129	2.243	0.508	0.633	4.376	5.980	-0.697	0.133	2.432	0.918	1.117	6.386	2.129	2.119	72.948	72.629	72.948	72.305	7610	1726
600SG250-33	0.475	2.599	0.866	2.340	0.320	0.822	0.189	3.590	-1.180	0.170	2.747	0.815	0.341	2.501	0.720	0.710	21.563	21.269	16.810	16.422	878	634
600SG250-43	0.617	3.362	1.121	2.334	0.413	0.818	0.418	4.633	-1.173	0.165	2.737	0.816	0.469	3.345	0.961	0.949	28.760	28.412	24.389	23.785	1959	1073
600SG250-54	0.772	4.183	1.394	2.328	0.513	0.815	0.824	5.752	-1.165	0.160	2.728	0.818	0.604	4.183	1.219	1.206	36.501	36.093	33.384	32.520	3372	1452
600SG250-68	0.969	5.213	1.738	2.320	0.636	0.810	1.642	7.145	-1.155	0.152	2.715	0.819	0.780	5.213	1.582	1.567	47.351	46.922	45.633	44.428	5352	1797
600SG250-97	1.371	7.270	2.423	2.303	0.879	0.800	4.727	9.893	-1.133	0.137	2.688	0.822	1.195	7.270	2.381	2.369	79.592	79.202	78.437	76.343	7610	1726
600SG300-43	0.662	3.761	1.254	2.384	0.655	0.995	0.449	6.972	-1.616	0.429	3.047	0.719	0.466	3.639	0.979	0.962	29.297	28.809	25.131	24.543	1959	1073
600SG300-54	0.829	4.683	1.561	2.377	0.814	0.991	0.885	8.670	-1.608	0.424	3.036	0.720	0.608	4.539	1.260	1.241	37.713	37.153	34.564	33.711	3372	1452
600SG300-68	1.040	5.840	1.947	2.369	1.012	0.986	1.763	10.793	-1.598	0.417	3.023	0.721	0.791	5.790	1.646	1.625	49.272	48.663	47.543	46.327	5352	1797
600SG300-97	1.473	8.155	2.718	2.353	1.404	0.976	5.078	15.015	-1.577	0.402	2.996	0.723	1.238	8.155	2.572	2.556	77.021	76.525	76.434	74.491	7610	1726
600SG300-118	1.786	9.789	3.263	2.341	1.678	0.969	9.154	17.967	-1.562	0.391	2.976	0.725	1.525	9.789	3.134	3.116	104.620	104.024	106.616	103.892	9118	1649
800SG162-33	0.448	3.631	0.908	2.845	0.130	0.538	0.179	2.193	-0.302	0.261	2.912	0.989	0.298	3.631	0.754	0.744	22.576	22.270	16.445	15.895	595	595
800SG162-43	0.582	4.691	1.173	2.839	0.166	0.534	0.395	2.796	-0.292	0.269	2.903	0.990	0.439	4.691	1.056	1.047	31.604	31.335	24.107	23.217	1324	1268
800SG200-33	0.509	4.453	1.113	2.957	0.230	0.672	0.203	4.278	-0.791	0.064	3.134	0.936	0.352	4.431	0.930	0.919	27.843	27.525	21.591	21.107	595	595
800SG200-43	0.662	5.765	1.441	2.951	0.296	0.669	0.449	5.516	-0.784	0.059	3.126	0.937	0.522	5.765	1.325	1.317	39.673	39.425	31.423	30.667	1324	1268
800SG200-54	0.829	7.181	1.795	2.944	0.367	0.666	0.885	6.840	-0.777	0.054	3.117	0.938	0.701	7.181	1.731	1.724	51.819	51.620	43.141	42.055	2632	1994
800SG200-68	1.040	8.960	2.240	2.935	0.455	0.662	1.763	8.484	-0.767	0.047	3.105	0.939	0.933	8.960	2.240	2.235	74.340	74.180	63.400	61.713	5300	3156
800SG200-97	1.473	12.530	3.133	2.917	0.629	0.653	5.078	11.713	-0.748	0.033	3.081	0.941	1.320	12.530	3.133	3.126	107.352	107.117	104.064	101.327	10888	4452
800SG250-33	0.544	5.002	1.250	3.033	0.382	0.838	0.217	6.837	-1.202	0.321	3.368	0.873	0.360	4.856	0.980	0.967	29.352	28.942	22.427	21.953	595	595
800SG250-43	0.707	6.478	1.620	3.027	0.493	0.835	0.479	8.833	-1.196	0.317	3.360	0.873	0.522	6.478	1.363	1.349	40.806	40.395	32.761	32.012	1324	1268
800SG250-54	0.885	8.074	2.019	3.020	0.612	0.832	0.945	10.975	-1.189	0.312	3.350	0.874	0.701	8.074	1.782	1.769	53.363	52.965	45.165	44.076	2632	1994
800SG250-68	1.111	10.081	2.520	3.012	0.761	0.827	1.883	13.649	-1.179	0.305	3.339	0.875	0.923	10.081	2.304	2.291	68.996	68.586	62.282	60.729	5300	3156
800SG250-97	1.575	14.116	3.529	2.994	1.055	0.818	5.428	18.950	-1.160	0.292	3.314	0.877	1.402	14.116	3.466	3.456	115.861	115.535	108.627	105.815	10888	4452
800SG300-43	0.752	7.192	1.798	3.092	0.767	1.010	0.510	13.119	-1.617	0.573	3.633	0.802	0.518	7.028	1.387	1.368	41.519	40.945	33.663	32.933	1324	1268
800SG300-54	0.942	8.967	2.242	3.086	0.954	1.006	1.006	16.324	-1.610	0.568	3.623	0.802	0.705	8.804	1.839	1.820	55.068	54.497	46.575	45.502	2632	1994

Table Background And Example

1. Basis For Tables:

The SigmaStud Combined Axial and Lateral Load tables in this catalog cover the following basic load combinations for the Allowable Stress Design (ASD) Method (IBC 2018 and ASCE 7-16). Listed wind pressures represent calculated design wind pressure (0.6W based on 2018 IBC).

- IBC 2018 / ASCE 7-16
 - i. $D + L$ (Strength Determination)
 - ii. $D + 0.75L + 0.75(0.6W_{MWFRS}^*)$ (Strength Determination)
 - iii. $D + 0.70(0.6W_{C\&C}^{**})$ (Deflection Determination)

* MWFRS: Main Wind Force Resisting System

** C&C: Component and Cladding

- For deflection determination IBC 2018 Sec. 1604.3 and AISI S240-15 North American Standard for Cold-Formed Steel Structural Framing Sec. B1.1.2. allow for a reduction factor of 0.7 on the component and cladding wind load (0.7WC&C).



2. Design Example:

Given:

Service (Un-factored) Loads:

Axial Dead Load	= 1.6 kips
Axial Live Load	= 3.2 kips
Wind Pressure ($0.6W_{MWFRS}$)(ASCE 7-16)	= 28 psf
Wind Pressure ($0.6W_{C\&C}$)(ASCE 7-16)	= 40 psf
Wall Width	= 6 in.
Stud Height	= 12 ft.
Stud Spacing	= 16 in. o.c.
Specified Deflection Limit	= L/360
Bridging (Lateral Bracing) at maximum vertical spacing of 48" o.c.	

Calculations:

- a) Use the $D + L$ load combination to get the first estimate of the stud.
 Combination total axial load = 1.6 kips + 3.2 kips = 4.8 kips
 From the "No Lateral Load" table with a 12 ft wall height, choose 600SG200-43 (50 ksi) with an axial resistance of 9.35 kips > 4.8 kips. **OK**
- b) Check the $D + 0.75L + 0.75(0.6W_{MWFRS})$ (IBC 2018 / ASCE 7-16) load combination for strength.
 Combination total axial load = 1.6 kips + 0.75(3.2 kips) = 4.0 kips
 $0.75(0.6W_{MWFRS}) = 0.75 \times 28 \text{ psf} = 21 \text{ psf}$ (approximately 20 psf)
 Go to the "Lateral Load = 20 psf" table with a 12 ft. wall height and 16 in. stud spacing. The axial resistance for 600SG200-43 (50 ksi) is 6.20 kips > 4.0 kips. **OK**
- c) Check the $0.70(0.6W_{C\&C})$ (IBC 2018 / ASCE 7-10) load combination for deflection.
 The specified limit is L/360.
 Go to the "Lateral Load = 40 psf" table with a 12 ft. wall height and 16 in. stud spacing. The deflection parameter for 600SG200-43 (50 ksi) is blank, which indicates that deflection is less than $L/720 < L/360$. **OK**

Conclusion:

Use 600SG200-43 (50 ksi) (with design thickness = 0.0451" and $F_y = 50 \text{ ksi}$) spaced at 16 in. o.c. with 2 lines of bridging arranged so that the maximum spacing does not exceed 48 in. (4 ft.)

3. Extra Design Considerations:

- a) Check lateral end reaction of the stud for web crippling if applicable.
- b) If the specified axial dead load acting on the stud is significantly larger than the specified axial live load, the following basic load combination needs to be checked as well:
 - IBC 2018 / ASCE 7-16
 - i. $D + (0.6W_{C\&C})$ (Strength Determination)

Load Bearing Wall Members

Combined Axial & Lateral Load Tables

Important Notes

1. Allowable loads are based on weak axis and torsional bracing at 48" o.c. maximum for axial load calculation, and continuous support of each flange for flexural calculation.
2. Sections are punched with a standard punch-out 1.5" wide located along the centerline of the web 24" o.c.
3. Allowable loads are based on checks for punched section under axial load, flexural, and shear conditions.
4. Weak axis and torsional bracing should have sufficient stiffness and strength to resist the axial load.
5. The allowable axial strength for distortional buckling is based on an assumed $k_{\phi} = 0$.
6. Strength increase due to cold forming is incorporated in calculating allowable loads as per AISI S100-16 Spec, Sec. A3.3.2 (3).
7. Contact The Steel Network if web crippling capacity values of SigmaStud® are required to check lateral end reactions.
8. Loads in tables are in kips/stud.

No Lateral Load (For Load Combination 1.0 [D+L]): Axial Compression Load (kips)																	
Wall Height (ft)	Spacing (in) o.c.	350SG200-(mils)					350SG250-(mils)					350SG350-(mils)	362SG200-(mils)				
		33	43	54	68	97	33	43	54	68	97	68	33	43	54	68	97
8	12, 16, 24	3.21	4.54	5.88	7.43	10.98	3.46	5.09	6.80	8.58	12.58	9.22	3.31	4.72	6.12	7.83	11.60
9	12, 16, 24	3.02	4.23	5.45	6.87	10.02	3.27	4.80	6.32	7.94	11.52	8.76	3.14	4.42	5.73	7.28	10.66
10	12, 16, 24	2.82	3.89	4.98	6.26	9.02	3.06	4.48	5.78	7.26	10.42	8.33	2.94	4.10	5.30	6.69	9.68
12	12, 16, 24	2.37	3.19	4.02	5.03	7.12	2.61	3.72	4.69	5.87	8.28	7.20	2.51	3.40	4.34	5.44	7.70
14	12, 16, 24	1.95	2.60	3.23	4.04	5.67	2.22	3.04	3.78	4.72	6.62	6.06	2.07	2.79	3.50	4.38	6.15
16	12, 16, 24	1.61	2.12	2.63	3.28	4.58	1.89	2.48	3.09	3.85	5.37	4.96	1.72	2.30	2.86	3.56	4.97

Wall Height (ft)	Spacing (in) o.c.	362SG250-(mils)					362SG350-(mils)	400SG200-(mils)					400SG250-(mils)				
		33	43	54	68	97	68	33	43	54	68	97	33	43	54	68	97
8	12, 16, 24	3.57	5.27	7.08	9.03	13.27	9.62	3.58	5.19	6.76	8.85	12.86	3.86	5.69	7.61	10.18	14.72
9	12, 16, 24	3.39	4.98	6.62	8.41	12.24	9.12	3.43	4.93	6.42	8.39	12.11	3.70	5.47	7.35	9.65	13.87
10	12, 16, 24	3.19	4.68	6.13	7.74	11.15	8.69	3.26	4.64	6.04	7.88	11.29	3.53	5.20	6.99	9.07	12.95
12	12, 16, 24	2.75	3.97	5.07	6.34	8.95	7.67	2.88	4.01	5.20	6.73	9.52	3.14	4.60	6.03	7.78	10.99
14	12, 16, 24	2.34	3.26	4.09	5.11	7.17	6.54	2.47	3.34	4.33	5.49	7.73	2.71	3.91	5.04	6.39	8.98
16	12, 16, 24	2.00	2.69	3.34	4.17	5.82	5.36	2.06	2.78	3.59	4.48	6.28	2.33	3.25	4.18	5.23	7.31

Wall Height (ft)	Spacing (in) o.c.	400SG350-(mils)			550SG162-(mils)		550SG200-(mils)					550SG250-(mils)					550SG300-(mils)				
		68	97	118	33	43	33	43	54	68	97	33	43	54	68	97	43	54	68	97	118
8	12, 16, 24	10.60	17.25	22.17	4.54	5.91	6.36	8.83	11.11	14.46	20.41	6.44	9.62	12.94	17.12	26.65	9.60	13.41	17.44	27.06	36.99
9	12, 16, 24	10.20	16.45	20.91	4.54	5.91	6.36	8.83	11.11	14.46	20.41	6.44	9.62	12.94	17.12	26.65	9.60	13.10	17.02	26.40	35.79
10	12, 16, 24	9.75	15.62	19.56	4.54	5.91	6.36	8.83	11.11	14.46	20.41	6.44	9.62	12.59	16.72	25.99	9.60	12.74	16.54	25.65	34.38
12	12, 16, 24	8.87	13.80	16.69	4.54	5.91	6.36	8.83	11.11	14.46	20.41	6.44	9.33	11.70	15.62	23.52	9.31	11.88	15.42	23.95	31.12
14	12, 16, 24	7.79	11.41	13.76	4.54	5.91	6.00	8.17	10.22	13.27	18.85	6.23	8.54	10.78	14.10	20.76	8.56	10.90	14.30	21.67	27.52
16	12, 16, 24	6.68	9.35	11.25	4.54	5.89	5.31	7.15	8.91	11.43	16.11	5.56	7.67	9.83	12.36	17.91	7.75	9.83	13.00	19.06	23.83

Wall Height (ft)	Spacing (in) o.c.	600SG162-(mils)		600SG200-(mils)					600SG250-(mils)					600SG300-(mils)				
		33	43	33	43	54	68	97	33	43	54	68	97	43	54	68	97	118
8	12, 16, 24	4.35	6.38	6.25	9.34	11.78	15.34	21.68	6.37	9.55	13.46	17.97	27.94	9.57	13.54	18.60	28.77	39.15
9	12, 16, 24	4.35	6.38	6.25	9.34	11.78	15.34	21.68	6.37	9.55	13.46	17.97	27.94	9.57	13.54	18.24	28.19	38.38
10	12, 16, 24	4.35	6.38	6.25	9.34	11.78	15.34	21.68	6.37	9.55	13.46	17.95	27.94	9.57	13.54	17.81	27.51	37.14
12	12, 16, 24	4.35	6.38	6.25	9.34	11.78	15.34	21.68	6.37	9.55	12.76	16.94	25.89	9.57	12.95	16.77	25.92	34.20
14	12, 16, 24	4.35	6.38	6.25	9.09	11.45	14.93	21.28	6.37	9.43	11.80	15.73	23.32	9.44	12.03	15.64	24.14	30.86
16	12, 16, 24	4.35	6.38	6.02	8.17	10.19	13.16	18.65	6.29	8.61	10.94	14.07	20.59	8.67	11.02	14.50	21.65	27.32

Wall Height (ft)	Spacing (in) o.c.	800SG162-(mils)		800SG200-(mils)					800SG250-(mils)					800SG300-(mils)				
		33	43	33	43	54	68	97	33	43	54	68	97	43	54	68	97	118
8	12, 16, 24	3.56	5.39	5.60	8.47	12.05	17.19	26.17	5.93	8.97	12.77	18.24	31.28	9.21	13.13	18.79	32.35	43.50
9	12, 16, 24	3.56	5.39	5.60	8.47	12.05	17.19	26.17	5.93	8.97	12.77	18.24	31.28	9.21	13.13	18.79	32.35	43.50
10	12, 16, 24	3.56	5.39	5.60	8.47	12.05	17.19	26.17	5.93	8.97	12.77	18.24	31.28	9.21	13.13	18.79	32.35	43.50
12	12, 16, 24	3.56	5.39	5.60	8.47	12.05	17.19	26.17	5.93	8.97	12.77	18.24	31.28	9.21	13.13	18.79	32.35	43.50
14	12, 16, 24	3.56	5.39	5.60	8.47	12.05	17.19	26.17	5.93	8.97	12.77	18.24	31.28	9.21	13.13	18.79	31.82	42.35
16	12, 16, 24	3.56	5.39	5.60	8.47	12.05	17.19	26.17	5.93	8.97	12.77	18.24	30.07	9.21	13.13	18.79	30.21	39.55

Important Notes:

- Allowable loads are based on weak axis and torsional bracing at 48" o.c. maximum for axial load calculation and continuous support of each flange for flexural calculation.
- Sections are punched with a standard punch-out 1.5" wide located along the centerline of the web 24" o.c.
- Allowable loads are based on checks for punched section under axial load, flexural, and shear conditions.
- Weak axis and torsional bracing should have sufficient stiffness and strength to resist the axial load.
- The allowable axial strength for distortional buckling is based on an assumed $k_y = 0$.
- Lateral loads have not been modified for strength checks: full loads are applied.
- Listed wind pressures represent calculated design wind pressure (0.6W based on 2018 IBC).
- 15 psf and higher wind pressures have been multiplied by 0.7 for deflection determination, in accordance with footnote "f" of IBC table 1604.3. The 5 psf pressure has not been reduced for deflection checks.
- 5 psf is classified as live transverse loads, not wind loads, per 2018 IBC Section 1607.14.
- Strength increase due to cold forming is incorporated in calculating allowable loads as per AISI S100-16 Spec, Sec. A3.3.2 (3).
- Moment of inertia for deflection is optimized based on the maximum moment at service loads for the listed spans; therefore; span values may be greater than spans based on an effective moment of inertia listed in section property tables.
- Contact The Steel Network if web crippling capacity values of SigmaStud® are required to check lateral end reactions.
- Loads in tables are in kips/stud.

5 Psf Lateral Load: Axial Compression Load (kips)																	
Wall Height (ft)	Spacing (in) o.c.	350SG200-(mils)					350SG250-(mils)					350SG350-(mils)	362SG200-(mils)				
		33	43	54	68	97	33	43	54	68	97	68	33	43	54	68	97
8	12	3.03	4.36	5.70	7.26	10.82	3.28	4.90	6.60	8.39	12.42	9.02	3.13	4.54	5.95	7.66	11.44
	16	2.96	4.30	5.64	7.20	10.77	3.21	4.83	6.53	8.33	12.36	8.96	3.07	4.48	5.89	7.60	11.38
	24	2.84	4.18	5.52	7.09	10.66	3.09	4.70	6.40	8.20	12.26	8.83	2.95	4.35	5.77	7.49	11.28
9	12	2.80	4.01	5.24	6.66	9.84	3.05	4.56	6.08	7.72	11.33	8.53	2.92	4.20	5.51	7.07	10.48
	16	2.73	3.94	5.17	6.60	9.78	2.97	4.49	6.00	7.64	11.27	8.45	2.84	4.13	5.44	7.01	10.41
	24	2.58	3.79	5.03	6.46	9.65	2.82	4.33	5.84	7.50	11.14	8.30	2.70	3.99	5.30	6.87	10.29
10	12	2.56	3.64	4.74	6.03	8.82	2.80	4.21	5.52	7.01	10.21	8.06	2.69	3.85	5.05	6.46	9.47
	16	2.48	3.56	4.66	5.96	8.75	2.72	4.12	5.43	6.93	10.14	7.97	2.60	3.76	4.97	6.38	9.40
	24	2.31	3.40	4.51	5.81	8.61	2.54	3.94	5.25	6.76	10.00	7.79	2.43	3.60	4.81	6.22	9.26
12	12	2.07	2.90	3.74	4.77	6.88	2.30	3.40	4.38	5.58	8.04	6.87	2.20	3.10	4.06	5.17	7.46
	16	1.96	2.80	3.65	4.68	6.80	2.19	3.29	4.28	5.48	7.95	6.75	2.09	3.00	3.96	5.08	7.38
	24	1.76 ⁶	2.61	3.47	4.50	6.65	1.98 ⁷	3.08	4.07	5.29	7.79	6.53	1.89 ⁷	2.80	3.77	4.90	7.22
14	12	1.60	2.27	2.93	3.75	5.41	1.85	2.68	3.44	4.40	6.36	5.67	1.72	2.46	3.19	4.08	5.89
	16	1.49 ⁶	2.17 ⁷	2.83	3.65	5.33	1.73 ⁷	2.56	3.33	4.30	6.27	5.54	1.61 ⁶	2.35	3.09	3.98	5.80
	24	1.26 ⁶	1.95 ⁶	2.63 ⁶	3.46 ⁷	5.16	1.48 ⁶	2.32 ⁶	3.10 ⁷	4.09	6.10	5.29	1.37 ⁶	2.12 ⁶	2.88 ⁷	3.78	5.62
16	12	1.24 ⁶	1.77 ⁷	2.31	2.97	4.31	1.48 ⁶	2.10	2.72	3.51	5.09	4.55	1.34 ⁶	1.94 ⁷	2.52	3.24	4.70
	16	1.11 ⁶	1.66 ⁶	2.21 ⁶	2.87 ⁷	4.22	1.34 ⁶	1.97 ⁶	2.60 ⁷	3.39	5.00	4.41	1.21 ⁶	1.82 ⁶	2.41 ⁷	3.14	4.60
	24	0.87 ³	1.43 ³	1.99 ⁶	2.67 ⁶	4.04 ⁷	1.07 ³	1.72 ⁶	2.36 ⁶	3.17 ⁶	4.81	4.14 ⁷	0.96 ³	1.58 ³	2.19 ⁶	2.93 ⁶	4.42 ⁷

5 Psf Lateral Load: Axial Compression Load (kips)																	
Wall Height (ft)	Spacing (in) o.c.	362SG250-(mils)					362SG350-(mils)	400SG200-(mils)					400SG250-(mils)				
		33	43	54	68	97	68	33	43	54	68	97	33	43	54	68	97
8	12	3.39	5.07	6.88	8.84	13.11	9.42	3.40	5.01	6.58	8.67	12.68	3.68	5.51	7.42	9.99	14.55
	16	3.32	5.01	6.81	8.78	13.06	9.36	3.35	4.95	6.52	8.62	12.62	3.62	5.44	7.35	9.93	14.49
	24	3.20	4.88	6.68	8.65	12.95	9.23	3.23	4.83	6.41	8.50	12.51	3.50	5.32	7.23	9.80	14.37
9	12	3.17	4.75	6.39	8.18	12.05	8.89	3.22	4.71	6.21	8.18	11.90	3.48	5.24	7.11	9.42	13.66
	16	3.09	4.67	6.31	8.11	11.98	8.82	3.14	4.64	6.14	8.11	11.83	3.41	5.17	7.04	9.34	13.59
	24	2.94	4.52	6.15	7.96	11.86	8.67	3.00	4.49	6.00	7.97	11.69	3.26	5.02	6.88	9.19	13.45
10	12	2.93	4.41	5.86	7.48	10.94	8.42	3.01	4.39	5.79	7.64	11.05	3.27	4.94	6.71	8.80	12.71
	16	2.84	4.32	5.77	7.40	10.86	8.33	2.93	4.30	5.71	7.56	10.96	3.18	4.85	6.62	8.71	12.63
	24	2.67	4.14	5.59	7.23	10.72	8.15	2.76	4.14	5.55	7.40	10.80	3.01	4.67	6.44	8.54	12.47
12	12	2.43	3.64	4.74	6.04	8.70	7.33	2.56	3.69	4.90	6.43	9.23	2.81	4.26	5.69	7.45	10.69
	16	2.32	3.53	4.64	5.94	8.61	7.22	2.45	3.59	4.80	6.33	9.13	2.70	4.15	5.58	7.34	10.59
	24	2.11	3.31	4.42	5.74	8.45	6.99	2.24	3.38	4.60	6.14	8.93	2.48	3.93	5.35	7.13	10.40
14	12	1.97	2.89	3.74	4.78	6.90	6.14	2.09	2.99	3.98	5.17	7.40	2.32	3.51	4.65	6.02	8.65
	16	1.84 ⁷	2.77	3.62	4.67	6.81	6.01	1.97	2.87	3.87	5.06	7.29	2.19	3.38	4.52	5.90	8.54
	24	1.59 ⁶	2.52 ⁶	3.39	4.45	6.63	5.74	1.72 ⁶	2.63 ⁷	3.64	4.84	7.07	1.93 ⁶	3.12	4.26	5.66	8.32
16	12	1.58 ⁷	2.29	2.97	3.82	5.53	4.93	1.65 ⁷	2.40	3.22	4.14	5.93	1.89	2.82	3.76	4.84	6.97
	16	1.44 ⁶	2.16 ⁶	2.84	3.70	5.44	4.79	1.51 ⁶	2.27 ⁷	3.10	4.02	5.81	1.75 ⁶	2.68	3.62	4.70	6.85
	24	1.16 ³	1.90 ⁶	2.59 ⁶	3.46 ⁷	5.25	4.51	1.24 ³	2.01 ⁶	2.85 ⁶	3.79 ⁷	5.58	1.46 ⁶	2.40 ⁶	3.34 ⁷	4.44	6.62

1 = Deflection Exceeds L/120
2 = Deflection Exceeds L/240

3 = Deflection Exceeds L/360
6 = Deflection Exceeds L/600

7 = Deflection Exceeds L/720
If not noted, deflection is less than L/720

Load Bearing Wall Members

Combined Axial & Lateral Load Tables

Refer to Important Table Notes on Page 9

5 Psf Lateral Load: Axial Compression Load (kips)																					
Wall Height (ft)	Spacing (in) o.c.	400SG350-(mils)			550SG162-(mils)			550SG200-(mils)			550SG250-(mils)			550SG300-(mils)							
		68	97	118	33	43	33	43	54	68	97	33	43	54	68	97	43	54	68	97	118
8	12	10.42	17.06	21.98	4.34	5.73	6.15	8.63	10.92	14.29	20.26	6.23	9.41	12.73	16.92	26.47	9.39	13.20	17.24	26.87	36.80
	16	10.35	17.00	21.92	4.28	5.67	6.08	8.56	10.85	14.24	20.21	6.16	9.34	12.66	16.85	26.41	9.33	13.13	17.17	26.80	36.74
	24	10.23	16.87	21.80	4.15	5.56	5.94	8.42	10.73	14.12	20.11	6.03	9.19	12.52	16.72	26.28	9.19	12.99	17.04	26.68	36.61
9	12	9.97	16.22	20.69	4.29	5.69	6.10	8.57	10.87	14.25	20.22	6.18	9.35	12.67	16.87	26.42	9.34	12.84	16.78	26.17	35.55
	16	9.90	16.15	20.62	4.21	5.61	6.01	8.49	10.79	14.18	20.16	6.09	9.26	12.58	16.78	26.34	9.25	12.76	16.70	26.09	35.48
	24	9.74	15.99	20.47	4.05	5.47	5.83	8.31	10.63	14.03	20.03	5.92	9.08	12.41	16.61	26.18	9.08	12.59	16.53	25.93	35.32
10	12	9.48	15.35	19.30	4.23	5.63	6.03	8.51	10.81	14.20	20.18	6.11	9.29	12.27	16.41	25.70	9.28	12.43	16.25	25.36	34.10
	16	9.39	15.26	19.22	4.13	5.54	5.92	8.40	10.71	14.11	20.10	6.01	9.18	12.17	16.31	25.61	9.17	12.33	16.15	25.27	34.00
	24	9.21	15.08	19.05	3.93	5.36	5.70	8.19	10.52	13.93	19.94	5.79	8.96	11.95	16.10	25.42	8.96	12.12	15.95	25.08	33.82
12	12	8.52	13.46	16.38	4.10	5.51	5.89	8.37	10.68	14.08	20.07	5.97	8.87	11.28	15.21	23.15	8.87	11.46	15.03	23.56	30.76
	16	8.40	13.35	16.28	3.96	5.38	5.73	8.22	10.54	13.96	19.96	5.82	8.72	11.13	15.07	23.03	8.72	11.33	14.89	23.44	30.64
	24	8.17	13.12	16.08	3.67	5.12	5.41	7.91	10.26	13.70	19.73	5.51	8.41	10.85	14.79	22.79	8.42	11.05	14.63	23.18	30.40
14	12	7.36	11.03	13.42	3.94	5.37	5.39	7.59	9.69	12.80	18.42	5.63	7.96	10.24	13.58	20.32	8.00	10.38	13.80	21.20	27.09
	16	7.22	10.90	13.30	3.75	5.19	5.19	7.40	9.51	12.64	18.28	5.42	7.77	10.07	13.41	20.17	7.81	10.20	13.63	21.05	26.94
	24	6.94	10.65	13.07	3.35	4.84	4.78	7.01	9.16	12.32	18.00	5.02	7.38	9.71	13.07	19.88	7.44	9.86	13.30	20.73	26.65
16	12	6.20	8.94	10.88	3.76	5.19	4.60	6.49	8.30	10.89	15.64	4.85	6.99	9.19	11.77	17.42	7.09	9.22	12.40	18.52	23.33
	16	6.05	8.80	10.76	3.51	4.96	4.37	6.27	8.10	10.71	15.48	4.62	6.76	8.98	11.57	17.25	6.86	9.02	12.21	18.34	23.17
	24	5.73	8.53	10.51	2.99 ¹	4.50	3.90	5.83	7.70	10.35	15.16	4.14	6.31	8.55	11.18	16.92	6.42	8.61	11.81	17.98	22.84

5 Psf Lateral Load: Axial Compression Load (kips)																		
Wall Height (ft)	Spacing (in) o.c.	600SG162-(mils)		600SG200-(mils)				600SG250-(mils)					600SG300-(mils)					
		33	43	33	43	54	68	97	33	43	54	68	97	43	54	68	97	118
8	12	4.18	6.20	6.06	9.14	11.59	15.17	21.53	6.19	9.36	13.26	17.78	27.76	9.38	13.34	18.40	28.58	38.97
	16	4.12	6.15	6.00	9.08	11.53	15.12	21.49	6.13	9.29	13.19	17.71	27.70	9.32	13.28	18.34	28.52	38.91
	24	4.01	6.03	5.87	8.95	11.41	15.01	21.39	6.00	9.17	13.06	17.58	27.59	9.20	13.15	18.21	28.40	38.79
9	12	4.13	6.16	6.01	9.09	11.55	15.13	21.49	6.14	9.31	13.21	17.73	27.71	9.33	13.29	18.00	27.96	38.16
	16	4.06	6.08	5.93	9.01	11.47	15.06	21.43	6.06	9.23	13.12	17.65	27.64	9.25	13.21	17.92	27.89	38.08
	24	3.92	5.94	5.77	8.84	11.31	14.92	21.31	5.90	9.06	12.96	17.48	27.49	9.10	13.05	17.76	27.73	37.93
10	12	4.08	6.11	5.96	9.03	11.49	15.08	21.45	6.08	9.25	13.15	17.65	27.66	9.28	13.23	17.52	27.24	36.87
	16	3.99	6.02	5.86	8.93	11.40	15.00	21.38	5.99	9.15	13.05	17.55	27.57	9.18	13.13	17.43	27.14	36.78
	24	3.81	5.83	5.66	8.72	11.21	14.83	21.23	5.79	8.95	12.84	17.34	27.39	8.98	12.93	17.23	26.96	36.61
12	12	3.96	5.99	5.82	8.90	11.37	14.97	21.35	5.95	9.12	12.34	16.52	25.52	9.15	12.53	16.38	25.54	33.85
	16	3.84	5.86	5.68	8.75	11.23	14.85	21.25	5.81	8.97	12.20	16.39	25.40	9.01	12.39	16.25	25.42	33.73
	24	3.58	5.60	5.40	8.45	10.95	14.60	21.03	5.53	8.68	11.91	16.11	25.15	8.73	12.12	15.99	25.17	33.49
14	12	3.83	5.85	5.67	8.50	10.90	14.45	20.85	5.80	8.84	11.27	15.21	22.87	8.88	11.50	15.15	23.66	30.42
	16	3.65	5.67	5.48	8.31	10.72	14.28	20.70	5.61	8.65	11.09	15.04	22.72	8.69	11.33	14.98	23.50	30.27
	24	3.30	5.31	5.09	7.92	10.36	13.96	20.41	5.23	8.26	10.73	14.69	22.42	8.31	10.98	14.65	23.18	29.98
16	12	3.67	5.68	5.29	7.48	9.56	12.60	18.15	5.55	7.91	10.30	13.46	20.07	7.99	10.39	13.89	21.09	26.81
	16	3.44	5.45	5.05	7.25	9.35	12.41	17.99	5.31	7.68	10.08	13.26	19.90	7.76	10.18	13.69	20.90	26.64
	24	2.98 ²	4.99	4.56	6.79	8.93	12.04	17.65	4.81	7.22	9.65	12.85	19.55	7.31	9.76	13.29	20.53	26.31

5 Psf Lateral Load: Axial Compression Load (kips)																		
Wall Height (ft)	Spacing (in) o.c.	800SG162-(mils)		800SG200-(mils)					800SG250-(mils)					800SG300-(mils)				
		33	43	33	43	54	68	97	33	43	54	68	97	43	54	68	97	118
8	12	3.45	5.28	5.47	8.33	11.91	17.06	26.05	5.80	8.84	12.63	18.10	31.14	9.08	12.99	18.65	32.20	43.35
	16	3.41	5.25	5.43	8.29	11.86	17.01	26.00	5.76	8.79	12.59	18.05	31.09	9.03	12.95	18.60	32.15	43.30
	24	3.34	5.17	5.34	8.20	11.77	16.92	25.92	5.67	8.70	12.49	17.95	31.00	8.94	12.85	18.50	32.05	43.21
9	12	3.42	5.25	5.44	8.30	11.87	17.02	26.01	5.77	8.80	12.60	18.06	31.10	9.04	12.95	18.61	32.16	43.31
	16	3.38	5.21	5.38	8.24	11.81	16.96	25.96	5.71	8.74	12.54	18.00	31.04	8.98	12.90	18.55	32.10	43.25
	24	3.29	5.11	5.27	8.13	11.70	16.85	25.86	5.60	8.63	12.42	17.88	30.92	8.87	12.78	18.43	31.97	43.13
10	12	3.39	5.22	5.40	8.26	11.83	16.98	25.98	5.73	8.76	12.55	18.02	31.06	9.00	12.91	18.56	32.11	43.27
	16	3.33	5.16	5.33	8.19	11.76	16.91	25.91	5.66	8.69	12.48	17.94	30.98	8.93	12.84	18.49	32.04	43.20
	24	3.22	5.05	5.20	8.05	11.62	16.77	25.78	5.52	8.55	12.34	17.79	30.84	8.79	12.70	18.34	31.88	43.05
12	12	3.32	5.14	5.31	8.17	11.74	16.89	25.89	5.64	8.67	12.46	17.92	30.96	8.91	12.82	18.47	32.01	43.17
	16	3.24	5.06	5.22	8.07	11.63	16.79	25.80	5.54	8.57	12.36	17.81	30.85	8.81	12.71	18.36	31.90	43.07
	24	3.07	4.89	5.02	7.87	11.43	16.59	25.61	5.35	8.37	12.15	17.59	30.64	8.61	12.51	18.15	31.67	42.85
14	12	3.23	5.05	5.21	8.06	11.62	16.78	25.79	5.53	8.56	12.35	17.80	30.85	8.80	12.71	18.35	31.36	41.92
	16	3.12	4.94	5.08	7.92	11.48	16.64	25.66	5.40	8.42	12.20	17.65	30.70	8.66	12.56	18.20	31.21	41.77
	24	2.90	4.71	4.82	7.65	11.20	16.37	25.41	5.14	8.15	11.92	17.36	30.41	8.39	12.28	17.91	30.90	41.49
16	12	3.13	4.95	5.09	7.93	11.49	16.66	25.67	5.41	8.43	12.22	17.67	29.52	8.67	12.58	18.22	29.64	39.02
	16	2.98	4.80	4.92	7.76	11.31	16.48	25.51	5.24	8.25	12.03	17.47	29.34	8.49	12.39	18.03	29.45	38.85
	24	2.70	4.50	4.58	7.40	10.94	16.12	25.18	4.89	7.90	11.66	17.09	28.98	8.14	12.02	17.64	29.07	38.50

1 = Deflection Exceeds L/120
2 = Deflection Exceeds L/240

3 = Deflection Exceeds L/360
6 = Deflection Exceeds L/600

7 = Deflection Exceeds L/720
If not noted, deflection is less than L/720

Load Bearing Wall Members

Combined Axial & Lateral Load Tables

Refer to Important Table Notes on Page 9

20 Psf Lateral Load: Axial Compression Load (kips)																		
Wall Height (ft)	Spacing (in) o.c.	350SG200-(mils)					350SG250-(mils)					350SG350-(mils)		362SG200-(mils)				
		33	43	54	68	97	33	43	54	68	97	68	33	43	54	68	97	
8	12	2.47	3.81	5.16	6.74	10.34	2.71	4.31	6.00	7.83	11.93	8.45	2.58	3.99	5.41	7.14	10.95	
	16	2.22	3.56	4.93	6.51	10.13	2.46	4.05	5.73	7.57	11.71	8.20	2.34	3.74	5.17	6.91	10.74	
	24	1.73 ⁷	3.07	4.45	6.05	9.70	1.96	3.53	5.20	7.07	11.28	7.69	1.85	3.25	4.70	6.44	10.31	
9	12	2.14	3.36	4.61	6.06	9.28	2.37	3.86	5.37	7.05	10.77	7.84	2.26	3.55	4.88	6.46	9.91	
	16	1.85	3.07	4.33	5.79	9.03	2.08	3.55	5.06	6.76	10.51	7.53	1.96	3.26	4.60	6.19	9.66	
	24	1.26 ⁶	2.49 ⁷	3.78	5.25	8.54	1.48 ⁶	2.93	4.43	6.17	10.01	6.92	1.38 ⁶	2.68 ⁷	4.04	5.65	9.16	
10	12	1.80 ⁷	2.90	4.04	5.35	8.20	2.03	3.40	4.72	6.26	9.58	7.25	1.92	3.10	4.33	5.76	8.84	
	16	1.47 ⁶	2.57 ⁷	3.72	5.05	7.92	1.68 ⁷	3.04	4.37	5.93	9.29	6.89	1.58 ⁶	2.77	4.01	5.45	8.55	
	24	0.79 ³	1.92 ⁶	3.09 ⁶	4.44 ⁷	7.37	0.99 ⁶	2.33 ⁶	3.66 ⁷	5.26	8.73	6.17	0.91 ⁶	2.10 ⁶	3.37 ⁷	4.83	7.99	
12	12	1.14 ⁶	2.02 ⁶	2.92 ⁷	3.98	6.18	1.34 ⁶	2.44 ⁷	3.45	4.71	7.31	5.86	1.26 ⁶	2.21 ⁶	3.21 ⁷	4.36	6.74	
	16	0.73 ³	1.64 ⁶	2.55 ⁶	3.63 ⁷	5.87	0.92 ³	2.01 ⁶	3.03 ⁶	4.32 ⁷	6.99	5.41	0.84 ³	1.81 ⁶	2.83 ⁶	3.99 ⁷	6.42	
	24		0.86 ³	1.82 ³	2.92 ⁶	5.24 ⁶	0.07 ²	1.15 ³	2.21 ⁶	3.54 ⁶	6.34 ⁷	4.52 ⁷	0.01 ²	1.02 ³	2.07 ³	3.27 ⁶	5.77 ⁷	
14	12	0.57 ³	1.30 ³	2.03 ⁶	2.89 ⁶	4.65 ⁷	0.75 ³	1.61 ⁶	2.42 ⁶	3.45 ⁶	5.57	4.52	0.67 ³	1.46 ⁶	2.26 ⁶	3.19 ⁶	5.10	
	16	0.11 ²	0.87 ³	1.63 ³	2.50 ⁶	4.31 ⁶	0.26 ²	1.13 ³	1.97 ³	3.03 ⁶	5.22 ⁷	4.01 ⁶	0.20 ²	1.01 ³	1.84 ³	2.79 ⁶	4.75 ⁶	
	24		0.01 ²	0.83 ²	1.74 ³	3.64 ³		0.18 ²	1.06 ²	2.18 ³	4.52 ⁶	2.98 ⁶		0.13 ²	1.01 ²	2.00 ³	4.05 ⁶	
16	12	0.13 ²	0.74 ²	1.35 ³	2.06 ³	3.51 ⁶	0.25 ²	0.96 ³	1.63 ³	2.49 ⁶	4.26 ⁶	3.32 ⁶	0.20 ²	0.86 ³	1.53 ³	2.30 ⁶	3.87 ⁶	
	16		0.28 ²	0.93 ²	1.65 ³	3.15 ³		0.45 ²	1.15 ³	2.04 ³	3.88 ⁶	2.77 ⁶		0.39 ²	1.08 ²	1.88 ³	3.50 ⁶	
	24			0.08 ²	0.84 ²	2.44 ²			0.18 ²	1.14 ²	3.14 ³	1.67 ³			0.20 ²	1.03 ²	2.76 ³	

20 Psf Lateral Load: Axial Compression Load (kips)																		
Wall Height (ft)	Spacing (in) o.c.	362SG250-(mils)					362SG350-(mils)		400SG200-(mils)					400SG250-(mils)				
		33	43	54	68	97	68	33	43	54	68	97	33	43	54	68	97	
8	12	2.83	4.49	6.28	8.27	12.62	8.85	2.87	4.47	6.06	8.16	12.15	3.14	4.95	6.85	9.42	14.02	
	16	2.58	4.23	6.02	8.02	12.40	8.60	2.64	4.23	5.83	7.93	11.91	2.90	4.70	6.59	9.17	13.79	
	24	2.08	3.71	5.48	7.51	11.96	8.09	2.16	3.75	5.36	7.47	11.44	2.41	4.20	6.08	8.66	13.32	
9	12	2.50	4.06	5.68	7.51	11.47	8.21	2.57	4.06	5.58	7.56	11.26	2.82	4.56	6.41	8.74	13.04	
	16	2.20	3.75	5.36	7.21	11.22	7.90	2.29	3.77	5.30	7.29	10.98	2.53	4.26	6.10	8.43	12.76	
	24	1.60 ⁷	3.13	4.73	6.61	10.71	7.29	1.71 ⁷	3.19	4.74	6.74	10.41	1.95	3.65	5.48	7.82	12.20	
10	12	2.15	3.60	5.05	6.72	10.29	7.61	2.25	3.63	5.06	6.92	10.31	2.50	4.14	5.89	8.01	11.99	
	16	1.81 ⁷	3.24	4.69	6.38	10.00	7.25	1.92	3.30	4.74	6.60	9.99	2.15	3.78	5.53	7.65	11.67	
	24	1.11 ⁶	2.52 ⁶	3.97 ⁷	5.70	9.43	6.53	1.24 ⁶	2.63 ⁷	4.08	5.96	9.34	1.46 ⁶	3.07	4.80	6.95	11.03	
12	12	1.46 ⁶	2.66 ⁷	3.78	5.14	7.95	6.30	1.60 ⁶	2.75 ⁷	3.99	5.55	8.34	1.82 ⁷	3.25	4.67	6.47	9.81	
	16	1.03 ⁶	2.22 ⁶	3.35 ⁷	4.74	7.62	5.85	1.17 ⁶	2.34 ⁶	3.59 ⁷	5.16	7.94	1.38 ⁶	2.79 ⁷	4.22	6.03	9.42	
	24	0.17 ³	1.34 ³	2.50 ⁶	3.94 ⁶	6.95 ⁷	4.93 ⁷	0.32 ³	1.50 ³	2.78 ⁶	4.37 ⁶	7.15	0.50 ³	1.89 ⁶	3.31 ⁶	5.16 ⁷	8.64	
14	12	0.85 ³	1.79 ⁶	2.68 ⁶	3.79 ⁷	6.09	4.95	0.97 ³	1.92 ⁶	2.96 ⁶	4.18 ⁷	6.42	1.16 ⁶	2.34 ⁶	3.49 ⁷	4.93	7.67	
	16	0.35 ³	1.30 ³	2.21 ⁶	3.35 ⁶	5.72 ⁷	4.42 ⁷	0.47 ³	1.45 ³	2.50 ⁶	3.75 ⁶	5.98 ⁷	0.64 ³	1.81 ⁶	2.97 ⁶	4.44 ⁷	7.24	
	24		0.32 ²	1.27 ³	2.47 ³	5.00 ⁶	3.36 ⁶		0.50 ²	1.59 ³	2.88 ³	5.11 ⁶		0.77 ³	1.94 ³	3.46 ⁶	6.37 ⁶	
16	12	0.33 ²	1.10 ³	1.84 ³	2.76 ⁶	4.67 ⁶	3.66 ⁶	0.43 ²	1.24 ³	2.11 ⁶	3.09 ⁶	4.89 ⁷	0.59 ³	1.54 ³	2.50 ⁶	3.66 ⁶	5.92	
	16		0.58 ²	1.33 ³	2.29 ³	4.29 ⁶	3.09 ⁶		0.72 ²	1.61 ³	2.63 ³	4.42 ⁶	0.01 ²	0.98 ³	1.94 ³	3.14 ⁶	5.46 ⁶	
	24			0.33 ²	1.36 ²	3.52 ³	1.96 ³			0.62 ²	1.70 ²	3.50 ³			0.83 ²	2.10 ³	4.54 ⁶	

20 Psf Lateral Load: Axial Compression Load (kips)																					
Wall Height (ft)	Spacing (in) o.c.	400SG350-(mils)			550SG162-(mils)		550SG200-(mils)					550SG250-(mils)					550SG300-(mils)				
		68	97	118	33	43	33	43	54	68	97	33	43	54	68	97	43	54	68	97	118
8	12	9.85	16.50	21.44	3.76	5.21	5.52	8.01	10.35	13.78	19.81	5.61	8.77	12.10	16.31	25.91	8.78	12.57	16.64	26.29	36.23
	16	9.61	16.25	21.20	3.51	4.97	5.24	7.74	10.10	13.56	19.60	5.34	8.49	11.82	16.04	25.67	8.51	12.30	16.38	26.04	35.98
	24	9.11	15.75	20.71	2.99	4.51	4.67	7.20	9.59	13.11	19.20	4.79	7.92	11.26	15.50	25.17	7.96	11.74	15.85	25.52	35.47
9	12	9.29	15.54	20.04	3.56	5.02	5.29	7.80	10.15	13.61	19.65	5.40	8.54	11.88	16.09	25.72	8.56	12.07	16.05	25.46	34.85
	16	8.98	15.24	19.75	3.23	4.73	4.94	7.45	9.83	13.32	19.39	5.05	8.19	11.52	15.75	25.41	8.22	11.73	15.72	25.14	34.54
	24	8.38	14.63	19.17	2.58	4.14	4.23	6.76	9.19	12.75	18.88	4.36	7.47	10.82	15.07	24.78	7.52	11.04	15.07	24.51	33.92
10	12	8.68	14.55	18.55	3.33	4.81	5.04	7.55	9.92	13.40	19.47	5.15	8.29	11.32	15.48	24.86	8.32	11.50	15.37	24.51	33.27
	16	8.32	14.20	18.22	2.92	4.45	4.60	7.13	9.53	13.05	19.15	4.73	7.85	10.89	15.07	24.48	7.89	11.09	14.97	24.13	32.90
	24	7.60	13.49	17.55	2.12	3.72	3.72	6.28	8.74	12.34	18.52	3.87	6.97	10.04	14.24	23.73	7.04	10.26	14.19	23.37	32.16
12	12	7.47	12.44	15.46	2.80	4.33	4.46	6.99	9.41	12.94	19.05	4.59	7.48	10.00	13.95	22.05	7.52	10.22	13.84	22.42	29.67
	16	7.00	11.99	15.05	2.22	3.81	3.83	6.38	8.84	12.43	18.60	3.97	6.86	9.43	13.40	21.56	6.93	9.66	13.32	21.91	29.19
	24	6.06	11.09	14.23	1.06 ⁶	2.76 ⁷	2.56 ⁷	5.16	7.70	11.41	17.69	2.74 ⁷	5.63	8.30	12.29	20.59	5.74	8.55	12.27	20.89	28.23
14	12	6.10	9.89	12.38	2.17 ⁷	3.76	3.56	5.86	8.09	11.37	17.14	3.80	6.23	8.64	12.05	18.99	6.32	8.82	12.31	19.79	25.79
	16	5.54	9.38	11.92	1.38 ⁶	3.05 ⁷	2.75 ⁶	5.09	7.38	10.73	16.57	2.99 ⁷	5.46	7.93	11.36	18.41	5.57	8.12	11.64	19.16	25.21
	24	4.42 ⁶	8.37 ⁷	11.00		1.62 ⁶	1.12 ⁶	3.55													

Load Bearing Wall Members

Combined Axial & Lateral Load Tables

Refer to Important Table Notes on Page 9

20 Psf Lateral Load: Axial Compression Load (kips)																		
Wall Height (ft)	Spacing (in) o.c.	600SG162-(mils)			600SG200-(mils)				600SG250-(mils)					600SG300-(mils)				
		33	43	54	33	43	54	68	97	33	43	54	68	97	43	54	68	97
8	12	3.67	5.68	5.49	8.55	11.05	14.68	21.10	5.63	8.78	12.66	17.20	27.23	8.82	12.76	17.82	28.03	38.43
	16	3.44	5.45	5.24	8.29	10.80	14.47	20.91	5.38	8.52	12.40	16.94	27.00	8.57	12.51	17.57	27.78	38.18
	24	2.98	4.99	4.73	7.76	10.31	14.03	20.53	4.88	8.01	11.87	16.42	26.53	8.07	11.99	17.05	27.29	37.70
9	12	3.48	5.50	5.29	8.34	10.85	14.51	20.95	5.43	8.58	12.45	16.99	27.05	8.62	12.56	17.28	27.27	37.48
	16	3.20	5.21	4.97	8.01	10.54	14.23	20.71	5.12	8.25	12.12	16.66	26.75	8.31	12.23	16.96	26.97	37.18
	24	2.62	4.62	4.33	7.35	9.93	13.68	20.22	4.49	7.60	11.45	16.01	26.16	7.67	11.58	16.32	26.35	36.59
10	12	3.28	5.29	5.07	8.11	10.64	14.31	20.78	5.21	8.35	12.22	16.74	26.84	8.40	12.33	16.66	26.41	36.07
	16	2.93	4.93	4.67	7.70	10.25	13.97	20.48	4.82	7.95	11.80	16.33	26.47	8.01	11.93	16.27	26.04	35.71
	24	2.21	4.21	3.88	6.88	9.49	13.29	19.88	4.04	7.14	10.97	15.53	25.74	7.23	11.13	15.50	25.30	35.00
12	12	2.81	4.82	4.54	7.57	10.13	13.87	20.38	4.70	7.82	11.07	15.29	24.42	7.89	11.29	15.20	24.42	32.78
	16	2.30	4.30	3.97	6.98	9.58	13.37	19.95	4.14	7.24	10.50	14.74	23.93	7.32	10.73	14.68	23.91	32.30
	24	1.28 ⁷	3.25	2.83	5.79	8.49	12.39	19.09	3.02	6.08	9.37	13.64	22.96	6.20	9.63	13.64	22.91	31.36
14	12	2.26	4.25	3.93	6.74	9.27	12.98	19.55	4.09	7.09	9.67	13.65	21.52	7.18	9.93	13.66	22.23	29.11
	16	1.56 ⁶	3.54	3.15 ⁷	5.96	8.55	12.33	18.97	3.33	6.32	8.96	12.95	20.92	6.43	9.23	12.99	21.60	28.53
	24	0.17 ⁶	2.13 ⁶	1.60 ⁶	4.39 ⁷	7.10	11.03	17.82	1.81 ⁶	4.76 ⁷	7.53	11.57	19.72	4.92	7.83	11.67	20.33	27.36
16	12	1.62 ⁶	3.60 ⁷	3.10 ⁷	5.41	7.66	10.92	16.66	3.35 ⁷	5.83	8.36	11.64	18.52	5.96	8.51	12.09	19.41	25.30
	16	0.71 ⁶	2.68 ⁶	2.12 ⁶	4.49 ⁷	6.82	10.17	16.00	2.37 ⁶	4.90 ⁷	7.50	10.83	17.83	5.05	7.67	11.29	18.67	24.62
	24		0.83 ³	0.17 ³	2.66 ⁶	5.13 ⁶	8.67 ⁷	14.68	0.41 ³	3.05 ⁶	5.77 ⁶	9.20 ⁷	16.45	3.24 ⁶	6.00 ⁷	9.69	17.18	23.28

20 Psf Lateral Load: Axial Compression Load (kips)																		
Wall Height (ft)	Spacing (in) o.c.	800SG162-(mils)			800SG200-(mils)				800SG250-(mils)					800SG300-(mils)				
		33	43	54	33	43	54	68	97	33	43	54	68	97	43	54	68	97
8	12	3.13	4.95	5.09	7.93	11.49	16.66	25.67	5.41	8.43	12.22	17.67	30.71	8.67	12.58	18.22	31.75	42.92
	16	2.98	4.80	4.92	7.76	11.31	16.48	25.51	5.24	8.25	12.03	17.47	30.53	8.49	12.39	18.03	31.55	42.73
	24	2.70	4.50	4.58	7.40	10.94	16.12	25.18	4.89	7.90	11.66	17.09	30.15	8.14	12.02	17.64	31.14	42.34
9	12	3.01	4.83	4.95	7.79	11.35	16.51	25.54	5.27	8.29	12.07	17.51	30.56	8.53	12.43	18.06	31.59	42.77
	16	2.83	4.64	4.74	7.57	11.12	16.29	25.33	5.05	8.06	11.83	17.27	30.32	8.30	12.19	17.82	31.33	42.52
	24	2.47	4.26	4.31	7.12	10.65	15.84	24.92	4.62	7.61	11.36	16.78	29.84	7.85	11.73	17.34	30.82	42.03
10	12	2.89	4.70	4.80	7.64	11.19	16.35	25.39	5.12	8.13	11.90	17.34	30.39	8.37	12.26	17.89	31.41	42.60
	16	2.66	4.47	4.54	7.36	10.90	16.08	25.14	4.85	7.85	11.61	17.04	30.10	8.09	11.98	17.60	31.09	42.29
	24	2.21	4.00	4.01	6.81	10.33	15.52	24.62	4.31	7.29	11.03	16.44	29.51	7.53	11.40	17.00	30.46	41.69
12	12	2.59	4.39	4.45	7.27	10.81	15.99	25.05	4.76	7.76	11.52	16.94	30.00	8.00	11.88	17.50	30.99	42.20
	16	2.27	4.06	4.07	6.87	10.40	15.59	24.68	4.37	7.36	11.10	16.51	29.58	7.60	11.47	17.07	30.54	41.76
	24	1.62	3.39	3.31	6.08	9.57	14.78	23.94	3.60	6.55	10.27	15.65	28.73	6.79	10.64	16.21	29.63	40.90
14	12	2.24	4.03	4.04	6.84	10.36	15.55	24.65	4.34	7.32	11.07	16.48	29.54	7.57	11.43	17.04	29.99	40.62
	16	1.80	3.57	3.52	6.30	9.80	15.01	24.15	3.81	6.77	10.50	15.89	28.96	7.02	10.87	16.45	29.39	40.05
	24	0.93	2.66	2.48	5.22	8.68	13.91	23.13	2.75	5.68	9.36	14.71	27.80	5.92	9.74	15.28	28.17	38.89
16	12	1.84	3.61	3.56	6.34	9.84	15.05	24.19	3.85	6.82	10.55	15.94	27.89	7.06	10.91	16.50	27.94	37.44
	16	1.27	3.02	2.88	5.64	9.11	14.34	23.53	3.16	6.10	9.80	15.17	27.16	6.35	10.18	15.73	27.19	36.74
	24	0.12 ⁶	1.83 ⁷	1.52 ⁷	4.23	7.65	12.91	22.20	1.78 ⁷	4.67	8.32	13.63	25.71	4.91	8.70	14.21	25.68	35.34

30 Psf Lateral Load: Axial Compression Load (kips)																		
Wall Height (ft)	Spacing (in) o.c.	350SG200-(mils)					350SG250-(mils)					350SG350-(mils)		362SG200-(mils)				
		33	43	54	68	97	33	43	54	68	97	68	33	43	54	68	97	
8	12	2.10	3.44	4.81	6.40	10.02	2.34	3.92	5.60	7.45	11.60		8.07	2.21	3.62	5.05	6.79	10.63
	16	1.73 ⁷	3.07	4.45	6.05	9.70	1.96	3.53	5.20	7.07	11.28		7.69	1.85	3.25	4.70	6.44	10.31
	24	0.99 ⁶	2.33 ⁶	3.74	5.36	9.06	1.21 ⁶	2.75 ⁷	4.40	6.31	10.62		6.92	1.11 ⁶	2.51 ⁷	3.99	5.75	9.66
9	12	1.70 ⁷	2.93	4.19	5.65	8.91	1.93	3.40	4.90	6.61	10.39		7.38	1.82 ⁷	3.11	4.46	6.05	9.54
	16	1.26 ⁶	2.49 ⁷	3.78	5.25	8.54	1.48 ⁶	2.93	4.43	6.17	10.01		6.92	1.38 ⁶	2.68 ⁷	4.04	5.65	9.16
	24	0.38 ³	1.62 ⁶	2.94 ⁶	4.44 ⁷	7.80	0.58 ⁶	2.00 ⁶	3.49 ⁷	5.28	9.25		6.00	0.50 ³	1.80 ⁶	3.20 ⁶	4.83 ⁷	8.41
10	12	1.30 ⁶	2.41 ⁷	3.56	4.90	7.79	1.51 ⁶	2.87 ⁷	4.19	5.76	9.15		6.71	1.42 ⁶	2.60 ⁷	3.85	5.30	8.41
	16	0.79 ³	1.92 ⁶	3.09 ⁶	4.44 ⁷	7.37	0.99 ⁶	2.33 ⁶	3.66 ⁷	5.26	8.73		6.17	0.91 ⁶	2.10 ⁶	3.37 ⁷	4.83	7.99
	24		0.93 ³	2.15 ⁶	3.53 ⁶	6.55 ⁷		1.25 ³	2.59 ⁶	4.26 ⁶	7.89		5.09 ⁷		1.10 ³	2.41 ⁶	3.91 ⁶	7.15 ⁷
12	12	0.53 ³	1.44 ³	2.37 ⁶	3.45 ⁶	5.71	0.70 ³	1.79 ⁶	2.83 ⁶	4.12 ⁷	6.83		5.19	0.63 ³	1.61 ⁶	2.64 ⁶	3.81 ⁶	6.26
	16		0.86 ³	1.82 ³	2.92 ⁶	5.24 ⁶	0.07 ²	1.15 ³	2.21 ⁶	3.54 ⁶	6.34 ⁷		4.52 ⁷	0.01 ²	1.02 ³	2.07 ³	3.27 ⁶	5.77 ⁷
	24			0.73 ²	1.87 ³	4.31 ⁶			0.97 ³	2.38 ³	5.38 ⁶		3.17 ⁶			0.93 ²	2.18 ³	4.81 ⁶
14	12		0.66 ²	1.43 ³	2.31 ³	4.14 ⁶	0.01 ²	0.89 ³	1.74 ³	2.81 ⁶	5.04 ⁶		3.75 ⁶		0.79 ³	1.63 ³	2.59 ⁶	4.58 ⁶
	16		0.01 ²	0.83 ²	1.74 ³	3.64 ³		0.18 ²	1.06 ²	2.18 ³	4.52 ⁶		2.98 ⁶		0.13 ²	1.01 ²	2.00 ³	4.05 ⁶
	24				0.59 ²	2.62 ²				0.90 ²	3.47 ³		1.45 ³				0.81 ²	3.01 ³
16	12		0.05 ²	0.72 ²	1.45 ²	2.97 ³		0.20 ²	0.91 ²	1.81 ³	3.70 ⁶		2.49 ³		0.15 ²	0.86 ²	1.67 ³	3.31 ³
	16			0.08 ²	0.84 ²	2.44 ²			0.18 ²	1.14 ²	3.14 ³		1.67 ³			0.20 ²	1.03 ²	2.76 ³
	24					1.36 ²					2.							

Load Bearing Wall Members

Combined Axial & Lateral Load Tables

Refer to Important Table Notes on Page 9

30 Psf Lateral Load: Axial Compression Load (kips)																		
Wall Height (ft)	Spacing (in) o.c.	362SG250-(mils)					362SG350-(mils)			400SG200-(mils)					400SG250-(mils)			
		33	43	54	68	97	68	33	43	54	68	97	33	43	54	68	97	
8	12	2.46	4.10	5.88	7.89	12.29	8.47	2.52	4.11	5.71	7.81	11.79	2.78	4.57	6.46	9.04	13.67	
	16	2.08	3.71	5.48	7.51	11.96	8.09	2.16	3.75	5.36	7.47	11.44	2.41	4.20	6.08	8.66	13.32	
	24	1.34 ⁶	2.94	4.69	6.75	11.30	7.32	1.46 ⁷	3.02	4.66	6.78	10.72	1.69	3.45	5.32	7.90	12.62	
9	12	2.05	3.59	5.21	7.06	11.09	7.75	2.14	3.63	5.16	7.15	10.84	2.39	4.11	5.95	8.28	12.62	
	16	1.60 ⁷	3.13	4.73	6.61	10.71	7.29	1.71 ⁷	3.19	4.74	6.74	10.41	1.95	3.65	5.48	7.82	12.20	
	24	0.71 ⁶	2.20 ⁶	3.79 ⁷	5.72	9.94	6.37	0.85 ⁶	2.33 ⁶	3.90 ⁷	5.91	9.56	1.07 ⁶	2.75 ⁷	4.55	6.91	11.37	
10	12	1.63 ⁶	3.06	4.51	6.21	9.86	7.07	1.75 ⁷	3.13	4.57	6.44	9.82	1.98	3.60	5.34	7.48	11.51	
	16	1.11 ⁶	2.52 ⁶	3.97 ⁷	5.70	9.43	6.53	1.24 ⁶	2.63 ⁷	4.08	5.96	9.34	1.46 ⁶	3.07	4.80	6.95	11.03	
	24	0.07 ³	1.45 ⁶	2.89 ⁶	4.68 ⁶	8.57	5.46	0.24 ³	1.62 ⁶	3.11 ⁶	5.01 ⁷	8.36	0.43 ⁶	2.00 ⁶	3.70 ⁶	5.89	10.07	
12	12	0.82 ³	2.00 ⁶	3.14 ⁶	4.54 ⁷	7.45	5.62	0.96 ⁶	2.13 ⁶	3.39 ⁶	4.96	7.74	1.16 ⁶	2.57 ⁶	3.99 ⁷	5.82	9.22	
	16	0.17 ³	1.34 ³	2.50 ⁶	3.94 ⁶	6.95 ⁷	4.93 ⁷	0.32 ³	1.50 ³	2.78 ⁶	4.37 ⁶	7.15	0.50 ³	1.89 ⁶	3.31 ⁶	5.16 ⁷	8.64	
	24		0.02 ²	1.21 ³	2.73 ³	5.96 ⁶	3.56 ⁶		0.25 ²	1.57 ³	3.20 ⁶	5.96 ⁶		0.53 ³	1.95 ³	3.85 ⁶	7.46 ⁶	
14	12	0.10 ²	1.05 ³	1.97 ³	3.13 ⁶	5.54 ⁶	4.15 ⁶	0.22 ²	1.21 ³	2.27 ⁶	3.53 ⁶	5.76 ⁷	0.38 ³	1.55 ³	2.72 ⁶	4.19 ⁶	7.02	
	16		0.32 ²	1.27 ³	2.47 ³	5.00 ⁶	3.36 ⁶		0.50 ²	1.59 ³	2.88 ³	5.11 ⁶		0.77 ³	1.94 ³	3.46 ⁶	6.37 ⁶	
	24				1.15 ²	3.91 ³	1.77 ³			0.21 ²	1.57 ²	3.79 ³			0.40 ²	2.00 ³	5.06 ⁶	
16	12		0.31 ²	1.08 ²	2.06 ³	4.09 ⁶	2.81 ⁶		0.46 ²	1.36 ³	2.39 ³	4.19 ⁶		0.69 ²	1.66 ³	2.88 ⁶	5.23 ⁶	
	16			0.33 ²	1.36 ²	3.52 ³	1.96 ³			0.62 ²	1.70 ²	3.50 ³			0.83 ²	2.10 ³	4.54 ⁶	
	24					2.37 ²	0.25 ²				0.30 ²	2.10 ²				0.54 ²	3.15 ³	

30 Psf Lateral Load: Axial Compression Load (kips)																					
Wall Height (ft)	Spacing (in) o.c.	400SG350-(mils)			550SG162-(mils)		550SG200-(mils)					550SG250-(mils)					550SG300-(mils)				
		68	97	118	33	43	33	43	54	68	97	33	43	54	68	97	43	54	68	97	118
8	12	9.48	16.12	21.07	3.38	4.86	5.10	7.61	9.97	13.45	19.50	5.20	8.35	11.68	15.90	25.54	8.37	12.16	16.25	25.91	35.85
	16	9.11	15.75	20.71	2.99	4.51	4.67	7.20	9.59	13.11	19.20	4.79	7.92	11.26	15.50	25.17	7.96	11.74	15.85	25.52	35.47
	24	8.36	14.99	19.98	2.22	3.81	3.83	6.38	8.84	12.43	18.60	3.97	7.07	10.42	14.69	24.44	7.14	10.90	15.06	24.76	34.71
9	12	8.83	15.09	19.60	3.07	4.58	4.76	7.28	9.67	13.18	19.26	4.88	8.01	11.35	15.58	25.25	8.04	11.55	15.56	24.98	34.39
	16	8.38	14.63	19.17	2.58	4.14	4.23	6.76	9.19	12.75	18.88	4.36	7.47	10.82	15.07	24.78	7.52	11.04	15.07	24.51	33.92
	24	7.47	13.73	18.30	1.60	3.25	3.16	5.73	8.23	11.89	18.11	3.32	6.40	9.76	14.04	23.85	6.49	10.00	14.09	23.56	32.99
10	12	8.14	14.02	18.05	2.72	4.27	4.38	6.92	9.33	12.87	18.99	4.51	7.63	10.68	14.86	24.30	7.68	10.88	14.78	23.94	32.71
	16	7.60	13.49	17.55	2.12	3.72	3.72	6.28	8.74	12.34	18.52	3.87	6.97	10.04	14.24	23.73	7.04	10.26	14.19	23.37	32.16
	24	6.53	12.43	16.55	0.91 ⁶	2.63	2.40 ⁷	5.01	7.56	11.28	17.58	2.59	5.64	8.77	13.00	22.61	5.76	9.02	13.02	22.24	31.05
12	12	6.76	11.77	14.84	1.93 ⁷	3.54	3.51	6.08	8.55	12.17	18.37	3.66	6.55	9.15	13.12	21.32	6.63	9.38	13.06	21.65	28.96
	16	6.06	11.09	14.23	1.06 ⁶	2.76 ⁷	2.56 ⁷	5.16	7.70	11.41	17.69	2.74 ⁷	5.63	8.30	12.29	20.59	5.74	8.55	12.27	20.89	28.23
	24	4.65 ⁶	9.74	13.00		1.18 ⁶	0.66 ⁶	3.32 ⁶	6.00 ⁷	9.88	16.33	0.89 ⁶	3.77 ⁶	6.59	10.62	19.12	3.94 ⁷	6.89	10.69	19.36	26.79
14	12	5.26 ⁷	9.13	11.69	0.98 ⁶	2.69 ⁶	2.34 ⁶	4.70 ⁷	7.02	10.41	16.28	2.58 ⁶	5.07	7.57	11.02	18.11	5.20	7.78	11.31	18.85	24.92
	16	4.42 ⁶	8.37 ⁷	11.00		1.62 ⁶	1.12 ⁶	3.55 ⁶	5.96 ⁷	9.46	15.43	1.36 ⁶	3.92 ⁶	6.51 ⁷	10.00	17.23	4.08 ⁷	6.74	10.32	17.91	24.05
	24	2.74 ³	6.85 ⁶	9.61 ⁶				1.24 ³	3.83 ⁶	7.55 ⁶	13.72 ⁷		1.61 ⁶	4.37 ⁶	7.95 ⁶	15.47	1.84 ⁶	4.66 ⁶	8.33 ⁷	16.03	22.32
16	12	3.85 ⁶	6.91 ⁷	9.03		1.70 ³	1.08 ³	3.19 ⁶	5.27 ⁶	8.21 ⁷	13.25	1.30 ⁶	3.61 ⁶	6.01 ⁷	8.84	14.93	3.78 ⁶	6.16 ⁷	9.45	15.82	20.88
	16	2.91 ³	6.09 ⁶	8.30 ⁶		0.30 ³		1.87 ³	4.05 ⁶	7.14 ⁶	12.29 ⁷		2.25 ⁶	4.74 ⁶	7.66 ⁶	13.94	2.45 ⁶	4.93 ⁶	8.27 ⁷	14.74	19.90
	24	1.03 ²	4.46 ³	6.82 ⁶				1.63 ³	4.99 ³	10.38 ⁶				2.20 ³	5.32 ⁶	11.95 ⁶		2.48 ³	5.91 ⁶	12.57 ⁷	17.94

30 Psf Lateral Load: Axial Compression Load (kips)																		
Wall Height (ft)	Spacing (in) o.c.	600SG162-(mils)			600SG200-(mils)					600SG250-(mils)					600SG300-(mils)			
		33	43	54	33	43	54	68	97	33	43	54	68	97	43	54	68	97
8	12	3.32	5.34	5.11	8.16	10.68	14.36	20.81	5.26	8.40	12.27	16.81	26.88	8.45	12.38	17.44	27.66	38.06
	16	2.98	4.99	4.73	7.76	10.31	14.03	20.53	4.88	8.01	11.87	16.42	26.53	8.07	11.99	17.05	27.29	37.70
	24	2.30	4.30	3.97	6.98	9.58	13.37	19.95	4.14	7.24	11.07	15.64	25.83	7.32	11.22	16.28	26.54	36.98
9	12	3.05	5.06	4.81	7.84	10.39	14.10	20.58	4.96	8.09	11.95	16.50	26.60	8.15	12.07	16.80	26.81	37.03
	16	2.62	4.62	4.33	7.35	9.93	13.68	20.22	4.49	7.60	11.45	16.01	26.16	7.67	11.58	16.32	26.35	36.59
	24	1.76	3.74	3.37	6.35	9.00	12.85	19.49	3.54	6.62	10.44	15.02	25.27	6.73	10.61	15.37	25.43	35.69
10	12	2.75	4.75	4.47	7.49	10.06	13.80	20.33	4.63	7.74	11.60	16.13	26.29	7.82	11.73	16.08	25.85	35.53
	16	2.21	4.21	3.88	6.88	9.49	13.29	19.88	4.04	7.14	10.97	15.53	25.74	7.23	11.13	15.50	25.30	35.00
	24	1.15 ⁷	3.12	2.69	5.65	8.35	12.27	18.98	2.88	5.94	9.73	14.31	24.64	6.06	9.92	14.35	24.19	33.92
12	12	2.04	4.03	3.69	6.68	9.31	13.13	19.73	3.86	6.95	10.22	14.47	23.69	7.04	10.46	14.42	23.67	32.07
	16	1.28 ⁷	3.25	2.83	5.79	8.49	12.39	19.09	3.02	6.08	9.37	13.64	22.96	6.20	9.63	13.64	22.91	31.36
	24		1.69 ⁶	1.12 ⁶	4.02 ⁷	6.84	10.92	17.79	1.34 ⁶	4.35	7.68	11.99	21.49	4.52	7.97	12.08	21.41	29.93
14	12	1.21 ⁶	3.19 ⁷	2.76 ⁷	5.57	8.19	12.01	18.68	2.95 ⁷	5.93	8.60	12.61	20.62	6.05	8.88	12.66	21.28	28.24
	16	0.17 ⁶	2.13 ⁶	1.60 ⁶	4.39 ⁷	7.10	11.03	17.82	1.81 ⁶	4.76 ⁷	7.53	11.57	19.72	4.92	7.83	11.6		

Load Bearing Wall Members

Combined Axial & Lateral Load Tables

Refer to Important Table Notes on Page 9

30 Psf Lateral Load: Axial Compression Load (kips)																		
Wall Height (ft)	Spacing (in) o.c.	800SG162-(mils)			800SG200-(mils)			800SG250-(mils)					800SG300-(mils)					
		33	43	43	33	43	54	68	97	33	43	54	68	97	43	54	68	97
8	12	2.91	4.73	4.83	7.67	11.22	16.39	25.43	5.15	8.16	11.94	17.38	30.43	8.40	12.30	17.93	31.44	42.63
	16	2.70	4.50	4.58	7.40	10.94	16.12	25.18	4.89	7.90	11.66	17.09	30.15	8.14	12.02	17.64	31.14	42.34
	24	2.27	4.06	4.07	6.87	10.40	15.59	24.68	4.37	7.36	11.10	16.51	29.58	7.60	11.47	17.07	30.54	41.76
9	12	2.74	4.55	4.63	7.46	11.00	16.18	25.23	4.94	7.95	11.72	17.15	30.20	8.19	12.08	17.70	31.20	42.40
	16	2.47	4.26	4.31	7.12	10.65	15.84	24.92	4.62	7.61	11.36	16.78	29.84	7.85	11.73	17.34	30.82	42.03
	24	1.93	3.70	3.66	6.45	9.96	15.16	24.29	3.96	6.93	10.66	16.05	29.13	7.17	11.03	16.61	30.05	41.30
10	12	2.55	4.35	4.40	7.22	10.76	15.94	25.01	4.71	7.71	11.47	16.89	29.95	7.95	11.83	17.45	30.93	42.14
	16	2.21	4.00	4.01	6.81	10.33	15.52	24.62	4.31	7.29	11.03	16.44	29.51	7.53	11.40	17.00	30.46	41.69
	24	1.54	3.30	3.21	5.98	9.47	14.68	23.84	3.50	6.45	10.16	15.54	28.62	6.69	10.53	16.10	29.52	40.79
12	12	2.11	3.89	3.88	6.68	10.19	15.38	24.50	4.18	7.16	10.89	16.30	29.36	7.40	11.26	16.86	30.31	41.54
	16	1.62	3.39	3.31	6.08	9.57	14.78	23.94	3.60	6.55	10.27	15.65	28.73	6.79	10.64	16.21	29.63	40.90
	24	0.66	2.38	2.16	4.89	8.33	13.58	22.82	2.43	5.34	9.02	14.35	27.45	5.59	9.39	14.92	28.27	39.59
14	12	1.58	3.35	3.26	6.03	9.52	14.73	23.89	3.55	6.50	10.22	15.59	28.67	6.74	10.58	16.16	29.08	39.76
	16	0.93	2.66	2.48	5.22	8.68	13.91	23.13	2.75	5.68	9.36	14.71	27.80	5.92	9.74	15.28	28.17	38.89
	24		1.30 ⁷	0.92 ⁷	3.60	6.99	12.28	21.61	1.16 ⁷	4.03	7.66	12.94	26.06	4.28	8.04	13.53	26.35	37.17
16	12	0.98 ⁷	2.72	2.54	5.29	8.74	13.98	23.20	2.82	5.74	9.43	14.78	26.80	5.99	9.81	15.35	26.81	36.39
	16	0.12 ⁶	1.83 ⁷	1.52 ⁷	4.23	7.65	12.91	22.20	1.78 ⁷	4.67	8.32	13.63	25.71	4.91	8.70	14.21	25.68	35.34
	24		0.04 ⁶		2.10 ⁶	5.45 ⁷	10.77	20.22		2.51 ⁶	6.10	11.32	23.52	2.77 ⁷	6.48	11.91	23.42	33.23

40 Psf Lateral Load: Axial Compression Load (kips)																		
Wall Height (ft)	Spacing (in) o.c.	350SG200-(mils)					350SG250-(mils)					350SG350-(mils)		362SG200-(mils)				
		33	43	54	68	97	33	43	54	68	97	68	33	43	54	68	97	
8	12	1.73 ⁷	3.07	4.45	6.05	9.70	1.96	3.53	5.20	7.07	11.28	7.69	1.85	3.25	4.70	6.44	10.31	
	16	1.24 ⁶	2.58 ⁷	3.98	5.59	9.27	1.46 ⁷	3.01	4.66	6.57	10.84	7.18	1.36 ⁶	2.76	4.22	5.98	9.88	
	24	0.25 ³	1.59 ⁶	3.02 ⁶	4.67 ⁷	8.41	0.46 ⁶	1.97 ⁶	3.60 ⁷	5.56	9.97	6.16	0.38 ⁶	1.78 ⁶	3.27 ⁶	5.05	9.02	
9	12	1.26 ⁶	2.49 ⁷	3.78	5.25	8.54	1.48 ⁶	2.93	4.43	6.17	10.01	6.92	1.38 ⁶	2.68 ⁷	4.04	5.65	9.16	
	16	0.67 ⁶	1.91 ⁶	3.22 ⁶	4.71 ⁷	8.04	0.88 ⁶	2.31 ⁶	3.81 ⁷	5.58	9.50	6.31	0.79 ⁶	2.10 ⁶	3.48 ⁷	5.10	8.66	
	24		0.75 ³	2.10 ⁶	3.63 ⁶	7.06 ⁷		1.07 ⁶	2.55 ⁶	4.40 ⁶	8.50	5.08		0.93 ³	2.35 ⁶	4.01 ⁶	7.66 ⁷	
10	12	0.79 ³	1.92 ⁶	3.09 ⁶	4.44 ⁷	7.37	0.99 ⁶	2.33 ⁶	3.66 ⁷	5.26	8.73	6.17	0.91 ⁶	2.10 ⁶	3.37 ⁷	4.83	7.99	
	16	0.11 ³	1.26 ³	2.46 ⁶	3.83 ⁶	6.82 ⁷	0.30 ³	1.61 ⁶	2.95 ⁶	4.60 ⁷	8.17	5.45	0.23 ³	1.44 ⁶	2.73 ⁶	4.22 ⁶	7.43	
	24			1.20 ³	2.62 ³	5.72 ⁶		0.18 ³	1.53 ³	3.27 ⁶	7.04 ⁶	4.02 ⁶		0.11 ³	1.45 ³	2.98 ⁶	6.31 ⁶	
12	12		0.86 ³	1.82 ³	2.92 ⁶	5.24 ⁶	0.07 ²	1.15 ³	2.21 ⁶	3.54 ⁶	6.34 ⁷	4.52 ⁷	0.01 ²	1.02 ³	2.07 ³	3.27 ⁶	5.77 ⁷	
	16		0.08 ²	1.09 ³	2.22 ³	4.62 ⁶		0.29 ²	1.38 ³	2.77 ³	5.70 ⁶	3.62 ⁶		0.22 ²	1.31 ³	2.55 ³	5.13 ⁶	
	24				0.82 ²	3.37 ³				1.22 ²	4.41 ³	1.83 ³				1.10 ²	3.84 ³	
14	12		0.01 ²	0.83 ²	1.74 ³	3.64 ³		0.18 ²	1.06 ²	2.18 ³	4.52 ⁶	2.98 ⁶		0.13 ²	1.01 ²	2.00 ³	4.05 ⁶	
	16			0.03 ²	0.97 ²	2.96 ³			0.15 ²	1.33 ²	3.82 ³	1.96 ³			0.17 ²	1.21 ²	3.35 ³	
	24					1.61 ²					2.41 ²						1.96 ²	
16	12			0.08 ²	0.84 ²	2.44 ²			0.18 ²	1.14 ²	3.14 ³	1.67 ³			0.20 ²	1.03 ²	2.76 ³	
	16				0.02 ²	1.72 ²				0.23 ²	2.40 ²	0.58 ²				0.19 ²	2.02 ²	
	24					0.29 ¹					0.91 ²						0.55 ²	

40 Psf Lateral Load: Axial Compression Load (kips)																		
Wall Height (ft)	Spacing (in) o.c.	362SG250-(mils)					362SG350-(mils)		400SG200-(mils)					400SG250-(mils)				
		33	43	54	68	97	68	33	43	54	68	97	33	43	54	68	97	
8	12	2.08	3.71	5.48	7.51	11.96	8.09	2.16	3.75	5.36	7.47	11.44	2.41	4.20	6.08	8.66	13.32	
	16	1.59 ⁷	3.20	4.95	7.00	11.52	7.58	1.69 ⁷	3.27	4.89	7.01	10.96	1.93	3.70	5.57	8.15	12.86	
	24	0.60 ⁶	2.16 ⁶	3.89 ⁷	5.99	10.65	6.56	0.75 ⁶	2.30 ⁷	3.96	6.10	10.01	0.97 ⁶	2.70 ⁷	4.56	7.14	11.93	
9	12	1.60 ⁷	3.13	4.73	6.61	10.71	7.29	1.71 ⁷	3.19	4.74	6.74	10.41	1.95	3.65	5.48	7.82	12.20	
	16	1.01 ⁶	2.51 ⁶	4.10	6.01	10.20	6.68	1.14 ⁶	2.62 ⁷	4.18	6.19	9.85	1.36 ⁶	3.05	4.86	7.21	11.65	
	24		1.27 ⁶	2.84 ⁶	4.82 ⁷	9.17	5.46		1.46 ⁶	3.06 ⁶	5.09 ⁷	8.71	0.20 ⁶	1.84 ⁶	3.62 ⁷	6.00	10.54	
10	12	1.11 ⁶	2.52 ⁶	3.97 ⁷	5.70	9.43	6.53	1.24 ⁶	2.63 ⁷	4.08	5.96	9.34	1.46 ⁶	3.07	4.80	6.95	11.03	
	16	0.42 ³	1.81 ⁶	3.25 ⁶	5.02 ⁷	8.85	5.81	0.57 ⁶	1.95 ⁶	3.43 ⁶	5.33 ⁷	8.68	0.78 ⁶	2.36 ⁶	4.07 ⁷	6.24	10.39	
	24		0.37 ³	1.81 ³	3.66 ⁶	7.70 ⁷	4.38 ⁶		0.61 ³	2.13 ⁶	4.05 ⁶	7.38 ⁷		0.94 ⁶	2.61 ⁶	4.83 ⁶	9.11	
12	12	0.17 ³	1.34 ³	2.50 ⁶	3.94 ⁶	6.95 ⁷	4.93 ⁷	0.32 ³	1.50 ³	2.78 ⁶	4.37 ⁶	7.15	0.50 ³	1.89 ⁶	3.31 ⁶	5.16 ⁷	8.64	
	16		0.46 ³	1.64 ³	3.13 ⁶	6.29 ⁶	4.02 ⁶		0.67 ³	1.97 ³	3.59 ⁶	6.36 ⁶		0.98 ³	2.40 ⁶	4.29 ⁶	7.86 ⁷	
	24				1.53 ³	4.96 ³	2.19 ³			0.36 ²	2.02 ³	4.78 ⁶			0.59 ³	2.54 ³	6.29 ⁶	
14	12		0.32 ²	1.27 ³	2.47 ³	5.00 ⁶	3.36 ⁶		0.50 ²	1.59 ³	2.88 ³	5.11 ⁶		0.77 ³	1.94 ³	3.46 ⁶	6.37 ⁶	
	16			0.32 ²	1.59 ³	4.27 ³	2.30 ³			0.67 ²	2.01 ³	4.23 ³			0.91 ³	2.49 ³	5.50 ⁶	
	24					2.83 ²	0.18 ²				0.26 ²	2.48 ²				0.54 ²	3.76 ³	
16	12			0.33 ²	1.36 ²	3.52 ³	1.96 ³			0.62 ²	1.70 ²	3.50 ³			0.83 ²	2.10 ³	4.54 ⁶	
	16				0.42 ²	2.75 ²	0.82 ²				0.77 ²	2.57 ³				1.06 ²	3.61 ³	
	24					1.21 ²						0.71 ²					1.76 ²	

1 = Deflection Exceeds L/120
2 = Deflection Exceeds L/240

Refer to Important Table Notes on Page 9

40 Psf Lateral Load: Axial Compression Load (kips)																					
Wall Height (ft)	Spacing (in) o.c.	400SG350-(mils)			550SG162-(mils)		550SG200-(mils)					550SG250-(mils)					550SG300-(mils)				
		68	97	118	33	43	33	43	54	68	97	33	43	54	68	97	43	54	68	97	118
8	12	9.11	15.75	20.71	2.99	4.51	4.67	7.20	9.59	13.11	19.20	4.79	7.92	11.26	15.50	25.17	7.96	11.74	15.85	25.52	35.47
	16	8.61	15.24	20.23	2.47	4.04	4.11	6.65	9.09	12.66	18.80	4.25	7.35	10.70	14.96	24.68	7.41	11.18	15.32	25.01	34.96
	24	7.61	14.24	19.26	1.44	3.11	2.98	5.57	8.08	11.75	17.99	3.15	6.22	9.59	13.87	23.70	6.32	10.07	14.27	23.99	33.94
9	12	8.38	14.63	19.17	2.58	4.14	4.23	6.76	9.19	12.75	18.88	4.36	7.47	10.82	15.07	24.78	7.52	11.04	15.07	24.51	33.92
	16	7.77	14.03	18.59	1.93	3.54	3.51	6.08	8.55	12.17	18.37	3.66	6.75	10.11	14.38	24.16	6.83	10.35	14.41	23.87	33.30
	24	6.56	12.82	17.43	0.62 ⁶	2.36	2.09	4.70	7.28	11.03	17.35	2.28	5.32	8.70	13.01	22.91	5.45	8.97	13.11	22.61	32.06
10	12	7.60	13.49	17.55	2.12	3.72	3.72	6.28	8.74	12.34	18.52	3.87	6.97	10.04	14.24	23.73	7.04	10.26	14.19	23.37	32.16
	16	6.89	12.78	16.88	1.31 ⁷	2.99	2.84	5.43	7.95	11.64	17.89	3.01	6.08	9.20	13.41	22.98	6.18	9.43	13.41	22.62	31.43
	24	5.45 ⁷	11.37	15.55		1.53 ⁶	1.08 ⁶	3.73 ⁷	6.38	10.22	16.63	1.30 ⁷	4.31	7.50	11.76	21.48	4.48	7.78	11.84	21.10	29.95
12	12	6.06	11.09	14.23	1.06 ⁶	2.76 ⁷	2.56 ⁷	5.16	7.70	11.41	17.69	2.74 ⁷	5.63	8.30	12.29	20.59	5.74	8.55	12.27	20.89	28.23
	16	5.12 ⁷	10.19	13.41		1.71 ⁶	1.30 ⁶	3.94 ⁶	6.57	10.39	16.78	1.51 ⁶	4.39 ⁷	7.16	11.17	19.61	4.54	7.44	11.22	19.87	27.27
	24	3.24 ⁶	8.39 ⁶	11.76 ⁷				1.49 ⁶	4.30 ⁶	8.36 ⁷	14.97		1.92 ⁶	4.89 ⁶	8.95 ⁷	17.65	2.16 ⁶	5.22 ⁷	9.12	17.83	25.35
14	12	4.42 ⁶	8.37 ⁷	11.00		1.62 ⁶	1.12 ⁶	3.55 ⁶	5.96 ⁷	9.46	15.43	1.36 ⁶	3.92 ⁶	6.51 ⁷	10.00	17.23	4.08 ⁷	6.74	10.32	17.91	24.05
	16	3.30 ⁶	7.35 ⁶	10.08 ⁷		0.19 ³		2.01 ⁶	4.54 ⁶	8.19 ⁶	14.29		2.38 ⁶	5.08 ⁶	8.63 ⁷	16.06	2.59 ⁶	5.35 ⁶	8.99	16.65	22.89
	24	1.06 ³	5.32 ³	8.23 ⁶					1.69 ³	5.65 ⁶	12.00 ⁶			2.24 ³	5.90 ⁶	13.71 ⁷		2.58 ⁶	6.34 ⁶	14.14 ⁷	20.58
16	12	2.91 ³	6.09 ⁶	8.30 ⁶		0.30 ³		1.87 ³	4.05 ⁶	7.14 ⁶	12.29 ⁷		2.25 ⁶	4.74 ⁶	7.66 ⁶	13.94	2.45 ⁶	4.93 ⁶	8.27 ⁷	14.74	19.90
	16	1.65 ³	5.01 ⁶	7.31 ⁶				0.11 ³	2.44 ³	5.71 ⁶	11.02 ⁶		0.45 ³	3.05 ³	6.10 ⁶	12.61 ⁷	0.69 ³	3.30 ⁶	6.70 ⁶	13.29 ⁷	18.59
	24		2.83 ³	5.34 ³						2.85 ³	8.47 ³				2.97 ³	9.97 ⁶		0.03 ³	3.55 ³	10.41 ⁶	15.98 ⁶

40 Psf Lateral Load: Axial Compression Load (kips)																				
Wall Height (ft)	Spacing (in) o.c.	600SG162-(mils)		600SG200-(mils)					600SG250-(mils)					600SG300-(mils)						
		33	43	33	43	54	68	97	33	43	54	68	97	43	54	68	97	118		
8	12	2.98	4.99	4.73	7.76	10.31	14.03	20.53	4.88	8.01	11.87	16.42	26.53	8.07	11.99	17.05	27.29	37.70		
	16	2.53	4.53	4.23	7.24	9.83	13.59	20.14	4.39	7.50	11.34	15.90	26.06	7.57	11.48	16.54	26.79	37.22		
	24	1.62	3.60	3.21	6.19	8.85	12.72	19.37	3.39	6.47	10.28	14.87	25.13	6.58	10.45	15.51	25.80	36.25		
9	12	2.62	4.62	4.33	7.35	9.93	13.68	20.22	4.49	7.60	11.45	16.01	26.16	7.67	11.58	16.32	26.35	36.59		
	16	2.04	4.03	3.69	6.68	9.31	13.13	19.73	3.86	6.95	10.78	15.35	25.57	7.04	10.93	15.69	25.74	35.99		
	24	0.89 ⁷	2.86	2.41	5.35	8.08	12.03	18.76	2.60	5.65	9.44	14.04	24.38	5.78	9.63	14.41	24.52	34.79		
10	12	2.21	4.21	3.88	6.88	9.49	13.29	19.88	4.04	7.14	10.97	15.53	25.74	7.23	11.13	15.50	25.30	35.00		
	16	1.50	3.49	3.09	6.06	8.73	12.61	19.28	3.27	6.34	10.15	14.72	25.01	6.45	10.32	14.74	24.56	34.28		
	24	0.08 ⁶	2.04 ⁷	1.50 ⁷	4.42	7.21	11.25	18.08	1.72	4.73	8.49	13.10	23.55	4.89	8.72	13.20	23.08	32.85		
12	12	1.28 ⁷	3.25	2.83	5.79	8.49	12.39	19.09	3.02	6.08	9.37	13.64	22.96	6.20	9.63	13.64	22.91	31.36		
	16	0.25 ⁶	2.21 ⁶	1.69 ⁶	4.61	7.39	11.41	18.22	1.90 ⁷	4.92	8.24	12.54	21.98	5.08	8.52	12.60	21.91	30.41		
	24		0.13 ⁶		2.25 ⁶	5.20 ⁶	9.45	16.50		2.61 ⁶	5.98 ⁷	10.35	20.03	2.83 ⁷	6.31	10.51	19.91	28.51		
14	12	0.17 ⁶	2.13 ⁶	1.60 ⁶	4.39 ⁷	7.10	11.03	17.82	1.81 ⁶	4.76 ⁷	7.53	11.57	19.72	4.92	7.83	11.67	20.33	27.36		
	16		0.71 ⁶	0.05 ³	2.83 ⁶	5.65 ⁶	9.73 ⁷	16.67	0.29 ⁶	3.21 ⁶	6.11 ⁷	10.18	18.53	3.41 ⁶	6.43 ⁷	10.35	19.06	26.20		
	24					2.74 ⁶	7.13 ⁶	14.36 ⁷		0.10 ³	3.27 ⁶	7.40 ⁶	16.13	0.39 ⁶	3.64 ⁶	7.70 ⁶	16.51	23.87		
16	12		0.83 ³	0.17 ³	2.66 ⁶	5.13 ⁶	8.67 ⁷	14.68	0.41 ³	3.05 ⁶	5.77 ⁶	9.20 ⁷	16.45	3.24 ⁶	6.00 ⁷	9.69	17.18	23.28		
	16				0.82 ³	3.45 ⁶	7.17 ⁶	13.36 ⁷		1.20 ³	4.05 ⁶	7.58 ⁶	15.06	1.43 ⁶	4.32 ⁶	8.09 ⁷	15.69	21.93		
	24					0.07 ³	4.18 ³	10.72 ⁶			0.61 ³	4.34 ³	12.30 ⁶		0.98 ³	4.88 ⁶	12.72 ⁶	19.24 ⁷		

40 Psf Lateral Load: Axial Compression Load (kips)																				
Wall Height (ft)	Spacing (in) o.c.	800SG162-(mils)		800SG200-(mils)					800SG250-(mils)					800SG300-(mils)						
		33	43	33	43	54	68	97	33	43	54	68	97	43	54	68	97	118		
8	12	2.70	4.50	4.58	7.40	10.94	16.12	25.18	4.89	7.90	11.66	17.09	30.15	8.14	12.02	17.64	31.14	42.34		
	16	2.41	4.20	4.24	7.05	10.58	15.76	24.85	4.55	7.54	11.29	16.70	29.77	7.78	11.65	17.26	30.74	41.96		
	24	1.84	3.61	3.56	6.34	9.84	15.05	24.19	3.85	6.82	10.55	15.94	29.01	7.06	10.91	16.50	29.93	41.18		
9	12	2.47	4.26	4.31	7.12	10.65	15.84	24.92	4.62	7.61	11.36	16.78	29.84	7.85	11.73	17.34	30.82	42.03		
	16	2.11	3.89	3.88	6.68	10.19	15.38	24.50	4.18	7.16	10.89	16.30	29.36	7.40	11.26	16.86	30.31	41.54		
	24	1.38	3.14	3.02	5.78	9.26	14.48	23.66	3.30	6.25	9.96	15.32	28.41	6.49	10.32	15.89	29.29	40.57		
10	12	2.21	4.00	4.01	6.81	10.33	15.52	24.62	4.31	7.29	11.03	16.44	29.51	7.53	11.40	17.00	30.46	41.69		
	16	1.77	3.54	3.48	6.26	9.75	14.96	24.10	3.77	6.73	10.45	15.84	28.91	6.97	10.82	16.40	29.83	41.09		
	24	0.87	2.61	2.41	5.15	8.61	13.85	23.07	2.69	5.61	9.30	14.64	27.73	5.85	9.67	15.21	28.57	39.88		
12	12	1.62	3.39	3.31	6.08	9.57	14.78	23.94	3.60	6.55	10.27	15.65	28.73	6.79	10.64	16.21	29.63	40.90		
	16	0.98	2.72	2.54	5.29	8.74	13.98	23.20	2.82	5.74	9.43	14.78	27.88	5.99	9.81	15.35	28.72	40.03		
	24		1.38	1.01	3.70	7.10	12.38	21.71	1.26	4.13	7.76	13.05	26.17	4.38	8.14	13.63	26.91	38.29		
14	12	0.93	2.66	2.48	5.22	8.68	13.91	23.13	2.75	5.68	9.36	14.71	27.80	5.92	9.74	15.28	28.17	38.89		
	16	0.05 ⁶	1.75	1.44 ⁷	4.14	7.55	12.82	22.12	1.69	4.58	8.23	13.53	26.65	4.82	8.60	14.11	26.95	37.75		
	24				1.97 ⁶	5.31	10.64	20.09		2.38 ⁷	5.96	11.18	24.33	2.63	6.34	11.77	24.53	35.44		
16	12	0.12 ⁶	1.83 ⁷	1.52 ⁷	4.23	7.65	12.91	22.20	1.78 ⁷	4.67	8.32	13.63	25.71	4.91	8.70	14.21	25.68	35.34		
	16		0.64 ⁶	0.17 ⁶	2.81 ⁶	6.18	11.49	20.88	0.40 ⁶	3.23 ⁷	6.84	12.09	24.25	3.48	7.22	12.68	24.18	33.93		
	24					3.25 ⁶	8.63 ⁷	18.24		0.36 ⁶	3.87 ⁶	9.01 ⁷	21.34	0.62 ⁶	4.26 ⁷	9.62	21.16	31.13		

1 = Deflection Exceeds L/120
2 = Deflection Exceeds L/240

3 = Deflection Exceeds L/360
6 = Deflection Exceeds L/600

7 = Deflection Exceeds L/720
If not noted, deflection is less than L/720

Load Bearing Wall Members SigmaStud® STC Ratings and UL Assemblies

Fire Ratings

SigmaStud® projects have revealed that a proprietary shaped load-bearing member does not affect the fire rating of a wall versus using standard (S) section studs. The general requirements of steel studs in a fire-rated load bearing wall includes that the studs shall be designed in accordance with the current edition of the *AISI Specification for the Design of Cold-Formed Steel Structural Members*. Studs shall be corrosion-protected, have a minimum stud size of 3.5 inches, minimum thickness of 33 mil (20 ga), and maximum spacing between studs shall not exceed 16 or 24 inches.

UL's Fire Resistance Ratings vary from 45 minutes to 4 hours. The full report for each Fire Resistance Rating can be found on UL's website (www.ul.com). To obtain the report, click on Online Certifications Directory under Tools at the bottom of the UL homepage. Search by UL File Number. Click on the file link to view report. For technical assistance, please contact UL directly at 1-877-ULHELPS.

A complete listing of all UL Fire Resistance Ratings for use with cold-formed steel studs can be obtained through UL; we have simply attempted to outline the more commonly-used ratings below.

Load Bearing Fire Rated Details

- U404 - LOADBEARING (1 or 2 hr) - Interior Wall
- U407 - LOADBEARING (1 hr) - Interior Wall
- U418 - LOADBEARING (45 min - 2 hr) - Exterior Wall
- U423 - LOADBEARING (45min - 2 hr) - Interior Wall
- U424 - LOADBEARING (45 min - 2 hr) - Exterior Wall
- U425 - LOADBEARING (45 min - 2 hr) - Exterior Wall with detail for Interior
- U426 - LOADBEARING (3 hr) - Interior Wall
- U432 - LOADBEARING (1 hr) - Interior Wall
- U434 - LOADBEARING (1 hr) - Interior Wall
- U440 - LOADBEARING (1 hr) - Interior Wall
- U460 - LOADBEARING (1 hr) - Interior Wall
- U462 - LOADBEARING (3 hr) - Interior Wall
- U473 - LOADBEARING (1 hr) - Interior Wall
- U477 - LOADBEARING (2 hr) - Interior Wall
- U485 - LOADBEARING (1 hr) - Interior Wall
- U487 - LOADBEARING (1 hr) - Interior Wall
- U490 - LOADBEARING (3 or 4 hr) - Interior Wall
- U530 - LOADBEARING (4 hr) - Interior Wall
- V415 - LOADBEARING (2 hr) - Interior Wall
- V420 - LOADBEARING (2 hr) - Interior Wall
- V432 - LOADBEARING (1 hr) - Exterior Wall
- V434 - LOADBEARING (1 hr) - Interior Wall
- V446 - LOADBEARING (1 or 2 hr) - Interior

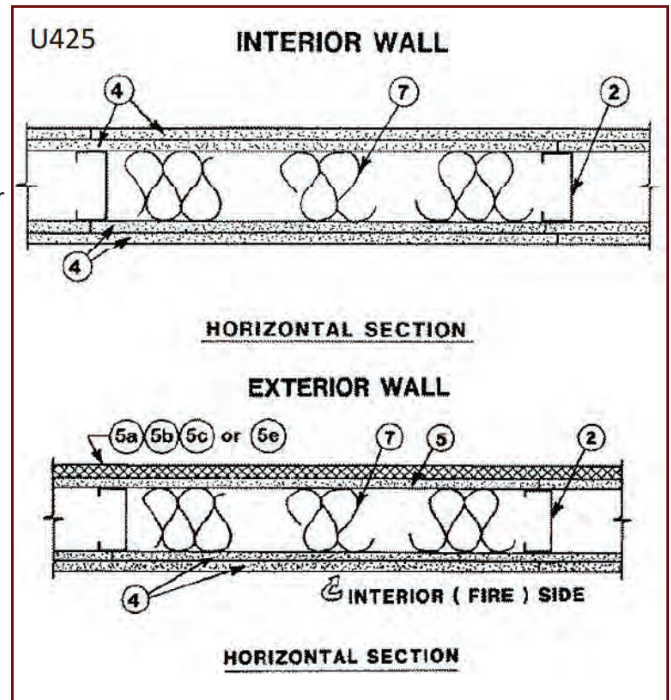

Sound Transmission Ratings

The Gypsum Association maintains details to obtain fire resistance and Sound Transmission Class (STC) Ratings. These details are designated by a Wall and Partition (WP) System. Each detail is outlined in the Gypsum Association Fire Resistance Design Manual. The details mentioned below were obtained from the 20th Edition - June 2012 publication. For additional information on Gypsum Association or to acquire a copy of the Manual, visit www.gypsum.org.

A complete listing of all WP details is not shown; TSN has attempted to list only the generic details unless no generic details were available for a specific application.

Load Bearing WP Details

- WP 1021 - 1 hr (50-54 STC)
 - WP 1024 - 1 hr (50-54 STC)
 - WP 1516 - 2 hr (55-59 STC)
 - WP 1522 - 2 hr (55-59 STC)
 - WP 1635 - 2 hr (45-49 STC)
 - WP 1714 - 2 hr (40-44 STC)
 - WP 1716 - 2 hr (40-44 STC)
 - WP 8006 - 1 hr (NO STC)*
 - WP 8203 - 2 hr (NO STC)*
- * Proprietary System

GA FILE NO. WP 1522	GENERIC	2 HOUR FIRE	55 to 59 STC SOUND
GYPSUM WALLBOARD, STEEL STUDS			
<p>Base layer 5/8" type X gypsum wallboard or gypsum veneer base applied parallel or at right angles to each side of 35/8" steel studs 24" o.c. with 1" Type S drywall screws 24" o.c.</p> <p>Face layer 5/8" type X gypsum wallboard or gypsum veneer base applied parallel or at right angles to each side with 15/8" Type S drywall screws 12" o.c.</p> <p>Joints staggered 24" each layer and side. Sound tested with 31/2" glass fiber friction fit in stud space. (NLB)</p>			
		<p>Thickness: 61/8"</p> <p>Limiting Height: Refer to Section IV</p> <p>Approx. Weight: 12 psf</p> <p>Fire Test: See WP 1548 (WHI-495-0236, 1-30-80)</p> <p>Sound Test: NRCC 818-NV, 2-3-81</p>	

SigmaStud® Punchouts

Each SigmaStud contains punchouts which are 1.5" wide and 4" tall, spaced every 24" o.c. vertically. The first punchout begins 12" o.c. from the end of the stud.

Custom punchout spacing is available upon request. Some restrictions apply.

Reinforcing Non-Standard Holes in SigmaStud®

Any larger holes cut into SigmaStud® require a review by the engineer, as load capacity is based on the existence of standard punchout sizes. With the realization that additional holes do manage to appear in studs, TSN provides the SigmaStud (SG) Web RFT to provide reinforcement of a hole or holes added to the stud web during construction, when holes larger than the standard knockout are introduced into the web of the member. Use of the SG Web RFT ensures that the load capacity of the stud is not compromised when these types of oversized holes are present.

- No loss of stud strength when using the SigmaStud Web RFT with up to a 3" hole.
- Each SigmaStud Web RFT contains 12 pre-drilled guide holes in the center section and 12 in the outside flanges, 6 per side, to ensure proper placement of the (24) #12 self-drilling self-tapping screws required.
- All modifications to SigmaStud must be reviewed by a structural engineer.
- Contact TSN's Project Management Team at (888) 474-4876 for more recommendations.
- Non standard holes may not exceed half of stud depth.

3" Maximum Hole Diameter

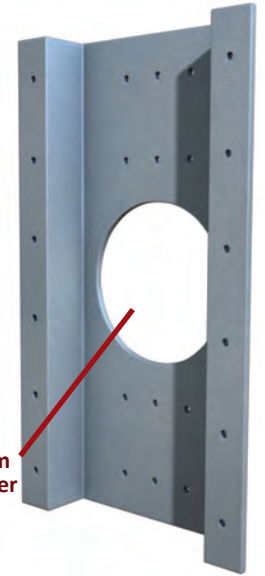

Nomenclature

SigmaStud® Web RFT is available in 54 or 97 mil thicknesses, and is designed for use with 550 & greater sized SigmaStud.

Designate: SG Web RFT-54 or SG Web RFT-97

** Use SG Web RFT-54 for SigmaStud 54mil and lower. Use SG Web RFT-97 for SigmaStud 68mil and higher.*

Material Properties:

ASTM A1003/A1003M or ASTM A653/A653M, G-60 (Z180) minimum hot-dipped galvanized coating; or equivalent. Grade 50 (340), 50ksi (340 MPa) minimum yield strength, 65ksi (450 MPa) minimum tensile strength.



SigmaStud®: Important Design Considerations

Wall In-Line Framing

Building loads must transfer from the vertical element above (e.g. SigmaStud® wall) to the horizontal element (e.g. Floor System), and to the vertical bearing element below (e.g. SigmaStud wall). To achieve this load transfer, the wall framing must align vertically.

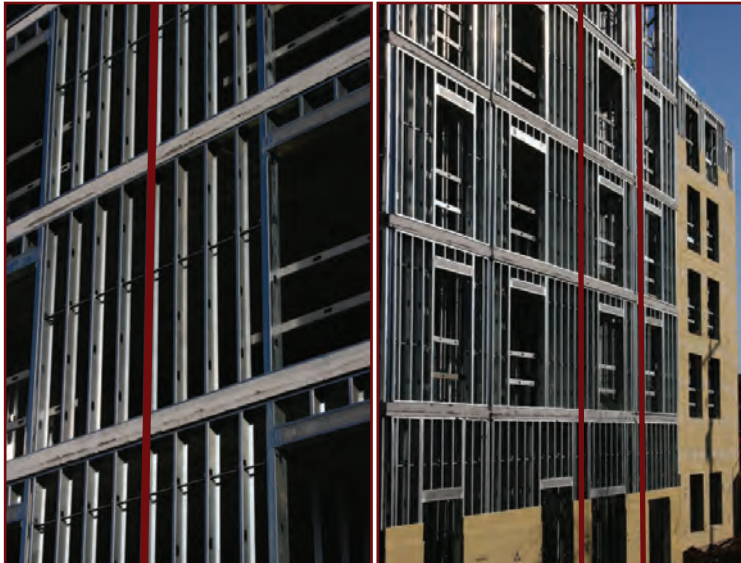

Example of framing aligned vertically. The red lines trace the axial load vertically from the roof to the foundation.

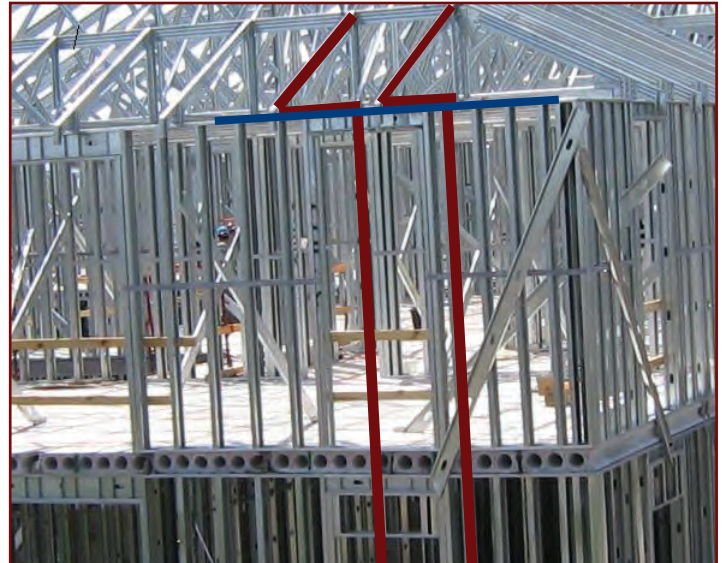

Trusses bearing on the studs, which are aligned vertically to the foundation (red lines). When truss spacing differs from stud spacing, a distribution lintel is required to transfer the load from the truss to the studs below (blue line).



Product Description

SigmaTrak® is the ideal runner track for load bearing and curtain wall metal stud wall assemblies. Manufactured from mill-certified steel, SigmaTrak's unique shape is designed to allow a stud to seat fully within the track, providing full bearing at the top and bottom structural tracks. Load bearing studs must be fully seated within the top and bottom tracks according to design standards.

SigmaTrak eliminates field issues typically seen with (T) section tracks where the studs bear directly on the corner radius of the track, creating gaps between the stud and track.

Benefits That Add Value:

- Track web is oversized to allow the stud to seat fully in the track
- Eliminates the gap between the stud and the track as a result of bearing on corner radii
- Faster assembly than with standard track (no forcing/squeezing stud into bearing on track radii)
- Manufactured from traceable mill-certified steel

Track Recommendations

- The top and bottom track should match the stud thickness
- Minimum track thickness = 54mils
- When welding is required to the top track, it is recommended to use a 14ga (68mils) thickness. Welding may be used as a means of attaching light gauge components, and should be performed by an AWS certified welder.

Material Properties:

ASTM A1003/A1003M or ASTM A653/A653M, G-60 (Z180) minimum hot-dipped galvanized coating; or equivalent. Grade 50 (340), 50ksi (340 MPa) minimum yield strength, 65ksi (450 MPa) minimum tensile strength or 33ksi (230MPa) minimum yield strength, 45ksi (310 MPa) minimum tensile strength.

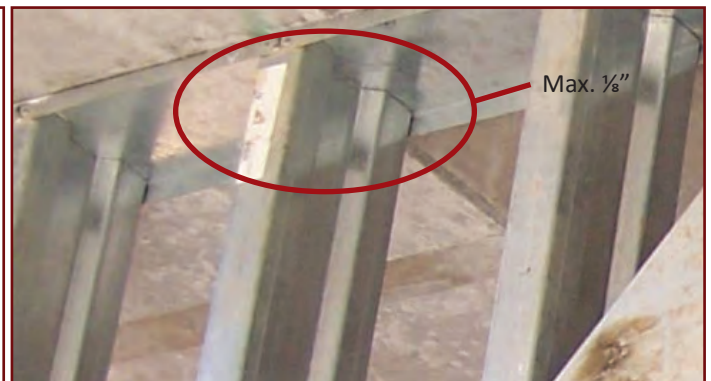
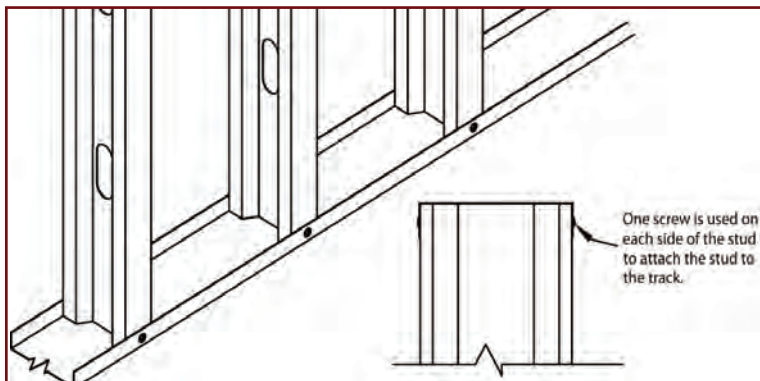
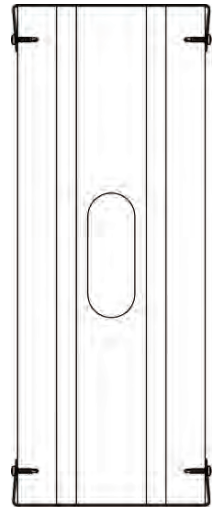

Load bearing walls are designed to fully seat within the top and bottom tracks. Design standards recommend a maximum gap of 1/8" in order to obtain an effective bearing condition.

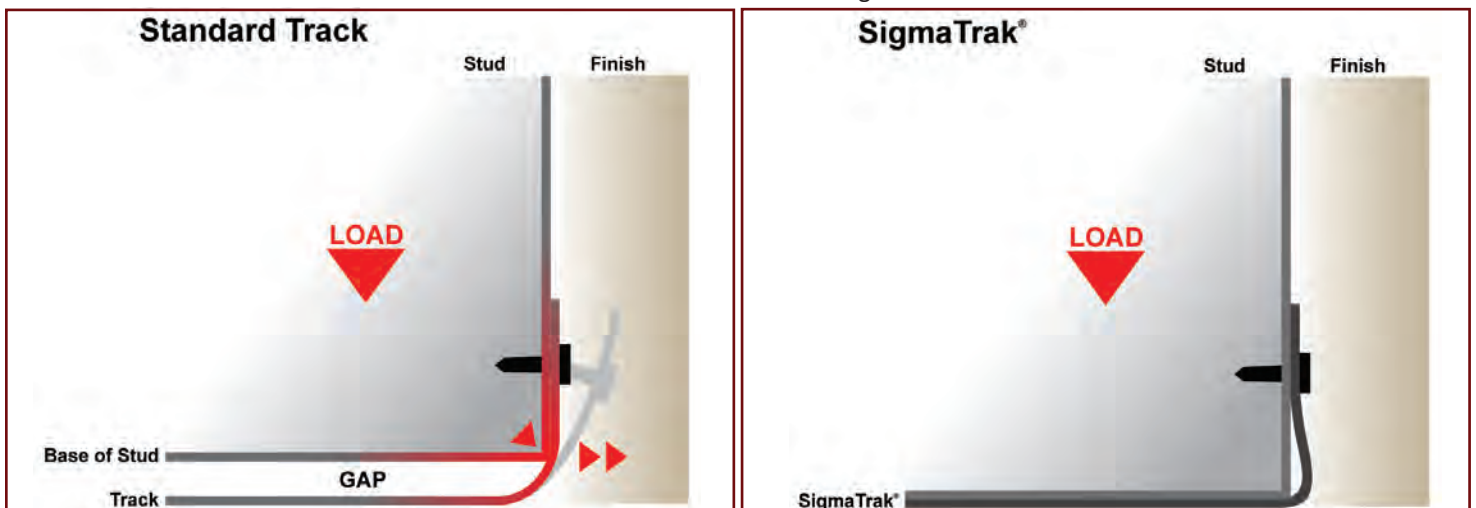

Standard track (T) sections (above left) can contain an inside corner radius that prevents "full" bearing within the track. SigmaTrak (above right) allows full bearing of the stud within the track

Important Notes:

1. Web depth for track sections is equal to the nominal height plus 2 times the design thickness plus 2 times the bend radius.
2. Effective properties incorporate the strength increase from the cold-work of forming as applicable per AISI S100-16 Spec, Sec. A3.3.2 (3).
3. For deflection calculations, use the effective moment of inertia.
4. The effective moment of inertia for deflection is calculated at a stress which results in a section modulus such that the stress times the section modulus at that stress is equal to the allowable moment. AISI S100-16 Procedure I for serviceability determination has been used.

SigmaTrak® Section Properties																		
Section (All 50 ksi)	Design Thickness	Gross Properties							Effective Properties				Torsional					
		Area	Weight	I _x	S _x	R _x	I _y	R _y	I _{xe}	S _{xe}	M _e	V _{ag}	Jx1000	C _w	X _o	m	R _o	β
		(in ²)	(lb/ft)	(in ⁴)	(in ³)	(in)	(in ⁴)	(in)	(in ⁴)	(in ³)	(in-k)	(lb)	(in ⁴)	(in ⁶)	(in)	(in)	(in)	
350SGT150-33	0.0346	0.229	0.778	0.498	0.264	1.476	0.050	0.467	0.409	0.172	5.158	1,053	0.091	0.124	-0.855	0.522	1.769	0.766
350SGT150-43	0.0451	0.298	1.013	0.651	0.343	1.479	0.064	0.465	0.566	0.243	7.263	2,141	0.202	0.162	-0.850	0.519	1.768	0.769
350SGT150-54	0.0566	0.373	1.270	0.820	0.429	1.482	0.080	0.463	0.747	0.327	9.804	3,372	0.399	0.202	-0.845	0.516	1.767	0.772
350SGT150-68	0.0713	0.470	1.599	1.036	0.538	1.485	0.099	0.460	0.988	0.446	13.355	4,679	0.796	0.254	-0.838	0.512	1.766	0.775
350SGT150-97	0.1017	0.669	2.276	1.489	0.761	1.492	0.138	0.454	1.489	0.717	21.456	6,674	2.306	0.359	-0.824	0.504	1.764	0.782
350SGT150-118	0.1242	0.815	2.775	1.829	0.924	1.497	0.165	0.450	1.829	0.924	27.665	8,150	4.193	0.435	-0.813	0.498	1.762	0.787
350SGT200-33	0.0346	0.263	0.895	0.619	0.328	1.534	0.109	0.645	0.470	0.172	5.144	1,053	0.105	0.271	-1.271	0.754	2.094	0.632
350SGT200-43	0.0451	0.343	1.167	0.810	0.426	1.537	0.142	0.643	0.649	0.256	7.674	2,141	0.232	0.353	-1.266	0.751	2.093	0.634
350SGT200-54	0.0566	0.430	1.463	1.020	0.534	1.541	0.176	0.641	0.862	0.348	10.411	3,372	0.459	0.442	-1.260	0.748	2.091	0.637
350SGT200-68	0.0713	0.541	1.841	1.291	0.670	1.545	0.220	0.638	1.151	0.477	14.296	4,679	0.917	0.557	-1.252	0.744	2.088	0.640
350SGT200-97	0.1017	0.770	2.622	1.859	0.950	1.553	0.308	0.632	1.788	0.784	23.473	6,674	2.656	0.792	-1.237	0.735	2.084	0.648
350SGT200-118	0.1242	0.940	3.198	2.285	1.155	1.559	0.371	0.628	2.281	1.035	30.999	8,150	4.832	0.965	-1.226	0.729	2.080	0.653
362SGT150-33	0.0346	0.233	0.792	0.537	0.275	1.519	0.050	0.465	0.442	0.181	5.423	1,017	0.093	0.134	-0.844	0.517	1.799	0.780
362SGT150-43	0.0451	0.303	1.032	0.702	0.358	1.522	0.065	0.463	0.611	0.255	7.625	2,141	0.206	0.175	-0.839	0.514	1.798	0.782
362SGT150-54	0.0566	0.380	1.294	0.884	0.448	1.524	0.081	0.461	0.806	0.343	10.279	3,372	0.406	0.218	-0.833	0.511	1.797	0.785
362SGT150-68	0.0713	0.479	1.629	1.117	0.562	1.528	0.100	0.458	1.066	0.467	13.983	4,846	0.811	0.274	-0.827	0.507	1.796	0.788
362SGT150-97	0.1017	0.681	2.319	1.605	0.795	1.535	0.139	0.452	1.605	0.749	22.423	6,912	2.350	0.387	-0.813	0.499	1.794	0.795
362SGT150-118	0.1242	0.831	2.828	1.970	0.965	1.540	0.167	0.448	1.970	0.965	28.893	8,441	4.273	0.469	-0.802	0.493	1.793	0.800
362SGT200-33	0.0346	0.267	0.910	0.667	0.342	1.579	0.111	0.643	0.508	0.178	5.321	1,017	0.107	0.292	-1.257	0.748	2.118	0.648
362SGT200-43	0.0451	0.348	1.186	0.872	0.444	1.582	0.143	0.641	0.699	0.269	8.057	2,141	0.236	0.380	-1.252	0.745	2.117	0.650
362SGT200-54	0.0566	0.437	1.487	1.098	0.556	1.585	0.178	0.639	0.929	0.365	10.915	3,372	0.467	0.477	-1.246	0.742	2.115	0.653
362SGT200-68	0.0713	0.550	1.872	1.389	0.699	1.589	0.222	0.636	1.239	0.500	14.965	4,846	0.932	0.600	-1.238	0.738	2.113	0.657
362SGT200-97	0.1017	0.783	2.665	1.999	0.990	1.598	0.311	0.630	1.923	0.819	24.518	6,912	2.700	0.854	-1.223	0.729	2.108	0.664
362SGT200-118	0.1242	0.955	3.251	2.457	1.203	1.604	0.374	0.626	2.452	1.080	32.345	8,441	4.912	1.040	-1.212	0.723	2.105	0.669
400SGT150-33	0.0346	0.246	0.837	0.666	0.311	1.646	0.052	0.458	0.555	0.198	5.931	921	0.098	0.167	-0.812	0.502	1.892	0.816
400SGT150-43	0.0451	0.320	1.090	0.870	0.405	1.648	0.067	0.456	0.759	0.292	8.755	2,041	0.217	0.216	-0.807	0.499	1.891	0.818
400SGT150-54	0.0566	0.402	1.367	1.095	0.506	1.651	0.083	0.454	0.999	0.393	11.758	3,372	0.429	0.271	-0.802	0.496	1.891	0.820
400SGT150-68	0.0713	0.505	1.720	1.383	0.636	1.654	0.103	0.451	1.320	0.532	15.936	5,348	0.857	0.339	-0.795	0.492	1.890	0.823
400SGT150-97	0.1017	0.720	2.449	1.985	0.899	1.661	0.143	0.445	1.985	0.849	25.421	7,628	2.481	0.478	-0.782	0.484	1.889	0.829
400SGT150-118	0.1242	0.878	2.987	2.434	1.092	1.665	0.171	0.441	2.434	1.092	32.696	9,314	4.512	0.579	-0.772	0.479	1.888	0.833
400SGT200-33	0.0346	0.280	0.954	0.822	0.384	1.712	0.114	0.637	0.634	0.195	5.849	921	0.112	0.362	-1.216	0.731	2.194	0.693
400SGT200-43	0.0451	0.365	1.243	1.074	0.500	1.715	0.147	0.635	0.866	0.309	9.251	2,041	0.248	0.471	-1.211	0.728	2.193	0.695
400SGT200-54	0.0566	0.458	1.559	1.352	0.626	1.718	0.183	0.633	1.147	0.417	12.482	3,372	0.489	0.591	-1.205	0.725	2.192	0.698
400SGT200-68	0.0713	0.577	1.963	1.710	0.786	1.722	0.229	0.630	1.527	0.569	17.044	5,348	0.977	0.743	-1.198	0.720	2.190	0.701
400SGT200-97	0.1017	0.821	2.795	2.458	1.114	1.730	0.320	0.624	2.364	0.927	27.753	7,628	2.832	1.055	-1.183	0.712	2.187	0.707
400SGT200-118	0.1242	1.002	3.409	3.017	1.354	1.736	0.385	0.620	3.010	1.219	36.501	9,314	5.151	1.284	-1.172	0.706	2.184	0.712

Refer to Important Table Notes on Page 19

SigmaTrak® Section Properties																			
Section (All 50 ksi)	Design Thickness	Gross Properties							Effective Properties				Torsional						
		Area	Weight	I _x	S _x	R _x	I _y	R _y	I _{xe}	S _{xe}	M _a	V _{ag}	Jx1000	C _w	X _o	m	R _o	β	
		(in ²)	(lb/ft)	(in ⁴)	(in ³)	(in)	(in ⁴)	(in)	(in ⁴)	(in ³)	(in-k)	(lb)	(in ⁴)	(in ⁶)	(in)	(in)	(in)		
550SGT150-33	0.0346	0.298	1.013	1.363	0.472	2.140	0.056	0.433	1.175	0.265	7.940	670	0.119	0.338	-0.706	0.450	2.294	0.905	
550SGT150-43	0.0451	0.388	1.320	1.779	0.613	2.142	0.072	0.431	1.576	0.451	13.490	1,484	0.263	0.438	-0.702	0.448	2.294	0.906	
550SGT150-54	0.0566	0.486	1.656	2.235	0.768	2.144	0.089	0.428	2.055	0.618	18.490	2,934	0.520	0.546	-0.697	0.445	2.295	0.908	
550SGT150-68	0.0713	0.612	2.084	2.821	0.964	2.146	0.111	0.426	2.699	0.827	24.764	5,352	1.038	0.683	-0.692	0.442	2.295	0.909	
550SGT150-97	0.1017	0.872	2.968	4.037	1.365	2.151	0.154	0.420	4.037	1.298	38.850	10,488	3.007	0.959	-0.680	0.434	2.295	0.912	
550SGT150-118	0.1242	1.064	3.621	4.941	1.658	2.155	0.184	0.416	4.941	1.658	49.655	12,807	5.470	1.157	-0.671	0.429	2.295	0.915	
550SGT200-33	0.0346	0.332	1.131	1.648	0.570	2.227	0.124	0.611	1.323	0.266	7.955	670	0.133	0.733	-1.078	0.669	2.549	0.821	
550SGT200-43	0.0451	0.433	1.473	2.152	0.742	2.230	0.161	0.609	1.783	0.445	13.323	1,484	0.294	0.953	-1.073	0.666	2.548	0.823	
550SGT200-54	0.0566	0.543	1.848	2.706	0.929	2.232	0.200	0.607	2.321	0.654	19.589	2,934	0.580	1.192	-1.068	0.663	2.548	0.824	
550SGT200-68	0.0713	0.684	2.327	3.416	1.167	2.235	0.249	0.604	3.071	0.882	26.402	5,352	1.159	1.496	-1.062	0.659	2.547	0.826	
550SGT200-97	0.1017	0.974	3.314	4.895	1.656	2.242	0.349	0.598	4.713	1.408	42.160	10,488	3.358	2.115	-1.048	0.651	2.546	0.831	
550SGT200-118	0.1242	1.188	4.043	5.997	2.013	2.247	0.419	0.594	5.974	1.834	54.897	12,807	6.109	2.566	-1.038	0.645	2.545	0.834	
600SGT150-33	0.0346	0.315	1.072	1.667	0.531	2.300	0.057	0.425	1.391	0.273	8.186	614	0.126	0.410	-0.677	0.436	2.435	0.923	
600SGT150-43	0.0451	0.410	1.397	2.175	0.690	2.302	0.073	0.423	1.936	0.431	12.915	1,361	0.278	0.531	-0.673	0.433	2.435	0.924	
600SGT150-54	0.0566	0.515	1.752	2.733	0.864	2.304	0.091	0.420	2.543	0.630	18.871	2,689	0.550	0.663	-0.669	0.430	2.436	0.925	
600SGT150-68	0.0713	0.648	2.205	3.447	1.085	2.306	0.113	0.418	3.310	0.911	27.262	5,352	1.098	0.828	-0.663	0.427	2.436	0.926	
600SGT150-97	0.1017	0.923	3.141	4.930	1.537	2.311	0.157	0.412	4.930	1.464	43.836	10,888	3.182	1.162	-0.652	0.420	2.436	0.928	
600SGT150-118	0.1242	1.126	3.832	6.032	1.868	2.315	0.187	0.408	6.032	1.868	55.928	13,972	5.790	1.401	-0.643	0.415	2.437	0.930	
600SGT200-33	0.0346	0.350	1.190	2.004	0.638	2.394	0.127	0.602	1.626	0.289	8.659	614	0.140	0.891	-1.039	0.650	2.679	0.849	
600SGT200-43	0.0451	0.456	1.550	2.616	0.830	2.396	0.164	0.600	2.190	0.482	14.433	1,361	0.309	1.157	-1.035	0.647	2.678	0.851	
600SGT200-54	0.0566	0.571	1.945	3.288	1.040	2.399	0.204	0.598	2.831	0.743	22.252	2,689	0.610	1.447	-1.030	0.644	2.678	0.852	
600SGT200-68	0.0713	0.719	2.448	4.150	1.307	2.402	0.255	0.595	3.739	0.998	29.889	5,352	1.219	1.815	-1.023	0.641	2.678	0.854	
600SGT200-97	0.1017	1.025	3.487	5.943	1.853	2.408	0.356	0.590	5.724	1.586	47.480	10,888	3.533	2.565	-1.010	0.633	2.677	0.858	
600SGT200-118	0.1242	1.250	4.255	7.277	2.254	2.413	0.428	0.585	7.247	2.059	61.657	13,972	6.428	3.109	-1.001	0.627	2.677	0.860	
800SGT150-33 ¹	0.0346	0.384	1.308	3.298	0.797	2.930	0.060	0.396	2.690	0.369	11.050	461	0.153	0.780	-0.583	0.385	3.013	0.963	
800SGT150-43	0.0451	0.501	1.704	4.301	1.036	2.931	0.078	0.394	3.762	0.587	17.588	1,020	0.339	1.010	-0.579	0.383	3.014	0.963	
800SGT150-54	0.0566	0.628	2.137	5.401	1.298	2.933	0.096	0.392	4.985	0.868	25.994	2,017	0.671	1.259	-0.575	0.380	3.014	0.964	
800SGT150-68	0.0713	0.791	2.691	6.808	1.630	2.934	0.120	0.389	6.596	1.275	38.162	4,032	1.340	1.571	-0.571	0.377	3.014	0.964	
800SGT150-97	0.1017	1.126	3.833	9.722	2.311	2.938	0.166	0.384	9.722	2.205	66.005	10,888	3.884	2.197	-0.560	0.370	3.015	0.965	
800SGT150-118	0.1242	1.374	4.677	11.883	2.810	2.940	0.198	0.380	11.883	2.810	84.125	16,239	7.067	2.644	-0.553	0.366	3.016	0.966	
800SGT200-33 ¹	0.0346	0.419	1.425	3.886	0.939	3.046	0.136	0.569	2.987	0.376	11.269	461	0.167	1.702	-0.910	0.586	3.230	0.921	
800SGT200-43	0.0451	0.546	1.857	5.069	1.222	3.048	0.175	0.567	4.188	0.603	18.044	1,020	0.370	2.209	-0.906	0.583	3.230	0.921	
800SGT200-54	0.0566	0.685	2.330	6.368	1.530	3.050	0.218	0.565	5.566	0.897	26.856	2,017	0.731	2.760	-0.902	0.580	3.230	0.922	
800SGT200-68	0.0713	0.862	2.933	8.030	1.923	3.052	0.272	0.562	7.389	1.330	39.815	4,032	1.461	3.456	-0.896	0.577	3.230	0.923	
800SGT200-97	0.1017	1.228	4.179	11.479	2.729	3.057	0.380	0.556	11.090	2.352	70.424	10,888	4.234	4.870	-0.885	0.570	3.231	0.925	
800SGT200-118	0.1242	1.499	5.100	14.039	3.320	3.061	0.457	0.552	13.968	3.067	91.823	16,239	7.706	5.892	-0.876	0.564	3.231	0.927	

¹ Web-height to thickness ratio exceeds 200. Web stiffeners are required at all support points and concentrated loads.

Redefining Design Assist

The Steel Network identifies design assist opportunities when framing with Cold-Formed Steel (CFS) systems. CFS is proven to reduce overall costs and accelerate construction schedules while meeting building code requirements.

- Lower overall project costs
- Material cost savings in the wall system
- Reduced foundation requirements and cost
- Accelerated construction schedules
- Fewer subcontractors on the job
- Satisfied Developers, Contractors, Structural Engineers and Architects



What does TSN's Design Assist Service Provide?

- 1. Partnership:** TSN will partner with the project team to recommend the best solutions to fit project conditions. Our services apply at any point in the project; from the Architect, Engineer of Record, General Contractor, Sub-Contractor, Specialty Engineer (Shop Drawer), to the Distributor. Each member of the team can partner with TSN to determine the best course of action for the project.
- 2. Budgeting/Cost Certainty:** TSN's expertise may enable over-budgeted projects to meet budget, and may also provide substantial savings to projects already within a posted budget. TSN's DA services have provided significant savings in the wall system as well as in the secondary systems, such as foundations.
- 3. Flexibility:** The project design team is empowered to determine the best foundation, floor, and roof systems for the project.
- 4. Scheduling:** TSN's DA services often result in accelerated construction schedules which, in turn, save resources.

Optimizing the Structure

The Steel Network's load bearing wall systems (LBWS) create the opportunity to fully-optimize the structural systems, including walls, floors, and the building's foundation. Use of SigmaStud® (8psf) in place of the much heavier concrete/masonry block (45psf) enables the Structural Engineer to determine if a more efficient foundation, including the elimination of geo-piers is possible. "Real world" experience proves time and time again the tremendous value TSN's LBWS delivers to the construction team.

TSN's Load Bearing Wall Systems provide approximately \$2/sq.ft. of material cost savings *in addition to* the significant time/labor savings related to scheduling and installation.

Electrical Consideration

In concrete/masonry walls, electrical wires are installed on both sides of the masonry in gaps provided by some type of furring channel. This adds to the cost of concrete/masonry in the comparison above. This added expense is not seen in TSN's SigmaStud due to the pre-punched knockouts located vertically at 24" o.c.



SigmaStud's punchouts provide a convenient avenue for electrical chase.

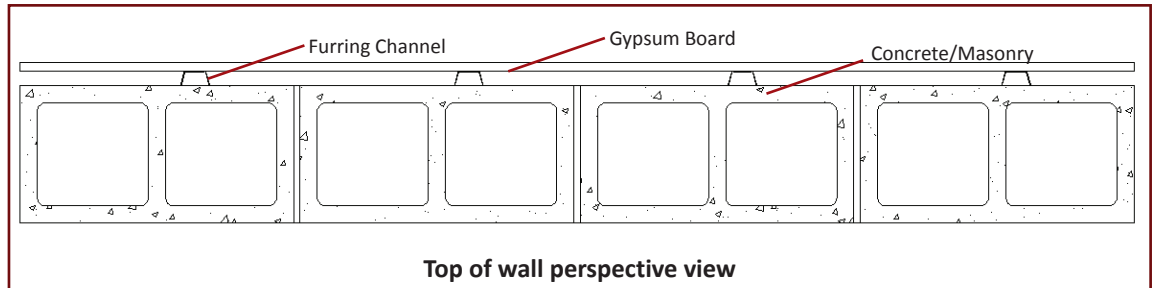

Concrete/Masonry walls require additional furring for installation of finishes and wiring.

Temporary Construction Bracing

Temporary construction bracing is necessary in order to install steel framed load bearing wall systems. Coordinate temporary bracing with the Specialty Engineer and/or the General Contractor. Safe and proper installation and “loading” of the walls can only be achieved if the adequate temporary bracing is installed. **Failure to do this can result in wall failure and/or the risk of serious injury.**

Two types of construction bracing are required:

- In the plane of the wall (may employ the X-bracing of the shear wall panels and/or by adding diagonal kickers at the two ends of the wall).
- Out of the plane of the wall.

When should temporary construction bracing be removed?

- After at least 2 floors above the temporarily braced wall are installed, allowing the walls to “seat”.
- After all permanent shear wall bracing is installed and tightened.
- After all of the perpendicular walls are connected.



Suggested Minimum Construction Bracing for Load Bearing Wall 10' or Less, Out-of-Plane

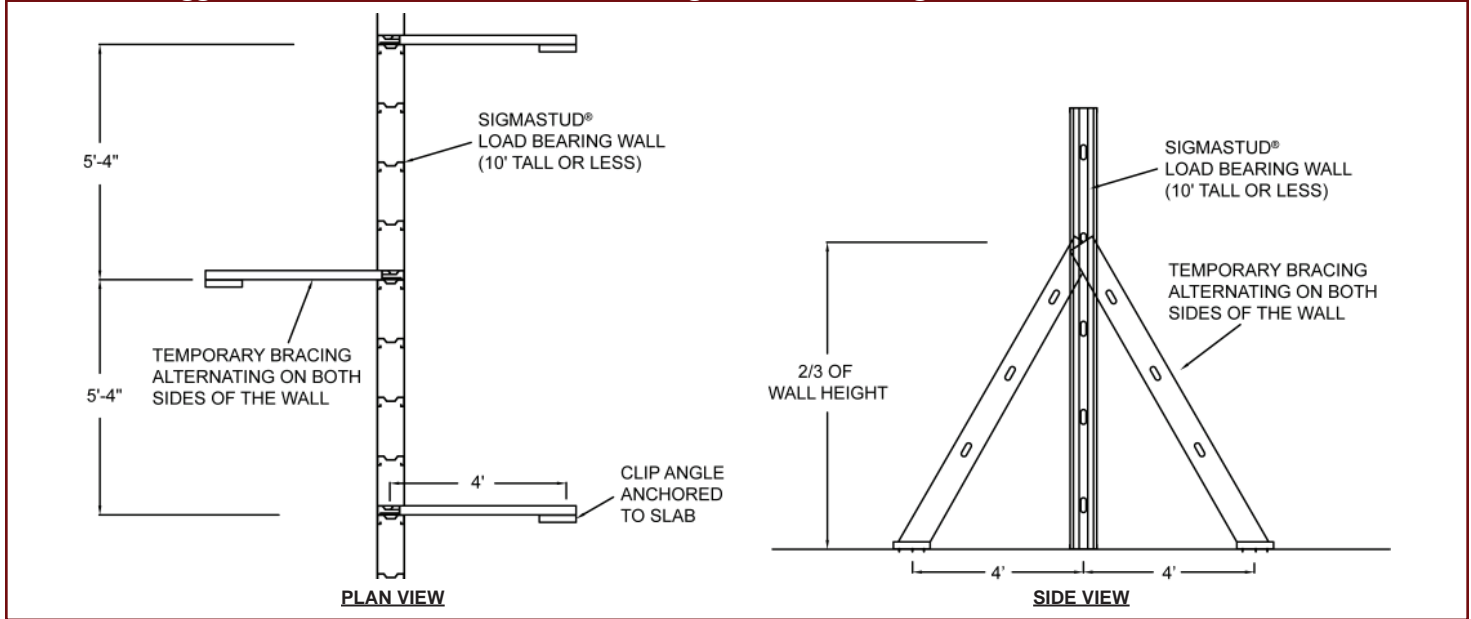

* Temporary bracing should be designed by a design professional.

Suggested Minimum Construction Bracing for Load Bearing Wall: In-Plane at Corridor

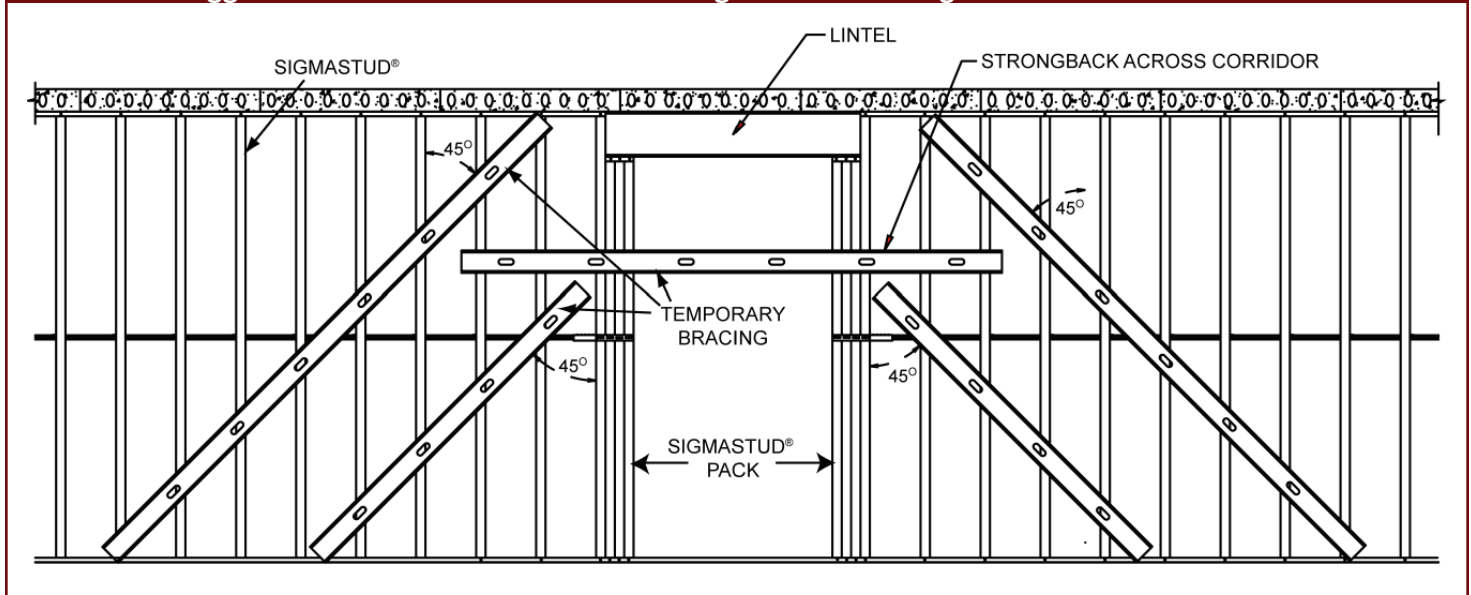

Additional temporary bracing details are available at www.steelnetwork.com

Description

TSN's *Load Bearing Wall Systems Construction Guide* provides an in-depth look into a variety of design and installation conditions concerning use of SigmaStud® and StiffWall® in construction projects. The purpose of the guide is to educate contractors, architects and engineers on the proper use of TSN's load bearing wall systems on the job site. The Steel Network wants to ensure that our customers fully understand these systems and are supplied with detailed information addressing installation issues, including the following:

- SigmaStud installation to the top and bottom tracks
- Track recommendations
- Shims
- Reinforcing non-standard holes in SigmaStud
- Temporary construction bracing
- Corridor framing
- Panelized walls
- Key wall bridging issues

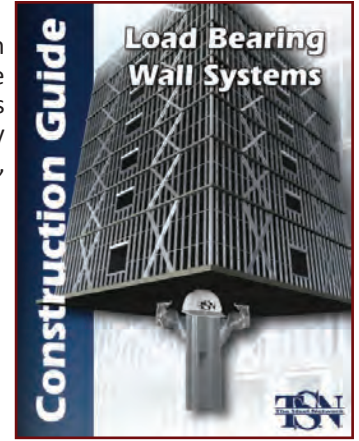

Track Reinforcement

The top and bottom wall tracks in contact with hollowcore planks need to be continuous. The contractor must provide track splicing if the tracks are cut.

- To splice track in a load-bearing wall, an extra piece of stud must be used inside the track to sufficiently overlap each side of the joint. 2-3 screws are then installed through the flanges on each side of the joint, on both sides of the track (for a total of 8-12 screws per splice).
- In adjacent walls ending with edge studs, a plate may be screwed or welded across the flanges of the end studs of two adjacent walls. In addition to this, the studs must be screwed or welded together per standard column/screw guidelines.

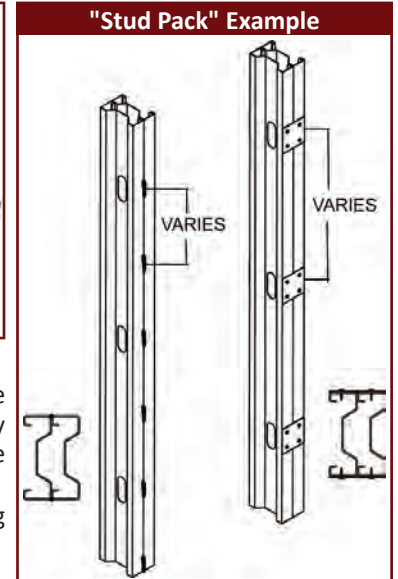
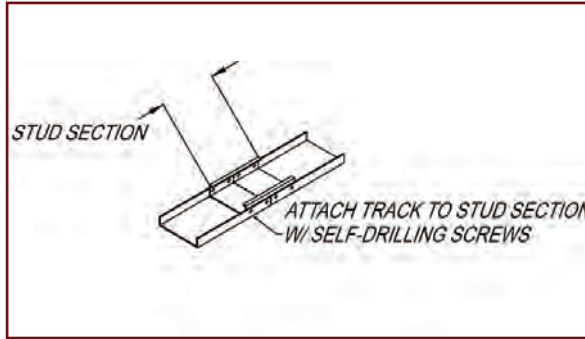

Corridor Framing

In applications where the plank spans bays that are parallel to the corridor, plank direction can be maintained in the corridor through the use of a load distribution lintel. Structural steel is commonly used to act as the lintel to support the opening, resulting in increased point loads acting on the columns. Bearing requirements for various types of structural steel vary and must be satisfied.

- Typically, multiple studs of the same thickness are used in "stud-packs" to provide bearing points for structural steel lintels.
- Coordinate the use of "stud packs" with the structural engineer.

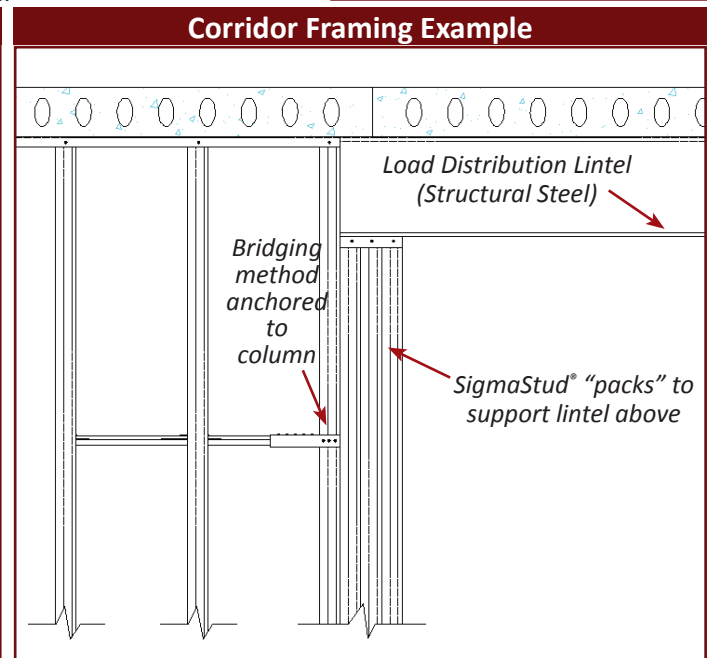
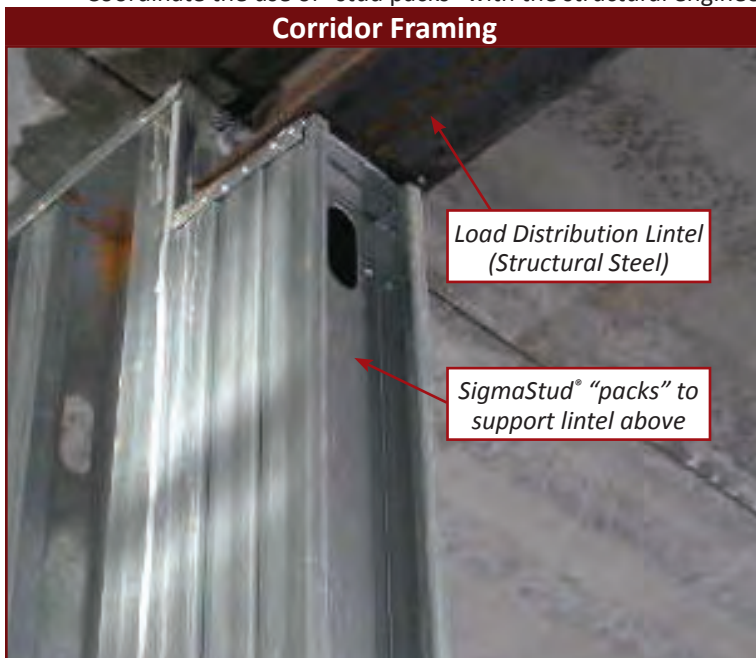

Load Bearing Wall Members

Construction Guide - Wall Studs

Embedded Plates

If the floor system consists of hollow core planks:

- Typically attach the top track to the floor above by welding the bottom of a key plate (Splice Plate) to the track.
- The key is then grouted in between the two planks, connecting the floor system to the rest of the structure.
- Embedded bolts/anchors and power actuated fasteners can also serve to connect the load bearing walls with various floor diaphragms, per the structural engineer's specifications.
- Be sure to clarify specific methods of attachment with the engineer.

Visit www.steelnetwork.com for a copy of the Construction Guide!

Splice Plate Example

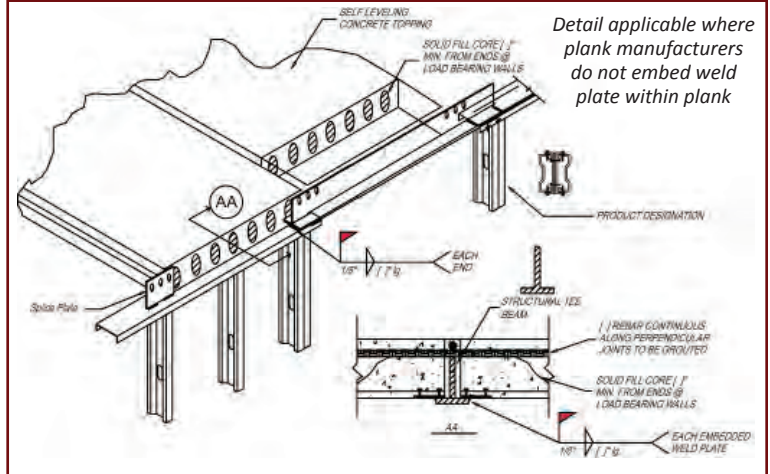

Detail applicable where plank manufacturers do not embed weld plate within plank

Embedded Plate Detail - HC Plank

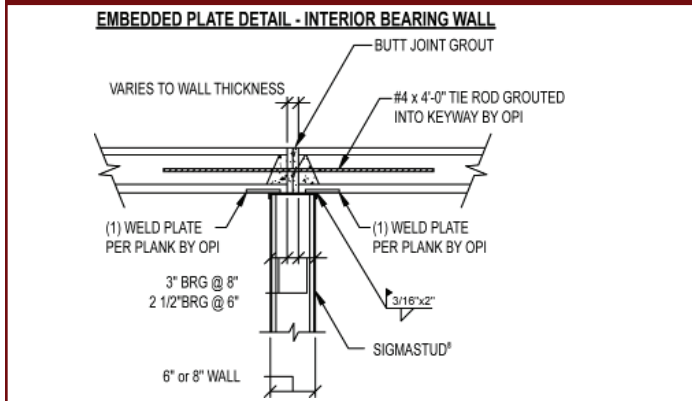

Embedded Plate Detail - Exterior Bearing Wall

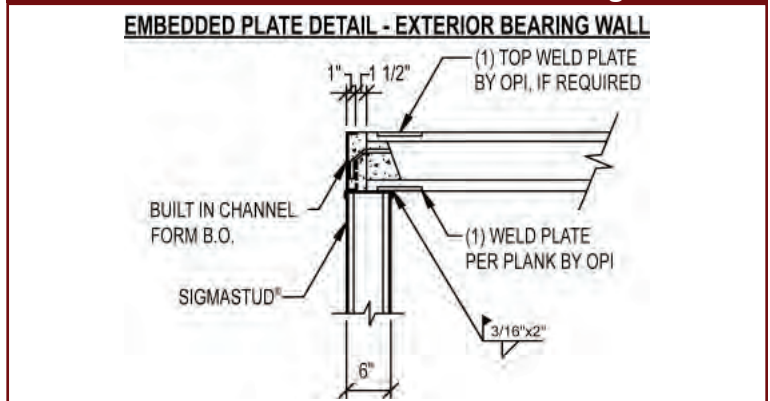

Wall Panel Handling

When lifting wall panels into place, **avoid using the bridging as a lift point**. This could bend the bridging members, rendering them ineffective. Here are two suggestions that have worked well in existing installations:

- Attach a temporary stud or other bracing member ("strong back") horizontally across the wall panel and use it to lift the wall sections into place.
- Thread the cables through the stud punchouts at either end to lift the panel.

Strong Back

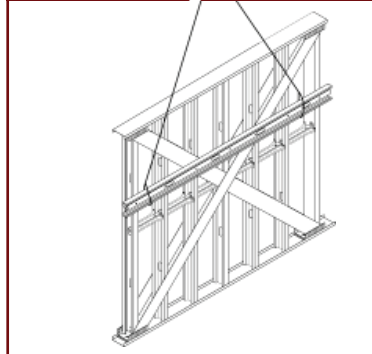

Threaded Cable

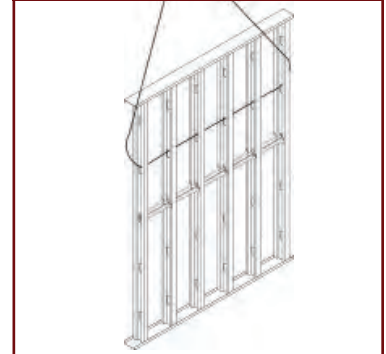

Design Example

Using the requirements of Section B3.4.1.2 in the AISI S240-15 Standard for Cold-Formed Steel Structural Framing design BuckleBridge® lateral bracing system for an 8 ft. tall CFS load bearing wall. The wall consists of 800SG200-54 studs spaced at 16 inches o.c.

Solution

a) Design compression load per stud, $P = 11.5$ kips:

From SigmaStud charts, 8 ft. Wall Height, No Lateral Load:
 One row of lateral bracing, unbraced length $L_b = 48$ inches
 800SG200-54, Allowable strength $P_a = 12.04$ kips

b) Required bridging strength for a single SigmaStud:

$$P_{br,1} = 0.02(11.5 \text{ kips}) = 0.23 \text{ kips}$$

c) Check the strength of BuckleBridge:

Since the bridging row can resist lateral bracing forces either in compression or in tension, the maximum wall length that can be braced before anchorage is determined from the load capacity of BuckleBridge in compression and tension as follows:

Maximum number of studs that can be braced in **compression** = BuckleBridge $P_{Comp} / P_{br,1}$
 = 2.4 kips / 0.23 kips = 10 studs

Maximum number of studs that can be braced in **tension** = BuckleBridge $P_{Tension} / P_{br,1}$
 = 0.44 kips / 0.23 kips = 1 stud

Maximum number of studs that can be braced before anchorage = (10 + 1 + 1) studs = 12 studs (see chart below)

The lateral bracing needs to be anchored at rigid columns every 12 studs = 16 ft 0 in.

Use double SigmaStud® section or JamStud® section as a rigid column at anchorage locations (see anchorage details).

Design rigid columns for a lateral force = 12 x 0.23 kips = 2.76 kips

Alternatively, use cross-bracing to floor system as the anchorage method (see anchorage details).

Note: AISI S100-07 requires less capacity for the lateral bracing (bridging) row, but mandates additional stiffness requirements. Check BuckleBridge stiffness capacity.

Anchorage solution should be checked to ensure it is capable of resisting the load transferred from the bridging member.

Wall Bridging Figure

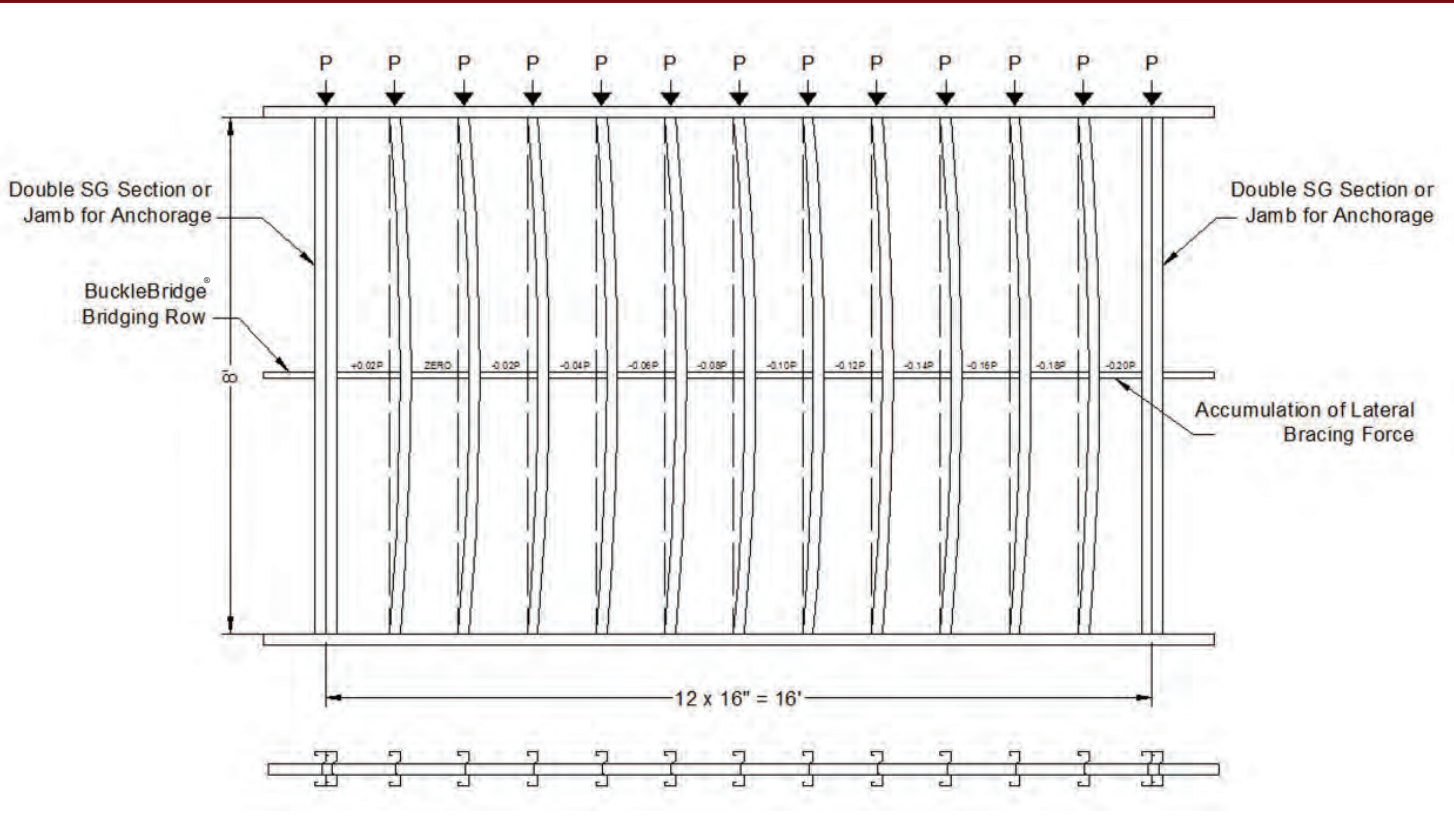

Anchorage of Lateral Bracing (Bridging) Forces

Load Bearing Wall Bridging Row Anchored to Jamb Stud or End Column - Track Bracing Utilizing BridgeBar® 150 with BC600 / BC800

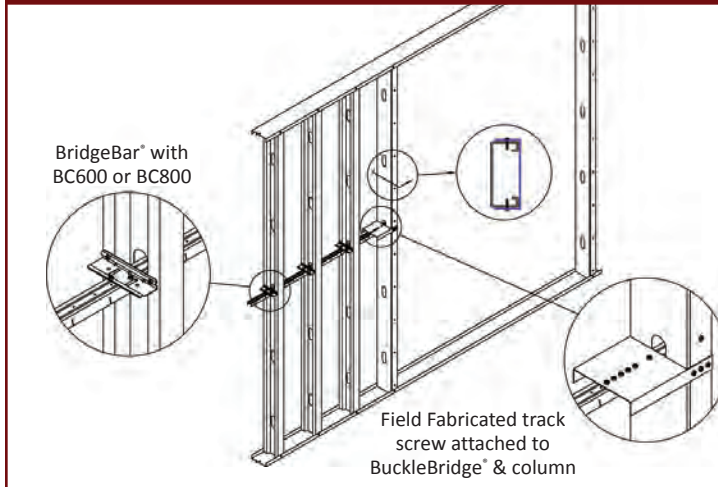

Load Bearing Wall Bridging Row Anchored to Jamb Stud or End Column - Track Bracing Utilizing BuckleBridge®

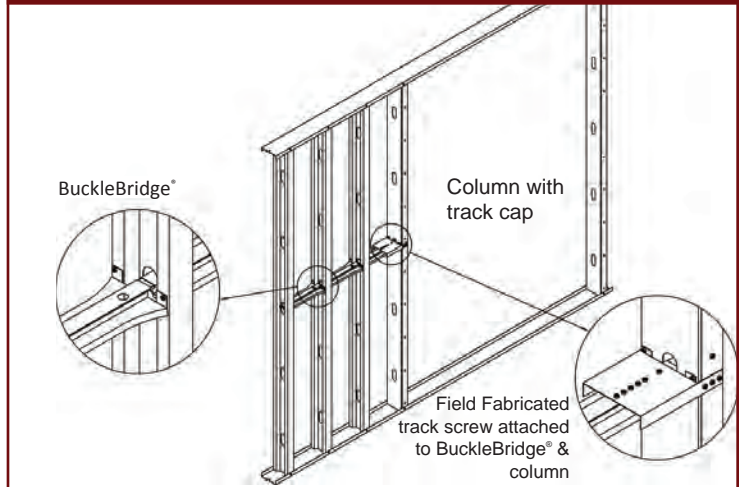

Load Bearing Wall Bridging Row Anchored to Floor System Through Cross Bracing - Utilizing BridgeBar® 150 with BC600 / BC800

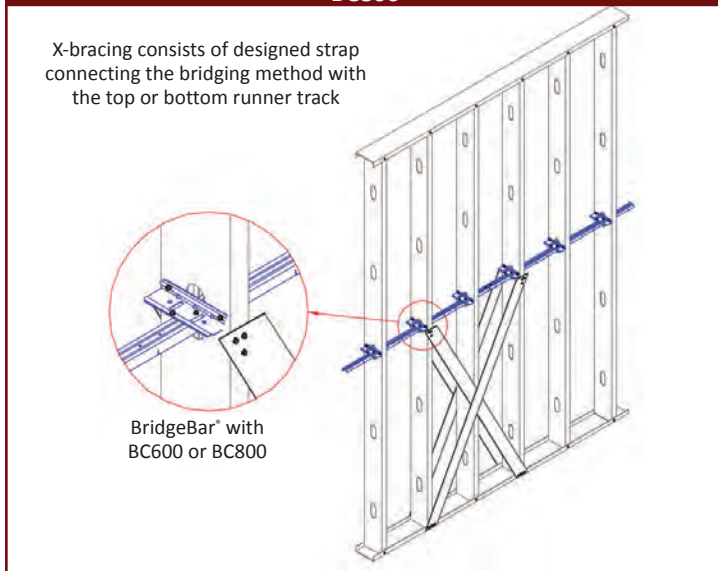

Load Bearing Wall Bridging Row Anchored to Floor System Through Cross Bracing - Utilizing BuckleBridge®

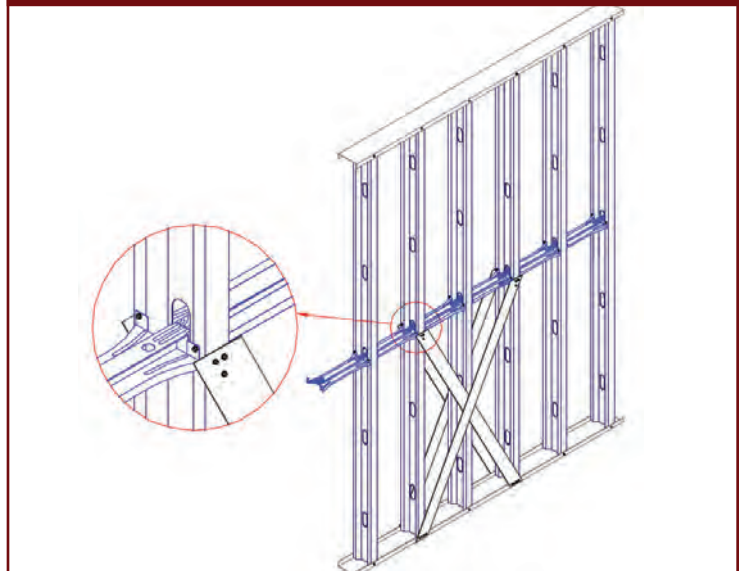

Load Bearing Wall Bridging Row Anchored to Jamb Stud or End Column - Flat Strap Bracing w/ Blocking

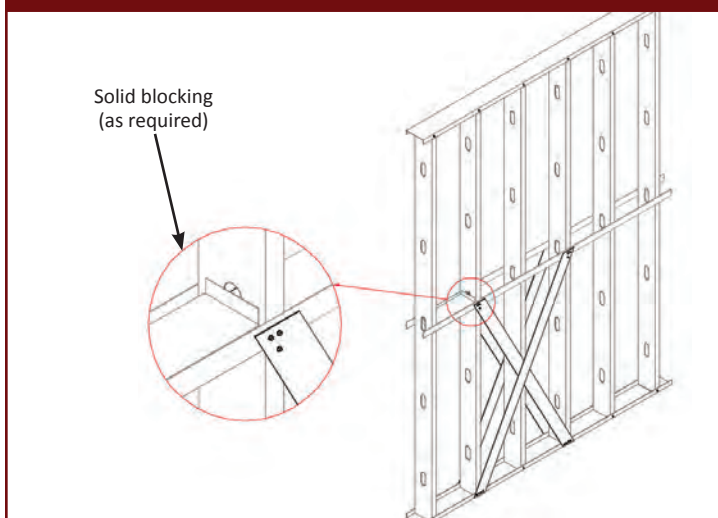

Load Bearing Wall Bridging Row Anchored to Jamb Stud or End Column - Flat Strap Bracing w/ Blocking

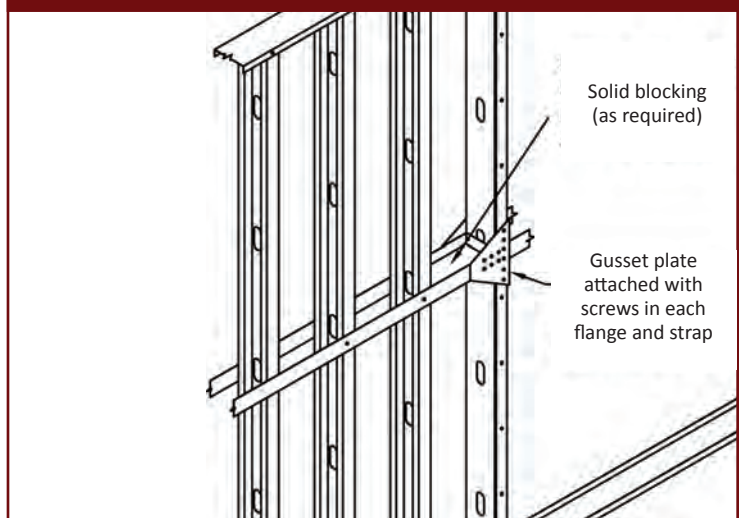

600C/STW250-68-1-SM-10ft-9-1/4"

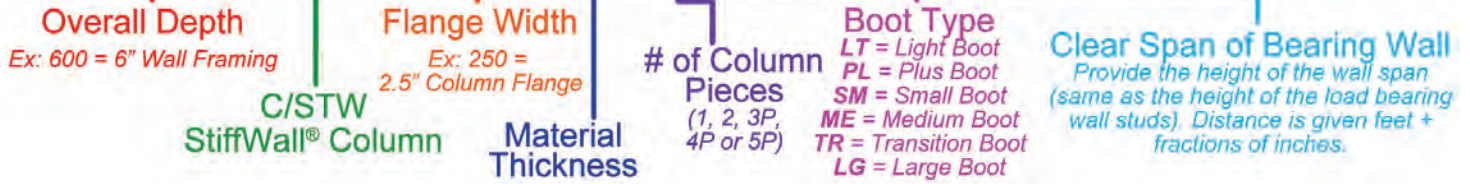

Background

StiffWall® SWS is a stick build system designed to carry loads concentrically from the point of applied loads to the foundation or other termination point, that utilizes light gage straps on both sides of the wall for shear resistance. StiffWall provides superior quality with high yield ASTM A1003 steel and hot-dipped galvanized coating for long-term durability. It is specified using simple nomenclature indicating only essential design requirements for each shear wall element. The design is ideal for job specific sizes with established load requirements. The Steel Network has optimized the design and fabrication of StiffWall through a series of both component and full scale wall assembly tests, using state of the art technology to measure performance.

StiffWall shear walls provide both lateral strength and stiffness. Lateral strength is needed to resist horizontal loads due to wind and earthquake forces. Properly designed and constructed shear walls transfer lateral forces to the next structural element in the load path below them, such as other shear walls, floors, or foundations.

Lateral stiffness is needed to prevent excessive side-sway of the structure. When shear walls are of adequate stiffness, they will maintain the lateral deflection or serviceability requirements of the building. In addition, buildings with sufficient lateral stiffness will suffer less nonstructural damage, further avoiding long-term degradation due to veneer cracking and water infiltration.

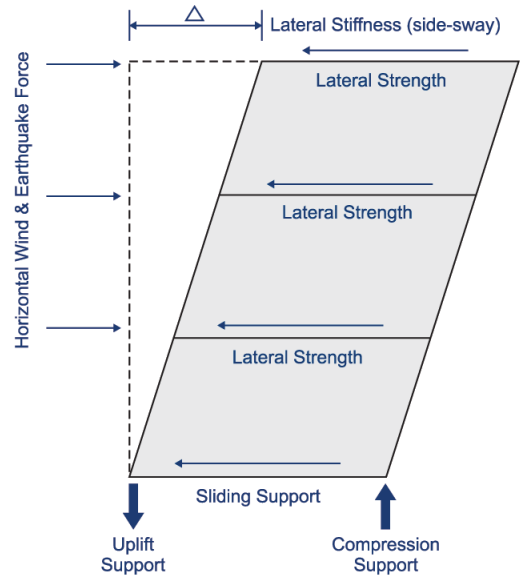

StiffWall System Components:

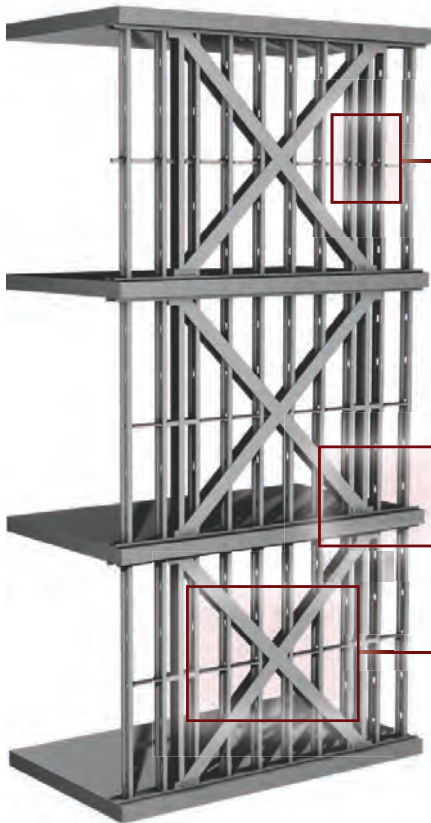

Columns (C/STW)

- End posts for the shear wall
- Wider flange and additional return lips provide an increased load capacity over standard steel stud sections



Boots

- Made up of a Strap Track (97 mil, 12" long track section with pre-punched screw pilot holes) and a Base Plate ("T" shaped structural steel), specified bolts for connection to column, and is designed to fit into a standard size track.
- Transfers the loads from the straps and columns through the floor system down to the foundation
- Pre-installed on top and bottom of each column by TSN
- Fits into a standard track (T) section



Flat Strap

- Runs diagonally (corner to corner) as a single piece and attaches to the strap track in an "X" pattern
- Four (4) pieces of flat strap are used in each StiffWall (2 pcs each side)
- Made to your specifications, always using 50 ksi steel



TightStrap®

- Device used to tension (tighten) flat strap in the field
- Removes "waviness" or "bowing" prior to fastening
- Ensures flat straps are as tight as possible when installed to achieve optimal system performance
- Fastens to standard track at the corners of the shear wall to provide a base for the tensioning process

* The infill studs are not part of the StiffWall system and act independently of the shear wall. The floor slabs are part of the lateral load resisting system, but are not part of TSN StiffWall system.

Planning Shear Walls

To develop an efficient shear wall layout several factors need to be considered:

- Height to Width aspect ratio guidelines should be observed in order to maximize effectiveness
- Shear walls should be evenly distributed across the floor plan to reduce additional lateral loads resulting from torsional effects on the floor plan
- Shear Walls located in load bearing walls may use floor dead loads with the appropriate load combination to offset uplift forces in the StiffWall
- Walls must stack vertically from top floor of structure to anchorage point or foundation
- Shear walls may overlap when the available wall space has been depleted

StiffWall® Benefits That Add Value



- Templates are not required for hold-downs, eliminating unrealistic field procedures.
- Designed and manufactured to meet the performance requirements of the project.
- Satisfies maximum story drift requirements per IBC.
- Only mill certified high strength steel is used.
- Plywood sheathing with fastener schedules and/or CMU shear walls are eliminated.
- Inspection is limited to simple connections at corners.
- Exceeds industry standards for sizes and loads.
- Versatile design may be incorporated into steel, concrete and wood construction
- Tested for multi-story application and capable of carrying loads present in 10 story buildings.
- No welds or controlled inspections associated with welding.
- Simplified anchoring system through floors and at roof termination.
- Each component is selected to meet or exceed both strength and stiffness requirements of the applicable building code.
- The strap system is on the outside of the wall to facilitate electrical and pipe work in the wall cavity.
- Allows 3 times the window space of plywood braced structures.

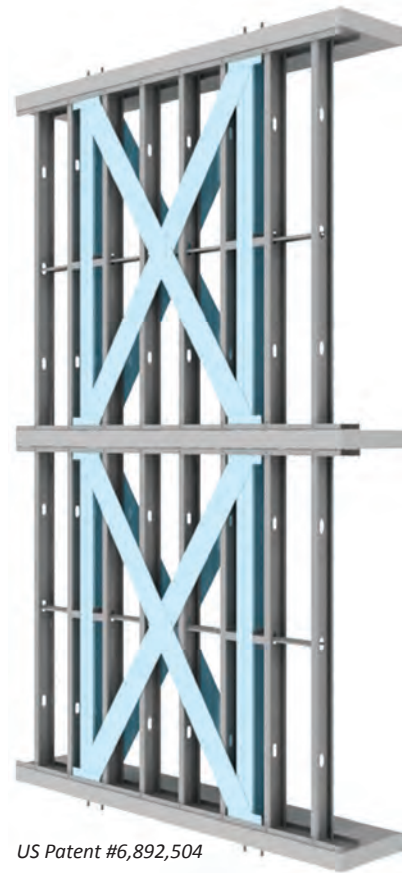

US Patent #6,892,504

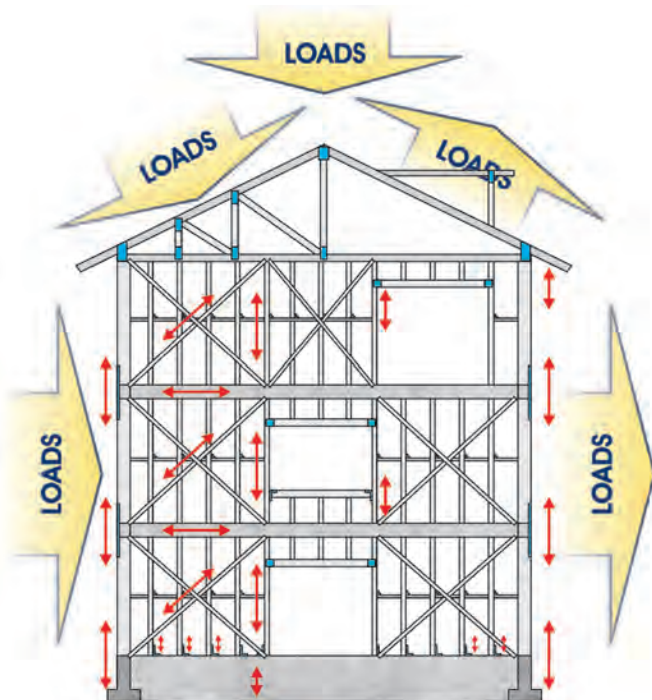

Verifying Load Paths

Tracing and verifying load paths through a structure is crucial to protect engineering liability. Loads need to migrate from the roof, through the wall and floor systems, and terminate in the foundation. Shear wall systems transfer lateral loads from the member above (i.e. floor slab) to the member below (i.e. foundation). StiffWall® provides a traceable, easily verifiable load path through the structure.

- A** Load transfers from the floor above through the floor connector, and to the StiffWall Boot
 - B** From the Boot to the Strap Track*
 - C** From the Strap Track to the flat strap*
 - D** Through the flat strap to the Strap Track at opposite corner*
 - E** From the Strap Track to the Boot
 - F** From the Boot to the floor/system or foundation below
- * The column section assumes the compression loads.
 * Uplift forces are transferred through the StiffWall Boot through full bearing onto the SWS Boot Base Plate to the anchor.

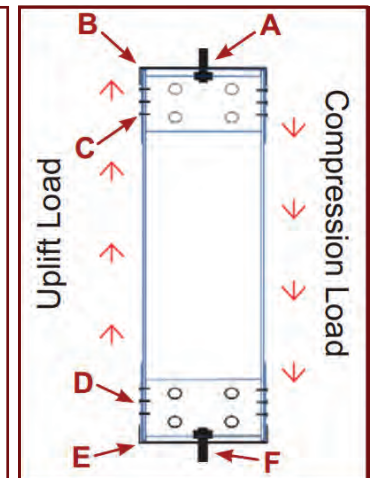

Simple Steps to Design Shear Walls

The following pages offer a guide for the design of the StiffWall® shear wall system. In addition, SteelSmart® System software is available (at www.steelSMARTsystem.com) to select the optimal column, boot, strap and fasteners used in the installation of StiffWall. Contact The Steel Network for additional design information.

Step 1 - Select StiffWall® Column

This unique column contains an additional return lip to form a double lip, thus creating a stronger, more effective bearing section. The column is the main vertical load-bearing transfer element in StiffWall.

Important Note:

The StiffWall Boot must be used with the StiffWall Column. Standard stud (S) sections will not fit inside the StiffWall Boot or Strap Track.

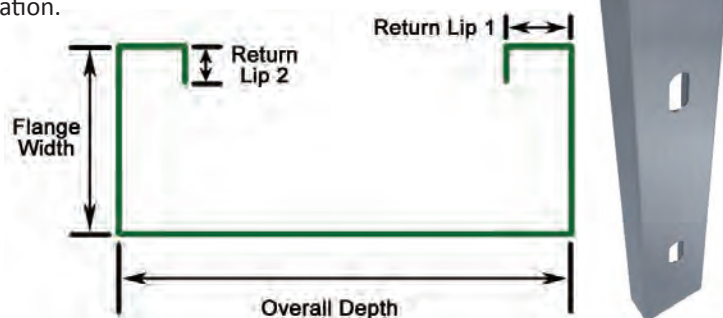

Step 2 - Select StiffWall® Boot

The StiffWall Boot is a critical element enabling StiffWall to simultaneously resist higher loads and provide positive load transfer between elements, something conventional shear wall systems do not provide. Six different StiffWall Boots are available for accommodating changing loading requirements. Refer to the Boot Capacities table data to select the appropriate Boot to fit project conditions.

Step 3 - Determine Column-To-Boot Uplift Fastener Requirement

Attaching to the StiffWall Column with #12 screws or 0.5" A325 bolts, the boot enhances construction efficiency by reducing the number of installed fasteners used in conventional flat strap shear walls. For uplift conditions, calculate the number of screws for the Light and Plus Boots by dividing the total uplift force by the single screw shear. For Small, Medium, Transition, and Large Boots, refer to the chart below for the number of fasteners to the column.

Single Column Allowable Uplift Load (T2) (kips)																	
Column Thickness		Light / Plus Boot	Small Boot			Medium / Transition Boot						Large Boot					
			350, 362 & 400	550 & 600	800	350, 362 & 400			550 & 600	800	550 & 600	800	350, 362 & 400	550 & 600	800		
(mils)	(inch)	(1) # 12 Screw	(2) Bolts	(4) Bolts	(3) Bolts	(4) Bolts	(5) Bolts	(6) Bolts	(8) Bolts	(10) Bolts	(7) Bolts	(14) Bolts					
33	0.0346	0.27	1.71	3.43	3.43	2.57	3.43	4.13	5.14	5.14	6.85	6.85	7.50	8.56	5.27	9.78	11.30
43	0.0451	0.41	2.30	4.59	4.59	3.45	4.59	5.38	6.89	6.89	9.19	9.19	9.77	11.48	6.87	12.74	14.72
54	0.0566	0.57	2.97	5.94	5.94	4.46	5.94	6.75	8.91	8.91	11.88	11.88	12.26	14.75	8.62	15.99	18.48
68	0.0713	0.78	3.88	7.77	7.77	5.83	7.77	8.51	11.65	11.65	15.54	15.54	15.45	18.58	10.86	20.15	23.28
97	0.1017	0.78	5.96	11.92	11.92	8.94	11.92	12.13	17.88	17.88	23.84	23.84	22.04	26.50	15.48	28.73	33.20
118	0.1242	0.78	7.66	14.64	15.32	11.49	15.32	14.82	22.98	22.98	29.36	30.64	26.91	32.36	18.91	35.09	40.55
Back-to-Back and Built-Up Column Allowable Uplift Load (T2) (kips)																	
Column Thickness		Light / Plus Boot	Small Boot			Medium / Transition Boot						Large Boot					
			350, 362 & 400	550 & 600	800	350, 362 & 400			550 & 600	800	550 & 600	800	550 & 600	800	350, 362 & 400	550 & 600	800
(mils)	(inch)	(1) # 12 Screw	(2) Bolts	(4) Bolts	(3) Bolts	(4) Bolts	(5) Bolts	(6) Bolts	(8) Bolts	(10) Bolts	(7) Bolts	(14) Bolts					
33	0.0346	N / A	3.43	6.85	6.85	5.14	6.85	8.26	10.28	10.28	13.70	13.70	14.99	17.13	10.54	19.55	22.59
43	0.0451	N / A	4.59	9.19	9.19	6.89	9.19	10.76	13.78	13.78	18.37	18.37	19.54	22.97	13.73	25.49	29.45
54	0.0566	N / A	5.94	11.88	11.88	8.91	11.88	13.51	17.82	17.82	23.77	23.77	24.53	29.50	17.23	31.98	36.96
68	0.0713	N / A	7.77	15.54	15.54	11.65	15.54	17.01	23.31	23.31	31.08	31.08	30.90	37.16	21.71	40.29	46.55
97	0.1017	N / A	10.60	21.21	21.21	15.90	21.21	24.27	31.81	31.81	42.41	42.41	44.07	53.00	30.97	57.47	66.40
118	0.1242	N / A	10.60	21.21	21.21	15.90	21.21	26.51	31.81	31.81	42.41	42.41	53.01	53.01	37.11	70.18	74.22

- Bolts referenced in table are ASTM F3125 Grade A325.
- Refer to the Design Example for uplift requirements.
- Allowable loads for screws are based on AISI S100 Specification, Section E4.3.
- Maximum allowable load per (1) #12 screw in shear is equal to 0.849 kips, based on commercial screw data.
- Allowable loads for bolts are based on AISI S100, Section E3.3.2.
- Maximum allowable load per (1) A325 bolt in shear is equal to 4.42 kips, based on AISI S100, Section E3.4.
- * Compression loads are transferred via full column bearing onto boot.

Step 4 - Select Stiffwall® Flat Strap

Flat strap is the tension element used to transfer loads between diagonally located strap tracks. Flat strap selection is simplified to 5 strap types (see chart below), with load capacity factored using standard 12ga (97mils) strap track.

Strap Width	Strap Thickness	Yield Strength	Recommended # of screws/ row	Allowable Tension in Single Strap	No. of #12 Screws for Max. Strap Tension
(in)	(mil)	(ksi)	(#)	(kips)	# (kips)
4	54	50	4	5.77	11 (6.26)
6	54		6	8.65	16 (9.10)
8	54		8	11.54	21 (11.95)
8	68		8	14.53	19 (14.76)
10	68		10	18.17	24 (18.65)

- Screw shear values are based on #12 (0.216") screw attached to 97 mil (12 ga) Strap Track.
- Minimum screw spacing = 3d
- Minimum screw edge distance = 1.5d

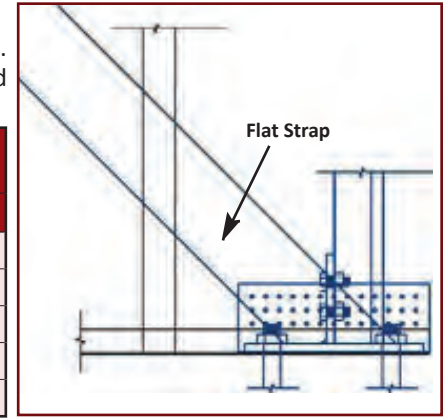

It is recommended to limit the use of 10" flat strap to shear wall panels that have aspect ratio > 0.72:1 (36 degrees)

Step 5 - Condition 1: Anchor Design At Foundation

Refer to Section 3.1.8 in the Hilti North American Product Technical Guide Volume 2, to design anchors at the foundation. For typical details of StiffWall at foundation, see Example Details provided in this catalog. TSN recommends the use of a washer, lock washer, double-nut washer, or tack weld at each end of the bolt.

Allowable Tension and Shear Values of Hilti HIT-RE 500 Adhesive Anchors							
Anchor Diameter	Embedment Depth	Tension			Shear (Non Seismic Design)		
		Based on Bond or Concrete		Based on Steel Strength	Based on Bond or Concrete		Based on Steel Strength
		f'c = 2000 psi	f'c = 4000 psi	ASTM A193 B7	f'c = 2000 psi	f'c = 4000 psi	ASTM A193 B7
(in)	(in)	(lb)	(lb)	(lb)	(lb)	(lb)	(lb)
¾"	4	3,005	5,665	24,805	7,795	11,020	12,780
	7 ⅞	12,495	15,875		17,175	24,290	
	10 ½	14,705	16,185		26,440	37,390	
1 ¼"	5 ⅝	5,760	12,815	50,620	14,760	20,870	26,080
	11 ¼	24,610	31,620		35,050	49,570	

- Bond, concrete, and steel values are referenced from Hilti North American Product Technical Guide Volume 2.
- Apply influence factors for spacing and/or edge distance to concrete/bond values, then compare to the steel strength value. The lesser value is to be used for design.
- Applied tension force shall include tension resulting from prying action produced by deformation of connected parts.
- For design of anchorage under seismic conditions, refer to ACI 318 Appendix D - Anchoring to Concrete provisions.

Step 5 - Condition 2: Through Floor Fastener Connection

Refer to Section J3.4 in the AISI S100-16 Spec to design through floor bolt fasteners. For typical details of StiffWall at foundation, see Example Details provided in this catalog. TSN recommends the use of a washer, lock washer, double-nut washer, or tack weld at each end of the bolt. For typical details of StiffWall at top termination (roof) and through floors, see Example Details provided in this catalog.

Fastening StiffWall® Boot Through Floor		
Allowable Shear and Tension		
Shear Stress (F _v) for A325 Threads (ksi)	Tension Stress (F _t) (ksi)	Combined Shear (F _v) and Tension (F _t)
27.0	45.0	Section J3.4, AISI S100-16 Spec.

- Ensure full bearing between through-floor bolts and the floor slab. Enlarged or notched bolt holes in the slab must be filled with grout.
- Applied tension force shall include tension resulting from prying action produced by deformation of the connected parts.
- The area of a ¾" bolt = 0.60 in² and area of 1 ¼" bolt = 1.23 in².
- Allowable Shear per one ¾" A325 Bolt = 16.2 kips.
- Allowable Shear per one 1 ¼" A325 Bolt = 33.2 kips.
- Allowable Tension per one ¾" A325 Bolt = 27.0 kips.
- Allowable Tension per one 1 ¼" A325 Bolt = 55.4 kips.
- **Boot base plate guide holes for wall widths less than 5.5" accommodate ¾" through-rods for Light, Plus, Small, Medium, and Large Boots.**
- **Boot base plate guide holes for wall widths greater than or equal to 5.5" accommodate ¾" through-rods for Light, Plus, Small, and Medium Boots. For Large Boots, the base plate guide holes accommodate 1 ¼" through-rods. To transition from a Large Boot with 1 ¼" through rods to any other boot type, a Transition Boot Kit is required, which will accommodate 1 ¼" through-rods on the base of wall, and ¾" through rods at the head of the wall.**

Shear Wall Systems

Pre-Assembled Columns/Boots

Order Information

StiffWalls consist of two Column/Boot Assemblies (at each end post) and Flat Strap (2 sides of X-bracing). The StiffWall fits into or is embedded into the load bearing and non-load bearing walls. Do your stud take off as normal and order the Column/Boot Assembly and the Flat Strap as separate items. When ordering columns, determine the height of the bearing wall. TSN will size the StiffWall Column/Boot Assembly factoring in the dimensions of the boots at top and bottom as shown in the image to the right.

The added value of the pre-installed boots minimizes tolerance issues during erection. Simply specify the clear span of the bearing wall system and TSN will ship the Column/Boot assembly to meet the given wall height at a tolerance of +0/-1/8".

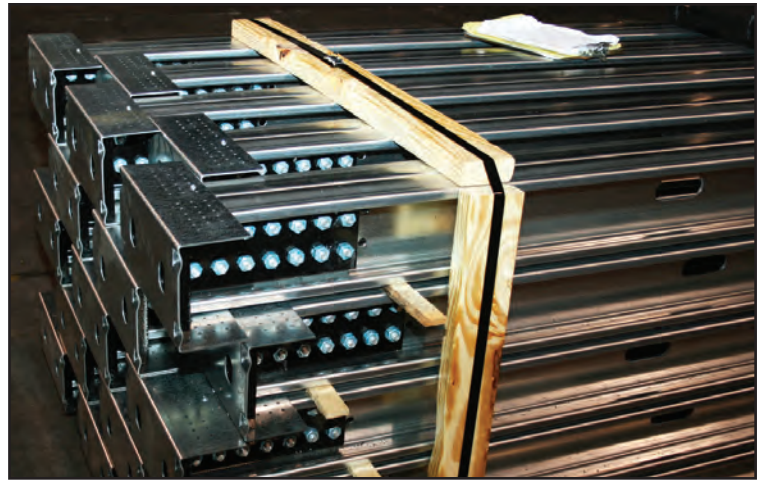

Nomenclature

600C/STW250-68-1-SM-10ft-9-1/4"

Overall Depth
Ex: 600 = 6" Wall Framing

Flange Width
Ex: 250 = 2.5" Column Flange

of Column Pieces
(1, 2, 3, 4 or 5)

Boot Type
LT = Light Boot
PL = Plus Boot
SM = Small Boot
ME = Medium Boot
TR = Transition Boot
LG = Large Boot

Clear Span of Bearing Wall
Provide the height of the wall span (same as the height of the load bearing wall studs). Distance is given feet + fractions of inches.

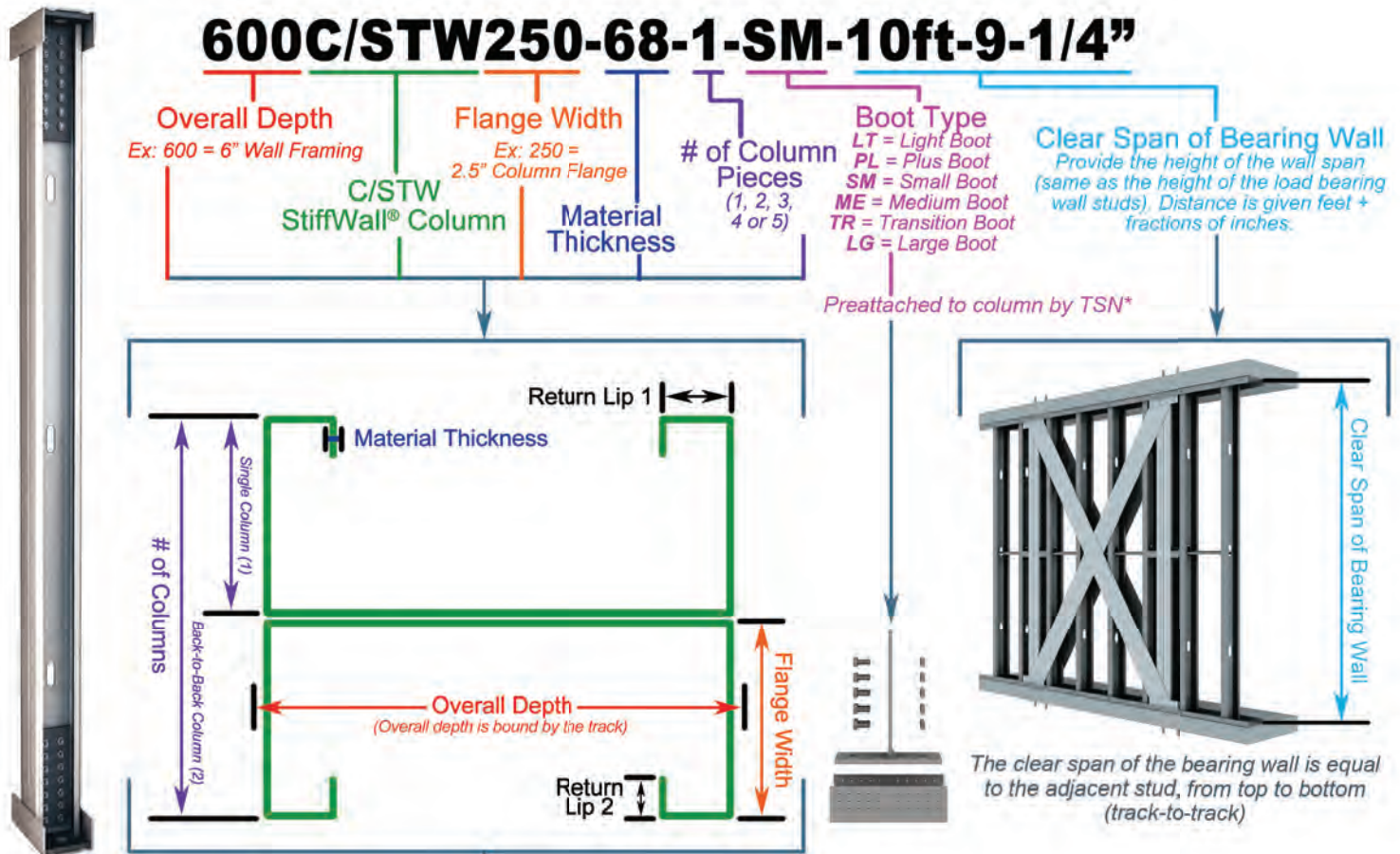

Built-up Columns (3, 4 or 5)

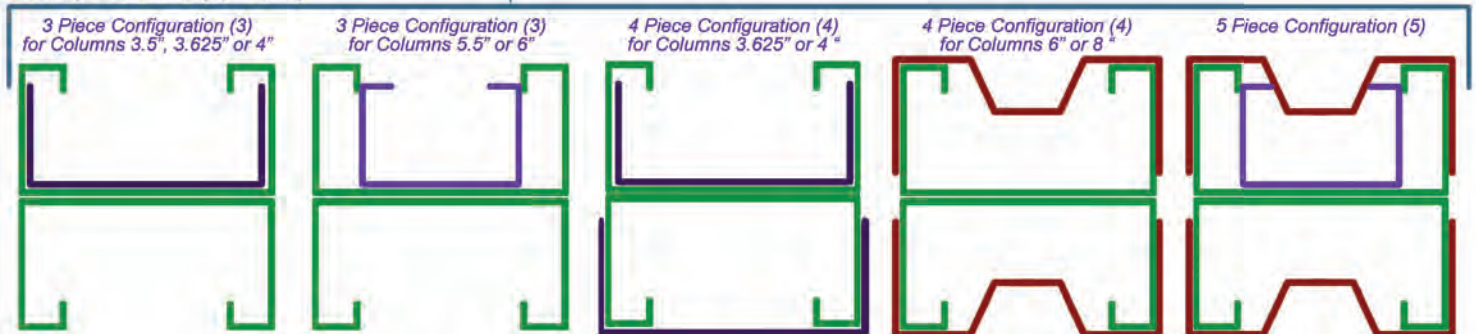

Shear Wall Systems Single & Back-to-Back StiffWall® Column Product Profile

600C/STW250-68

Overall Depth
 C/STW
 StiffWall® Column
 Flange Width
 Material Thickness

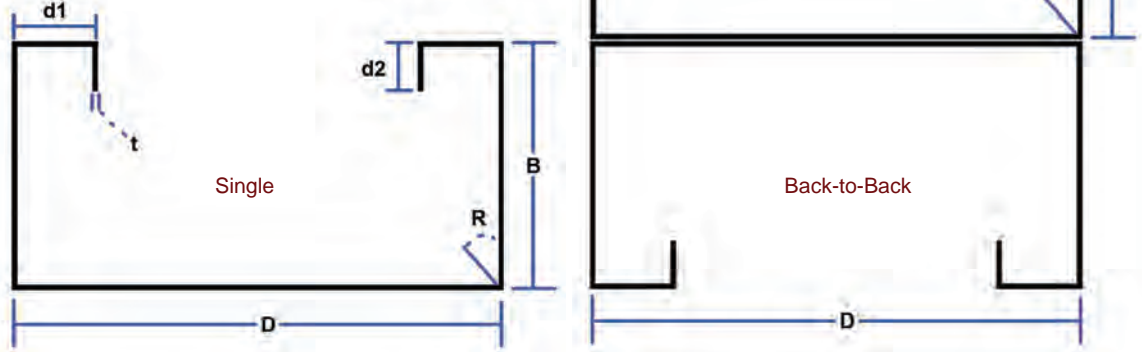

Material Properties

ASTM A1003/A1003M or ASTM A653/A653M, Grade 50 (340), 50ksi (340MPa) minimum yield strength, 65ksi (450 MPa) minimum tensile strength, G-60 (Z180) hot-dipped galvanized coating; or equivalent.

Single & Back-to-Back StiffWall® Column Product Profile

Section (All 50 ksi)	Overall Depth	Flange Width	Return Lip 1	Return Lip 2	Inside Bend Radius	Design Thickness	Unit Weight
	D (in)	B (in)	d1 (in)	d2 (in)	R (in)	t (in)	(lbs/ft)
350C/STW200-33	3.139	2.000	0.5892	0.5	0.105	0.0346	1.035
350C/STW200-43	3.139	2.000	0.6102	0.5	0.105	0.0451	1.344
350C/STW200-54	3.139	2.000	0.6332	0.5	0.105	0.0566	1.680
350C/STW200-68	3.139	2.000	0.6626	0.5	0.105	0.0713	2.104
350C/STW200-97	3.139	2.000	0.7234	0.5	0.105	0.1017	2.967
350C/STW200-118	3.139	2.000	0.7684	0.5	0.105	0.1242	3.587
362C/STW200-33	3.264	2.000	0.5892	0.5	0.105	0.0346	1.050
362C/STW200-43	3.264	2.000	0.6102	0.5	0.105	0.0451	1.364
362C/STW200-54	3.264	2.000	0.6332	0.5	0.105	0.0566	1.704
362C/STW200-68	3.264	2.000	0.6626	0.5	0.105	0.0713	2.135
362C/STW200-97	3.264	2.000	0.7234	0.5	0.105	0.1017	3.010
362C/STW200-118	3.264	2.000	0.7684	0.5	0.105	0.1242	3.639
400C/STW200-33	3.639	2.000	0.5892	0.5	0.105	0.0346	1.094
400C/STW200-43	3.639	2.000	0.6102	0.5	0.105	0.0451	1.421
400C/STW200-54	3.639	2.000	0.6332	0.5	0.105	0.0566	1.776
400C/STW200-68	3.639	2.000	0.6626	0.5	0.105	0.0713	2.226
400C/STW200-97	3.639	2.000	0.7234	0.5	0.105	0.1017	3.140
400C/STW200-118	3.639	2.000	0.7684	0.5	0.105	0.1242	3.798
550C/STW250-43	5.139	2.500	0.6102	0.5	0.105	0.0451	1.805
550C/STW250-54	5.139	2.500	0.6332	0.5	0.105	0.0566	2.258
550C/STW250-68	5.139	2.500	0.6626	0.5	0.105	0.0713	2.832
550C/STW250-97	5.139	2.500	0.7234	0.5	0.105	0.1017	4.005
550C/STW250-118	5.139	2.500	0.7684	0.5	0.105	0.1242	4.853
600C/STW250-43	5.639	2.500	0.6102	0.5	0.105	0.0451	1.882
600C/STW250-54	5.639	2.500	0.6332	0.5	0.105	0.0566	2.354
600C/STW250-68	5.639	2.500	0.6626	0.5	0.105	0.0713	2.954
600C/STW250-97	5.639	2.500	0.7234	0.5	0.105	0.1017	4.178
600C/STW250-118	5.639	2.500	0.7684	0.5	0.105	0.1242	5.064
800C/STW250-43	7.639	2.500	0.6102	0.5	0.105	0.0451	2.189
800C/STW250-54	7.639	2.500	0.6332	0.5	0.105	0.0566	2.739
800C/STW250-68	7.639	2.500	0.6626	0.5	0.105	0.0713	3.439
800C/STW250-97	7.639	2.500	0.7234	0.5	0.105	0.1017	4.871
800C/STW250-118	7.639	2.500	0.7684	0.5	0.105	0.1242	5.908

Standard (S) section studs will not fit in the StiffWall® Boot and should not be considered as a substitute for the StiffWall Column.

Material Properties

ASTM A1003/A1003M or ASTM A653/A653M, Grade 50 (340), 50ksi (340MPa) minimum yield strength, 65ksi (450 MPa) minimum tensile strength, G-60 (Z180) hot-dipped galvanized coating; or equivalent.

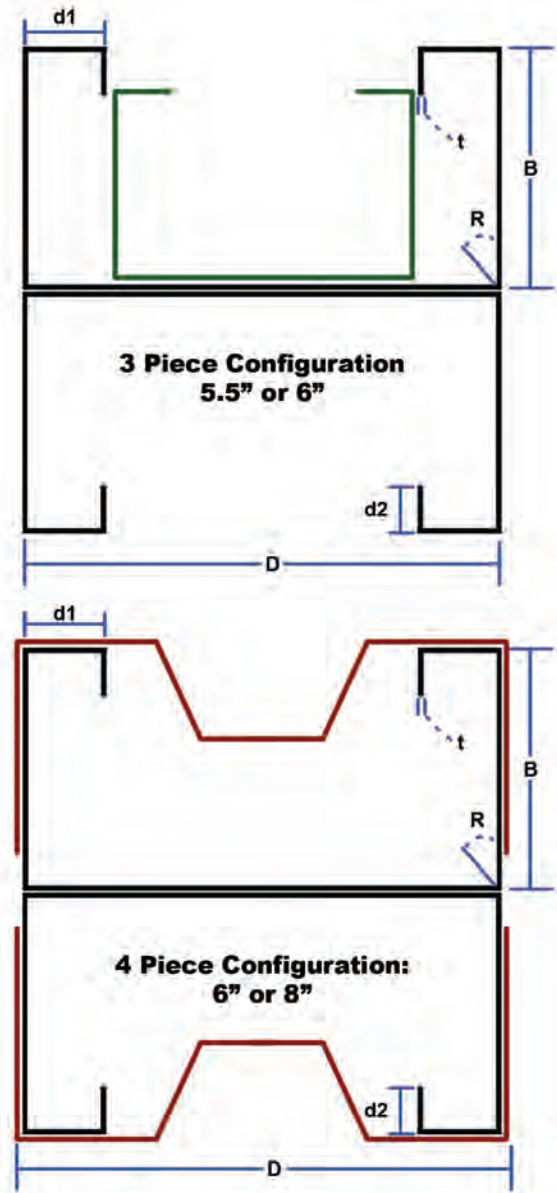
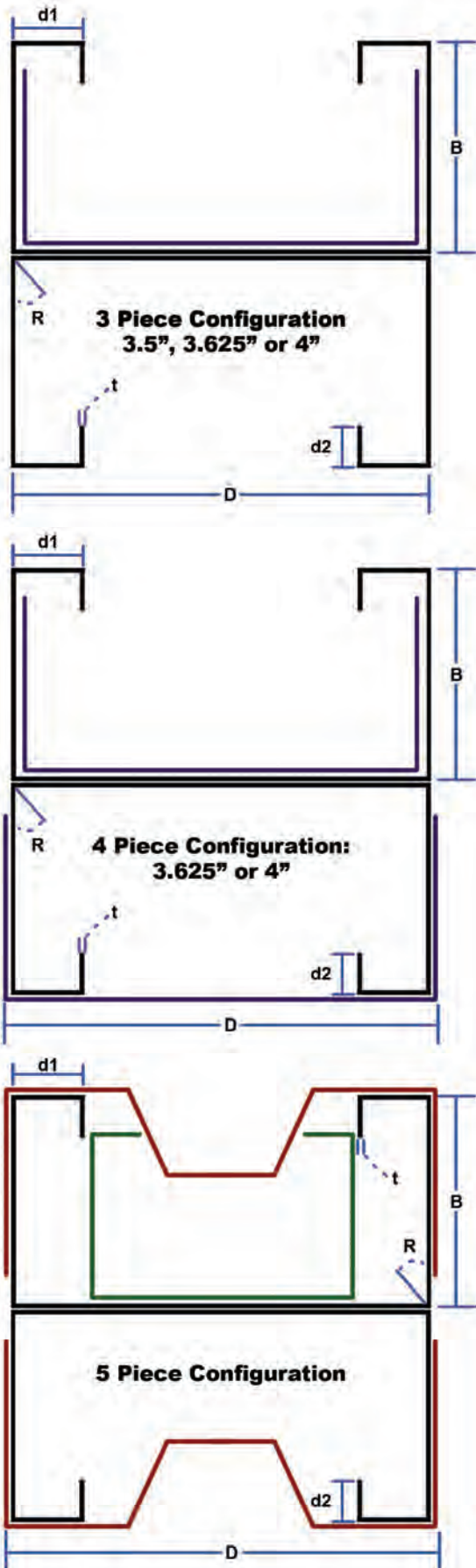

StiffWall® Column (C/STW)

- Back-to-Back (C/STW)**
- Standard Stud (S)**
- Sigma Piece (SGP)**
- Track (T)**

Built-Up StiffWall® Column Product Profile							
Depth (in)	Section (All 50 ksi)	Components	Overall Depth	Flange Width	Return Lip 1	Design Thickness	Unit Weight
			D	B	d1	t	(lbs/ft)
			(in)	(in)	(in)	(in)	
350	(3P) 350C/STW200-97	(2) 350C/STW200-97	3.139	2.000	0.7234	0.1017	7.793
		275T150-97	2.750	1.500	N/A	0.1017	
	(3P) 350C/STW200-118	(2) 350C/STW200-118	3.139	2.000	0.7684	0.1242	9.032
		275T150-97	2.750	1.500	N/A	0.1017	
362	(3P) 362C/STW200-97	(2) 362C/STW200-97	3.264	2.000	0.7234	0.1017	7.880
		275T150-97	2.750	1.500	N/A	0.1017	
	(3P) 362C/STW200-118	(2) 362C/STW200-118	3.264	2.000	0.7684	0.1242	9.138
		275T150-97	2.750	1.500	N/A	0.1017	
	(4P) 362C/STW200-97	(2) 362*C/STW200-97	3.029	2.000	0.7234	0.1017	9.841
		275T150-97	2.750	1.500	N/A	0.1017	
		326T162-97	3.264	1.625	N/A	0.1017	
	(4P) 362C/STW200-118	(2) 362*C/STW200-118	3.029	2.000	0.7684	0.1242	11.156
		275T150-97	2.750	1.500	N/A	0.1017	
		326T162-97	3.264	1.625	N/A	0.1017	
400	(3P) 400C/STW200-97	(2) 400C/STW200-97	3.639	2.000	0.7234	0.1017	8.139
		275T150-97	2.750	1.500	N/A	0.1017	
	(3P) 400C/STW200-118	(2) 400C/STW200-118	3.639	2.000	0.7684	0.1242	9.454
		275T150-97	2.750	1.500	N/A	0.1017	
	(4P) 400C/STW200-97	(2) 400*C/STW200-97	3.404	2.000	0.7234	0.1017	10.230
		275T150-97	2.750	1.500	N/A	0.1017	
		364T162-97	3.639	1.625	N/A	0.1017	
	(4P) 400C/STW200-118	(2) 400*C/STW200-118	3.404	2.000	0.7684	0.1242	11.509
275T150-97		2.750	1.500	N/A	0.1017		
364T162-97		3.639	1.625	N/A	0.1017		
550	(3P) 550C/STW250-97	(2) 550C/STW250-97	5.139	2.500	0.7234	0.1017	10.604
		400S162-97	4.000	1.625	0.5000	0.1017	
	(3P) 550C/STW250-118	(2) 550C/STW250-118	5.139	2.500	0.7684	0.1242	12.299
		400S162-97	4.000	1.625	0.5000	0.1017	

* Overall Depth (D) varies from Single and Back-to-Back sections

Built-Up StiffWall® Column Product Profile

Built-Up StiffWall® Column Product Profile							
Depth (in)	Section (All 50 ksi)	Components	Overall Depth	Flange Width	Return Lip 1	Design Thickness	Unit Weight
			D	B	d1	t	(lbs/ft)
			(in)	(in)	(in)	(in)	
600	(3P) 600C/STW250-97	(2) 600C/STW250-97	5.639	2.500	0.7234	0.1017	10.950
		400S162-97	4.000	1.625	0.5000	0.1017	
	(3P) 600C/STW250-118	(2) 600C/STW250-118	5.639	2.500	0.7684	0.1242	12.721
		400S162-97	4.000	1.625	0.5000	0.1017	
	(4P) 600C/STW250-97	(2) 600*C/STW250-97	5.404	2.500	0.7234	0.1017	15.704
		(2) 564SGP225-97	5.639	2.250	N/A	0.1017	
	(4P) 600C/STW250-118	(2) 600*C/STW250-118	5.404	2.500	0.7684	0.1242	17.439
		(2) 564SGP225-97	5.639	2.250	N/A	0.1017	
	(5P) 600C/STW250-97	(2) 600*C/STW250-97	5.404	2.500	0.7234	0.1017	18.297
		(2) 564SGP225-97	5.639	2.250	N/A	0.1017	
		400S162-97	4.000	1.625	0.5000	0.1017	
	(5P) 600C/STW250-118	(2) 600*C/STW250-118	5.404	2.500	0.7684	0.1242	20.032
(2) 564SGP225-97		5.639	2.250	N/A	0.1017		
400S162-97		4.000	1.625	0.5000	0.1017		
800	(3P) 800C/STW250-97	(2) 800C/STW250-97	7.639	2.500	0.7234	0.1017	13.373
		600S200-97	6.000	2.000	0.6250	0.1017	
	(3P) 800C/STW250-118	(2) 800C/STW250-118	7.639	2.500	0.7684	0.1242	15.447
		600S200-97	6.000	2.000	0.6250	0.1017	
	(4P) 800C/STW250-97	(2) 800*C/STW250-97	7.404	2.500	0.7234	0.1017	18.473
		(2) 764SGP225-97	7.639	2.250	N/A	0.1017	
	(4P) 800C/STW250-118	(2) 800*C/STW250-118	7.404	2.500	0.7684	0.1242	20.511
		(2) 764SGP225-97	7.639	2.250	N/A	0.1017	
	(5P) 800C/STW250-97	(2) 800*C/STW250-97	7.404	2.500	0.7234	0.1017	21.758
		(2) 764SGP225-97	7.639	2.250	N/A	0.1017	
		600S162-97	6.000	1.625	0.5000	0.1017	
	(5P) 800C/STW250-118	(2) 800*C/STW250-118	7.404	2.500	0.7684	0.1242	23.797
(2) 764SGP225-97		7.639	2.250	N/A	0.1017		
600S162-97		6.000	1.625	0.5000	0.1017		

* Overall Depth (D) varies from Single and Back-to-Back sections

Important Notes

1. Calculated properties are based on AISI S100-16 Spec, "North American Specification for the Design of Cold-Formed Steel Structural Members".
2. Effective properties incorporate the strength increase from the cold-work of forming as applicable per AISI S100-16 Spec, Sec. A3.3.2 (3).
3. Tabulated gross properties are based on the full-unreduced cross section of the studs, away from punchouts.
4. Net effective section properties are calculated at a cross section through the punchout.
5. Allowable moment is the lesser of M_{al} and M_{ad} . Stud distortional buckling is based on an assumed $k_{\phi} = 0$.
6. For deflection calculations, use the effective moment of inertia.
7. The effective moment of inertia for deflection is calculated at a stress which results in a section modulus such that the stress times the section modulus at that stress is equal to the allowable moment. AISI S100-16 Procedure I for Serviceability Determination has been used. Increases in the effective moment of inertia (I_{xe}) may be possible at lower stress levels. Any modified values would be required to be calculated by a qualified engineer.
8. The StiffWall Column must be used with the StiffWall Boot. Standard (S) sections will not fit inside the StiffWall Boot or Strap Track.



Single StiffWall® Column Section Properties																					
Section (All 50 ksi)	Gross Properties						Effective Properties 50 ksi						Torsional Properties						L_u (in)		
	Area	I_x	S_x	R_x	I_y	R_y	I_{xe}	S_{xe}	M_{al}	M_{ad}	$M_{ad(net)}$	V_a	$V_{a(net)}$	$J \times 10^3$	C_w	X_o	m	R_o		β	
	(in ²)	(in ⁴)	(in ³)	(in)	(in ⁴)	(in)	(in ⁴)	(in ³)	(in-k)	(in-k)	(in-k)	(lb)	(lb)	(in ⁴)	(in ⁶)	(in)	(in)	(in)			
350C/STW200-33	0.304	0.489	0.312	1.268	0.185	0.781	0.477	0.267	8.005	7.569	7.355	1,260	459	0.121	0.607	-2.038	1.209	2.524	0.348	47.71	
350C/STW200-43	0.395	0.629	0.401	1.262	0.239	0.777	0.629	0.371	11.115	10.720	10.407	2,141	589	0.268	0.787	-2.032	1.206	2.515	0.347	47.98	
350C/STW200-54	0.494	0.777	0.495	1.255	0.295	0.774	0.777	0.476	14.240	14.297	13.882	2,988	643	0.527	0.982	-2.026	1.203	2.506	0.346	48.31	
350C/STW200-68	0.618	0.960	0.612	1.246	0.366	0.769	0.960	0.612	20.298	20.298	19.479	3,725	622	1.048	1.226	-2.018	1.199	2.493	0.345	48.82	
350C/STW200-97	0.872	1.315	0.838	1.228	0.502	0.759	1.315	0.838	28.703	28.703	28.079	5,197	580	3.006	1.718	-2.001	1.190	2.467	0.342	50.15	
350C/STW200-118	1.054	1.555	0.991	1.215	0.595	0.752	1.555	0.991	34.727	34.727	33.948	6,233	577	5.402	2.065	-1.988	1.183	2.448	0.341	51.40	
362C/STW200-33	0.309	0.535	0.328	1.317	0.188	0.781	0.523	0.282	8.446	7.915	7.692	1,235	491	0.123	0.644	-2.016	1.198	2.531	0.366	47.36	
362C/STW200-43	0.401	0.689	0.422	1.311	0.242	0.778	0.689	0.391	11.717	11.222	10.896	2,141	644	0.272	0.834	-2.010	1.195	2.523	0.365	47.60	
362C/STW200-54	0.501	0.852	0.522	1.304	0.300	0.774	0.852	0.501	15.003	14.986	14.551	3,121	736	0.535	1.040	-2.004	1.192	2.513	0.364	47.90	
362C/STW200-68	0.627	1.053	0.645	1.295	0.371	0.769	1.053	0.645	21.404	21.404	20.565	3,892	713	1.063	1.299	-1.996	1.188	2.501	0.363	48.36	
362C/STW200-97	0.885	1.443	0.884	1.277	0.510	0.760	1.443	0.884	30.305	30.305	29.704	5,436	668	3.050	1.817	-1.979	1.179	2.475	0.361	49.58	
362C/STW200-118	1.069	1.709	1.047	1.264	0.605	0.752	1.709	1.047	36.699	36.699	35.950	6,524	636	5.481	2.183	-1.966	1.172	2.455	0.359	50.73	
400C/STW200-33	0.322	0.689	0.379	1.464	0.197	0.782	0.674	0.328	9.806	8.958	8.711	1,097	546	0.128	0.764	-1.952	1.167	2.562	0.420	46.47	
400C/STW200-43	0.418	0.887	0.488	1.458	0.253	0.779	0.887	0.453	13.574	12.742	12.376	2,141	808	0.283	0.989	-1.946	1.164	2.553	0.419	46.65	
400C/STW200-54	0.522	1.099	0.604	1.451	0.314	0.775	1.099	0.579	17.350	17.072	16.581	3,372	1002	0.557	1.232	-1.940	1.161	2.544	0.418	46.88	
400C/STW200-68	0.654	1.360	0.748	1.442	0.388	0.770	1.360	0.748	24.808	24.516	21.768	4,394	1019	1.108	1.536	-1.932	1.157	2.531	0.417	47.23	
400C/STW200-97	0.923	1.871	1.028	1.424	0.534	0.761	1.871	1.028	35.237	35.237	34.699	6,151	966	3.181	2.143	-1.915	1.149	2.505	0.415	48.18	
400C/STW200-118	1.116	2.220	1.220	1.411	0.633	0.753	2.220	1.220	42.775	42.775	42.103	7,396	928	5.719	2.569	-1.903	1.142	2.485	0.414	49.07	
550C/STW250-43	0.530	2.281	0.888	2.074	0.491	0.962	2.263	0.748	22.395	19.964	19.452	1,687	1156	0.360	3.069	-2.203	1.321	3.175	0.518	54.01	
550C/STW250-54	0.663	2.835	1.103	2.067	0.609	0.958	2.835	0.952	28.495	27.219	26.494	3,350	1817	0.708	3.821	-2.197	1.318	3.165	0.518	54.12	
550C/STW250-68	0.832	3.527	1.373	2.059	0.757	0.954	3.527	1.240	37.123	37.025	36.026	5,352	2284	1.410	4.763	-2.189	1.314	3.153	0.518	54.30	
550C/STW250-97	1.177	4.902	1.908	2.041	1.050	0.944	4.902	1.873	62.630	63.109	61.411	9,011	2646	4.058	6.644	-2.173	1.306	3.127	0.517	54.79	
550C/STW250-118	1.426	5.864	2.282	2.028	1.253	0.937	5.864	2.282	77.725	77.725	77.263	10,883	2585	7.308	7.966	-2.161	1.299	3.108	0.517	55.27	
600C/STW250-43	0.553	2.825	1.002	2.261	0.508	0.958	2.808	0.849	25.412	22.108	21.553	1,529	1205	0.375	3.671	-2.134	1.288	3.253	0.570	53.58	
600C/STW250-54	0.692	3.514	1.246	2.254	0.630	0.955	3.514	1.079	32.300	30.211	29.419	3,035	1895	0.739	4.568	-2.128	1.285	3.244	0.569	53.66	
600C/STW250-68	0.868	4.376	1.552	2.245	0.783	0.950	4.376	1.404	42.024	41.209	40.111	5,352	2632	1.471	5.692	-2.121	1.281	3.231	0.569	53.78	
600C/STW250-97	1.228	6.093	2.161	2.228	1.086	0.941	6.093	2.121	70.909	70.573	68.682	9,965	3380	4.233	7.932	-2.104	1.273	3.205	0.569	54.15	
600C/STW250-118	1.488	7.298	2.588	2.215	1.297	0.934	7.298	2.588	88.143	88.143	87.722	12,046	3311	7.626	9.503	-2.092	1.266	3.186	0.569	54.51	
800C/STW250-43	0.643	5.723	1.498	2.983	0.563	0.936	5.718	1.169	35.009	30.715	30.002	1,112	1112	0.436	6.814	-1.904	1.176	3.661	0.729	52.43	
800C/STW250-54	0.805	7.131	1.867	2.976	0.700	0.932	7.131	1.627	48.704	42.289	41.256	2,206	2098	0.860	8.472	-1.898	1.173	3.651	0.730	52.42	
800C/STW250-68	1.011	8.900	2.330	2.968	0.870	0.928	8.900	2.121	63.488	58.224	56.756	4,427	3326	1.712	10.544	-1.890	1.169	3.639	0.730	52.41	
800C/STW250-97	1.431	12.452	3.260	2.950	1.207	0.918	12.452	3.199	106.947	101.278	98.639	10,888	5676	4.934	14.662	-1.873	1.160	3.613	0.731	52.47	
800C/STW250-118	1.736	14.968	3.919	2.936	1.442	0.911	14.968	3.919	133.452	132.711	129.397	16,187	6867	8.897	17.540	-1.861	1.153	3.594	0.732	52.55	

Important Notes

1. Allowable loads are based on specified weak axis and torsional bracing for axial load calculation.
2. Sections are punched with a standard punch-out 1.5" wide located along the centerline of the web 24" o.c.
3. Allowable loads are based on a punched section for axial load calculation.
4. The allowable axial strength for distortional buckling is based on an assumed $k_y = 0$.
5. Weak axis and torsional bracing should have sufficient stiffness and strength to resist the axial load.
6. Strength increase due to cold work of forming is incorporated in calculating allowable loads as per AISI S100-16 Spec, Sec. A3.3.2 (3).
7. The StiffWall Column must be used with the StiffWall Boot. Standard (S) sections will not fit inside the StiffWall Boot or Strap Track.
8. StiffWall Columns are delivered to the job site with Boots pre-attached at the top and bottom for fast installation.

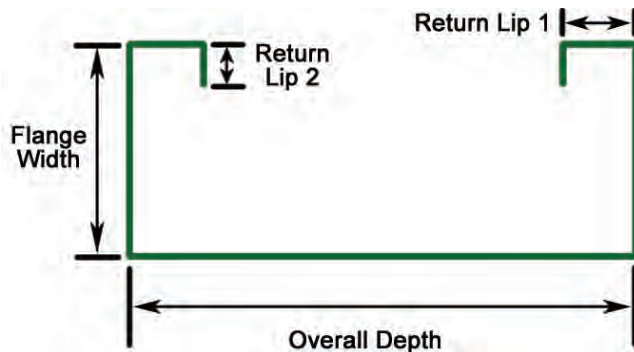

Single Section: Axial Compression Load (kips)												
Section (All 50 ksi)	Maximum Unbraced Length = 48"				Maximum Unbraced Length = 60"				Max Unbraced Length = Full Height			
	SW Column Height (ft)				SW Column Height (ft)				SW Column Height (ft)			
	9	10	12	14	9	10	12	14	9	10	12	14
350C/STW200-33	2.64	2.41	1.95	1.57	2.12	1.96	1.64	1.37	0.91	0.75	0.54	0.42
350C/STW200-43	3.56	3.18	2.53	2.03	2.80	2.57	2.14	1.78	1.25	1.04	0.76	0.60
350C/STW200-54	4.47	3.98	3.15	2.52	3.55	3.25	2.70	2.23	1.66	1.40	1.05	0.84
350C/STW200-68	5.64	5.00	3.95	3.15	4.55	4.14	3.41	2.81	2.29	1.95	1.51	1.23
350C/STW200-97	8.10	7.14	5.57	4.40	6.75	6.09	4.94	4.02	3.96	3.45	2.76	2.08
350C/STW200-118	9.95	8.72	6.74	5.30	8.51	7.62	6.09	4.91	5.53	4.83	3.35	2.46
362C/STW200-33	2.78	2.56	2.09	1.71	2.26	2.09	1.77	1.49	0.97	0.80	0.57	0.44
362C/STW200-43	3.83	3.45	2.75	2.21	3.02	2.78	2.33	1.94	1.32	1.10	0.81	0.63
362C/STW200-54	4.81	4.32	3.44	2.76	3.83	3.51	2.93	2.43	1.76	1.48	1.11	0.89
362C/STW200-68	6.06	5.44	4.30	3.44	4.90	4.47	3.71	3.06	2.42	2.06	1.59	1.30
362C/STW200-97	8.79	7.76	6.08	4.82	7.28	6.59	5.37	4.38	4.18	3.64	2.89	2.12
362C/STW200-118	10.80	9.49	7.37	5.80	9.17	8.24	6.63	5.35	5.84	4.93	3.42	2.51
400C/STW200-33	3.15	2.95	2.53	2.09	2.62	2.47	2.13	1.82	1.14	0.94	0.68	0.52
400C/STW200-43	4.44	4.12	3.42	2.81	3.61	3.36	2.89	2.46	1.56	1.29	0.94	0.73
400C/STW200-54	5.75	5.33	4.38	3.53	4.70	4.35	3.68	3.08	2.06	1.73	1.29	1.03
400C/STW200-68	7.33	6.73	5.49	4.42	6.01	5.54	4.66	3.89	2.82	2.39	1.84	1.50
400C/STW200-97	10.73	9.75	7.77	6.20	8.93	8.16	6.76	5.57	4.83	4.21	3.05	2.24
400C/STW200-118	13.21	11.94	9.43	7.49	11.28	10.23	8.36	6.83	6.42	5.20	3.61	2.65
550C/STW250-43	6.34	6.20	5.84	5.39	5.76	5.64	5.30	4.89	2.84	2.37	1.74	1.35
550C/STW250-54	8.32	8.14	7.83	7.30	7.76	7.61	7.18	6.53	3.80	3.19	2.37	1.85
550C/STW250-68	11.94	11.55	10.62	9.57	10.51	10.20	9.46	8.59	5.19	4.38	3.25	2.54
550C/STW250-97	18.21	17.59	16.15	14.50	16.18	15.68	14.50	13.12	8.40	7.11	5.43	4.41
550C/STW250-118	23.00	22.19	20.19	17.89	20.47	19.76	18.09	16.17	11.16	9.59	7.45	5.48
600C/STW250-43	6.59	6.46	6.17	5.80	6.03	5.93	5.69	5.34	3.11	2.60	1.91	1.48
600C/STW250-54	8.66	8.49	8.14	7.81	8.02	7.94	7.68	7.25	4.17	3.50	2.61	2.05
600C/STW250-68	12.38	12.18	11.48	10.55	11.20	10.95	10.32	9.57	5.70	4.81	3.63	2.87
600C/STW250-97	19.32	18.81	17.57	16.12	17.32	16.91	15.93	14.72	9.48	8.02	6.09	4.78
600C/STW250-118	24.55	23.88	22.27	20.38	22.14	21.60	20.30	18.71	12.54	10.73	7.76	5.70
800C/STW250-43	7.13	7.08	6.94	6.74	6.64	6.60	6.49	6.35	3.93	3.27	2.40	1.86
800C/STW250-54	9.44	9.37	9.17	8.90	8.76	8.71	8.56	8.36	5.25	4.40	3.27	2.56
800C/STW250-68	13.47	13.37	13.10	12.74	12.59	12.52	12.34	12.03	7.13	6.02	4.51	3.46
800C/STW250-97	21.88	21.65	21.03	20.20	19.95	19.78	19.34	18.73	11.40	9.51	6.95	5.32
800C/STW250-118	28.08	27.78	26.98	25.90	25.71	25.49	24.91	24.11	14.46	12.06	8.77	6.47

Shear Wall Systems

Back-to-Back Axial Load Tables

Important Notes

1. Allowable loads are based on specified weak axis and torsional bracing for axial load calculation.
2. Sections are punched with a standard punch-out 1.5" wide located along the centerline of the web 24" o.c.
3. Allowable loads are based on a punched section for axial load calculation.
4. The allowable axial strength for distortional buckling is based on an assumed $k_y = 0$.
5. Weak axis and torsional bracing should have sufficient stiffness and strength to resist the axial load.
6. Strength increase due to cold work of forming is incorporated in calculating allowable loads as per AISI S100-16 Spec, Sec. A3.3.2 (3).
7. Allowable loads for Back-to-Back sections are based on maximum attachment interval of 24" o.c. via weld, bolts, or screws.
8. The StiffWall Column must be used with the StiffWall Boot. Standard (S) sections will not fit inside the StiffWall Boot or Strap Track.
9. StiffWall Columns are delivered to the job site with Boots pre-attached at the top and bottom for fast installation.

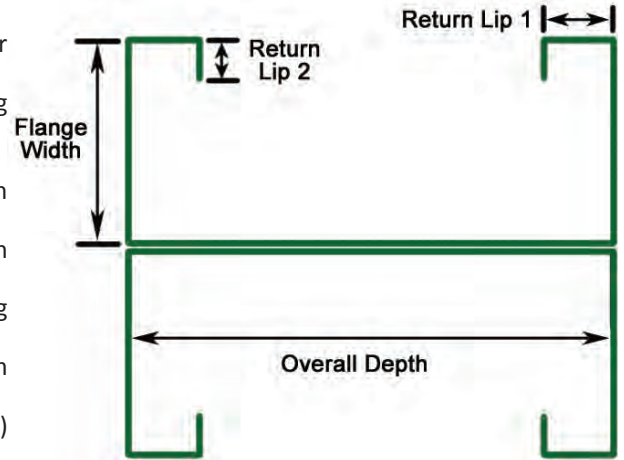

Back-to-Back (Fastener Spacing = 24 in): Axial Compression Load (kips)												
Section (Back-to-Back)	Maximum Unbraced Length = 48"				Maximum Unbraced Length = 60"				Max Unbraced Length = Full Height			
	SW Column Height (ft)				SW Column Height (ft)				SW Column Height (ft)			
	9	10	12	14	9	10	12	14	9	10	12	14
(2) 350C/STW200-33	7.40	6.71	5.34	4.06	7.40	6.71	5.34	4.06	4.51	3.76	2.73	2.10
(2) 350C/STW200-43	10.62	9.45	7.13	5.24	10.62	9.45	7.13	5.24	6.28	5.25	3.90	3.09
(2) 350C/STW200-54	13.33	11.77	8.80	6.47	13.33	11.77	8.80	6.47	8.48	7.18	5.50	4.48
(2) 350C/STW200-68	17.11	14.93	10.86	7.98	17.11	14.93	10.86	7.98	11.90	10.27	8.15	6.50
(2) 350C/STW200-97	23.89	20.68	14.84	10.90	23.89	20.68	14.84	10.90	20.21	17.12	12.21	9.11
(2) 350C/STW200-118	28.62	24.64	17.52	12.87	28.62	24.64	17.52	12.87	24.40	20.60	14.69	10.97
(2) 362C/STW200-33	7.65	7.00	5.68	4.40	7.65	7.00	5.68	4.40	4.56	3.80	2.78	2.14
(2) 362C/STW200-43	11.03	9.95	7.75	5.75	11.03	9.95	7.75	5.75	6.40	5.34	3.96	3.13
(2) 362C/STW200-54	14.11	12.57	9.62	7.11	14.11	12.57	9.62	7.11	8.62	7.29	5.56	4.52
(2) 362C/STW200-68	17.54	15.60	11.89	8.78	17.54	15.60	11.89	8.78	11.98	10.38	8.20	6.52
(2) 362C/STW200-97	25.45	22.28	16.34	12.01	25.45	22.28	16.34	12.01	20.35	17.20	12.25	9.15
(2) 362C/STW200-118	30.57	26.63	19.31	14.19	30.57	26.63	19.31	14.19	24.58	20.69	14.75	11.01
(2) 400C/STW200-33	8.29	7.72	6.53	5.35	8.29	7.72	6.53	5.35	4.66	3.89	2.87	2.24
(2) 400C/STW200-43	12.04	11.18	9.21	7.27	12.04	11.18	9.21	7.27	6.60	5.56	4.13	3.24
(2) 400C/STW200-54	15.77	14.45	11.81	9.25	15.77	14.45	11.81	9.25	9.00	7.58	5.73	4.62
(2) 400C/STW200-68	20.30	18.48	14.84	11.44	20.30	18.48	14.84	11.44	12.40	10.67	8.34	6.59
(2) 400C/STW200-97	29.85	26.83	20.96	15.70	29.85	26.83	20.96	15.70	20.76	17.41	12.39	9.24
(2) 400C/STW200-118	36.05	32.28	25.00	18.60	36.05	32.28	25.00	18.60	25.06	20.95	14.92	11.13
(2) 550C/STW250-43	14.58	14.16	13.22	12.19	13.93	13.93	13.22	12.19	9.37	8.02	5.90	4.59
(2) 550C/STW250-54	19.21	18.63	17.33	16.08	18.37	18.37	17.33	16.08	12.67	10.82	8.08	6.37
(2) 550C/STW250-68	27.22	26.38	24.66	22.40	26.12	26.12	24.66	22.40	17.18	14.93	11.35	9.12
(2) 550C/STW250-97	43.71	41.89	37.94	33.76	41.86	41.86	37.94	33.76	28.16	25.24	20.00	16.44
(2) 550C/STW250-118	54.95	52.61	47.56	42.06	53.18	52.61	47.56	42.06	37.07	33.67	27.79	20.75
(2) 600C/STW250-43	14.76	14.55	13.74	12.84	14.02	14.02	13.74	12.84	9.50	8.17	6.00	4.67
(2) 600C/STW250-54	19.48	19.20	18.08	16.83	18.50	18.50	18.08	16.83	12.85	11.00	8.19	6.45
(2) 600C/STW250-68	27.64	27.25	25.68	24.12	26.35	26.35	25.68	24.12	17.41	15.12	11.47	9.19
(2) 600C/STW250-97	44.77	43.92	40.46	36.72	42.44	42.44	40.46	36.72	28.50	25.48	20.31	16.70
(2) 600C/STW250-118	56.56	55.51	51.08	46.29	54.13	54.13	51.08	46.29	38.02	34.65	28.08	20.91
(2) 800C/STW250-43	14.77	14.77	14.77	14.41	14.20	14.20	14.20	14.20	9.77	8.45	6.19	4.79
(2) 800C/STW250-54	19.55	19.55	19.55	19.06	18.80	18.80	18.80	18.80	13.21	11.31	8.38	6.56
(2) 800C/STW250-68	27.86	27.86	27.86	27.16	26.85	26.85	26.85	26.85	17.80	15.42	11.59	9.21
(2) 800C/STW250-97	45.50	45.50	45.50	44.07	43.64	43.64	43.64	43.64	28.93	25.60	19.98	16.29
(2) 800C/STW250-118	58.13	58.13	58.13	56.36	56.12	56.12	56.12	56.12	38.52	34.63	26.92	20.83

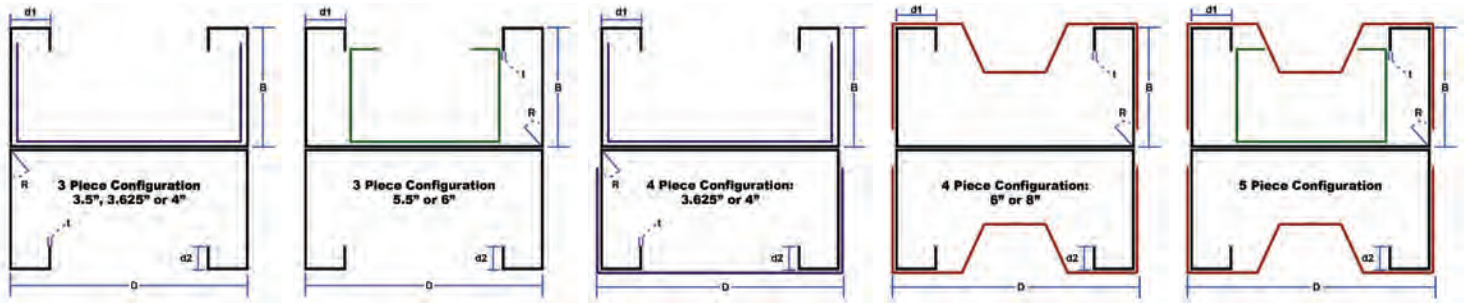

Important Notes

1. Allowable loads are based on specified weak axis and torsional bracing for axial load calculation.
2. Sections are punched with a standard punch-out 1.5" wide located along the centerline of the web 24" o.c.
3. Allowable loads are based on a punched section for axial load calculation.
4. The allowable axial strength for distortional buckling is based on an assumed $k_y = 0$.
5. Weak axis and torsional bracing should have sufficient stiffness and strength to resist the axial load.
6. Allowable loads for built-up sections are based on maximum attachment interval of 24" o.c. via weld, bolts, or screws.
7. The StiffWall® Column must be used with the StiffWall Boot. Standard (S) will not fit inside the StiffWall Boot or Strap Track.
8. StiffWall Columns are delivered to the job site with Boots pre-attached at the top and bottom for fast installation.

Built-Up Section (Fastener Spacing = 24 in): Axial Compression Load (kips)													
Section (Built-up Column) (all 50 ksi)	Thickness (mils)	Max Unbraced Length = 48"				Max Unbraced Length = 60"				Max Unbraced Length = Full Height			
		SW Column Height (ft)				SW Column Height (ft)				SW Column Height (ft)			
		9	10	12	14	9	10	12	14	9	10	12	14
(3P) 350C/STW200-97	97 (C/STW), 97 (TP)	28.30	24.66	17.90	13.15	28.30	24.66	17.90	13.15	22.28	18.63	13.23	9.85
(3P) 350C/STW200-118	118 (C/STW), 97 (TP)	32.69	28.44	20.59	15.13	32.69	28.44	20.59	15.13	26.43	22.21	15.79	11.76
(3P) 362C/STW200-97	97 (C/STW), 97 (TP)	29.77	26.16	19.36	14.23	29.77	26.16	19.36	14.23	22.41	18.70	13.27	9.88
(3P) 362C/STW200-118	118 (C/STW), 97 (TP)	34.47	30.26	22.34	16.42	34.47	30.26	22.34	16.42	26.59	22.30	15.84	11.81
(4P) 362C/STW200-97	97 (C/STW), 97 (TP), 97 (T)	34.97	30.42	22.01	16.17	34.97	30.42	22.01	16.17	27.11	25.03	21.43	16.03
(4P) 362C/STW200-118	118 (C/STW), 97 (TP), 97 (T)	39.10	33.94	24.46	17.97	39.10	33.94	24.46	17.97	35.30	32.80	24.08	17.97
(3P) 400C/STW200-97	97 (C/STW), 97 (TP)	34.00	30.54	23.82	17.82	34.00	30.54	23.82	17.82	22.77	18.90	13.41	9.98
(3P) 400C/STW200-118	118 (C/STW), 97 (TP)	39.59	35.55	27.72	20.72	39.59	35.55	27.72	20.72	27.05	22.55	16.01	11.92
(4P) 400C/STW200-97	97 (C/STW), 97 (TP), 97 (T)	40.72	36.38	27.89	20.64	40.72	36.38	27.89	20.64	27.62	25.23	21.90	16.69
(4P) 400C/STW200-118	118 (C/STW), 97 (TP), 97 (T)	45.78	40.84	31.23	23.08	45.78	40.84	31.23	23.08	35.94	33.68	25.03	18.72
(3P) 550C/STW250-97	97 (C/STW), 97 (S)	56.31	53.63	47.88	41.88	54.17	53.63	47.88	41.88	35.83	32.11	25.39	18.87
(3P) 550C/STW250-118	118 (C/STW), 97 (S)	67.50	64.29	57.42	49.94	65.56	64.29	57.42	49.94	44.99	40.86	30.31	22.54
(3P) 600C/STW250-97	97 (C/STW), 97 (S)	58.51	56.13	50.98	45.51	54.89	54.89	50.98	45.51	36.24	32.39	25.43	19.00
(3P) 600C/STW250-118	118 (C/STW), 97 (S)	70.50	67.67	61.53	54.98	66.65	66.65	61.53	54.98	46.07	41.75	30.53	22.69
(4P) 600C/STW250-97	97 (C/STW), 97 (SGP)	82.23	79.29	72.57	65.37	74.96	79.29	72.57	65.37	69.98	65.46	56.08	46.68
(4P) 600C/STW250-118	118 (C/STW), 97 (SGP)	93.76	90.50	82.76	74.44	85.31	90.50	82.76	74.44	79.04	73.72	62.62	51.13
(5P) 600C/STW250-97	97 (C/STW), 97 (S), 97 (SGP)	95.30	91.40	82.98	74.03	95.30	91.40	82.98	74.03	78.91	73.13	61.30	49.73
(5P) 600C/STW250-118	118 (C/STW), 97 (S), 97 (SGP)	106.95	102.57	93.10	83.02	106.95	102.57	93.10	83.02	87.79	81.18	67.43	53.81
(3P) 800C/STW250-97	97 (C/STW), 97 (S)	63.53	63.53	63.53	60.04	60.10	60.10	60.10	60.04	39.27	34.69	26.52	20.36
(3P) 800C/STW250-118	118 (C/STW), 97 (S)	76.11	76.11	76.11	72.29	72.59	72.59	72.59	72.29	49.03	43.44	32.49	24.95
(4P) 800C/STW250-97	97 (C/STW), 97 (SGP)	92.13	92.13	92.13	87.36	83.63	83.63	83.63	87.36	79.69	74.74	64.44	54.09
(4P) 800C/STW250-118	118 (C/STW), 97 (SGP)	104.58	104.58	104.58	99.41	94.84	94.84	94.84	99.41	89.51	83.72	71.70	59.70
(5P) 800C/STW250-97	97 (C/STW), 97 (S), 97 (SGP)	107.85	107.85	107.49	100.93	97.96	97.96	107.49	100.93	89.91	83.62	70.70	57.98
(5P) 800C/STW250-118	118 (C/STW), 97 (S), 97 (SGP)	120.25	120.25	120.24	112.96	109.12	109.12	120.24	112.96	99.49	92.33	77.66	63.27

Boot Dimensions And Thickness

StiffWall® Boots are designed to provide the optimal cost-effective solution for shear wall connections. Six configurations are available to meet project requirements (Light, Plus, Small, Medium, Transition and Large). StiffWall Boots are sized to fit inside standard track and are available for 3.5", 3.625", 4", 5.5", 6" and 8" Depths. **During installation of StiffWall Boots, standard or plate washer shall be used with a size sufficient to cover the Boots' slots after installation.** Light and Plus Boots can be used with single StiffWall column only. The Steel Network will determine the actual bearing height the StiffWall Columns, which are delivered to the job site with Boots pre-attached at the top and bottom for fast installation.

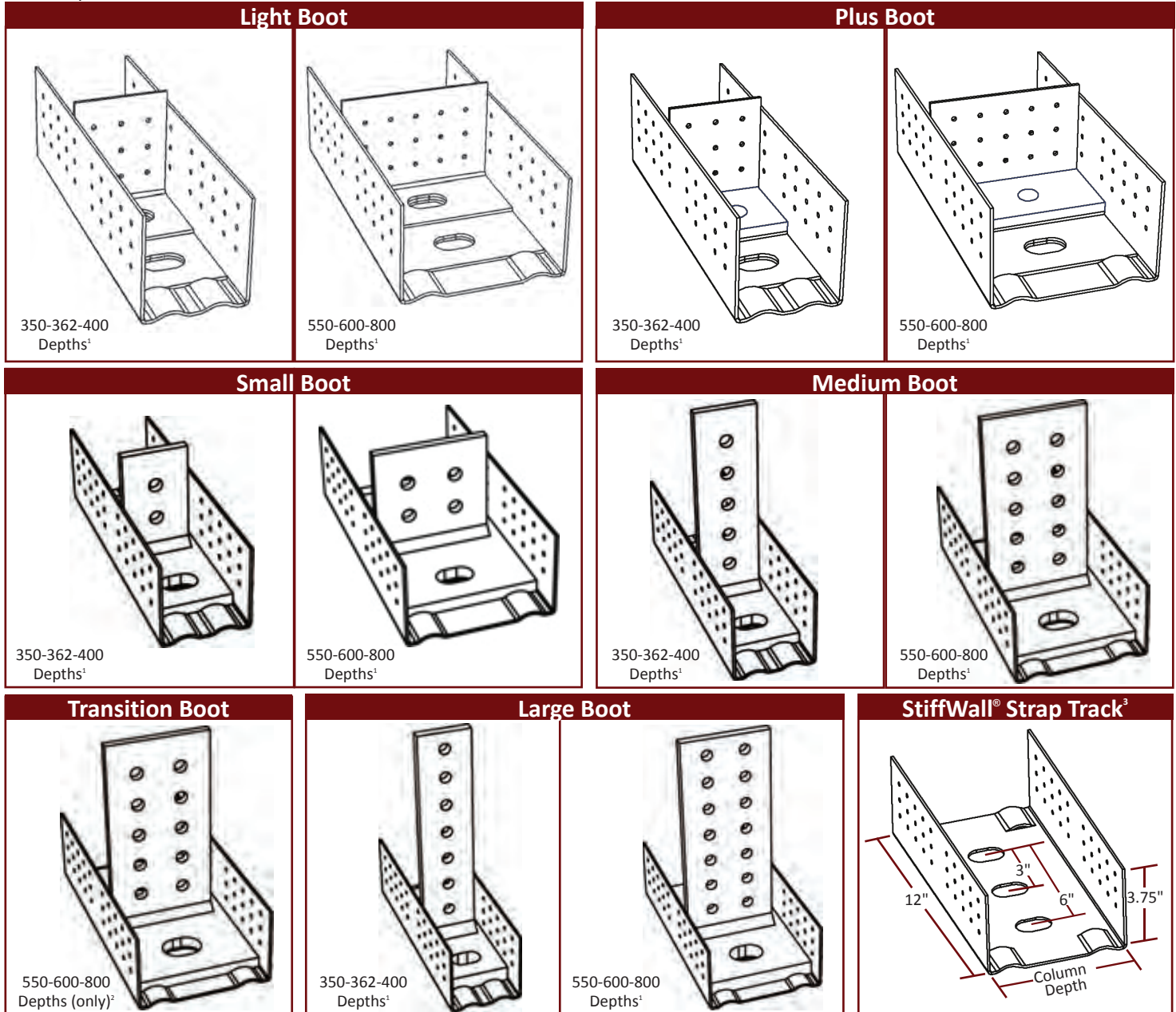

¹ Boots less than or equal to 4" and Light, Plus and Medium Boots greater than 4" contain guide holes for 7/8" anchors. Transition and Large Boots greater than 4" contain guide holes for 1 1/4" anchors.

² The StiffWall Transition Boot is used when the floor above uses a Small or Medium Boot and the floor below uses a Large Boot (for depths greater than 4" only). The anchor hole of the Transition Boot at the base of the wall couples with that of the Large Boot at the underside of the floor below to maintain the continuity of the through-floor fasteners (1 1/4" threaded rods or anchors).

³ StiffWall Strap Track is available in 12ga (97mils) thickness. Center hole is for conditions where only one anchor is necessary

Subtract Boot Thickness to Determine Column Bearing Height

The Steel Network will determine the actual bearing height of a StiffWall Column by subtracting the thickness of the StiffWall Boot and Strap Track elements on which it is bearing. For each boot, the Strap Track is 97mils thick. The dimensions of various boot elements are shown in the table below. Contact TSN for design recommendations or assistance with any light steel framing technical issue.

Boot Type	Strap Track Thickness	Base Plate Thickness	Additional Base Plate Thickness	Total Thickness of Two Boots ¹
Light, Plus	0.1017"	0	0.1242"	0.5"
Small, Medium, Transition	0.1017"	0.5"	0	1.25"
Large	0.1017"	0.75"	0	1.75"

¹ Total thickness rounded to nearest 1/32", with 1/32" added for installation tolerance.

Material Composition

Cold-Formed Steel: ASTM A 1003/A 1003M, ST50H or equivalent (Min. $F_y = 50$ ksi, Min. $F_u = 65$ ksi).

Structural Steel: ASTM A 572/A 572M, Grade 50 or equivalent (Min. $F_y = 50$ ksi, Min. $F_u = 65$ ksi).
Coating Powder – Black or TSN approved equivalent.

Bolts: ASTM F3125 Grade A325.

Important Notes

1. Allowable loads are based on analysis of loads and allowable stresses set by AISI S100 and AISC 360 Spec.
2. Straps tension T1 is the summation of tension forces in the the two diagonal straps.
3. Load paths for straps tension and column uplift are independent in the boot connection and allowable loads T1 and T2 can be combined for the same boot.
4. Check combined tension and shear in anchor bolts due to applied T1 and T2 values as per AISC 360 Specification, Sec. J3.7.
5. Check screw shear for T2 on Light and Plus boot connection to column. Factory-assembled kits come with 4 #12 screws by default. Up to 11 more screws can be added as specified by designer.
6. Allowable loads for wall aspect ratio other than listed can be interpolated, but not extrapolated.
7. Fillet Weld Designation is E70XX Metal Arc or equivalent. Thickness as specified.
8. Consider the provisions of AISI S400-15 in the design of connections when designing the lateral system in buildings assigned to Seismic Design Category (SDC) D, E, or F, or wherever the Seismic Response Modification Coefficient "R" used to determine the seismic design forces is greater than 3.

Load Direction Diagram

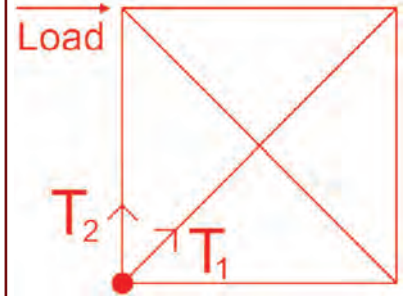

If load capacities exceed published loads, custom boot connections may be manufactured. Contact TSN for recommendations.

StiffWall® Boot Capacity (kips)

Wall		Light		Plus		Small / Medium / Transition		Large	
Width (in)	Aspect Ratio	Straps Tension	Column Uplift	Straps Tension	Column Uplift	Straps Tension	Column Uplift	Straps Tension	Column Uplift
	Vertical: Horizontal	T1	T2	T1	T2	T1	T2	T1	T2
3.5	0.6:1 (30.96 deg.)	12.00	1.78	12.75	4.79	18.60	8.65	18.60	19.46
	1:1 (45 deg.)	8.73	1.78	15.47	4.79	22.08	8.65	22.08	19.46
	2:1 (63.5 deg.)	6.91	1.78	12.38	4.79	26.81	8.65	29.01	19.46
3.625	0.6:1 (30.96 deg.)	11.59	1.83	12.75	4.98	18.60	8.98	18.60	20.21
	1:1 (45 deg.)	8.43	1.83	15.12	4.98	22.08	8.98	22.08	20.21
	2:1 (63.5 deg.)	6.67	1.83	11.95	4.98	25.88	8.98	29.01	20.21
4	0.6:1 (30.96 deg.)	10.50	1.97	12.75	5.56	18.60	9.98	18.60	22.46
	1:1 (45 deg.)	7.64	1.97	13.70	5.56	22.08	9.98	22.08	22.46
	2:1 (63.5 deg.)	6.04	1.97	10.83	5.56	23.46	9.98	29.01	22.46
5.5	0.6:1 (30.96 deg.)	7.64	2.49	12.75	7.86	18.60	13.98	21.48	35.76
	1:1 (45 deg.)	5.56	2.49	9.96	7.86	21.58	13.98	25.34	35.76
	2:1 (63.5 deg.)	4.39	2.49	7.88	7.86	17.06	13.98	32.23	35.76
6	0.6:1 (30.96 deg.)	7.00	2.65	12.55	8.62	18.60	15.32	21.48	39.16
	1:1 (45 deg.)	5.10	2.65	9.13	8.62	19.78	15.32	25.34	39.16
	2:1 (63.5 deg.)	4.03	2.65	7.22	8.62	15.64	15.32	32.23	39.16
8	0.6:1 (30.96 deg.)	5.25	3.21	9.41	11.69	18.60	20.65	21.48	52.80
	1:1 (45 deg.)	3.82	3.21	6.85	11.69	14.84	20.65	25.34	52.80
	2:1 (63.5 deg.)	3.02	3.21	5.42	11.69	11.73	20.65	25.81	52.80

Boot Components

StiffWall Boots come pre-assembled with StiffWall Columns. Please refer to the StiffWall product page for full system design and order information. Contact TSN technical support for design recommendations.

Please Note: Boot Kits may NOT be sold separately, as they are part of an engineered system.



StiffWall Base Plate



A325 Column Bolts

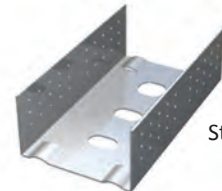

Strap Track

Sample Structure

The following example is used to illustrate the design capabilities of The Steel Network's StiffWall® SWS system as a shear panel to resist lateral loads. The information contained within this catalog shows the step by step design process used to design TSN's StiffWall.

Certain assumptions are made within the catalog and the example problem. All analyses are shown for example only and do not replace building code specific loading requirements and/or load combinations. Please contact The Steel Network for further information.

The example utilizes StiffWall in the construction of a 5-story building structure. Loads and reactions at each story have been provided as well as overall foundation reactions for anchorage design. Service wind loads and ASD design method are used. Two load cases were examined:

- (1) Dead + 0.6 In-plane Wind, (D + 0.6W)
- (2) Dead + 0.75 Live + 0.45 In-plane Wind, (D + 0.75L + 0.45W)

Important Design Considerations:

- D + W load combination is the controlling combination in this example. The wall depth is chosen as 6 inches.
- Uplift and tension loads in StiffWall columns are calculated with a tributary width from the dead load = 5 ft. (about 1/3 of panel width). Compression loads in StiffWall columns are calculated with a tributary width from dead load equal to stud spacing = 2 ft.
- End columns are designed as unbraced full height in the lateral and torsional directions under compression forces. Otherwise, if bracing is considered, it must be adequately designed for bracing force. See bridging data for details of lateral bracing calculations.
- Back-to-back end columns are designed to be attached together at 24 inch max. o.c.
- StiffWall does not substitute for floor rigidity. Sufficient diaphragm stiffness or an additional horizontal compression member is required to transfer the load.
- Floor summaries on the next page refer to the design steps previously given (pages titled StiffWall® SWS Design). Step 5 is designed by others.
- f'_c of foundation concrete = 4,000 psi.

Assumptions

- Stud Spacing = 24 inch o.c.
- Dead Load = 0.5 kips/ft.
- Live Load = 0.75 kips/ft.
- Tributary Width = 2.0 ft. for Compression check; 5 ft. for Uplift check
- D + 0.6W load combination checked
- D + 0.75L + 0.45W load combination checked

Uplift Check

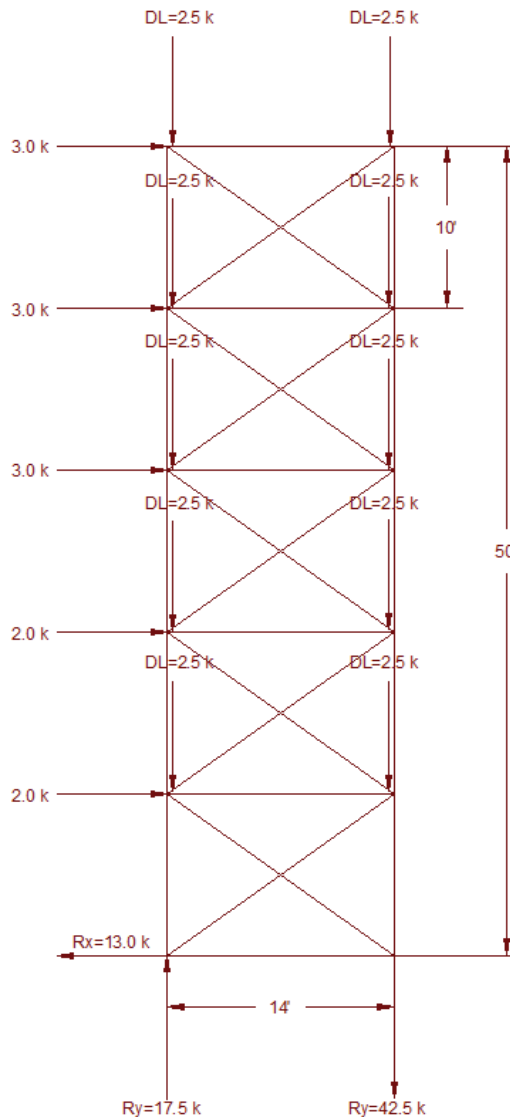

Maximum Compression Check

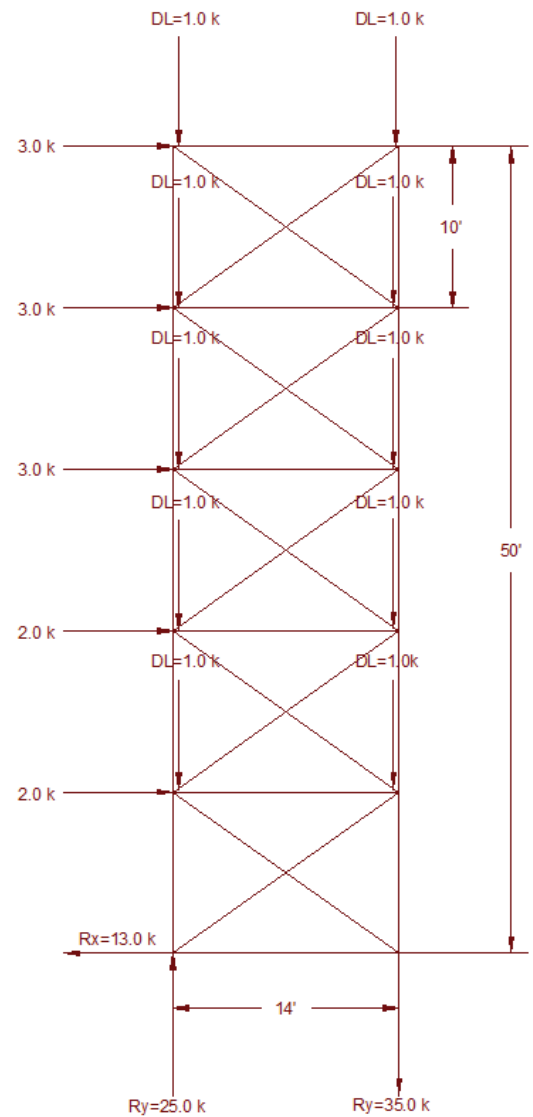

Uplift Check

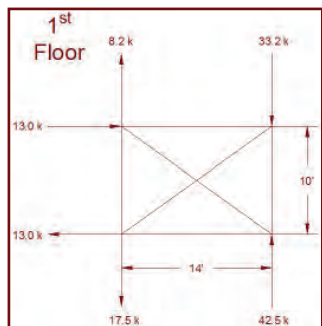
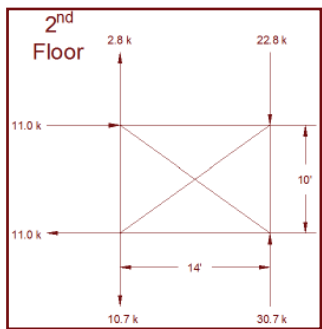
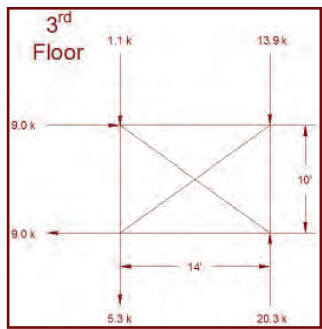
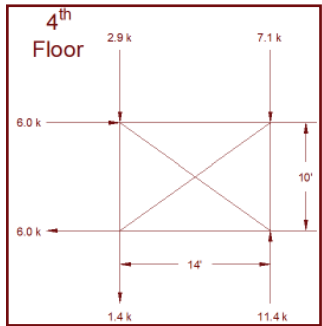
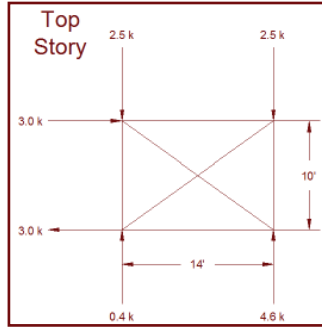

Loads on Top Floor Shear Wall From Analysis:

1. Column compression = 3.1 kips. No tension in column
 - Use 600C/STW250-54 with allowable capacity = 3.5 kips > 3.1 kips
2. Use StiffWall Light Boot with T1 capacity of 6.5
3. Attach StiffWall Light Boot to column using (4) #12 screws
4. The tension in the flat strap is: 3.7 kips in 2 straps:
 - Use (2) 4" x 54mil straps with capacity = 11.5 kips > 3.7 kips
 - Use (6) #12 screws each strap each Strap Track with capacity = 6.8 kips > 3.7 kips
5. No uplift in through-floor connection, shear = 3.0 kips
 - Use One 7/8" A325 bolt through floor

Loads on 4th Floor Shear Wall From Analysis:

1. Column compression = 8.4 kips. No tension in column
 - Use 600C/STW250-118 with allowable capacity = 10.7 kips > 8.4 kips
2. Use StiffWall® Plus Boot with T1 capacity = 11.6 kips
3. Attach StiffWall® Plus Boot to column using (4) #12 screws
4. The tension in the flat straps is: 7.4 kips in 2 straps:
 - Use (2) 4" x 54 mil straps with capacity = 11.5 kips > 7.4 kips
 - Use (7) #12 screws each strap to Strap Track with capacity = 8.0 kips > 7.4 kips
5. Uplift in through-floor connection = 1.4 kips, shear = 6.0 kips
 - Use One 7/8" A325 bolt through floor
 - Use (2) 7/8" A325 bolts at base to connect to Small Boot below

Loads on 3rd Floor Shear Wall From Analysis:

1. Column compression = 15.8 kips. No tension in column
 - Use (2) 600C/STW250-97 with allowable capacity = 25.5 kips > 15.8 kips
2. Use StiffWall Small Boot with T1 capacity = 18.9 kips
3. Attach StiffWall Small Boot to column using (4) 1/2" A325 bolts
4. The tension in the flat straps is: 11.1 kips in 2 straps:
 - Use (2) 4" x 54 mil straps with capacity = 11.5 kips > 11.1 kips
 - Use (10) #12 screws each strap to Strap Track with capacity = 11.4 kips > 11.1 kips
5. Uplift in through-floor connection = 5.3 kips, shear = 9.0 kips
 - Use (2) 7/8" A325 bolt through floor

Loads on 2nd Floor Shear Wall From Analysis:

1. Column compression = 24.7 kips.
 - Use (2) 600C/STW250-97 with allowable capacity = 25.5 kips > 24.7 kips
2. Column tension = 2.8 kips*
 - Use StiffWall Small Boot with T1 capacity = 18.9 kips & T2 capacity = 15.3 kips
3. Attach StiffWall Small Boot to column using (4) 1/2" A325 bolts
 - Capacity of (4) 1/2" A325 bolts to (2) 97 mil columns = 21.2 kips > 2.8 kips
4. The tension in the flat straps is: 13.5 kips in 2 straps:
 - Use (2) 6" x 54 mil straps with capacity = 17.3 kips > 13.5 kips
 - Use (12) #12 screws each strap to Strap Track with capacity = 13.7 kips > 13.5 kips
5. Uplift in through-floor connection = 10.7 kips, shear = 11.0 kips
 - Use (2) 7/8" A325 bolt through floor

* Uplift calculated using 5 ft. tributary width and dead load used to offset uplift at the tension side of the wall.

Loads on 1st Floor Shear Wall Loads From Analysis:

1. Column compression = 35.0 kips
 - Use (2) 600C/STW250-118 with allowable capacity = 34.7 kips ≈ 35.0 kips
2. Column tension = 8.2 kips*
 - Use StiffWall Small Boot with T1 capacity = 18.9 kips & T2 capacity = 15.3 kips
3. Attach StiffWall® Small Boot to column using (4) 1/2" A325 bolts
 - Capacity of (4) 1/2" A325 bolts to (2) 118 mil columns = 21.2 kips > 8.2 kips
4. The tension in the flat straps is: 16.0 kips in 2 straps:
 - Use (2) 6" x 54 mil straps with capacity = 17.3 kips > 16.0 kips
 - Use (15) #12 screws each strap to Strap Track with capacity = 17.1 kips > 16.0 kips
5. Anchorage uplift = 17.5 kips, shear = 13.0 kips
 - Use (2) 7/8" Hilti HIT-HY 200 Adhesive Anchors, HAS Super ASTM A193 B7, Embedment depth = 10.5 inches; check additional tension from prying action.

Max. Compression Check

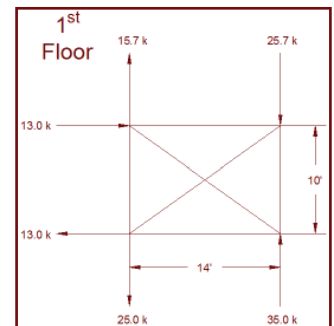
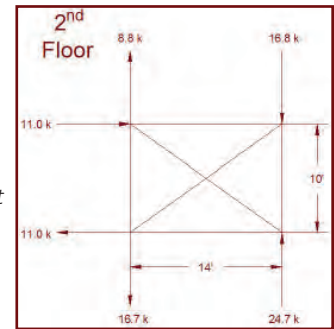
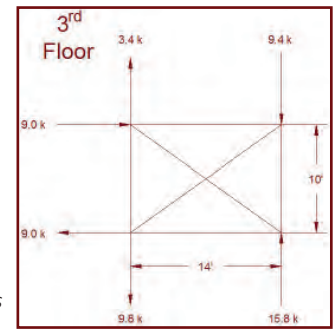
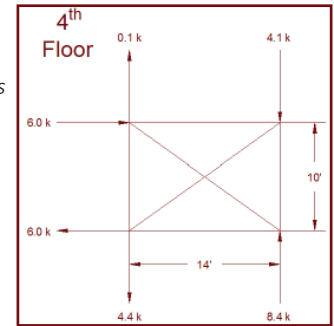
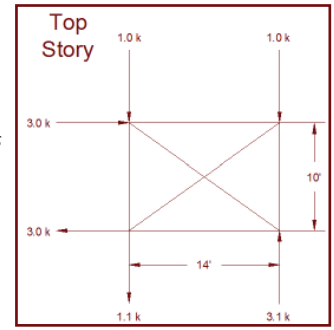

StiffWall® SWS Schedule					
Wall #	StiffWall® Column & Boot Section	Strap Bracing (50ksi)	Column Connection to Boot	Strap Track #12 Screws (Each Side)	Floor/Anchorage Connection
SW-5	600C/STW250-54-1-LT	(2) 4" x 54 mil	(4) #12 Screws	6	(1) 7/8" Bolt
SW-4	600C/STW250-118-1-PL	(2) 4" x 54 mil	(4) #12 Screws	7	(1) 7/8" Bolt, (2) at base
SW-3	600C/STW250-97-2-SM	(2) 4" x 54 mil	(4) 1/2" A325 Bolts	10	(2) 7/8" Bolt
SW-2	600C/STW250-97-2-SM	(2) 6" x 54 mil	(4) 1/2" A325 Bolts	12	(2) 7/8" Bolt
SW-1	600C/STW250-118-2-SM	(2) 6" x 54 mil	(4) 1/2" A325 Bolts	15	(2) 7/8" Hilti HIT-HY 200 Adhesive Anchors

Typical Detail, StiffWall® SWS Back-to-Back Column at SW-2 Above

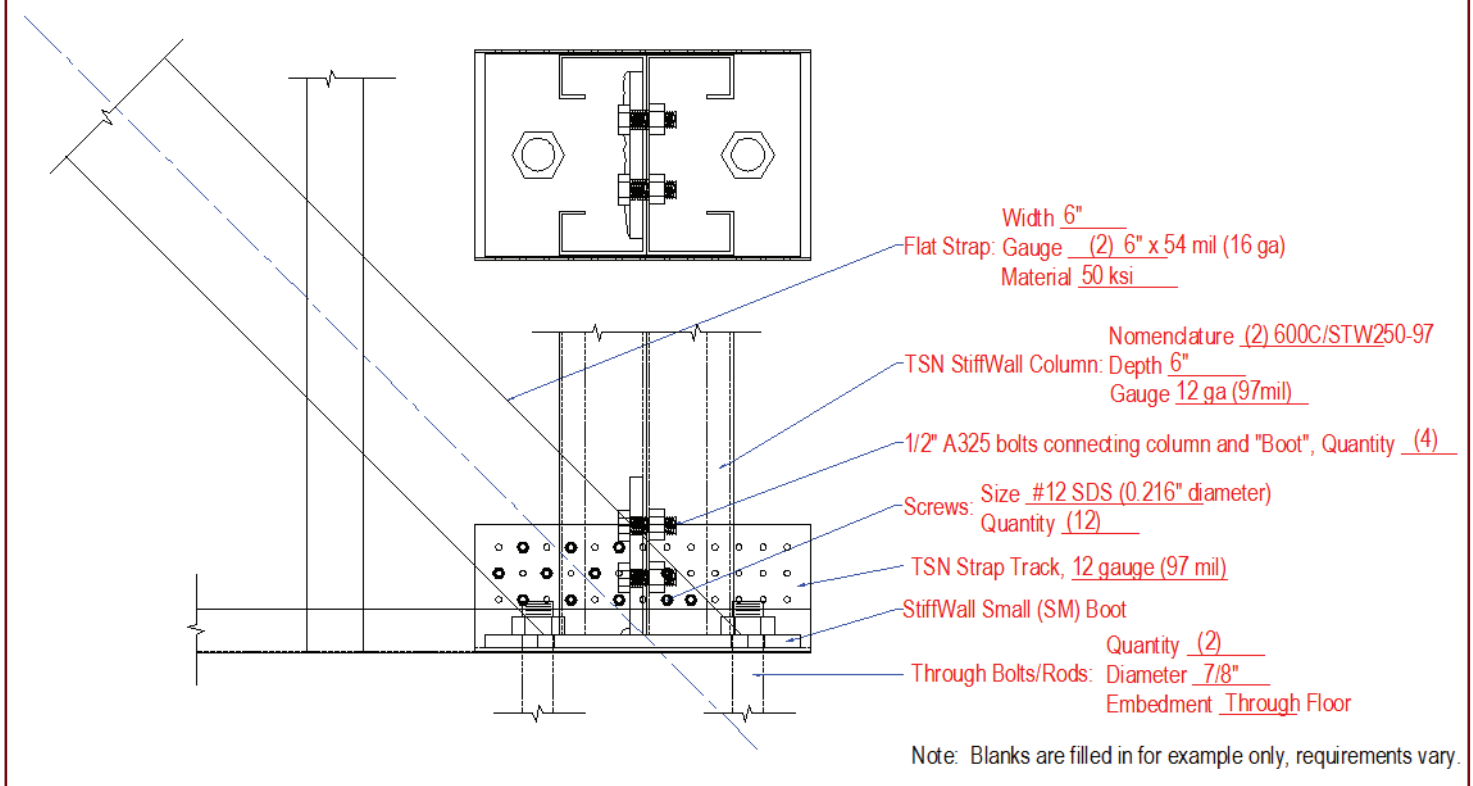



Material Properties

A1003 / A1003M ST50H [ST340H], Grade 50 (340), 50ksi (340MPa) minimum yield strength, 65ksi (450 MPa) minimum tensile strength, G-60 (Z180) hot-dipped galvanized coating; or equivalent.

Flat Strap Product Profile (For StiffWall®)						
Section	Width (D)	Gauge	Design Thickness (t)	Min. Steel Thickness (t _(min))	Area	Weight
	(in)		(in)	(in)	(in ²)	lbs/ft
FS400-54, 50 ksi	4	16	0.0566	0.0538	0.226	0.770
FS600-54, 50 ksi	6	16	0.0566	0.0538	0.340	1.156
FS800-54, 50 ksi	8	16	0.0566	0.0538	0.453	1.541
FS800-68, 50 ksi	8	14	0.0713	0.0677	0.570	1.941
FS1000-68, 50 ksi	10	14	0.0713	0.0677	0.713	2.426
Flat Strap Product Profile (For Bridging)						
FS200-43, 50 ksi	2	18	0.0451	0.0428	0.090	0.307
FS300-43, 50 ksi	3	18	0.0451	0.0428	0.135	0.460
FS300-54, 50 ksi	3	16	0.0566	0.0538	0.170	0.578

Table Notes:

- Section properties and capacities are calculated in accordance with AISI S100.
- Structural framing is produced to meet or exceed ASTM A653 and A1003.
- Non-Structural framing is produced to meet or exceed ASTM C645, A653, and A1003.
- Galvanized sheet steel meets or exceeds requirements of ASTM A924 & A1003.

Order Information for StiffWall Flat Strap

The Selection of flat strap for StiffWall® is simplified to 6 strap types, with load capacity factored using standard 12ga (97mil) strap track (see Step-By-Step Design Procedure on TSN's StiffWall product page for Allowable Flat Strap Capacity Chart). Flat Strap is cut to length with square ends, and will need to be cut to final length in the field. To determine the length of the flat straps, follow these simple steps:

1. Find the width (A) and the height (B) of the StiffWall.
2. Then, use the following formula to determine the length of the strap: $A^2 + B^2 = C^2$
3. Next, take the square root of C, round up to the nearest whole number and add 1

This will result in a length in feet that you can work with. If C equals a whole number, you may want to add 2 to make sure the length is enough.

Example: $8' \text{ wall height with a width of } 16' \text{ would look like this: } (8 \times 8) + (16 \times 16) = \sqrt{320} = 17.88$
Round up to 18' and add 1' for a strap length of 19'.

Some points to remember concerning Flat Strap:

- Strap must be pulled tight after a gravity load above has been applied. TightStrap® tool can be used to flatten the strap and put minor tension force into it.
- Flat strap cannot be installed, then un-installed by releasing the screws to the strap track, and then re-installed with screws again in the same screw holes. Either a new piece of strap is required, or the exposed edge of the strap needs to be welded to the strap track with an approved weld design.
- It is recommended not to fasten the strap to the infill studs between the columns. However, typical or occasional attachment of sheathing and/or resilient channel to the infill studs through the strap is acceptable.
- Straps should not be spliced without an approved design.
- Four (4) pieces of strap are required in each StiffWall (If there are 10 StiffWall shear walls, 40 pieces of flat strap will be necessary).

Shear Wall Systems

TightStrap® Strap Tensioner

Product Description

The pre-tensioning of a shear wall flat strap provides a means to ensure the shear wall will perform as designed. It is important that the flat straps are as tight as possible when installed to achieve optimal system performance.

TightStrap® is a unique device used to tension (tighten) flat strap in the field. Use TightStrap to improve structural performance of a shear wall by removing “waviness” or “bowing” prior to fastening.

TightStrap is designed to be used in both StiffWall® and generic flat strap shear walls. TightStrap’s track connector fastens to standard track at the corners of the shear wall to provide a base for the tensioning process. It is preferable to tighten the flat straps after applying some vertical load (own weight) on top of the shear wall panel.

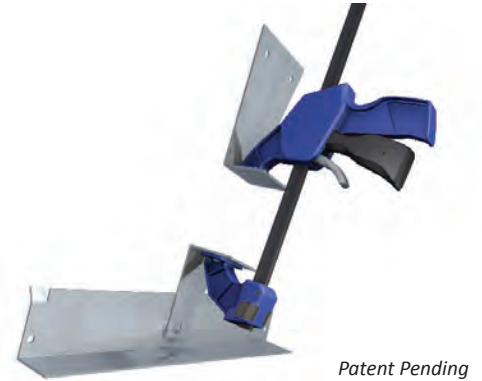

Patent Pending

Using TightStrap®

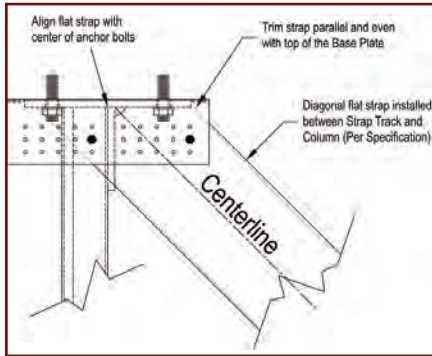

Step 1 - Align & trim flat strap at each corner, attach one end with at least 2 screws.

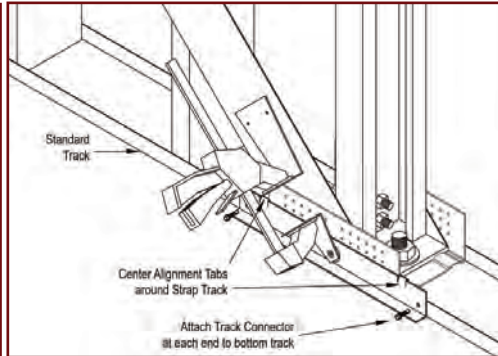

Step 2 - Align Track Connector and attach to track.

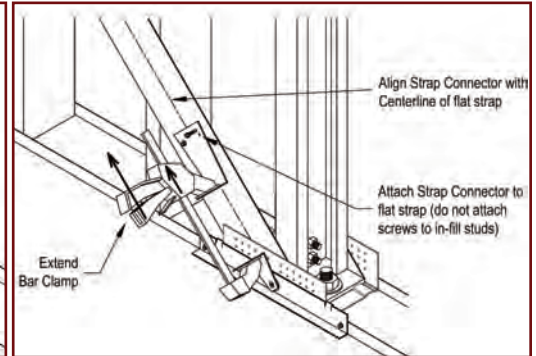

Step 3 - Extend Bar Clamp, align Strap Connector with centerline of flat strap and attach Strap Connector to the flat strap.

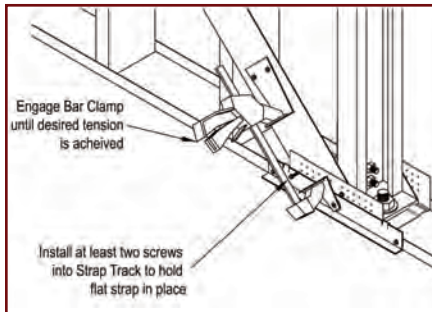

Step 4 - Engage Bar Clamp, install at least 2 screws for flat strap attachment, remove TightStrap and install remaining screws for strap attachment.

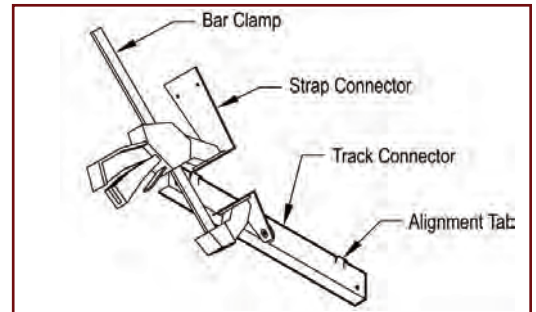

How to Install the StiffWall® Shear Wall:

The boots are attached to the foundation or floor and the roof or ceiling with approved anchors or bolts as determined and approved by the Engineer (Boots are made up of the Strap Track and the “T” shaped Base Plate)

- Light, Plus, Small & Medium Boots utilize a 7/8” anchor bolt or threaded rod.
- Transition and Large Boots utilize a 1/2” anchor bolt or threaded rod on boots less than or equal to 4”. Boots greater 4” contain guide holes for 1 1/4” anchor bolt or threaded rod.
- Attach the Flat Strap to the Strap Track, corner to corner, on both sides (4 straps needed) with the specified amount of #12 screws (or weld). The use of low profile screws help to reduce a “bump out” of finished sheetrock. To achieve the designed loads, the strap should be tight from corner to corner (with no slack). This is done by tightening the strap after the wall is loaded with a TightStrap® tool.

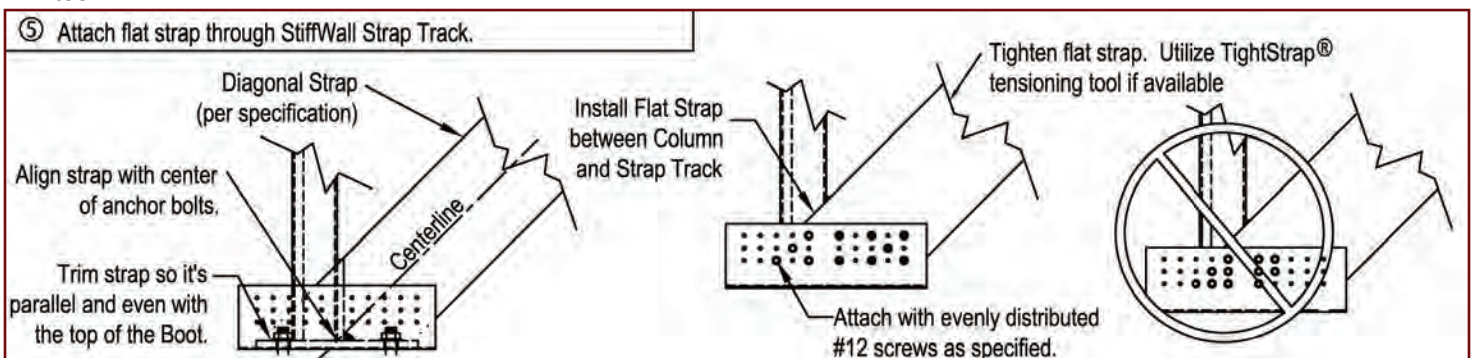

StiffWall® Placement in Load Bearing Wall

StiffWall is usually not designed as a gravity load bearing element. However, its boundary end columns can see compression loads from the floor weight above. This system is designed to sit in between load bearing studs and address all of the lateral loads acting on that building due to wind or earthquakes.

The StiffWall is designed to stack vertically and attach through the floor system to the level above (Fig. 1). The Columns for one floor must line up with the columns on the floors above and below. This will allow for the bolts from one floor to be bolted through the floor system to the boots above and/or below. It is important that these bolts are properly aligned through each floor for the walls to be able to work together as one unit from top to bottom. Do not enlarge the anchor holes in the StiffWall Boots.

It is recommended that StiffWall boundary end columns have axial compression capacity greater than or equal to the typical load bearing stud within the wall.

Attachment of Sheathing to the StiffWall® Column

Since the StiffWall assembly is installed within the thickness of the top and bottom tracks, sheathing should not be attached directly to the StiffWall Column. The thickness of the strap track on either side of the wall (97mils [12ga]) reduces the depth of the StiffWall Column within the assembly (Fig. 2). As a result, if the sheathing is attached to the StiffWall Column, a level plane will not occur along the wall. Attach the sheathing to the infill studs bordering the StiffWall columns.

Vertically Stacking Shear Walls

StiffWall shear walls transfer loads concentrically from the floor element above to the floor element below. The StiffWall system should consist of vertically stacked panels to effectively transfer lateral forces to the foundation (Fig. 3). Any eccentricity in the system negatively affects the load distribution to the StiffWall components. The vertical alignment of the walls is critical for the through-floor connections. Coordinate installation to ensure through-floor connectors align with StiffWall Boots on the floors above and below.

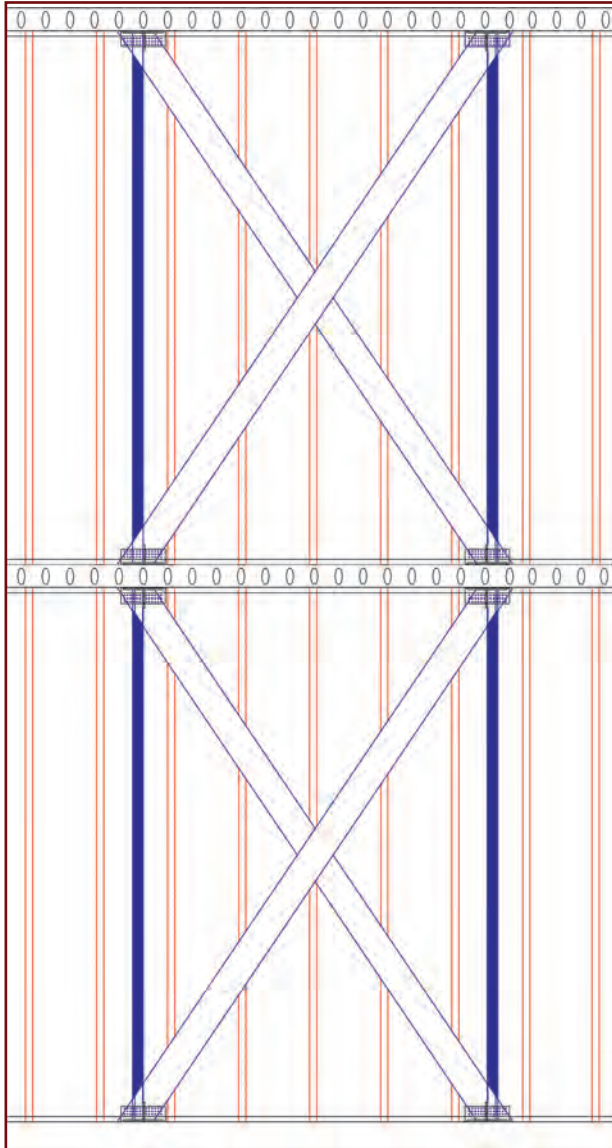

Fig. 1: StiffWall Column/Boot Assembly (blue line) is placed within the spacing of the SigmaStud® (in red).

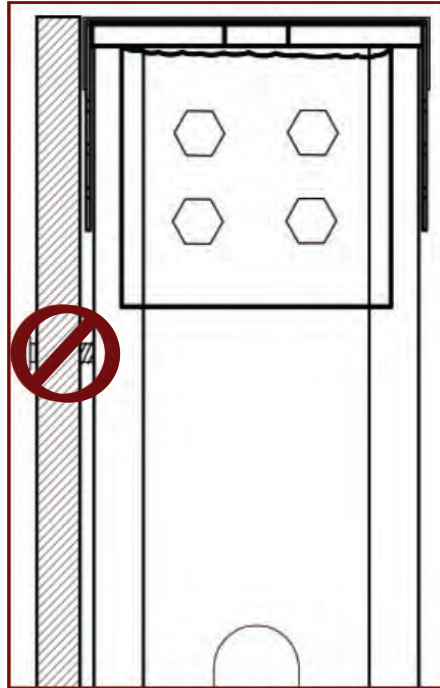

Fig. 2: Sheathing should not be attached directly to the StiffWall Column. Attach the sheathing to the adjacent studs.

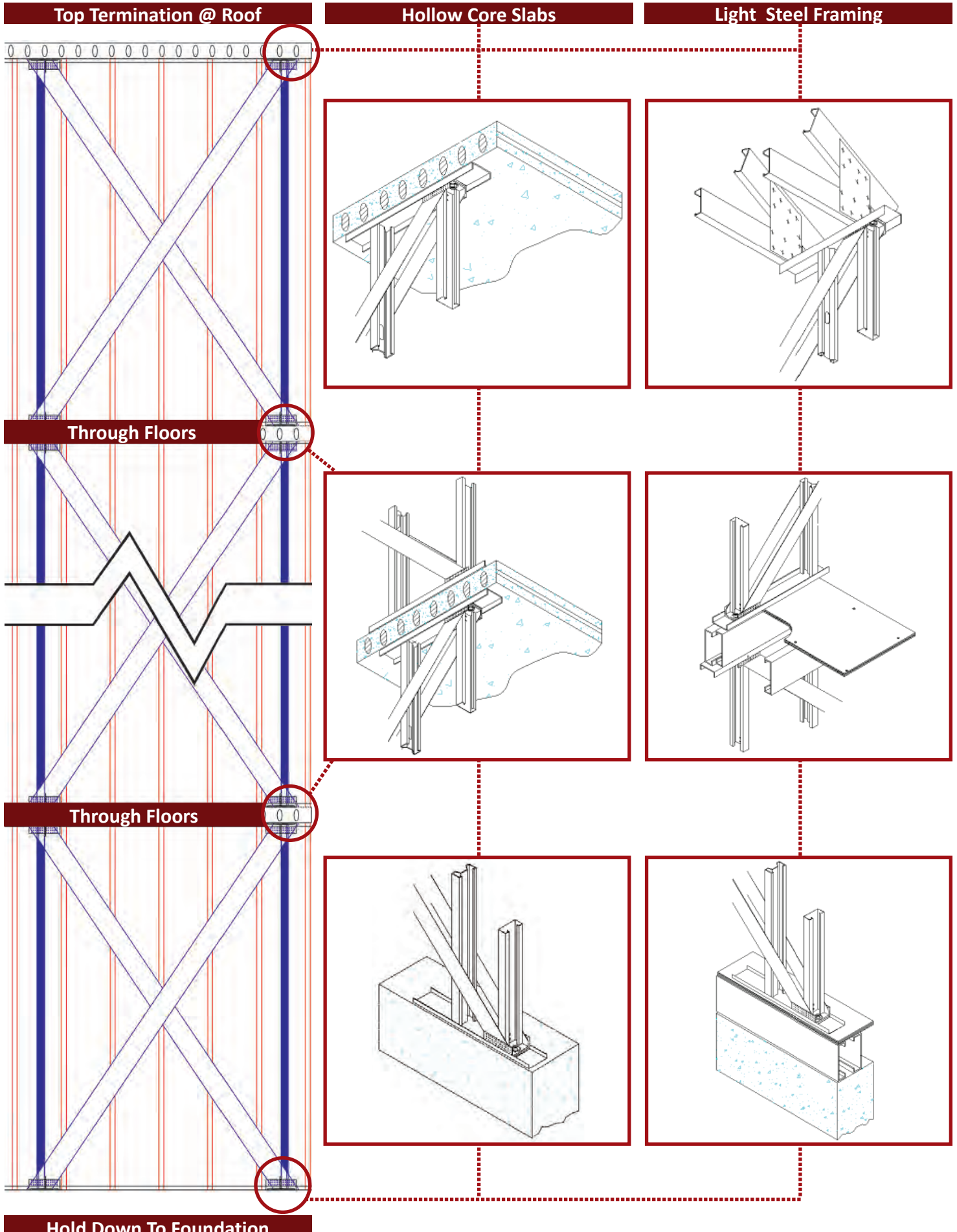

Fig. 3: Shear walls should be stacked vertically.



Shear Wall Systems

Example Details



Floor Systems Appropriate for Cold-Formed Steel Load Bearing Construction

Several types of floor systems can be integrated with cold-formed steel stud load bearing walls. Among these floor systems are the composite steel deck-concrete slab, composite bar joist with concrete on metal deck or structural panel floor diaphragm, hollow core concrete planks or cold-formed steel joist with concrete on metal deck or structural panel floor diaphragm. This section provides a short introduction to these floor systems.

Composite steel deck-concrete slabs combine the structural advantage of a flat slab with the time saving advantage of a permanent form. The steel deck furnishes the total bottom reinforcement of the composite slab, while additional top reinforcement is required. Due to the composite action between the concrete and the steel deck, the slab can support a greater floor live load than a typical reinforced concrete slab of the same depth. The steel deck is typically spot-welded to the top track of the wall panel.

Composite bar joist with concrete on metal deck or structural panel floor diaphragm enables clear spans for 10 to 24 inch deep system. The metal deck provides permanent form and tension reinforcement, and the concrete slab thickness is typically about 2½" on top of deck. This system necessitates in-line framing between the joists and the wall studs to ensure transfer of gravity loads to the wall studs without eccentricity.

Precast hollow core concrete slabs provide the advantages of rapid field installation. The planks are typically produced in 6, 8, 10, 12, and 16 inch depths. The hollow core floor system provides long design spans compared to other systems meeting the requirements of cold-formed steel load bearing construction. However, factors such as concentrated loads and large openings can affect the span capabilities of the system. Sound Transmission Class (STC) rating and fire resistance rating typically meet the most stringent design criteria.

Cold-formed steel joist with concrete on metal deck or structural panel floor diaphragm is a non-composite system that is significantly lighter than all other floor systems. The joists are typically 8 to 16 inches deep. Relatively sizeable cold-formed steel joists (97 mils thick and 14 inches deep) can accommodate clear spans up to 30 ft. Cold-formed steel joists require lateral bracing, or blocking, to prevent lateral torsional buckling, and may require end and intermediate bearing stiffeners to prevent web crippling.



Composite Steel Deck



Pre-Cast Hollow Core Slab



Composite Bar Joist



Cold-Formed Steel Joist

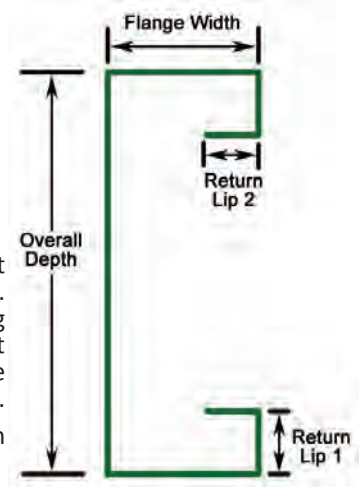

Background

PrimeJoist is a revolutionary addition to the light gauge steel stud industry, producing significant economies in both design and installation when compared with conventional “C” Shaped studs. PrimeJoist’s unique configuration delivers increased strength and stiffness, minimizing or eliminating the use of built-up joist sections in floor assemblies. Available in all common floor joist depths, PrimeJoist streamlines the design and construction process. PrimeJoist’s shape is easily differentiated from the typical c-shape, enabling the selection of the most optimal member sizes to fit project conditions.

ASI’s SteelSmart® System software includes the complete database of sections to quickly design PrimeJoist floor joists and connections. Visit www.steelSMARTsystem.com for your copy today!



Benefits That Add Value:

Quality

- Increases load capacity over a standard “C-shaped” stud of the same thickness, reducing overall materials needed
- Increased stiffness for deflection
- Increased load capacity enables selection of optimal thickness of flooring members

Value

- Simplified joist and floor system design
- Lighter weight results in shipping efficiencies and easier handling
- Provides a flat surface for attachment of door or window frame, requiring no additional track
- No welding or fastening built-up members together



Introduction

Fire-resistance ratings have long been used by UL and the building codes to measure the performance of building components or assemblies in a fire situation. Fire-resistance rating of a floor system classifies the ability of the floor assembly to confine and isolate fire within a zone comprised of the assembly. The ratings are obtained from fire tests designed to determine the time it takes for a fire to raise the temperature to unacceptable levels. Building codes require fire resistance ratings that are based on laboratory testing done in accordance with ASTM E119: Standard Test Methods for Fire Tests of Building Construction and Materials.

Sound Transmission Class (STC) of a floor system measures the ability of the floor assembly to block airborne sound transmission. STC is reported as a numerical value, and higher values represent a better ability to block airborne sounds. STC can be measured through a laboratory test which is based on ASTM E90, or a field test that is based on ASTM E413.

Impact Insulation Class (IIC) of a floor system measures the ability of the floor assembly to block impact sound transmitted through the assembly and structure. Impact sound transmission arises from a variety of sources, most notably the movement of people within a building. Like STC values, IIC also is reported as a numerical value, and higher values represent less sound transmission. The procedure for the IIC test is defined in ASTM E492 and E989.

Fire-resistance rated floor assemblies are identified in the UL Fire Resistance Directory, and can be found at the Underwriters Laboratories website at ul.com. Data for STC and IIC can be found for some assemblies through specific publications such as "A Guide to Fire and Acoustic Data for Cold-Formed Steel Floor, Wall & Roof Assemblies" by the Steel Framing Alliance. This section presents sample rated floor assemblies from this publication.

UL G549 Fire Resistance Rating: 1hr

- 1 3/8" concrete
- 28 ga (0.015" thick) steel deck with 5/8" deep corrugations
- 8" x 18 MSG steel joist spaced at 16" o.c. or 24" o.c.
- Optional resilient metal channels spaced at 24" o.c.
- Optional 3 1/2" mineral wool or glass fiber batt insulation
- 2 layers of 1/2" gypsum board on ceiling side

Sound Transmission Class	Impact Insulation Class
24" Joist Spacing	
65* (GFB RC) 60* (NI RC)	29* (GFB RC) 30* (NI RC)
16" Joist Spacing	
66* (GFB RC) 60* (NI RC)	34* (GFB RC) <30* (NI RC)

* Estimated value per Warnock (2008)

^a TLF-02-051a

^b IIF-02-032

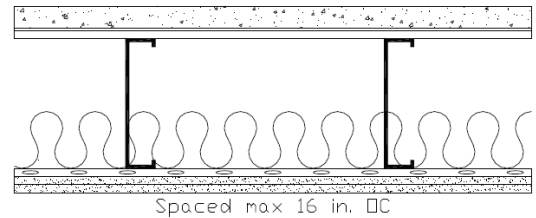
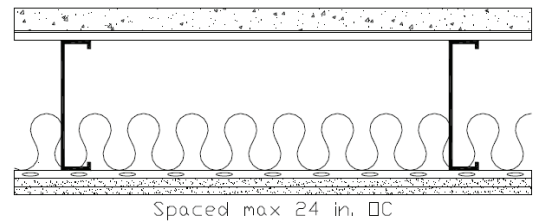

UL G557 Fire Resistance Rating: 2hr

- Subfloor of 3/4" thick tongue-and-groove cement-fiber board designated "Fortacrete"
- 10" x 16 MSG, 6" x 18 MSG or 8" x 16 MSG steel joist spaced at 24" o.c.
- 3 3/8" glass fiber batt insulation
- Resilient metal channels spaced at 12" o.c.
- 2 layers of 5/8" gypsum board on ceiling side.

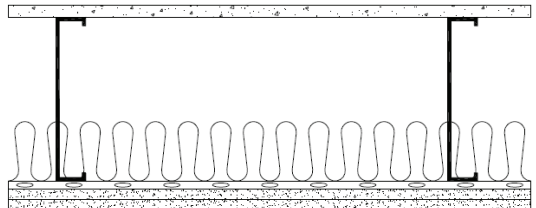

UL G565 Fire Resistance Rating: 1 hr, 1 1/2 hr, 2 hr

- 1" min. floor topping mixture with 3,500 psi comp. strength
- 3/16" min. deep, 22 MSG corrugated fluted steel deck
- 9 1/4" x 16 MSG steel joist spaced at 24" o.c.
- 3 1/2" mineral wool or glass fiber insulation
- 1 and 1/2 hour – 1 layer of 5/8" gypsum board on ceiling side
- 2 hour – 2 layers of 5/8" gypsum board on ceiling side

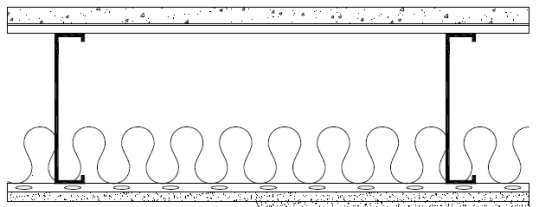

UL L568 Fire Resistance Rating: 45 min

- Subfloor of 5/8" plywood and finish floor of 5/8" wood structural panels
- 8" x 18 MSG steel joists spaced at 16" o.c.
- Resilient metal channels spaced 16" o.c.
- 3 1/2" mineral wool batt insulation
- 1 layer of 5/8" gypsum board on ceiling side

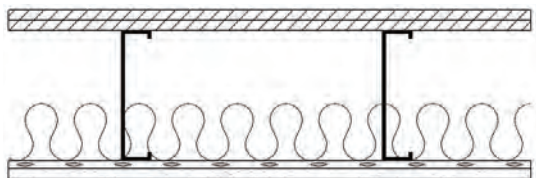

Sound Transmission Class	Impact Insulation Class
53*	46*

* Estimated value per Warnock (2008)

Floor Systems

Design Considerations

Introduction

PrimeJoist® is a structural element within the floor assembly where the assembly consists of the PrimeJoist section, metal deck or sheathing attached to the top compression flange, and discrete or continuous bracing attached to the tension flange. As a result, the behavior of the PrimeJoist section is restrained within the floor assembly. The design of PrimeJoist should be in accordance with AISI S100, North American Specification for the Design of Cold-Formed Steel Structural Members, and AISI S240-15, North American Standard for Cold-Formed Steel Structural Framing. Based on the provisions of these two code-referenced documents, the PrimeJoist section would then be checked for the following potential strength and serviceability limit states:

- Initiation of yielding for major axis bending
- Distortional buckling
- Shear
- Web crippling
- Combinations of bending and shear and bending and web crippling
- Vertical deflection at mid-span
- Vertical vibration

Floor Joist Bracing:

Section B1.2.1 in AISI S240-15 Standard permits joist design on the basis of either discretely braced design or continuously braced design. Assumptions for the two methods of design are as follows:

- In discretely braced design, the joist shall be designed neglecting the structural bracing and/or composite action contribution of attached sheathing or deck. Discretely braced design includes assemblies where the sheathing or deck is not attached directly to the joist.
- In continuously braced design, AISI S240-15 Standard limits joist maximum depth to 14 inches, joist maximum thickness to 118 mil (12 ga) and joist maximum design yield strength to 50 ksi. It also requires that the engineering drawings shall identify the sheathing or deck as a structural element. Section B4.5 of AISI S240-15 states that the sheathing shall consist of a minimum of 3/8 inch wood structural sheathing that complies with DOC PS 1, DOC PS 2, CSA 0437 or CSA 0325, or steel deck with a minimum profile depth of 9/16 inch and a minimum thickness of 27 mil. The sheathing or deck shall be attached with minimum No. 8 screws at a maximum 12 inches on center. In addition, it is required that for joist spans that exceed 8 feet, the tension flange shall be laterally braced at a maximum spacing of 8 feet.

Web Crippling:

Web crippling strength is the resistance of a cold-formed steel section with a large web slenderness ratio to resist crippling due to high local intensity of the load or reaction. Section B2.2.3 in AISI S240-15 Standard states that web crippling of floor joists shall be evaluated by using Section C3.4 of AISI S100-12 Spec, or Section G5 or Section G6 of AISI S100-16 Spec, unless a bearing stiffener is used. The design of bearing stiffeners, other than clip angle bearing stiffeners, shall be in accordance with Section C3.7.1 or Section C3.7.2 of AISI S100-12 Spec, or Section G5 or G6 of AISI S100-16 Spec. Clip angle bearing stiffeners shall be designed in accordance with Section B2.5.1 of AISI S240-15 Standard.

Vertical Deflection and Vibration:

The limitations on maximum vertical deflection and maximum vibration of cold-formed steel floor joists are typically specified in a project with the serviceability limits of the floor system. Vertical deflection limits are available in buildings codes as part of the general design requirements. A limit of L/360 for live load and L/240 for total dead and live load are typically used. However since building codes don't provide limits for floor vibration, it is recommended to use a limit of L/480 for live load to gain additional floor rigidity against any possible floor vibration.

Web Cutouts:

Web cutouts of cold-formed steel floor joists are sometimes required to run duct work or pipes through the floor system. A methodology for a reinforcement solution for the cutout can be engineered by the design professional of the project to restore the design bending capacity of the joist. One reinforcement methodology is to use cold-formed steel channel sections as web reinforcement above and below the cutout. Another methodology is to use a cold-formed steel track section back-to-back with the joist as web reinforcement. In either case, the web reinforcement piece(s) should be attached to the joist by either self-drilling screws or by weld. Some general recommendations about web cutouts are:

- Limit cutout size to a maximum of ½ the depth of the joist.
- Locate the cutout in the center 40% of the joist span, away from high shear zones. Cutouts closer to supports are not recommended, but could be designed if size is limited.



Floor Systems

PrimeJoist® Product Profile

Important Notes

1. Calculated properties are based on AISI S100-16, "North American Specification for the Design of Cold-Formed Steel Structural Members."
2. Effective properties incorporate the strength increase from the cold-work of forming as applicable per AISI S100-16 Spec, Sec. A3.3.2 (3).
3. Tabulated gross properties are based on the full-unreduced cross section of the studs, away from punchouts.
4. Allowable moment is the lesser of M_{ai} and M_{ad} . Stud distortional buckling is based on an assumed $k_{\phi} = 0$.
5. For deflection calculations, use the effective moment of inertia.
6. The effective moment of inertia for deflection is calculated at a stress which results in a section modulus such that the stress times the section modulus at that stress is equal to the allowable moment. AISI S100-16 Specification Procedure I for serviceability determination has been used. Increases in the effective moment of Inertia (I_{xe}) may be possible at lower stress levels. Any modified values would be required to be calculated by a qualified engineer.

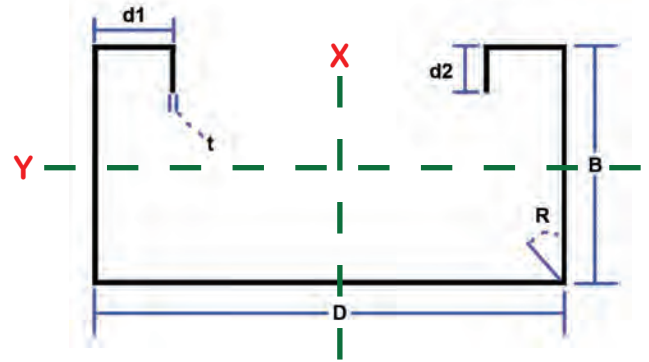

PrimeJoist® Section Dimensions							
Section (All Studs 50ksi)	Overall Depth	Flange Width	Return Lip 1	Return Lip 2	Inside Bend Radius	Design Thickness	Unit Weight
	D (in)	B (in)	d1 (in)	d2 (in)	R (in)	t (in)	(lbs/ft)
600PJ250-43	6	2.5	0.610	0.5	0.105	0.0451	1.94
600PJ250-54	6	2.5	0.633	0.5	0.105	0.0566	2.42
600PJ250-68	6	2.5	0.663	0.5	0.105	0.0713	3.04
600PJ250-97	6	2.5	0.723	0.5	0.105	0.1017	4.30
600PJ250-118	6	2.5	0.768	0.5	0.105	0.1242	5.22
600PJ350-68	6	3.5	0.663	0.5	0.105	0.0713	3.53
600PJ350-97	6	3.5	0.723	0.5	0.105	0.1017	5.00
600PJ350-118	6	3.5	0.768	0.5	0.105	0.1242	6.06
800PJ250-43	8	2.5	0.610	0.5	0.105	0.0451	2.24
800PJ250-54	8	2.5	0.633	0.5	0.105	0.0566	2.81
800PJ250-68	8	2.5	0.663	0.5	0.105	0.0713	3.53
800PJ250-97	8	2.5	0.723	0.5	0.105	0.1017	5.00
800PJ250-118	8	2.5	0.768	0.5	0.105	0.1242	6.06
800PJ350-68	8	3.5	0.663	0.5	0.105	0.0713	4.01
800PJ350-97	8	3.5	0.723	0.5	0.105	0.1017	5.69
800PJ350-118	8	3.5	0.768	0.5	0.105	0.1242	6.90
1000PJ250-43	10	2.5	0.610	0.5	0.105	0.0451	2.55
1000PJ250-54	10	2.5	0.633	0.5	0.105	0.0566	3.19
1000PJ250-68	10	2.5	0.663	0.5	0.105	0.0713	4.01
1000PJ250-97	10	2.5	0.723	0.5	0.105	0.1017	5.69
1000PJ250-118	10	2.5	0.768	0.5	0.105	0.1242	6.90
1000PJ350-68	10	3.5	0.663	0.5	0.105	0.0713	4.50
1000PJ350-97	10	3.5	0.723	0.5	0.105	0.1017	6.38
1000PJ350-118	10	3.5	0.768	0.5	0.105	0.1242	7.75
1200PJ250-54	12	2.5	0.633	0.5	0.105	0.0566	3.58
1200PJ250-68	12	2.5	0.663	0.5	0.105	0.0713	4.50
1200PJ250-97	12	2.5	0.723	0.5	0.105	0.1017	6.38
1200PJ250-118	12	2.5	0.768	0.5	0.105	0.1242	7.75
1200PJ350-68	12	3.5	0.663	0.5	0.105	0.0713	4.98
1200PJ350-97	12	3.5	0.723	0.5	0.105	0.1017	7.07
1200PJ350-118	12	3.5	0.768	0.5	0.105	0.1242	8.59
1400PJ250-54	14	2.5	0.633	0.5	0.105	0.0566	3.96
1400PJ250-68	14	2.5	0.663	0.5	0.105	0.0713	4.98
1400PJ250-97	14	2.5	0.723	0.5	0.105	0.1017	7.07
1400PJ250-118	14	2.5	0.768	0.5	0.105	0.1242	8.59
1400PJ350-68	14	3.5	0.663	0.5	0.105	0.0713	5.47
1400PJ350-97	14	3.5	0.723	0.5	0.105	0.1017	7.76
1400PJ350-118	14	3.5	0.768	0.5	0.105	0.1242	9.44
1600PJ250-68	16	2.5	0.663	0.5	0.105	0.0713	5.47
1600PJ250-97	16	2.5	0.723	0.5	0.105	0.1017	7.76
1600PJ250-118	16	2.5	0.768	0.5	0.105	0.1242	9.44

Material Properties

ASTM A1003/A1003M or ASTM A653/A653M, Grade 50 (340), 50ksi (340MPa) minimum yield strength, 65ksi (450 MPa) minimum tensile strength, G-60 (Z180) hot-dipped galvanized coating.

Important Notes

1. Calculated properties are based on AISI S100-16 Spec, "North American Specification for the Design of Cold-Formed Steel Structural Members."
2. Effective properties incorporate the strength increase from the cold-work of forming as applicable per AISI S100-16 Spec, Sec. A3.3.2 (3).
3. Tabulated gross properties are based on the full-unreduced cross section of the studs, away from punchouts.
4. Allowable moment is the lesser of M_{al} and M_{ad} . Stud distortional buckling is based on an assumed $k_{\phi} = 0$.
5. For deflection calculations, use the effective moment of inertia.
6. The effective moment of inertia for deflection is calculated at a stress which results in a section modulus such that the stress times the section modulus at that stress is equal to the allowable moment. AISI S100-16 Specification Procedure I for serviceability determination has been used. Increases in the effective moment of Inertia (I_{xe}) may be possible at lower stress levels. Any modified values would be required to be calculated by a qualified engineer.

Section (All 50 ksi)	Gross Properties						Effective Properties						Torsional Properties						L_u (in)	
	Area	I_x	S_x	R_x	I_y	R_y	I_{xe}	S_{xe}	M_{al}	M_{ad}	$M_{ad(net)}$	V_a	$V_{a(net)}$	$Jx10^9$	C_w	X_o	m	R_o		β
	(in ²)	(in ⁴)	(in ³)	(in)	(in ⁴)	(in)	(in ⁴)	(in ³)	(in-k)	(in-k)	(in-k)	(lbs)	(lbs)	(in ⁴)	(in ⁶)	(in)	(in)	(in)		
600PJ250-43	0.569	3.261	1.087	2.394	0.519	0.955	3.245	0.919	27.502	23.662	23.076	1,432	1,235	0.386	4.150	-2.088	1.266	3.317	0.604	53.32
600PJ250-54	0.712	4.058	1.353	2.387	0.644	0.951	4.058	1.174	35.140	32.383	31.545	2,842	1,942	0.760	5.163	-2.082	1.263	3.307	0.604	53.38
600PJ250-68	0.894	5.055	1.685	2.378	0.801	0.947	5.055	1.526	45.679	44.254	43.085	5,352	2,882	1.514	6.431	-2.074	1.259	3.295	0.604	53.47
600PJ250-97	1.265	7.047	2.349	2.361	1.111	0.937	7.047	2.305	77.070	76.026	73.996	10,653	3,964	4.360	8.956	-2.058	1.250	3.269	0.604	53.76
600PJ250-118	1.533	8.447	2.816	2.348	1.327	0.930	8.447	2.816	95.909	95.909	95.417	12,905	3,888	7.855	10.726	-2.045	1.244	3.250	0.604	54.06
600PJ350-68	1.036	6.309	2.103	2.467	1.799	1.318	6.055	1.628	48.757	47.851	46.671	5,352	2,882	1.756	14.285	-3.006	1.771	4.106	0.464	71.51
600PJ350-97	1.468	8.816	2.939	2.451	2.513	1.308	8.730	2.534	75.856	77.711	75.750	10,653	3,964	5.061	20.020	-2.990	1.763	4.081	0.463	72.01
600PJ350-118	1.781	10.588	3.529	2.438	3.017	1.302	10.588	3.341	100.023	100.888	98.416	12,905	3,888	9.127	24.090	-2.978	1.757	4.063	0.463	72.48
800PJ250-43	0.659	6.378	1.595	3.110	0.572	0.931	6.378	1.225	36.664	32.254	31.517	1,060	1,060	0.447	7.513	-1.869	1.159	3.746	0.751	52.27
800PJ250-54	0.825	7.949	1.987	3.103	0.710	0.927	7.949	1.700	50.893	44.463	43.391	2,102	2,102	0.881	9.340	-1.862	1.156	3.736	0.752	52.24
800PJ250-68	1.036	9.923	2.481	3.095	0.883	0.923	9.923	2.260	67.676	61.309	59.780	4,218	3,367	1.756	11.624	-1.854	1.151	3.724	0.752	52.23
800PJ250-97	1.468	13.893	3.473	3.076	1.225	0.914	13.893	3.409	113.945	106.907	104.140	10,888	6,034	5.061	16.161	-1.838	1.142	3.698	0.753	52.24
800PJ250-118	1.781	16.707	4.177	3.063	1.464	0.907	16.707	4.177	142.266	140.446	136.945	16,239	7,314	9.127	19.330	-1.825	1.136	3.679	0.754	52.30
800PJ350-68	1.179	12.165	3.041	3.212	1.990	1.299	11.805	2.406	72.028	65.370	63.855	4,218	3,367	1.998	25.787	-2.733	1.648	4.413	0.616	70.53
800PJ350-97	1.671	17.065	4.266	3.195	2.782	1.290	16.974	3.711	111.105	107.517	104.925	10,888	6,034	5.762	36.082	-2.717	1.640	4.388	0.617	70.69
800PJ350-118	2.029	20.553	5.138	3.183	3.341	1.283	20.553	4.870	145.816	140.854	137.502	16,239	7,314	10.398	43.367	-2.705	1.633	4.370	0.617	70.88
1000PJ250-43 ¹	0.750	10.814	2.163	3.798	0.611	0.903	10.814	1.532	45.859	40.542	39.691	842	842	0.508	12.166	-1.696	1.072	4.257	0.841	51.47
1000PJ250-54	0.939	13.490	2.698	3.791	0.760	0.900	13.490	2.106	63.057	56.247	54.992	1,667	1,667	1.002	15.121	-1.690	1.068	4.247	0.842	51.40
1000PJ250-68	1.179	16.864	3.373	3.782	0.945	0.895	16.864	3.055	91.457	78.165	76.339	3,343	3,343	1.998	18.812	-1.682	1.064	4.235	0.842	51.32
1000PJ250-97	1.671	23.674	4.735	3.764	1.312	0.886	23.674	4.649	155.425	138.054	134.634	9,764	7,189	5.762	26.138	-1.666	1.055	4.210	0.843	51.19
1000PJ250-118	2.029	28.529	5.706	3.750	1.568	0.879	28.529	5.706	194.341	183.169	178.692	16,239	9,736	10.398	31.250	-1.653	1.048	4.192	0.844	51.13
1000PJ350-68	1.321	20.378	4.076	3.927	2.140	1.273	19.945	3.095	92.661	83.075	81.262	3,343	3,343	2.239	41.705	-2.513	1.545	4.833	0.730	69.88
1000PJ350-97	1.875	28.656	5.731	3.910	2.993	1.263	28.651	5.030	150.590	138.041	134.865	9,764	7,189	6.463	58.323	-2.497	1.536	4.808	0.730	69.87
1000PJ350-118	2.277	34.576	6.915	3.897	3.595	1.257	34.576	6.570	196.710	182.147	177.960	16,239	9,736	11.669	70.072	-2.485	1.530	4.790	0.731	69.90
1200PJ250-54 ¹	1.052	20.909	3.485	4.459	0.799	0.871	19.943	2.417	72.373	67.251	65.871	1,382	1,382	1.123	22.624	-1.550	0.995	4.800	0.896	50.62
1200PJ250-68	1.321	26.162	4.360	4.449	0.993	0.867	25.428	3.342	100.048	94.148	92.102	2,769	2,769	2.239	28.143	-1.542	0.991	4.788	0.896	50.51
1200PJ250-97	1.875	36.799	6.133	4.430	1.379	0.858	36.695	5.692	170.411	156.460	152.901	8,078	7,419	6.463	39.093	-1.526	0.981	4.764	0.897	50.29
1200PJ250-118	2.277	44.407	7.401	4.416	1.649	0.851	44.407	7.192	215.315	206.067	201.439	14,771	11,058	11.669	46.730	-1.514	0.974	4.746	0.898	50.15
1200PJ350-68	1.464	31.235	5.206	4.619	2.261	1.243	30.690	3.689	110.448	100.550	98.487	2,769	2,769	2.481	62.405	-2.330	1.456	5.320	0.808	69.28
1200PJ350-97	2.078	43.997	7.333	4.601	3.162	1.234	43.997	6.488	194.254	168.619	164.928	8,078	7,419	7.165	87.257	-2.314	1.447	5.296	0.809	69.16
1200PJ350-118	2.525	53.152	8.859	4.588	3.799	1.227	53.152	8.439	252.656	223.918	218.966	14,771	11,058	12.940	104.824	-2.301	1.440	5.278	0.810	69.10
1400PJ250-54 ¹	1.165	30.431	4.347	5.111	0.830	0.844	28.428	2.847	85.237	77.151	75.698	1,180	1,180	1.244	31.939	-1.433	0.932	5.375	0.929	49.87
1400PJ250-68	1.464	38.104	5.443	5.102	1.032	0.840	36.379	3.948	118.208	108.772	106.579	2,363	2,363	2.481	39.728	-1.425	0.928	5.363	0.929	49.73
1400PJ250-97	2.078	53.672	7.667	5.082	1.434	0.831	52.843	6.793	203.381	183.216	179.251	6,889	6,889	7.165	55.181	-1.410	0.918	5.339	0.930	49.46
1400PJ250-118	2.525	64.839	9.263	5.068	1.714	0.824	64.839	8.651	259.025	243.573	238.252	12,590	11,302	12.940	65.960	-1.398	0.912	5.321	0.931	49.27
1400PJ350-68	1.607	45.020	6.431	5.293	2.360	1.212	44.433	4.287	128.340	117.370	115.113	2,363	2,363	2.723	88.183	-2.174	1.378	5.850	0.862	68.66
1400PJ350-97	2.282	63.495	9.071	5.275	3.301	1.203	63.495	7.930	237.412	198.550	194.426	6,889	6,889	7.866	123.298	-2.158	1.369	5.825	0.863	68.47
1400PJ350-118	2.773	76.777	10.968	5.262	3.967	1.196	76.777	10.475	313.628	265.246	259.623	12,590	11,302	14.211	148.120	-2.146	1.362	5.807	0.863	68.35
1600PJ250-68 ¹	1.607	52.973	6.622	5.742	1.065	0.814	49.675	4.553	136.326	121.819	119.534	2,061	2,061	2.723	53.658	-1.326	0.873	5.949	0.950	48.97
1600PJ250-97	2.282	74.702	9.338	5.722	1.478	0.805	72.546	7.893	236.316	207.805	203.525	6,005	6,005	7.866	74.527	-1.311	0.864	5.925	0.951	48.66
1600PJ250-118	2.773	90.321	11.290	5.707	1.767	0.798	89.417	10.113	302.787	278.662	272.754	10,970	10,970	14.211	89.083	-1.300	0.857	5.908	0.952	48.43

¹Web-height-to-thickness ratio exceeds 200. Web stiffeners are required at all support points and concentric loads. Suitability of web holes must be evaluated independently.

Important Notes

- Spans are based on continuous support of compression flange over the full length of the joist.
- End shear and web crippling capacity have not been reduced for punchouts.
- Calculated allowable properties are based on AISI S100-16, "North American Specification for Design of Cold-Formed Steel Structural Members."
- For two equal spans, the listed span is the center-to-center distance from either end to the center support, with the joist continuous over the center support.
- Joists must be braced against rotation at all supports.
- End and interior web crippling checks are based on 3.5 inch bearing length. Joist flanges must be fastened to the support.
- Shear capacity at mid-span support has been reduced for the presence of punchouts adjacent to the support. Mid-span combined bending and shear check based on stiffened web.
- Deflection checks are computed using unbalanced loads for the two equal span condition.
- Total load deflection limited to $L/240$. Live load deflection limit as noted.
- " e " indicates that web stiffeners are required at the end supports only.
- " i " indicates that web stiffeners are required at the interior supports only.
- " a " indicates that web stiffeners are required at all the supports.
- Allowable flexural strength values in the tables are based on the minimum of local, distortional, and lateral-torsional buckling. Distortional buckling strength is based on a $k_{\phi} = 0$. Higher values may be obtained when sheathing is applied to the walls resulting in a higher k_{ϕ} value.

10 psf Dead Load and 20 psf Live Load												
Section (All Studs 50ksi)	Live Load Deflection L/360						Live Load Deflection L/480					
	Single Span Spacing (in.) o.c.			Two Equal Spans Spacing (in.) o.c.			Single Span Spacing (in.) o.c.			Two Equal Spans Spacing (in.) o.c.		
	12	16	24	12	16	24	12	16	24	12	16	24
600PJ250-43	19' 0"	17' 3"	15' 1"	21' 4" i	19' 5" i	16' 7" i	17' 3"	15' 8"	13' 8"	19' 5"	17' 7" i	15' 5" i
600PJ250-54	20' 6"	18' 8"	16' 3"	23' 1"	21' 0" i	18' 4" i	18' 8"	16' 11"	14' 10"	21' 0"	19' 1"	16' 8" i
600PJ250-68	22' 3"	20' 2"	17' 8"	25' 0"	22' 9"	19' 10"	20' 2"	18' 4"	16' 0"	22' 9"	20' 8"	18' 0"
600PJ250-97	24' 10"	22' 7"	19' 8"	27' 11"	25' 5"	22' 2"	22' 7"	20' 6"	17' 11"	25' 5"	23' 1"	20' 2"
600PJ250-118	26' 5"	24' 0"	20' 11"	29' 8"	27' 0"	23' 7"	24' 0"	21' 9"	19' 0"	27' 0"	24' 6"	21' 5"
600PJ350-68	23' 3"	21' 2"	18' 5"	26' 2"	23' 9"	20' 9" i	21' 2"	19' 2"	16' 9"	23' 9"	21' 7"	18' 10"
600PJ350-97	26' 7"	24' 2"	21' 1"	29' 11"	27' 2"	23' 9"	24' 2"	21' 11"	19' 2"	27' 2"	24' 8"	21' 7"
600PJ350-118	28' 5"	25' 10"	22' 7"	32' 0"	29' 1"	25' 5"	25' 10"	23' 6"	20' 6"	29' 1"	26' 5"	23' 1"
800PJ250-43	23' 9"	21' 7"	18' 8" e	26' 9" i	22' 8" i	17' 9" i	21' 7"	19' 7"	17' 2"	24' 3" i	22' 1" i	17' 9" i
800PJ250-54	25' 8"	23' 4"	20' 5"	28' 11" i	26' 3" i	22' 8" i	23' 4"	21' 3"	18' 6"	26' 3"	23' 10" i	20' 10" i
800PJ250-68	27' 10"	25' 4"	22' 1"	31' 4"	28' 5"	24' 10" i	25' 4"	23' 0"	20' 1"	28' 5"	25' 10"	22' 7"
800PJ250-97	31' 2"	28' 4"	24' 9"	35' 1"	31' 10"	27' 10"	28' 4"	25' 9"	22' 5"	31' 10"	28' 11"	25' 3"
800PJ250-118	33' 2"	30' 1"	26' 3"	37' 3"	33' 10"	29' 7"	30' 1"	27' 4"	23' 11"	33' 10"	30' 9"	26' 10"
800PJ350-68	29' 0"	26' 4"	23' 0"	32' 7"	29' 8"	25' 11" i	26' 4"	23' 11"	20' 11"	29' 8"	26' 11"	23' 6" i
800PJ350-97	33' 1"	30' 1"	26' 3"	37' 3"	33' 10"	29' 7"	30' 1"	27' 4"	23' 10"	33' 10"	30' 9"	26' 10"
800PJ350-118	35' 6"	32' 3"	28' 2"	39' 11"	36' 3"	31' 8"	32' 3"	29' 4"	25' 7"	36' 3"	33' 0"	28' 9"

Web Stiffener: Stud Segment on Back of Joist

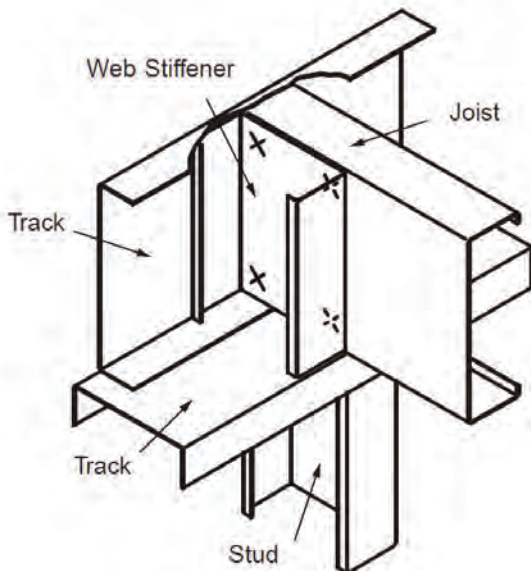

Web Stiffener: Track Inside Joist

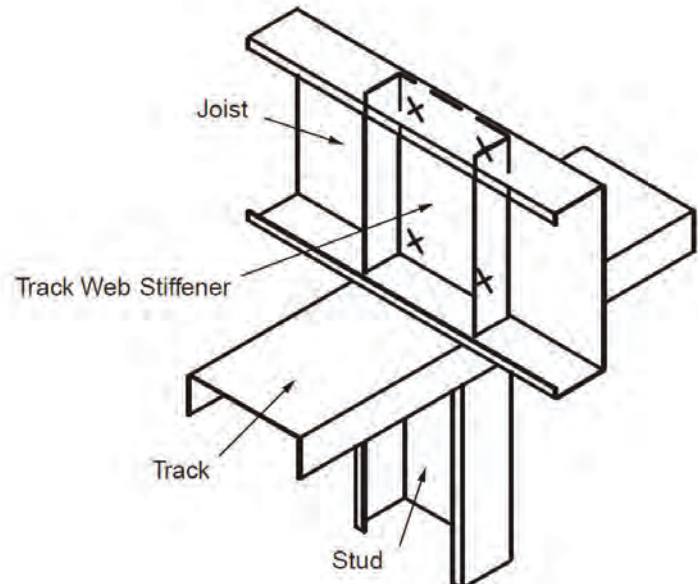

Refer to Important Table Notes on Page 53

10 psf Dead Load and 20 psf Live Load												
Section (All Studs 50ksi)	Live Load Deflection L/360						Live Load Deflection L/480					
	Single Span			Two Equal Spans			Single Span			Two Equal Spans		
	Spacing (in.) o.c.			Spacing (in.) o.c.			Spacing (in.) o.c.			Spacing (in.) o.c.		
	12	16	24	12	16	24	12	16	24	12	16	24
1000PJ250-43	27' 11"	25' 5"	21' 0" e	28' 2" i	23' 5" i	17' 8" i	25' 5"	23' 1"	20' 2" e	28' 2" i	23' 5" i	17' 8" i
1000PJ250-54	30' 8"	27' 10"	24' 4"	34' 6" i	30' 6" i	24' 2" i	27' 10"	25' 4"	22' 1"	31' 4" i	28' 6" i	24' 2" i
1000PJ250-68	33' 3"	30' 2"	26' 4"	37' 5"	34' 0" i	29' 8" i	30' 2"	27' 5"	23' 11"	34' 0"	30' 10"	26' 11" i
1000PJ250-97	37' 3"	33' 10"	29' 6"	41' 10"	38' 0"	33' 3"	33' 10"	30' 9"	26' 10"	38' 0"	34' 7"	30' 2"
1000PJ250-118	39' 7"	36' 0"	31' 5"	44' 7"	40' 6"	35' 4"	36' 0"	32' 8"	28' 7"	40' 6"	36' 9"	32' 1"
1000PJ350-68	34' 6"	31' 4"	27' 4"	38' 10"	35' 3" i	30' 9" i	31' 4"	28' 6"	24' 10"	35' 3"	32' 0"	28' 0" i
1000PJ350-97	39' 5"	35' 9"	31' 3"	44' 4"	40' 3"	35' 2"	35' 9"	32' 6"	28' 5"	40' 3"	36' 7"	31' 11"
1000PJ350-118	42' 3"	38' 4"	33' 6"	47' 6"	43' 2"	37' 8"	38' 4"	34' 10"	30' 5"	43' 2"	39' 3"	34' 3"
1200PJ250-54	34' 7"	31' 5"	27' 0" e	37' 3" i	31' 5" i	24' 6" i	31' 5"	28' 6"	24' 11"	35' 4" i	31' 5" i	24' 6" i
1200PJ250-68	37' 11"	34' 5"	30' 1"	42' 7" i	38' 9" i	31' 8" i	34' 5"	31' 3"	27' 4"	38' 9"	35' 2" i	30' 9" i
1200PJ250-97	43' 0"	39' 0"	34' 1"	48' 4"	43' 11"	38' 4"	39' 0"	35' 6"	31' 0"	43' 11"	39' 11"	34' 10"
1200PJ250-118	45' 11"	41' 9"	36' 5"	51' 8"	46' 11"	41' 0"	41' 9"	37' 11"	33' 1"	46' 11"	42' 7"	37' 3"
1200PJ350-68	39' 10"	36' 2"	31' 7"	44' 10" i	40' 8" i	33' 1" i	36' 2"	32' 10"	28' 8"	40' 8"	37' 0" i	32' 4" i
1200PJ350-97	45' 5"	41' 3"	36' 1"	51' 1"	46' 5"	40' 7" i	41' 3"	37' 6"	32' 9"	46' 5"	42' 2"	36' 10"
1200PJ350-118	48' 9"	44' 3"	38' 8"	54' 10"	49' 10"	43' 6"	44' 3"	40' 3"	35' 2"	49' 10"	45' 3"	39' 6"
1400PJ250-54	38' 10"	35' 3"	29' 0" e	38' 7" i	32' 2" i	24' 5" i	35' 3"	32' 0"	28' 0" e	38' 7" i	32' 2" i	24' 5" i
1400PJ250-68	42' 7"	38' 8"	33' 9"	47' 11" i	42' 0" i	33' 4" i	38' 8"	35' 2"	30' 8"	43' 6" i	39' 6" i	33' 4" i
1400PJ250-97	48' 5"	44' 0"	38' 5"	54' 6"	49' 6"	43' 3" i	44' 0"	40' 0"	34' 11"	49' 6"	45' 0"	39' 3"
1400PJ250-118	52' 0"	47' 3"	41' 3"	58' 6"	53' 1"	46' 5"	47' 3"	42' 11"	37' 6"	53' 1"	48' 3"	42' 2"
1400PJ350-68	44' 5"	40' 5"	35' 3"	50' 0" i	43' 6" i	34' 6" i	40' 5"	36' 8"	32' 1"	45' 5" i	41' 3" i	34' 6" i
1400PJ350-97	51' 4"	46' 8"	40' 9"	57' 9"	52' 6"	45' 10" i	46' 8"	42' 5"	37' 0"	52' 6"	47' 8"	41' 8"
1400PJ350-118	55' 1"	50' 1"	43' 9"	62' 0"	56' 4"	49' 2"	50' 1"	45' 6"	39' 9"	56' 4"	51' 2"	44' 8"
1600PJ250-68	47' 1"	42' 9"	36' 5"	51' 8" i	43' 10" i	34' 4" i	42' 9"	38' 10"	33' 11"	48' 1" i	43' 9" i	34' 4" i
1600PJ250-97	53' 8"	48' 10"	42' 7"	60' 5"	54' 11"	47' 11" i	48' 10"	44' 4"	38' 9"	54' 11"	49' 10"	43' 7" i
1600PJ250-118	57' 9"	52' 6"	45' 10"	64' 11"	59' 0"	51' 7"	52' 6"	47' 8"	41' 8"	59' 0"	53' 7"	46' 10"

Web Stiffener: Clip Angle

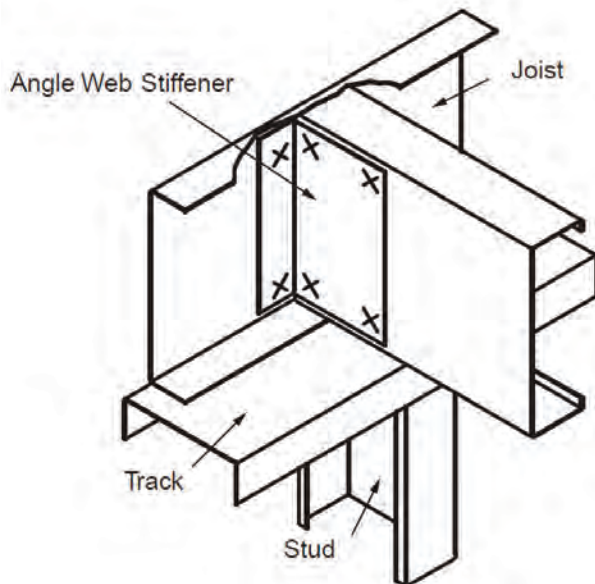

Web Stiffener: Joist Reinforcement

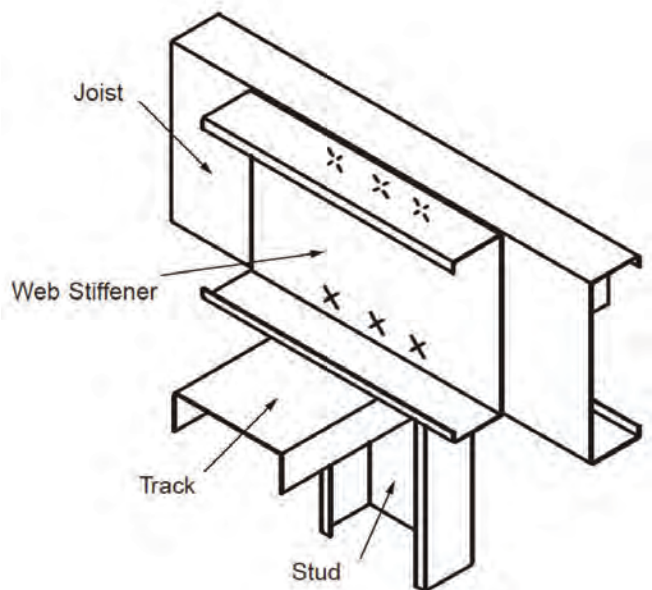

Refer to Important Table Notes on Page 53

10 psf Dead Load and 30 psf Live Load												
Section (All Studs 50ksi)	Live Load Deflection L/360						Live Load Deflection L/480					
	Single Span			Two Equal Spans			Single Span			Two Equal Spans		
	Spacing (in.) o.c.			Spacing (in.) o.c.			Spacing (in.) o.c.			Spacing (in.) o.c.		
	12	16	24	12	16	24	12	16	24	12	16	24
600PJ250-43	16' 7"	15' 1"	13' 2"	18' 8" i	16' 11" i	14' 1" i	15' 1"	13' 8"	11' 11"	16' 11" i	15' 5" i	13' 5" i
600PJ250-54	17' 11"	16' 3"	14' 3"	20' 2"	18' 4" i	16' 0" i	16' 3"	14' 10"	12' 11"	18' 4"	16' 8"	14' 6" i
600PJ250-68	19' 5"	17' 8"	15' 5"	21' 10"	19' 10"	17' 4" i	17' 8"	16' 0"	14' 0"	19' 10"	18' 0"	15' 9"
600PJ250-97	21' 8"	19' 8"	17' 3"	24' 5"	22' 2"	19' 4"	19' 8"	17' 11"	15' 8"	22' 2"	20' 2"	17' 7"
600PJ250-118	23' 1"	20' 11"	18' 3"	25' 11"	23' 7"	20' 7"	20' 11"	19' 0"	16' 7"	23' 7"	21' 5"	18' 8"
600PJ350-68	20' 4"	18' 5"	16' 1"	22' 10"	20' 9"	18' 2" i	18' 5"	16' 9"	14' 8"	20' 9"	18' 10"	16' 6"
600PJ350-97	23' 3"	21' 1"	18' 5"	26' 1"	23' 9"	20' 9"	21' 1"	19' 2"	16' 9"	23' 9"	21' 7"	18' 10"
600PJ350-118	24' 10"	22' 7"	19' 9"	27' 11"	25' 5"	22' 2"	22' 7"	20' 6"	17' 11"	25' 5"	23' 1"	20' 2"
800PJ250-43	20' 9"	18' 10"	16' 2" e	22' 8" i	19' 1" i	14' 9" i	18' 10"	17' 2"	14' 11" e	21' 3" i	19' 1" i	14' 9" i
800PJ250-54	22' 5"	20' 5"	17' 10"	25' 3" i	22' 11" i	19' 4" i	20' 5"	18' 6"	16' 2"	22' 11"	20' 10" i	18' 2" i
800PJ250-68	24' 4"	22' 1"	19' 4"	27' 4"	24' 10" i	21' 8" i	22' 1"	20' 1"	17' 6"	24' 10"	22' 7"	19' 9" i
800PJ250-97	27' 3"	24' 9"	21' 7"	30' 7"	27' 10"	24' 3"	24' 9"	22' 5"	19' 7"	27' 10"	25' 3"	22' 1"
800PJ250-118	28' 11"	26' 3"	23' 0"	32' 7"	29' 7"	25' 10"	26' 3"	23' 11"	20' 10"	29' 7"	26' 10"	23' 6"
800PJ350-68	25' 4"	23' 0"	20' 1"	28' 6"	25' 11" i	22' 7" i	23' 0"	20' 11"	18' 3"	25' 11"	23' 6"	20' 6" i
800PJ350-97	28' 11"	26' 3"	22' 11"	32' 7"	29' 7"	25' 10"	26' 3"	23' 10"	20' 10"	29' 7"	26' 10"	23' 5"
800PJ350-118	31' 0"	28' 2"	24' 7"	34' 11"	31' 8"	27' 8"	28' 2"	25' 7"	22' 4"	31' 8"	28' 9"	25' 2"
1000PJ250-43	24' 5"	22' 2" e	18' 2" e	23' 5" i	19' 3" i	14' 3" i	22' 2"	20' 2" e	17' 7" e	23' 5" i	19' 3" i	14' 3" i
1000PJ250-54	26' 9"	24' 4"	21' 3" e	30' 2" i	25' 11" i	20' 4" i	24' 4"	22' 1"	19' 4"	27' 5" i	24' 10" i	20' 4" i
1000PJ250-68	29' 0"	26' 4"	23' 0"	32' 8"	29' 8" i	25' 11" i	26' 4"	23' 11"	20' 11"	29' 8"	26' 11"	23' 6" i
1000PJ250-97	32' 6"	29' 6"	25' 10"	36' 7"	33' 3"	29' 0"	29' 6"	26' 10"	23' 5"	33' 3"	30' 2"	26' 4"
1000PJ250-118	34' 7"	31' 5"	27' 5"	38' 11"	35' 4"	30' 11"	31' 5"	28' 7"	24' 11"	35' 4"	32' 1"	28' 1"
1000PJ350-68	30' 2"	27' 4"	23' 11"	33' 11" i	30' 9" i	26' 7" i	27' 4"	24' 10"	21' 9"	30' 9"	28' 0" i	24' 5" i
1000PJ350-97	34' 5"	31' 3"	27' 3"	38' 8"	35' 2"	30' 8"	31' 3"	28' 5"	24' 10"	35' 2"	31' 11"	27' 11"
1000PJ350-118	36' 11"	33' 6"	29' 3"	41' 6"	37' 8"	32' 11"	33' 6"	30' 5"	26' 7"	37' 8"	34' 3"	29' 11"
1200PJ250-54	30' 2"	27' 5"	23' 5" e	31' 5" i	26' 4" i	20' 3" i	27' 5"	24' 11"	21' 9" e	30' 10" i	26' 4" i	20' 3" i
1200PJ250-68	33' 1"	30' 1"	26' 3"	37' 3" i	33' 9" i	26' 11" i	30' 1"	27' 4"	23' 10"	33' 10" i	30' 9" i	26' 10" i
1200PJ250-97	37' 6"	34' 1"	29' 9"	42' 3"	38' 4"	33' 6" i	34' 1"	31' 0"	27' 1"	38' 4"	34' 10"	30' 5"
1200PJ250-118	40' 1"	36' 5"	31' 10"	45' 1"	41' 0"	35' 10"	36' 5"	33' 1"	28' 11"	41' 0"	37' 3"	32' 6"
1200PJ350-68	34' 9"	31' 7"	27' 7"	39' 2" i	35' 4" i	28' 1" i	31' 7"	28' 8"	25' 1"	35' 7" i	32' 4" i	28' 1" i
1200PJ350-97	39' 8"	36' 1"	31' 6"	44' 8"	40' 7"	35' 5" i	36' 1"	32' 9"	28' 7"	40' 7"	36' 10"	32' 2"
1200PJ350-118	42' 7"	38' 8"	33' 9"	47' 11"	43' 6"	38' 0"	38' 8"	35' 2"	30' 8"	43' 6"	39' 6"	34' 6"
1400PJ250-54	33' 11"	30' 9" e	25' 1" e	32' 2" i	26' 6" i	19' 8" i	30' 9"	28' 0"	24' 5" e	32' 2" i	26' 6" i	19' 8" i
1400PJ250-68	37' 2"	33' 9"	29' 6"	41' 10" i	35' 8" i	28' 1" i	33' 9"	30' 8"	26' 10"	38' 0" i	34' 6" i	28' 1" i
1400PJ250-97	42' 4"	38' 5"	33' 7"	47' 7"	43' 3"	37' 9" i	38' 5"	34' 11"	30' 6"	43' 3"	39' 3"	34' 4" i
1400PJ250-118	45' 5"	41' 3"	36' 0"	51' 1"	46' 5"	40' 6"	41' 3"	37' 6"	32' 9"	46' 5"	42' 2"	36' 10"
1400PJ350-68	38' 10"	35' 3"	30' 10" e	43' 6" i	36' 11" i	29' 0" i	35' 3"	32' 1"	28' 0"	39' 8" i	36' 1" i	29' 0" i
1400PJ350-97	44' 10"	40' 9"	35' 7"	50' 6"	45' 10"	40' 1" i	40' 9"	37' 0"	32' 4"	45' 10"	41' 8"	36' 5" i
1400PJ350-118	48' 2"	43' 9"	38' 2"	54' 2"	49' 2"	43' 0"	43' 9"	39' 9"	34' 8"	49' 2"	44' 8"	39' 0"
1600PJ250-68	41' 2"	37' 4"	31' 6" e	43' 10" i	36' 11" i	28' 7" i	37' 4"	33' 11"	29' 8" e	42' 0" i	36' 11" i	28' 7" i
1600PJ250-97	46' 11"	42' 7"	37' 3"	52' 9"	47' 11" i	41' 11" i	42' 7"	38' 9"	33' 10"	47' 11"	43' 7"	38' 1" i
1600PJ250-118	50' 5"	45' 10"	40' 0"	56' 9"	51' 7"	45' 0" i	45' 10"	41' 8"	36' 4"	51' 7"	46' 10"	40' 11"

Refer to Important Table Notes on Page 53

10 psf Dead Load and 40 psf Live Load												
Section (All Studs 50ksi)	Live Load Deflection L/360						Live Load Deflection L/480					
	Single Span			Two Equal Spans			Single Span			Two Equal Spans		
	Spacing (in.) o.c.			Spacing (in.) o.c.			Spacing (in.) o.c.			Spacing (in.) o.c.		
	12	16	24	12	16	24	12	16	24	12	16	24
600PJ250-43	15' 1"	13' 8"	11' 11" e	16' 11" i	15' 5" i	12' 4" i	13' 8"	12' 5"	10' 10"	15' 5" i	14' 0" i	12' 2" i
600PJ250-54	16' 3"	14' 10"	12' 11"	18' 4" i	16' 8" i	14' 6" i	14' 10"	13' 5"	11' 9"	16' 8"	15' 1" i	13' 2" i
600PJ250-68	17' 8"	16' 0"	14' 0"	19' 10"	18' 0"	15' 9" i	16' 0"	14' 7"	12' 8"	18' 0"	16' 4"	14' 4" i
600PJ250-97	19' 8"	17' 11"	15' 8"	22' 2"	20' 2"	17' 7"	17' 11"	16' 3"	14' 2"	20' 2"	18' 4"	16' 0"
600PJ250-118	20' 11"	19' 0"	16' 7"	23' 7"	21' 5"	18' 8"	19' 0"	17' 3"	15' 1"	21' 5"	19' 5"	17' 0"
600PJ350-68	18' 5"	16' 9"	14' 8"	20' 9"	18' 10"	16' 6" i	16' 9"	15' 3"	13' 4"	18' 10"	17' 2"	15' 0" i
600PJ350-97	21' 1"	19' 2"	16' 9"	23' 9"	21' 7"	18' 10"	19' 2"	17' 5"	15' 2"	21' 7"	19' 7"	17' 1"
600PJ350-118	22' 7"	20' 6"	17' 11"	25' 5"	23' 1"	20' 2"	20' 6"	18' 8"	16' 3"	23' 1"	20' 11"	18' 4"
800PJ250-43	18' 10"	17' 2" e	14' 5" e	19' 10" i	16' 7" i	12' 8" i	17' 2"	15' 7"	13' 7" e	19' 3" i	16' 7" i	12' 8" i
800PJ250-54	20' 5"	18' 6"	16' 2"	22' 11" i	20' 10" i	17' 1" i	18' 6"	16' 10"	14' 8"	20' 10" i	18' 11" i	16' 6" i
800PJ250-68	22' 1"	20' 1"	17' 6"	24' 10"	22' 7" i	19' 9" i	20' 1"	18' 3"	15' 11"	22' 7"	20' 6"	17' 11" i
800PJ250-97	24' 9"	22' 5"	19' 7"	27' 10"	25' 3"	22' 1"	22' 5"	20' 5"	17' 10"	25' 3"	22' 11"	20' 0"
800PJ250-118	26' 3"	23' 11"	20' 10"	29' 7"	26' 10"	23' 6"	23' 11"	21' 8"	18' 11"	26' 10"	24' 5"	21' 4"
800PJ350-68	23' 0"	20' 11"	18' 3"	25' 11"	23' 6" i	20' 6" i	20' 11"	19' 0"	16' 7"	23' 6"	21' 4"	18' 8" i
800PJ350-97	26' 3"	23' 10"	20' 10"	29' 7"	26' 10"	23' 5"	23' 10"	21' 8"	18' 11"	26' 10"	24' 5"	21' 4"
800PJ350-118	28' 2"	25' 7"	22' 4"	31' 8"	28' 9"	25' 2"	25' 7"	23' 3"	20' 4"	28' 9"	26' 2"	22' 10"
1000PJ250-43	22' 2" e	19' 11" e	16' 3" e	20' 1" i	16' 4" i	11' 11" i	20' 2"	18' 3" e	16' 0" e	20' 1" i	16' 4" i	11' 11" i
1000PJ250-54	24' 4"	22' 1"	19' 1" e	26' 11" i	22' 9" i	17' 8" i	22' 1"	20' 1"	17' 6" e	24' 10" i	22' 7" i	17' 8" i
1000PJ250-68	26' 4"	23' 11"	20' 11"	29' 8" i	26' 11" i	23' 4" i	23' 11"	21' 9"	19' 0"	26' 11"	24' 6" i	21' 5" i
1000PJ250-97	29' 6"	26' 10"	23' 5"	33' 3"	30' 2"	26' 4"	26' 10"	24' 4"	21' 3"	30' 2"	27' 5"	23' 11"
1000PJ250-118	31' 5"	28' 7"	24' 11"	35' 4"	32' 1"	28' 1"	28' 7"	25' 11"	22' 8"	32' 1"	29' 2"	25' 6"
1000PJ350-68	27' 4"	24' 10"	21' 9"	30' 9" i	28' 0" i	23' 6" i	24' 10"	22' 7"	19' 9"	28' 0"	25' 5" i	22' 2" i
1000PJ350-97	31' 3"	28' 5"	24' 10"	35' 2"	31' 11"	27' 11" i	28' 5"	25' 9"	22' 6"	31' 11"	29' 0"	25' 4"
1000PJ350-118	33' 6"	30' 5"	26' 7"	37' 8"	34' 3"	29' 11"	30' 5"	27' 8"	24' 2"	34' 3"	31' 1"	27' 2"
1200PJ250-54	27' 5"	24' 11" e	20' 11" e	27' 5" i	22' 10" i	17' 3" i	24' 11"	22' 8"	19' 9" e	27' 5" i	22' 10" i	17' 3" i
1200PJ250-68	30' 1"	27' 4"	23' 10"	33' 10" i	29' 10" i	23' 8" i	27' 4"	24' 10"	21' 8"	30' 9" i	27' 11" i	23' 8" i
1200PJ250-97	34' 1"	31' 0"	27' 1"	38' 4"	34' 10"	30' 5" i	31' 0"	28' 2"	24' 7"	34' 10"	31' 8"	27' 8"
1200PJ250-118	36' 5"	33' 1"	28' 11"	41' 0"	37' 3"	32' 6"	33' 1"	30' 1"	26' 3"	37' 3"	33' 10"	29' 6"
1200PJ350-68	31' 7"	28' 8"	25' 1" e	35' 7" i	31' 2" i	24' 8" i	28' 8"	26' 1"	22' 9"	32' 4" i	29' 4" i	24' 8" i
1200PJ350-97	36' 1"	32' 9"	28' 7"	40' 7"	36' 10"	32' 2" i	32' 9"	29' 9"	26' 0"	36' 10"	33' 6"	29' 3" i
1200PJ350-118	38' 8"	35' 2"	30' 8"	43' 6"	39' 6"	34' 6"	35' 2"	31' 11"	27' 11"	39' 6"	35' 11"	31' 4"
1400PJ250-54	30' 9" e	27' 6" e	22' 5" e	27' 9" i	22' 7" i	16' 6" i	28' 0"	25' 5" e	22' 2" e	27' 9" i	22' 7" i	16' 6" i
1400PJ250-68	33' 9"	30' 8"	26' 7" e	37' 0" i	31' 4" i	24' 6" i	30' 8"	27' 11"	24' 4" e	34' 6" i	31' 4" i	24' 6" i
1400PJ250-97	38' 5"	34' 11"	30' 6"	43' 3"	39' 3" i	34' 4" i	34' 11"	31' 9"	27' 8"	39' 3"	35' 8"	31' 2" i
1400PJ250-118	41' 3"	37' 6"	32' 9"	46' 5"	42' 2"	36' 10" i	37' 6"	34' 1"	29' 9"	42' 2"	38' 4"	33' 5"
1400PJ350-68	35' 3"	32' 1"	27' 8" e	38' 4" i	32' 5" i	25' 2" i	32' 1"	29' 1"	25' 5" e	36' 1" i	32' 5" i	25' 2" i
1400PJ350-97	40' 9"	37' 0"	32' 4"	45' 10"	41' 8" i	36' 5" i	37' 0"	33' 8"	29' 5"	41' 8"	37' 10"	33' 1" i
1400PJ350-118	43' 9"	39' 9"	34' 8"	49' 2"	44' 8"	39' 0" i	39' 9"	36' 1"	31' 6"	44' 8"	40' 7"	35' 6"
1600PJ250-68	37' 4"	33' 11"	28' 2" e	38' 5" i	32' 2" i	24' 7" i	33' 11"	30' 10"	26' 11" e	38' 2" i	32' 2" i	24' 7" i
1600PJ250-97	42' 7"	38' 9"	33' 10"	47' 11"	43' 7" i	38' 0" i	38' 9"	35' 2"	30' 9"	43' 7"	39' 7"	34' 7" i
1600PJ250-118	45' 10"	41' 8"	36' 4"	51' 7"	46' 10"	40' 11" i	41' 8"	37' 10"	33' 0"	46' 10"	42' 7"	37' 2"

Refer to Important Table Notes on Page 53

10 psf Dead Load and 50 psf Live Load												
Section (All Studs 50ksi)	Live Load Deflection L/360						Live Load Deflection L/480					
	Single Span			Two Equal Spans			Single Span			Two Equal Spans		
	Spacing (in.) o.c.			Spacing (in.) o.c.			Spacing (in.) o.c.			Spacing (in.) o.c.		
	12	16	24	12	16	24	12	16	24	12	16	24
600PJ250-43	14' 0"	12' 8"	11' 1" e	15' 9" i	14' 1" i	11' 1" i	12' 8"	11' 6"	10' 1" e	14' 3" i	13' 0" i	11' 1" i
600PJ250-54	15' 1"	13' 9"	12' 0"	17' 0" i	15' 5" i	13' 6" i	13' 9"	12' 6"	10' 11"	15' 5"	14' 0" i	12' 3" i
600PJ250-68	16' 4"	14' 10"	13' 0"	18' 5"	16' 9" i	14' 7" i	14' 10"	13' 6"	11' 10"	16' 9"	15' 2"	13' 3" i
600PJ250-97	18' 3"	16' 7"	14' 6"	20' 7"	18' 8"	16' 4"	16' 7"	15' 1"	13' 2"	18' 8"	17' 0"	14' 10"
600PJ250-118	19' 5"	17' 8"	15' 5"	21' 10"	19' 10"	17' 4"	17' 8"	16' 0"	14' 0"	19' 10"	18' 0"	15' 9"
600PJ350-68	17' 2"	15' 7"	13' 7"	19' 3"	17' 6" i	15' 3" i	15' 7"	14' 2"	12' 4"	17' 6"	15' 11"	13' 11" i
600PJ350-97	19' 7"	17' 9"	15' 6"	22' 0"	20' 0"	17' 6"	17' 9"	16' 2"	14' 1"	20' 0"	18' 2"	15' 10"
600PJ350-118	20' 11"	19' 0"	16' 7"	23' 7"	21' 5"	18' 8"	19' 0"	17' 3"	15' 1"	21' 5"	19' 5"	17' 0"
800PJ250-43	17' 6"	15' 11" e	13' 2" e	17' 9" i	14' 9" i	11' 2" a	15' 11"	14' 5" e	12' 7" e	17' 9" i	14' 9" i	11' 2" a
800PJ250-54	18' 11"	17' 2"	15' 0" e	21' 4" i	19' 4" i	15' 4" i	17' 2"	15' 7"	13' 8"	19' 4" i	17' 7" i	15' 4" i
800PJ250-68	20' 6"	18' 8"	16' 3"	23' 1" i	20' 11" i	18' 4" i	18' 8"	16' 11"	14' 9"	20' 11"	19' 0" i	16' 7" i
800PJ250-97	22' 11"	20' 10"	18' 2"	25' 10"	23' 5"	20' 6"	20' 10"	18' 11"	16' 6"	23' 5"	21' 4"	18' 7"
800PJ250-118	24' 5"	22' 2"	19' 4"	27' 5"	24' 11"	21' 9"	22' 2"	20' 2"	17' 7"	24' 11"	22' 8"	19' 9"
800PJ350-68	21' 4"	19' 5"	16' 11"	24' 0" i	21' 10" i	19' 1" i	19' 5"	17' 7"	15' 5"	21' 10"	19' 10" i	17' 4" i
800PJ350-97	24' 5"	22' 2"	19' 4"	27' 5"	24' 11"	21' 9" i	22' 2"	20' 2"	17' 7"	24' 11"	22' 8"	19' 9"
800PJ350-118	26' 2"	23' 9"	20' 9"	29' 5"	26' 9"	23' 4"	23' 9"	21' 7"	18' 10"	26' 9"	24' 3"	21' 2"
1000PJ250-43	20' 7" e	18' 2" e	14' 0" e	17' 8" i	14' 3" i	10' 2" i	18' 8" e	17' 0" e	14' 0" e	17' 8" i	14' 3" i	10' 2" i
1000PJ250-54	22' 7"	20' 6"	17' 5" e	24' 2" i	20' 4" i	15' 8" i	20' 6"	18' 8"	16' 3" e	23' 1" i	20' 4" i	15' 8" i
1000PJ250-68	24' 6"	22' 3"	19' 5"	27' 6" i	25' 0" i	21' 1" i	22' 3"	20' 2"	17' 8"	25' 0"	22' 9" i	19' 10" i
1000PJ250-97	27' 5"	24' 11"	21' 9"	30' 10"	28' 0"	24' 6" i	24' 11"	22' 7"	19' 9"	28' 0"	25' 5"	22' 3"
1000PJ250-118	29' 2"	26' 6"	23' 2"	32' 10"	29' 10"	26' 0"	26' 6"	24' 1"	21' 0"	29' 10"	27' 1"	23' 8"
1000PJ350-68	25' 5"	23' 1"	20' 2"	28' 7" i	26' 0" i	21' 3" i	23' 1"	21' 0"	18' 4"	26' 0" i	23' 7" i	20' 7" i
1000PJ350-97	29' 0"	26' 4"	23' 0"	32' 8"	29' 8"	25' 11" i	26' 4"	23' 11"	20' 11"	29' 8"	26' 11"	23' 6"
1000PJ350-118	31' 1"	28' 3"	24' 8"	35' 0"	31' 9"	27' 9"	28' 3"	25' 8"	22' 5"	31' 9"	28' 11"	25' 3"
1200PJ250-54	25' 6"	23' 2" e	19' 1" e	24' 6" i	20' 3" i	15' 1" i	23' 2"	21' 0" e	18' 4" e	24' 6" i	20' 3" i	15' 1" i
1200PJ250-68	27' 11"	25' 4"	22' 2" e	31' 5" i	26' 11" i	21' 3" i	25' 4"	23' 0"	20' 1"	28' 6" i	25' 11" i	21' 3" i
1200PJ250-97	31' 8"	28' 9"	25' 1"	35' 7"	32' 4" i	28' 3" i	28' 9"	26' 1"	22' 10"	32' 4"	29' 5"	25' 8" i
1200PJ250-118	33' 10"	30' 9"	26' 10"	38' 0"	34' 7"	30' 2" i	30' 9"	27' 11"	24' 4"	34' 7"	31' 5"	27' 5"
1200PJ350-68	29' 4"	26' 8"	23' 3" e	33' 0" i	28' 1" i	22' 1" i	26' 8"	24' 2"	21' 2" e	30' 0" i	27' 3" i	22' 1" i
1200PJ350-97	33' 6"	30' 5"	26' 7"	37' 8"	34' 2" i	29' 11" i	30' 5"	27' 7"	24' 2"	34' 2"	31' 1"	27' 2" i
1200PJ350-118	35' 11"	32' 7"	28' 6"	40' 5"	36' 8"	32' 1" i	32' 7"	29' 8"	25' 11"	36' 8"	33' 4"	29' 1"
1400PJ250-54	28' 7" e	25' 1" e	19' 7" e	24' 5" i	19' 8" i	14' 2" i	25' 11" e	23' 7" e	19' 7" e	24' 5" i	19' 8" i	14' 2" i
1400PJ250-68	31' 4"	28' 6"	24' 3" e	33' 4" i	28' 1" i	21' 9" i	28' 6"	25' 11"	22' 7" e	32' 1" i	28' 1" i	21' 9" i
1400PJ250-97	35' 8"	32' 5"	28' 4"	40' 2"	36' 5" i	31' 10" i	32' 5"	29' 5"	25' 9"	36' 5"	33' 1"	28' 11" i
1400PJ250-118	38' 4"	34' 9"	30' 5"	43' 1"	39' 2"	34' 2" i	34' 9"	31' 7"	27' 7"	39' 2"	35' 7"	31' 1"
1400PJ350-68	32' 9"	29' 9"	25' 3" e	34' 6" i	29' 0" i	22' 4" i	29' 9"	27' 0"	23' 7" e	33' 6" i	29' 0" i	22' 4" i
1400PJ350-97	37' 10"	34' 5"	30' 0"	42' 7"	38' 8" i	33' 9" i	34' 5"	31' 3"	27' 3"	38' 8"	35' 2"	30' 8" i
1400PJ350-118	40' 7"	36' 11"	32' 3"	45' 8"	41' 6"	36' 3" i	36' 11"	33' 6"	29' 3"	41' 6"	37' 8"	32' 11"
1600PJ250-68	34' 8"	31' 6" e	25' 9" e	34' 4" i	28' 7" i	21' 7" i	31' 6"	28' 7"	25' 0" e	34' 4" i	28' 7" i	21' 7" i
1600PJ250-97	39' 7"	35' 11"	31' 5"	44' 6" i	40' 5" i	34' 5" i	35' 11"	32' 8"	28' 6"	40' 5"	36' 9" i	32' 1" i
1600PJ250-118	42' 6"	38' 8"	33' 9"	47' 10"	43' 6"	38' 0" i	38' 8"	35' 1"	30' 8"	43' 6"	39' 6"	34' 6" i

Refer to Important Table Notes on Page 53

15 psf Dead Load and 125 psf Live Load												
Section (All Studs 50ksi)	Live Load Deflection L/360						Live Load Deflection L/480					
	Single Span			Two Equal Spans			Single Span			Two Equal Spans		
	Spacing (in.) o.c.			Spacing (in.) o.c.			Spacing (in.) o.c.			Spacing (in.) o.c.		
	12	16	24	12	16	24	12	16	24	12	16	24
600PJ250-43	10' 3" e	9' 0" e	7' 4" e	10' 1" a	8' 5" a	6' 4" a	9' 4" e	8' 6" e	7' 4" e	10' 1" a	8' 5" a	6' 4" a
600PJ250-54	11' 2"	10' 1" e	8' 7" e	12' 5" i	10' 7" i	8' 5" a	10' 1"	9' 2"	8' 0" e	11' 5" i	10' 4" i	8' 5" a
600PJ250-68	12' 1"	10' 11"	9' 7"	13' 7" i	12' 4" i	10' 1" i	10' 11"	9' 11"	8' 8"	12' 4" i	11' 2" i	9' 9" i
600PJ250-97	13' 6"	12' 3"	10' 8"	15' 2"	13' 9"	12' 0" i	12' 3"	11' 1"	9' 8"	13' 9"	12' 6"	10' 11" i
600PJ250-118	14' 4"	13' 0"	11' 4"	16' 1"	14' 7"	12' 9"	13' 0"	11' 10"	10' 4"	14' 7"	13' 3"	11' 7"
600PJ350-68	12' 7"	11' 5"	10' 0" e	14' 2" i	12' 11" i	10' 5" i	11' 5"	10' 5"	9' 1"	12' 11" i	11' 8" i	10' 3" i
600PJ350-97	14' 5"	13' 1"	11' 5"	16' 3"	14' 9" i	12' 10" i	13' 1"	11' 11"	10' 5"	14' 9"	13' 4"	11' 8" i
600PJ350-118	15' 5"	14' 0"	12' 3"	17' 4"	15' 9"	13' 9" i	14' 0"	12' 9"	11' 1"	15' 9"	14' 4"	12' 6"
800PJ250-43	12' 3" e	10' 7" e	7' 6" e	9' 11" a	7' 11" a	5' 7" a	11' 8" e	10' 7" e	7' 6" e	9' 11" a	7' 11" a	5' 7" a
800PJ250-54	13' 11" e	12' 5" e	10' 1" e	14' 0" i	11' 8" a	8' 11" a	12' 8" e	11' 6" e	10' 0" e	14' 0" i	11' 8" a	8' 11" a
800PJ250-68	15' 1"	13' 9"	11' 11" e	17' 0" i	14' 10" i	11' 10" a	13' 9"	12' 5"	10' 11" e	15' 5" i	14' 0" i	11' 10" a
800PJ250-97	16' 11"	15' 4"	13' 5"	19' 0"	17' 3" i	15' 1" i	15' 4"	13' 11"	12' 2"	17' 3"	15' 8"	13' 8" i
800PJ250-118	18' 0"	16' 4"	14' 3"	20' 3"	18' 4"	16' 0" i	16' 4"	14' 10"	12' 11"	18' 4"	16' 8"	14' 7"
800PJ350-68	15' 9"	14' 3" e	12' 3" e	17' 8" i	15' 3" i	12' 2" a	14' 3"	13' 0"	11' 4" e	16' 1" i	14' 7" i	12' 2" a
800PJ350-97	18' 0"	16' 4"	14' 3"	20' 2" i	18' 4" i	15' 11" i	16' 4"	14' 10"	12' 11"	18' 4"	16' 8" i	14' 7" i
800PJ350-118	19' 3"	17' 6"	15' 3"	21' 8"	19' 8"	17' 2" i	17' 6"	15' 11"	13' 10"	19' 8"	17' 10"	15' 7" i
1000PJ250-43	12' 0" e	9' 0" e	6' 0" e	8' 11" a	6' 10" a	4' 8" a	12' 0" e	9' 0" e	6' 0" e	8' 11" a	6' 10" a	4' 8" a
1000PJ250-54	16' 2" e	14' 0" e	11' 5" e	14' 2" a	11' 6" a	8' 4" a	15' 1" e	13' 9" e	11' 5" e	14' 2" a	11' 6" a	8' 4" a
1000PJ250-68	18' 0"	16' 4" e	13' 5" e	19' 4" i	16' 4" a	12' 8" a	16' 4"	14' 10" e	13' 0" e	18' 5" i	16' 4" a	12' 8" a
1000PJ250-97	20' 2"	18' 4"	16' 0"	22' 9" i	20' 8" i	18' 0" i	18' 4"	16' 8"	14' 7"	20' 8"	18' 9" i	16' 4" i
1000PJ250-118	21' 6"	19' 6"	17' 1"	24' 2"	21' 11" i	19' 2" i	19' 6"	17' 9"	15' 6"	21' 11"	19' 11"	17' 5" i
1000PJ350-68	18' 8" e	17' 0" e	13' 10" e	19' 5" i	16' 5" a	12' 9" a	17' 0"	15' 5" e	13' 6" e	19' 1" i	16' 5" a	12' 9" a
1000PJ350-97	21' 4"	19' 5"	16' 11"	24' 0" i	21' 10" i	18' 4" i	19' 5"	17' 7"	15' 5"	21' 10" i	19' 10" i	17' 4" i
1000PJ350-118	22' 11"	20' 10"	18' 2"	25' 9"	23' 5" i	20' 5" i	20' 10"	18' 11"	16' 6"	23' 5"	21' 3"	18' 7" i
1200PJ250-54	17' 8" e	14' 9" e	9' 10" e	13' 5" a	10' 7" a	7' 5" a	17' 0" e	14' 9" e	9' 10" e	13' 5" a	10' 7" a	7' 5" a
1200PJ250-68	20' 7" e	18' 1" e	14' 9" e	19' 4" i	16' 2" a	12' 3" a	18' 8" e	16' 11" e	14' 9" e	19' 4" i	16' 2" a	12' 3" a
1200PJ250-97	23' 4"	21' 2"	18' 6" e	26' 3" i	23' 10" i	19' 2" i	21' 2"	19' 3"	16' 10"	23' 10" i	21' 8" i	18' 11" i
1200PJ250-118	24' 11"	22' 7"	19' 9"	28' 0" i	25' 5" i	22' 2" i	22' 7"	20' 7"	17' 11"	25' 5"	23' 1" i	20' 2" i
1200PJ350-68	21' 7" e	18' 9" e	15' 3" e	20' 1" i	16' 8" a	12' 7" a	19' 7" e	17' 10" e	15' 3" e	20' 1" i	16' 8" a	12' 7" a
1200PJ350-97	24' 8"	22' 5"	19' 7" e	27' 9" i	25' 2" i	20' 4" a	22' 5"	20' 4"	17' 9" e	25' 2" i	22' 11" i	20' 0" i
1200PJ350-118	26' 5"	24' 0"	21' 0"	29' 9" i	27' 0" i	23' 7" i	24' 0"	21' 10"	19' 1"	27' 0"	24' 7" i	21' 5" i
1400PJ250-54	16' 10" e	12' 7" e	8' 5" e	12' 5" i	9' 7" a	6' 7" a	16' 10" e	12' 7" e	8' 5" e	12' 5" i	9' 7" a	6' 7" a
1400PJ250-68	22' 6" e	19' 6" e	15' 11" e	19' 7" i	16' 0" a	11' 9" a	21' 0" e	19' 1" e	15' 11" e	19' 7" i	16' 0" a	11' 9" a
1400PJ250-97	26' 3"	23' 10"	20' 7" e	29' 7" i	25' 7" i	20' 4" a	23' 10"	21' 8"	18' 11" e	26' 10" i	24' 5" i	20' 4" a
1400PJ250-118	28' 2"	25' 7"	22' 5"	31' 9" i	28' 10" i	24' 1" i	25' 7"	23' 3"	20' 4"	28' 10"	26' 2" i	22' 10" i
1400PJ350-68	23' 4" e	20' 3" e	16' 6" e	20' 1" a	16' 4" a	11' 11" a	21' 11" e	19' 11" e	16' 6" e	20' 1" a	16' 4" a	11' 11" a
1400PJ350-97	27' 10"	25' 4"	21' 6" e	31' 4" i	27' 4" i	21' 8" a	25' 4"	23' 0"	20' 1" e	28' 6" i	25' 10" i	21' 8" a
1400PJ350-118	29' 11"	27' 2"	23' 9"	33' 8" i	30' 7" i	26' 4" i	27' 2"	24' 8"	21' 7"	30' 7"	27' 9" i	24' 3" i
1600PJ250-68	23' 10" e	20' 7" e	14' 8" e	19' 3" i	15' 5" a	10' 11" a	23' 2" e	20' 7" e	14' 8" e	19' 3" i	15' 5" a	10' 11" a
1600PJ250-97	29' 2"	26' 6" e	22' 0" e	31' 7" i	26' 10" i	21' 0" a	26' 6"	24' 1"	21' 0" e	29' 9" i	26' 10" i	21' 0" a
1600PJ250-118	31' 4"	28' 6"	24' 10" e	35' 3" i	31' 10" i	25' 7" i	28' 6"	25' 10"	22' 7"	32' 0" i	29' 1" i	25' 5" i

Refer to Important Table Notes on Page 53

40 psf Dead Load and 125 psf Live Load												
Section (All Studs 50ksi)	Live Load Deflection L/360						Live Load Deflection L/480					
	Single Span			Two Equal Spans			Single Span			Two Equal Spans		
	Spacing (in.) o.c.			Spacing (in.) o.c.			Spacing (in.) o.c.			Spacing (in.) o.c.		
	12	16	24	12	16	24	12	16	24	12	16	24
600PJ250-43	9' 7" e	8' 4" e	6' 9" e	9' 1" a	7' 6" a	5' 7" a	9' 4" e	8' 4" e	6' 9" e	9' 1" a	7' 6" a	5' 7" a
600PJ250-54	11' 2" e	9' 9" e	7' 11" e	11' 4" i	9' 8" a	7' 8" a	10' 1" e	9' 2" e	7' 11" e	11' 4" i	9' 8" a	7' 8" a
600PJ250-68	12' 1" e	10' 11" e	9' 3" e	13' 4" i	11' 5" i	9' 3" i	10' 11" e	9' 11" e	8' 8" e	12' 4" i	11' 2" i	9' 3" i
600PJ250-97	13' 6" e	12' 3" e	10' 8" e	15' 2" e	13' 9" i	12' 0" i	12' 3" e	11' 1" e	9' 8" e	13' 9" e	12' 6" e	10' 11" i
600PJ250-118	14' 4" e	13' 0" e	11' 4" e	16' 1" e	14' 7" e	12' 9" i	13' 0" e	11' 10" e	10' 4" e	14' 7" e	13' 3" e	11' 7" e
600PJ350-68	12' 7" e	11' 5" e	9' 8" e	13' 9" i	11' 10" i	9' 6" i	11' 5" e	10' 5" e	9' 1" e	12' 11" i	11' 8" i	9' 6" i
600PJ350-97	14' 5" e	13' 1" e	11' 5" e	16' 3" i	14' 9" i	12' 2" i	13' 1" e	11' 11" e	10' 5" e	14' 9" e	13' 4" i	11' 8" i
600PJ350-118	15' 5" e	14' 0" e	12' 3" e	17' 4" e	15' 9" i	13' 9" i	14' 0" e	12' 9" e	11' 1" e	15' 9" e	14' 4" e	12' 6" i
800PJ250-43	11' 3" e	9' 7" e	6' 5" e	8' 9" a	6' 11" a	4' 10" a	11' 3" e	9' 7" e	6' 5" e	8' 9" a	6' 11" a	4' 10" a
800PJ250-54	13' 2" e	11' 5" e	9' 4" e	12' 8" a	10' 6" a	7' 11" a	12' 8" e	11' 5" e	9' 4" e	12' 8" a	10' 6" a	7' 11" a
800PJ250-68	15' 1" e	13' 5" e	10' 11" e	15' 10" i	13' 6" i	10' 9" a	13' 9" e	12' 5" e	10' 11" e	15' 5" i	13' 6" i	10' 9" a
800PJ250-97	16' 11" e	15' 4" e	13' 5" e	19' 0" i	17' 3" i	14' 10" i	15' 4" e	13' 11" e	12' 2" e	17' 3" e	15' 8" i	13' 8" i
800PJ250-118	18' 0" e	16' 4" e	14' 3" e	20' 3" e	18' 4" i	16' 0" i	16' 4" e	14' 10" e	12' 11" e	18' 4" e	16' 8" e	14' 7" i
800PJ350-68	15' 9" e	13' 10" e	11' 4" e	16' 4" i	13' 11" i	11' 0" a	14' 3" e	13' 0" e	11' 4" e	16' 1" i	13' 11" i	11' 0" a
800PJ350-97	18' 0" e	16' 4" e	14' 3" e	20' 2" i	18' 1" i	14' 8" i	16' 4" e	14' 10" e	12' 11" e	18' 4" i	16' 8" i	14' 7" i
800PJ350-118	19' 3" e	17' 6" e	15' 3" e	21' 8" i	19' 8" i	16' 11" i	17' 6" e	15' 11" e	13' 10" e	19' 8" e	17' 10" e	15' 7" i
1000PJ250-43	10' 2" e	7' 7" e	5' 1" e	7' 8" a	5' 11" a	4' 0" a	10' 2" e	7' 7" e	5' 1" e	7' 8" a	5' 11" a	4' 0" a
1000PJ250-54	14' 10" e	12' 10" e	10' 1" e	12' 7" a	10' 2" a	7' 3" a	14' 10" e	12' 10" e	10' 1" e	12' 7" a	10' 2" a	7' 3" a
1000PJ250-68	17' 6" e	15' 2" e	12' 5" e	17' 7" i	14' 9" a	11' 5" a	16' 4" e	14' 10" e	12' 5" e	17' 7" i	14' 9" a	11' 5" a
1000PJ250-97	20' 2" e	18' 4" e	16' 0" e	22' 9" i	20' 8" i	17' 1" i	18' 4" e	16' 8" e	14' 7" e	20' 8" i	18' 9" i	16' 4" i
1000PJ250-118	21' 6" e	19' 6" e	17' 1" e	24' 2" i	21' 11" i	19' 2" i	19' 6" e	17' 9" e	15' 6" e	21' 11" i	19' 11" i	17' 5" i
1000PJ350-68	18' 1" e	15' 8" e	12' 9" e	17' 8" i	14' 10" a	11' 5" a	17' 0" e	15' 5" e	12' 9" e	17' 8" i	14' 10" a	11' 5" a
1000PJ350-97	21' 4" e	19' 5" e	16' 6" e	24' 0" i	20' 10" i	16' 10" i	19' 5" e	17' 7" e	15' 5" e	21' 10" i	19' 10" i	16' 10" i
1000PJ350-118	22' 11" e	20' 10" e	18' 2" e	25' 9" i	23' 5" i	19' 7" i	20' 10" e	18' 11" e	16' 6" e	23' 5" i	21' 3" i	18' 7" i
1200PJ250-54	16' 3" e	12' 6" e	8' 4" e	11' 9" a	9' 3" a	6' 5" a	16' 3" e	12' 6" e	8' 4" e	11' 9" a	9' 3" a	6' 5" a
1200PJ250-68	19' 3" e	16' 8" e	13' 7" e	17' 6" i	14' 6" a	10' 10" a	18' 8" e	16' 8" e	13' 7" e	17' 6" i	14' 6" a	10' 10" a
1200PJ250-97	23' 4" e	21' 2" e	17' 6" e	25' 6" i	21' 10" i	17' 6" a	21' 2" e	19' 3" e	16' 10" e	23' 10" i	21' 8" i	17' 6" a
1200PJ250-118	24' 11" e	22' 7" e	19' 9" e	28' 0" i	25' 2" i	20' 5" i	22' 7" e	20' 7" e	17' 11" e	25' 5" i	23' 1" i	20' 2" i
1200PJ350-68	19' 11" e	17' 3" e	14' 1" e	18' 1" a	14' 11" a	11' 1" a	19' 7" e	17' 3" e	14' 1" e	18' 1" a	14' 11" a	11' 1" a
1200PJ350-97	24' 8" e	22' 4" e	18' 3" e	27' 1" i	23' 3" i	18' 7" a	22' 5" e	20' 4" e	17' 9" e	25' 2" i	22' 11" i	18' 7" a
1200PJ350-118	26' 5" e	24' 0" e	21' 0" e	29' 9" i	27' 0" i	22' 0" i	24' 0" e	21' 10" e	19' 1" e	27' 0" i	24' 7" i	21' 5" i
1400PJ250-54	14' 3" e	10' 8" e	7' 1" e	10' 9" i	8' 3" a	5' 7" a	14' 3" e	10' 8" e	7' 1" e	10' 9" i	8' 3" a	5' 7" a
1400PJ250-68	20' 9" e	17' 11" e	14' 3" e	17' 6" a	14' 2" a	10' 3" a	20' 9" e	17' 11" e	14' 3" e	17' 6" a	14' 2" a	10' 3" a
1400PJ250-97	26' 3" e	23' 3" e	19' 0" e	27' 4" i	23' 4" i	18' 5" a	23' 10" e	21' 8" e	18' 11" e	26' 10" i	23' 4" i	18' 5" a
1400PJ250-118	28' 2" e	25' 7" e	21' 11" e	31' 9" i	27' 4" i	22' 1" i	25' 7" e	23' 3" e	20' 4" e	28' 10" i	26' 2" i	22' 1" i
1400PJ350-68	21' 6" e	18' 8" e	14' 3" e	17' 11" a	14' 5" a	10' 4" a	21' 6" e	18' 8" e	14' 3" e	17' 11" a	14' 5" a	10' 4" a
1400PJ350-97	27' 10" e	24' 3" e	19' 9" e	29' 4" i	24' 11" i	19' 8" a	25' 4" e	23' 0" e	19' 9" e	28' 6" i	24' 11" i	19' 8" a
1400PJ350-118	29' 11" e	27' 2" e	22' 10" e	33' 8" i	29' 11" i	24' 1" i	27' 2" e	24' 8" e	21' 7" e	30' 7" i	27' 9" i	24' 1" i
1600PJ250-68	21' 11" e	18' 8" e	12' 5" e	17' 0" a	13' 5" a	9' 5" a	21' 11" e	18' 8" e	12' 5" e	17' 0" a	13' 5" a	9' 5" a
1600PJ250-97	28' 8" e	24' 10" e	20' 3" e	28' 9" i	24' 4" i	19' 0" a	26' 6" e	24' 1" e	20' 3" e	28' 9" i	24' 4" i	19' 0" a
1600PJ250-118	31' 4" e	28' 6" e	23' 5" e	34' 0" i	29' 2" i	23' 5" i	28' 6" e	25' 10" e	22' 7" e	32' 0" i	29' 1" i	23' 5" i

Important Notes

1. All capacities listed are calculated using AISI S100-16.
2. Web crippling capacities calculated are for studs with stiffened or partially stiffened flanges.
3. Tabulated web crippling capacities are for single members only. For multiple members, multiply the tabulated values by number of members in the assembly.
4. Listed allowable capacities are based on members 'fastened to supports', except back-to-back members under two-flange loading (condition 3 and 4) for which data for 'fastened to support' is unavailable in the AISI S100-16.
5. Listed allowable capacities are for unpunched webs. Capacity reduction for end and interior one flange loading (conditions 1 and 2) near punchouts may be required per Section G6 of AISI S100-16.

Web Crippling Conditions

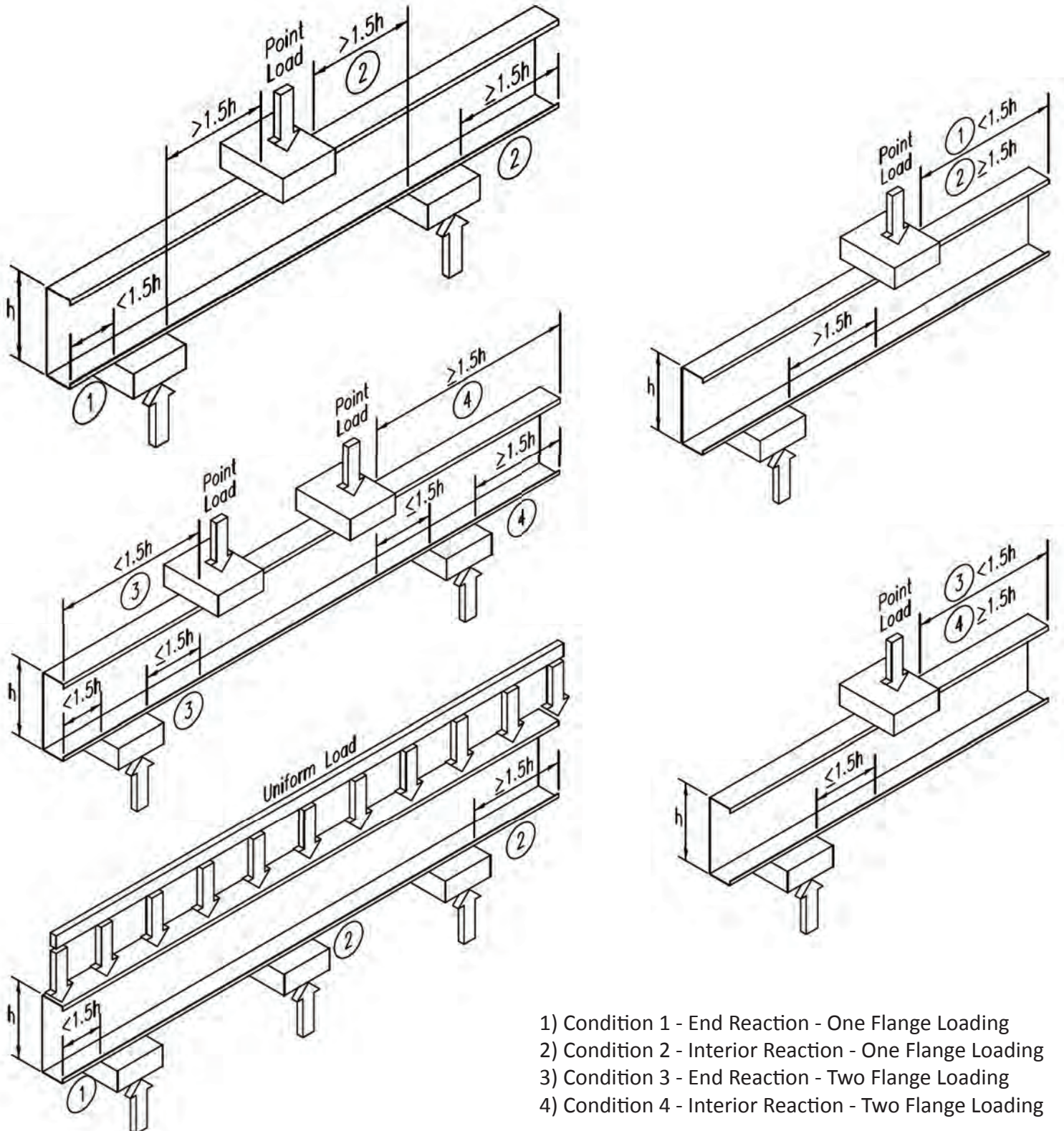

- 1) Condition 1 - End Reaction - One Flange Loading
- 2) Condition 2 - Interior Reaction - One Flange Loading
- 3) Condition 3 - End Reaction - Two Flange Loading
- 4) Condition 4 - Interior Reaction - Two Flange Loading

Refer to Important Table Notes on Page 60

Allowable Web Crippling Loads (lbs) - Single Members																		
Section (All Studs 50ksi)	Design Thick- ness (in.)	Inside Radius (in.)	Condition 1				Condition 2				Condition 3				Condition 4			
			1	3.5	4	6	1	3.5	4	6	1	3.5	4	6	1	3.5	4	6
600PJ250-43	0.0451	0.105	375	579	609	714	766	1,031	1,070	1,207	276	362	375	420	883	1,094	1,125	1,234
600PJ250-54	0.0566	0.105	586	889	934	1,091	1,239	1,638	1,698	1,904	478	617	638	710	1,457	1,776	1,824	1,988
600PJ250-68	0.0713	0.105	916	1,369	1,436	1,669	2,005	2,605	2,694	3,004	817	1,037	1,070	1,184	2,402	2,884	2,956	3,205
600PJ250-97	0.1017	0.105	1,811	2,637	2,759	3,185	4,160	5,265	5,429	5,999	1,805	2,235	2,299	2,521	5,116	6,009	6,142	6,603
600PJ250-118	0.1242	0.105	2,652	3,803	3,974	4,568	6,248	7,795	8,024	8,823	2,789	3,406	3,497	3,816	7,787	9,042	9,228	9,876
600PJ350-68	0.0713	0.105	916	1,369	1,436	1,669	2,005	2,605	2,694	3,004	817	1,037	1,070	1,184	2,402	2,884	2,956	3,205
600PJ350-97	0.1017	0.105	1,811	2,637	2,759	3,185	4,160	5,265	5,429	5,999	1,805	2,235	2,299	2,521	5,116	6,009	6,142	6,603
600PJ350-118	0.1242	0.105	2,652	3,803	3,974	4,568	6,248	7,795	8,024	8,823	2,789	3,406	3,497	3,816	7,787	9,042	9,228	9,876
800PJ250-43	0.0451	0.105	358	551	580	680	750	1,010	1,048	1,182	223	293	304	340	807	999	1,027	1,127
800PJ250-54	0.0566	0.105	562	853	896	1,046	1,216	1,609	1,667	1,869	406	524	542	603	1,350	1,646	1,690	1,843
800PJ250-68	0.0713	0.105	884	1,320	1,385	1,610	1,973	2,564	2,651	2,956	717	911	939	1,039	2,252	2,704	2,771	3,005
800PJ250-97	0.1017	0.105	1,759	2,561	2,680	3,094	4,105	5,195	5,357	5,920	1,641	2,031	2,089	2,291	4,863	5,713	5,839	6,277
800PJ250-118	0.1242	0.105	2,584	3,706	3,872	4,451	6,173	7,702	7,929	8,718	2,570	3,138	3,222	3,516	7,449	8,649	8,827	9,446
800PJ350-68	0.0713	0.105	884	1,320	1,385	1,610	1,973	2,564	2,651	2,956	717	911	939	1,039	2,252	2,704	2,771	3,005
800PJ350-97	0.1017	0.105	1,759	2,561	2,680	3,094	4,105	5,195	5,357	5,920	1,641	2,031	2,089	2,291	4,863	5,713	5,839	6,277
800PJ350-118	0.1242	0.105	2,584	3,706	3,872	4,451	6,173	7,702	7,929	8,718	2,570	3,138	3,222	3,516	7,449	8,649	8,827	9,446
1000PJ250-43	0.0451	0.105	342	527	555	651	736	991	1,029	1,160	177	233	241	270	740	916	942	1,033
1000PJ250-54	0.0566	0.105	541	821	863	1,007	1,197	1,583	1,640	1,839	343	443	458	509	1,257	1,532	1,573	1,715
1000PJ250-68	0.0713	0.105	855	1,278	1,340	1,558	1,945	2,527	2,614	2,914	630	800	825	913	2,121	2,547	2,610	2,830
1000PJ250-97	0.1017	0.105	1,714	2,495	2,610	3,013	4,057	5,134	5,294	5,851	1,496	1,853	1,906	2,089	4,643	5,453	5,574	5,992
1000PJ250-118	0.1242	0.105	2,525	3,620	3,783	4,348	6,108	7,621	7,845	8,626	2,378	2,904	2,982	3,254	7,153	8,305	8,476	9,071
1000PJ350-68	0.0713	0.105	855	1,278	1,340	1,558	1,945	2,527	2,614	2,914	630	800	825	913	2,121	2,547	2,610	2,830
1000PJ350-97	0.1017	0.105	1,714	2,495	2,610	3,013	4,057	5,134	5,294	5,851	1,496	1,853	1,906	2,089	4,643	5,453	5,574	5,992
1000PJ350-118	0.1242	0.105	2,525	3,620	3,783	4,348	6,108	7,621	7,845	8,626	2,378	2,904	2,982	3,254	7,153	8,305	8,476	9,071
1200PJ250-54	0.0566	0.105	522	792	833	972	1,179	1,559	1,616	1,812	286	369	382	425	1,172	1,429	1,467	1,600
1200PJ250-68	0.0713	0.105	830	1,239	1,300	1,512	1,919	2,494	2,580	2,876	551	700	722	799	2,003	2,405	2,465	2,672
1200PJ250-97	0.1017	0.105	1,673	2,435	2,548	2,941	4,013	5,080	5,238	5,788	1,367	1,692	1,740	1,908	4,444	5,220	5,335	5,736
1200PJ250-118	0.1242	0.105	2,471	3,543	3,703	4,256	6,050	7,548	7,770	8,543	2,206	2,693	2,766	3,018	6,886	7,996	8,160	8,733
1200PJ350-68	0.0713	0.105	830	1,239	1,300	1,512	1,919	2,494	2,580	2,876	551	700	722	799	2,003	2,405	2,465	2,672
1200PJ350-97	0.1017	0.105	1,673	2,435	2,548	2,941	4,013	5,080	5,238	5,788	1,367	1,692	1,740	1,908	4,444	5,220	5,335	5,736
1200PJ350-118	0.1242	0.105	2,471	3,543	3,703	4,256	6,050	7,548	7,770	8,543	2,206	2,693	2,766	3,018	6,886	7,996	8,160	8,733
1400PJ250-54	0.0566	0.105	505	766	805	940	1,163	1,538	1,593	1,787	234	302	312	347	1,095	1,335	1,370	1,494
1400PJ250-68	0.0713	0.105	806	1,204	1,263	1,469	1,896	2,464	2,548	2,842	479	608	627	694	1,894	2,275	2,331	2,528
1400PJ250-97	0.1017	0.105	1,635	2,380	2,491	2,875	3,974	5,029	5,186	5,731	1,248	1,545	1,589	1,742	4,262	5,006	5,117	5,501
1400PJ250-118	0.1242	0.105	2,422	3,473	3,629	4,171	5,996	7,481	7,701	8,467	2,048	2,501	2,568	2,801	6,642	7,712	7,871	8,423
1400PJ350-68	0.0713	0.105	806	1,204	1,263	1,469	1,896	2,464	2,548	2,842	479	608	627	694	1,894	2,275	2,331	2,528
1400PJ350-97	0.1017	0.105	1,635	2,380	2,491	2,875	3,974	5,029	5,186	5,731	1,248	1,545	1,589	1,742	4,262	5,006	5,117	5,501
1400PJ350-118	0.1242	0.105	2,422	3,473	3,629	4,171	5,996	7,481	7,701	8,467	2,048	2,501	2,568	2,801	6,642	7,712	7,871	8,423
1600PJ250-68	0.0713	0.105	784	1,172	1,229	1,429	1,875	2,436	2,519	2,809	412	523	540	597	1,794	2,154	2,207	2,393
1600PJ250-97	0.1017	0.105	1,600	2,329	2,437	2,814	3,937	4,983	5,138	5,678	1,137	1,408	1,448	1,588	4,093	4,808	4,914	5,283
1600PJ250-118	0.1242	0.105	2,377	3,408	3,561	4,093	5,946	7,418	7,637	8,397	1,901	2,321	2,384	2,601	6,415	7,449	7,602	8,136

¹ Bearing length to web height ratio, N/h, exceeds limit of 2.0.

² Bearing length to thickness ratio, N/t, exceeds limit of 210.

Refer to Important Table Notes on Page 60

Allowable Web Crippling Loads (lbs) - Back-to-Back Members																		
Section (All Studs 50ksi)	Design Thick- ness (in.)	Inside Radius (in.)	Condition 1				Condition 2				Condition 3				Condition 4			
			1	3.5	4	6	1	3.5	4	6	1	3.5	4	6	1	3.5	4	6
600PJ250-43	0.0451	0.105	917	1,371	1,438	1,672 ¹	1,324	1,718	1,776	1,979 ¹	515	638	656	719 ¹	1,091	1,351	1,389	1,523 ¹
600PJ250-54	0.0566	0.105	1,397	2,055	2,152	2,492 ¹	2,087	2,662	2,747	3,044 ¹	872	1,064	1,092	1,191 ¹	1,869	2,279	2,339	2,551 ¹
600PJ250-68	0.0713	0.105	2,142	3,097	3,238	3,731 ¹	3,307	4,147	4,272	4,706 ¹	1,469	1,764	1,807	1,959 ¹	3,179	3,817	3,912	4,241 ¹
600PJ250-97	0.1017	0.105	4,134	5,818	6,067	6,936 ¹	6,690	8,184	8,406	9,177 ¹	3,204	3,764	3,847	4,136 ¹	7,026	8,254	8,436	9,069 ¹
600PJ250-118	0.1242	0.105	5,989	8,298	8,641	9,833 ¹	9,935	11,993	12,299	13,361 ¹	4,930	5,724	5,842	6,252 ¹	10,876	12,628	12,888	13,793 ¹
600PJ350-68	0.0713	0.105	2,142	3,097	3,238	3,731 ¹	3,307	4,147	4,272	4,706 ¹	1,469	1,764	1,807	1,959 ¹	3,179	3,817	3,912	4,241 ¹
600PJ350-97	0.1017	0.105	4,134	5,818	6,067	6,936 ¹	6,690	8,184	8,406	9,177 ¹	3,204	3,764	3,847	4,136 ¹	7,026	8,254	8,436	9,069 ¹
600PJ350-118	0.1242	0.105	5,989	8,298	8,641	9,833 ¹	9,935	11,993	12,299	13,361 ¹	4,930	5,724	5,842	6,252 ¹	10,876	12,628	12,888	13,793 ¹
800PJ250-43	0.0451	0.105	915	1,368	1,435	1,669	1,322	1,715	1,773	1,976	447	553	569	624	946	1,171	1,205	1,321
800PJ250-54	0.0566	0.105	1,395	2,051	2,149	2,487	2,084	2,658	2,743	3,039	777	948	973	1,061	1,666	2,031	2,085	2,273
800PJ250-68	0.0713	0.105	2,139	3,092	3,234	3,726	3,302	4,141	4,266	4,699	1,336	1,604	1,644	1,782	2,891	3,472	3,558	3,857
800PJ250-97	0.1017	0.105	4,129	5,810	6,060	6,927	6,682	8,174	8,396	9,166	2,981	3,502	3,579	3,848	6,537	7,679	7,848	8,437
800PJ250-118	0.1242	0.105	5,983	8,289	8,631	9,822	9,924	11,980	12,285	13,346	4,630	5,377	5,487	5,872	10,216	11,861	12,106	12,955
800PJ350-68	0.0713	0.105	2,139	3,092	3,234	3,726	3,302	4,141	4,266	4,699	1,336	1,604	1,644	1,782	2,891	3,472	3,558	3,857
800PJ350-97	0.1017	0.105	4,129	5,810	6,060	6,927	6,682	8,174	8,396	9,166	2,981	3,502	3,579	3,848	6,537	7,679	7,848	8,437
800PJ350-118	0.1242	0.105	5,983	8,289	8,631	9,822	9,924	11,980	12,285	13,346	4,630	5,377	5,487	5,872	10,216	11,861	12,106	12,955
1000PJ250-43	0.0451	0.105	914	1,366	1,433	1,667	1,320	1,712	1,770	1,972	387	479	493	540	819	1,014	1,043	1,144
1000PJ250-54	0.0566	0.105	1,393	2,048	2,145	2,484	2,081	2,654	2,739	3,035	694	846	869	947	1,487	1,813	1,862	2,030
1000PJ250-68	0.0713	0.105	2,136	3,088	3,230	3,721	3,298	4,136	4,260	4,693	1,219	1,464	1,501	1,627	2,639	3,169	3,248	3,521
1000PJ250-97	0.1017	0.105	4,125	5,804	6,053	6,920	6,675	8,165	8,387	9,156	2,786	3,272	3,345	3,596	6,109	7,176	7,334	7,884
1000PJ250-118	0.1242	0.105	5,977	8,281	8,623	9,812	9,914	11,968	12,273	13,333	4,369	5,073	5,177	5,540	9,638	11,191	11,421	12,223
1000PJ350-68	0.0713	0.105	2,136	3,088	3,230	3,721	3,298	4,136	4,260	4,693	1,219	1,464	1,501	1,627	2,639	3,169	3,248	3,521
1000PJ350-97	0.1017	0.105	4,125	5,804	6,053	6,920	6,675	8,165	8,387	9,156	2,786	3,272	3,345	3,596	6,109	7,176	7,334	7,884
1000PJ350-118	0.1242	0.105	5,977	8,281	8,623	9,812	9,914	11,968	12,273	13,333	4,369	5,073	5,177	5,540	9,638	11,191	11,421	12,223
1200PJ250-54	0.0566	0.105	1,391	2,046	2,143	2,481	2,078	2,651	2,735	3,031	619	755	775	845	1,327	1,617	1,660	1,811
1200PJ250-68	0.0713	0.105	2,134	3,085	3,226	3,717	3,294	4,131	4,255	4,687	1,115	1,338	1,372	1,487	2,412	2,897	2,969	3,219
1200PJ250-97	0.1017	0.105	4,121	5,798	6,047	6,913	6,668	8,158	8,378	9,147	2,610	3,066	3,134	3,369	5,723	6,723	6,871	7,387
1200PJ250-118	0.1242	0.105	5,971	8,274	8,615	9,804	9,906	11,958	12,262	13,321	4,133	4,799	4,898	5,242	9,119	10,588	10,806	11,564
1200PJ350-68	0.0713	0.105	2,134	3,085	3,226	3,717	3,294	4,131	4,255	4,687	1,115	1,338	1,372	1,487	2,412	2,897	2,969	3,219
1200PJ350-97	0.1017	0.105	4,121	5,798	6,047	6,913	6,668	8,158	8,378	9,147	2,610	3,066	3,134	3,369	5,723	6,723	6,871	7,387
1200PJ350-118	0.1242	0.105	5,971	8,274	8,615	9,804	9,906	11,958	12,262	13,321	4,133	4,799	4,898	5,242	9,119	10,588	10,806	11,564
1400PJ250-54	0.0566	0.105	1,389	2,043	2,140	2,478	2,076	2,647	2,732	3,027	550	671	689	751	1,179	1,438	1,476	1,609
1400PJ250-68	0.0713	0.105	2,131	3,081	3,222	3,713	3,291	4,127	4,251	4,682	1,018	1,223	1,253	1,359	2,204	2,647	2,713	2,941
1400PJ250-97	0.1017	0.105	4,117	5,793	6,042	6,907	6,662	8,150	8,371	9,139	2,449	2,877	2,940	3,161	5,370	6,308	6,447	6,931
1400PJ250-118	0.1242	0.105	5,967	8,267	8,608	9,796	9,898	11,948	12,252	13,310	3,918	4,549	4,642	4,968	8,643	10,035	10,242	10,960
1400PJ350-68	0.0713	0.105	2,131	3,081	3,222	3,713	3,291	4,127	4,251	4,682	1,018	1,223	1,253	1,359	2,204	2,647	2,713	2,941
1400PJ350-97	0.1017	0.105	4,117	5,793	6,042	6,907	6,662	8,150	8,371	9,139	2,449	2,877	2,940	3,161	5,370	6,308	6,447	6,931
1400PJ350-118	0.1242	0.105	5,967	8,267	8,608	9,796	9,898	11,948	12,252	13,310	3,918	4,549	4,642	4,968	8,643	10,035	10,242	10,960
1600PJ250-68	0.0713	0.105	2,129	3,078	3,219	3,709	3,287	4,123	4,247	4,678	929	1,116	1,143	1,240	2,011	2,415	2,475	2,683
1600PJ250-97	0.1017	0.105	4,114	5,788	6,037	6,901	6,657	8,143	8,364	9,131	2,299	2,701	2,760	2,968	5,042	5,922	6,053	6,507
1600PJ250-118	0.1242	0.105	5,962	8,261	8,602	9,788	9,890	11,939	12,243	13,300	3,717	4,316	4,405	4,714	8,201	9,522	9,718	10,400

¹ Bearing length to web height ratio, N/h, exceeds limit of 1.0.

² Bearing length to thickness ratio, N/t, exceeds limit of 210.

Joist Hangers



StiffClip® JH: The Steel Network's StiffClip® JH series represents an ideal method to resist vertical loads. StiffClip JH eliminates the need for joist web stiffener at clip connection. Guide holes are provided for quick and accurate fastener placement. StiffClip JH can be made to accommodate any stud size, but is stocked for use with 6", 8", 10" and 12" stud depths. For allowable load data, see TSN's *Light Steel Framing Connections Catalog*, or visit www.steelnetwork.com.

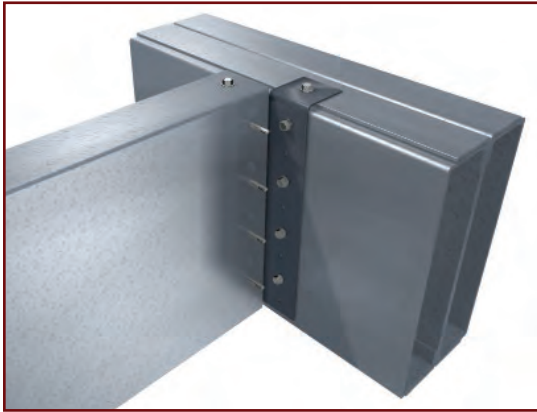

StiffClip® JC: The Steel Network's StiffClip® JC series connects floor joists to beams and other structural components while resisting vertical loads. Pre-drilled guide holes and a support flange streamline installation. StiffClip JC is available for use with 3 5/8", 6", 8", 10", 12" and 14" stud depths. For allowable load data, see TSN's *Light Steel Framing Connections Catalog*, or visit www.steelnetwork.com.

Bridging, Blocking & Web Stiffeners



BuckleBridge®: The Steel Network's BuckleBridge® series provides a solid bridging system to resist weak axis buckling and torsional rotation of members in floor systems. Elongated tabs in one end of BuckleBridge lock into a slot at the other end (through the stud knockout). Two vertical flaps at each end contain predrilled holes to facilitate the attachment to the stud in load bearing applications. BuckleBridge automatically spaces studs at 16" o.c. For allowable load data, see TSN's *Light Steel Framing Connections Catalog*, or visit www.steelnetwork.com.

Floor Systems

Double Joist End Bearing

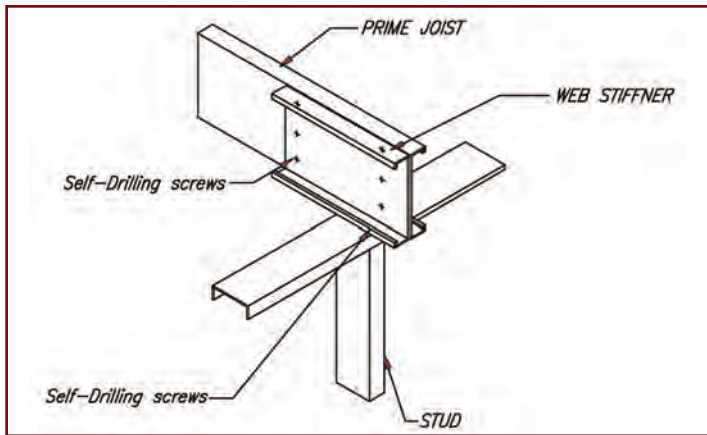

PrimeJoist® Example Details

Joist End Web Stiffener, Tight

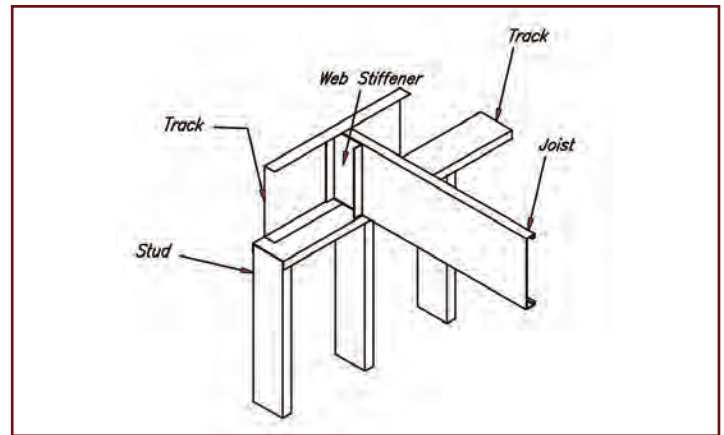

Floor Joist Bridging

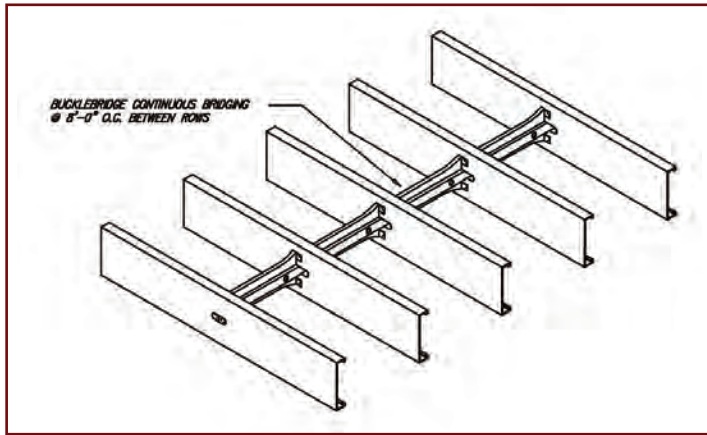

Ledger Framing

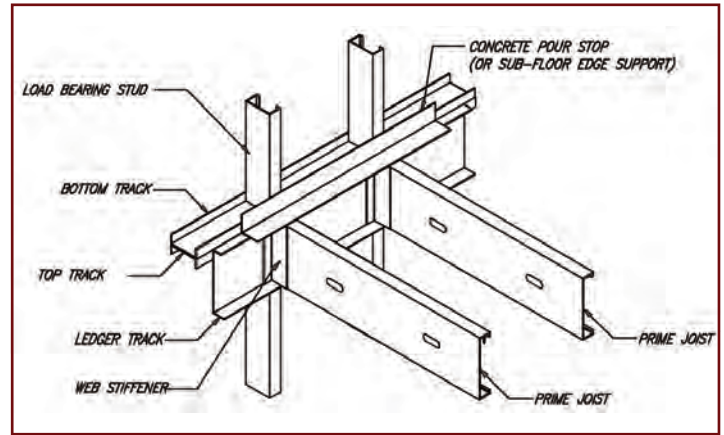

JH, Rigid, Steel Top Flange

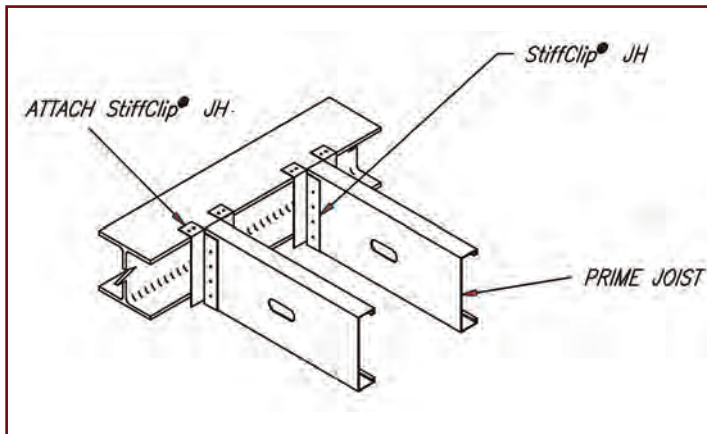

Joist Bearing on LSF Below

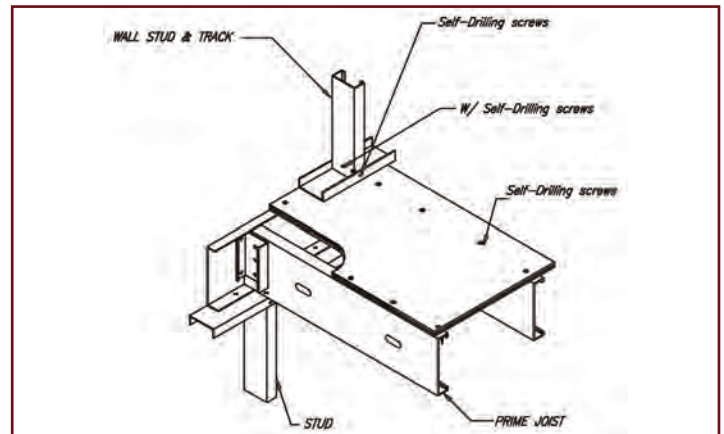

Stair Opening Perpendicular to Joist

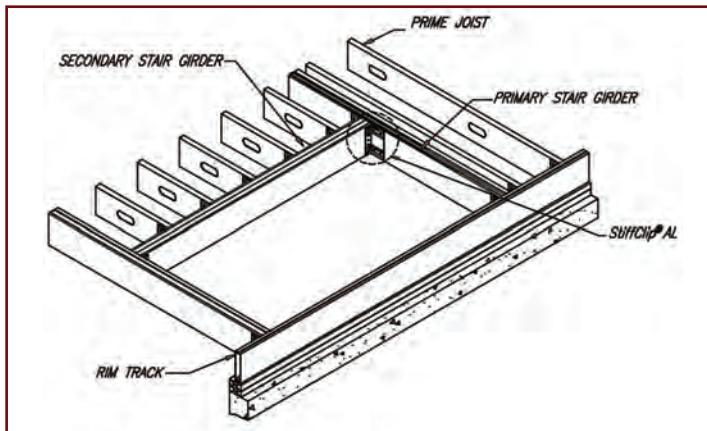

Stair Opening Parallel to Joist

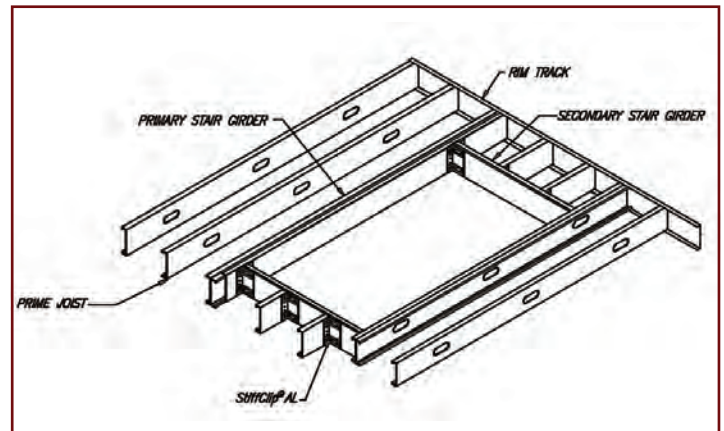

SteelSmart System 7.8

With 2018 IBC, AISI S100-16 & ASCE 7-16

The industry's #1 tool for the design of Members, Connections, Fasteners & Details Introduction:

SteelSmart® System (SSS) provides construction professionals with an essential tool engineered for both fast and accurate design. SSS 7.8 raises the bar for light steel framing analysis and design by seamlessly integrating the well-known analytic power of its predecessors with additional functionality and accessibility.

Available as a complete suite, SteelSmart System 7.8 will streamline production through the design and detailing of members, connections, and fasteners. Available design modules include: Curtain Wall, Load Bearing Wall, X-Brace Shear Wall, Floor Framing, Roof Framing, Roof Trusses, and Moment-Resisting Short Wall. SSS 7.8 incorporates two Advanced Features, the Load Generator and Distributor and the Layout and Connection Details Generator, that further aid the user in the design process.



Order online at www.steelSMARTsystem.com

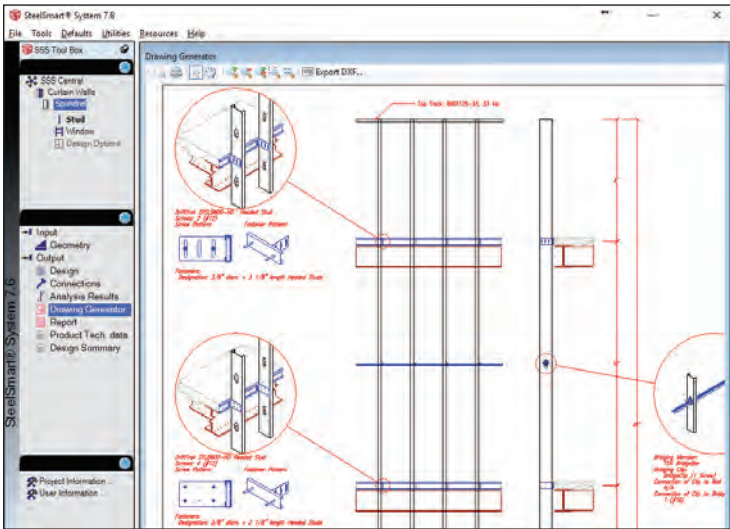

Layout and Connection Details Generator

A major feature of SSS is the Layout and Connection Details Generator. The framing layout of components is generated with connection details that include connection design data (clips designations, number of fasteners, embedment lengths, and screw patterns). The drawing generator is included within all 7 primary design modules, and will create a detail upon successful design of components. The drawings can be printed or exported in the AutoCAD® DXF format allowing the drawings to be easily transferred into other drafting software.

In addition to the Layout and Connection Details generator, there is also a library of component details within SSS. Details are split into 7 categories including: Curtain Wall, Load Bearing Walls, Shear Walls, Products Details, Floor Framing, Roof Framing, and LSF Systems.

Load Generator and Distributor

The Load Generator and Distributor tool uses the dimensions and load specification for a building to calculate the lateral wind and seismic forces according to ASCE 7 "Minimum Design Loads for Buildings and Other Structures." Now included in the Load Generator is the IBC 2018 and ASCE 7-16 design codes for development of lateral forces and snow loads. The output from the load generator gives the lateral forces distributed between floor levels and the shear walls at that floor level. The method of distribution considers either rigid or flexible floor diaphragms, while considering torsional effects when rigid diaphragms are selected. Output can be exported directly into the X-Brace Shear Wall design module or into an Excel spreadsheet.



Contact ASI for licensing information:
 Phone: (919) 645-4090
 Fax: (919) 645-4085
 Website: www.appliedscienceint.com
 Email: support@appliedscienceint.com

Product Use

Products in this catalog are designed and manufactured for the specific purposes shown, and should not be used in other applications unless approved by a qualified design professional. All modifications to products or changes in installation procedures should be made by a qualified design professional. The performance of such modified products or altered installation procedures is the sole responsibility of the design professional or installation contractor. The installation contractor and/or qualified design professional are responsible for installing all products in accordance with relevant specifications and building codes.

Customers modifying products or installation procedures, or designing non-standard products for fabrication by The Steel Network, Inc. ("TSN") shall, regardless of specific instructions to the user, indemnify, defend, and hold TSN harmless for any and all claimed loss or damage occasioned in whole or in part by non-standard or modified products or installation procedures.

Loads published on TSN's website and current product catalogs are for the described specific applications of properly installed products. Modifications to TSN products, improper loading or installation procedures, or deviations from recommended applications will affect TSN products' load-carrying capacities. TSN products are fabricated from hot-dipped galvanized steel for corrosion protection but will corrode and lose load-carrying capacity if exposed to salt air, corrosive fire-retardant chemicals, fertilizers, or other substances that may adversely affect steel or its galvanized coating. The current editions of TSN's catalogs and load tables published on this website may reflect changes in the allowable loads and configurations of some of TSN's products. This information supersedes information in earlier catalogs or technical reports. All earlier catalogs or technical reports should be discarded and reference made exclusively to the versions available at <http://www.steelnetwork.com/Site/Catalogs>. TSN may correct any clerical or typographical errors. All sales are subject to TSN's standard terms and conditions of sale.

Limited Warranty

TSN warrants its products to be free from defects in material or workmanship at the time of shipment. TSN standard catalog products are warranted for adequacy of design when used in accordance with design limits in this catalog and properly specified and installed. TSN products shall not be substituted with non-TSN products if it is part of a system. Substitution of a TSN product will immediately void any warranty claim made by Purchaser. This warranty excludes uses not in compliance with specific applications and installation procedures set forth in this catalog. Warranty claims must be made by Purchaser in writing within ninety (90) days of receipt of the products.

All warranty obligations of TSN shall be limited, at the sole discretion of TSN, to repair or replace the defective product(s). These remedies shall constitute TSN's sole obligation and sole remedy of purchaser under this warranty. In no event will TSN be responsible for incidental, consequential, indirect, exemplary, special, or punitive damages, or other losses or damages however caused, including, but not limited to, installation costs, lost revenue or lost profits. TSN's liability for damages shall in no event exceed the applicable portion of the purchase price for defective product(s).

Product defects that arise from acts of God, accidents, misuse, misapplication, improper installation, storage damage, negligence, or modification to product(s) or its components are specifically excluded from this warranty. Product defects that arise from Purchaser providing incorrect information to TSN, including but not limited to incorrect specifications such as incorrect dimensions, designs and/or loads, are also specifically excluded from this warranty. TSN does not authorize any person or party to assume or create for it any other obligation or liability in connection with Products except as set forth herein.

This Warranty is expressly in lieu of all other warranties, expressed or implied, including any warranties of merchantability or fitness for a particular purpose, all such other warranties being hereby expressly excluded.

Patented Technology

BackIt®, BridgeBar®, BridgeClip®, BuckleBridge®, CircleTrak®, DriftClip®, DriftCorner®, DriftTrak®, GripClip®, 600JAM®, 800JAM®, JamStud®, MidWall™, MasterClip®, NotchTrak®, PrimeWall®, 600SG®, 800SG®, SigmaStud®, SigmaTrak®, Step-Bushing Technology™, StiffClip®, StiffWall®, ThermaFast®, TightStrap®, VertiClip®, and VertiTrack® are trademarked products, and are patented or patent-pending technologies of TSN. Numerous TSN design configurations are patented and/or patent pending and are protected under US and International patent laws. Patent numbers include: #4,970,410; #4,970,411; #4,970,412; #4,970,413; #5,079,710; #5,467,566; #5,904,023; #5,906,080; #6,612,087; #6,701,689; #6,892,504; #7,104,024; #7,503,150; #7,559,519; #7,596,921; #7,634,889; #7,788,878; #7,832,162; #7,836,657; #8,132,383; #8,181,419; #8,205,402; #8,387,321 and #8,683,770.

Contact Information

North Carolina
(Headquarters)
2012-A TW Alexander Blvd
P.O. Box 13887
Durham, NC 27709
Phone: (919) 845-1025
Fax: (888) 474-4877

Texas
600 Lemens Avenue
Suite 120
Hutto, TX 78634
Phone: (512) 642-9603
Fax: (512) 857-1663

Nevada
1650 Helm Drive
Suite 1000 - 1200
Las Vegas, NV 89119
Phone: (702) 643-4330
Fax: (702) 643-4331

Web Site: www.steelnetwork.com
E-mail: support@steelnetwork.com

Toll Free Nationwide Phone
(888) 474-4876



