

TightStrap® - Flat Strap Tensioning Tool User Guide

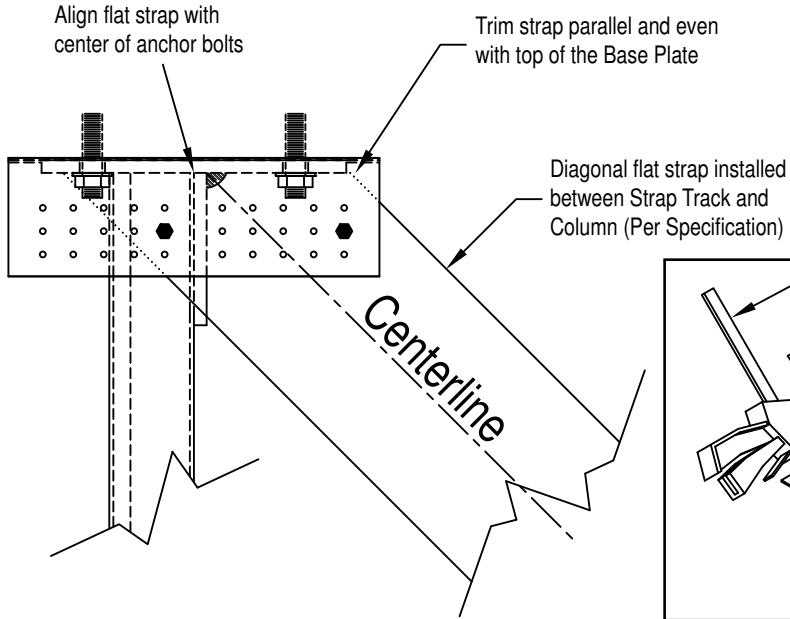

1. Align and trim flat strap at each corner, attach one end with at least two screws.



2. Align Track Connector and attach to track.

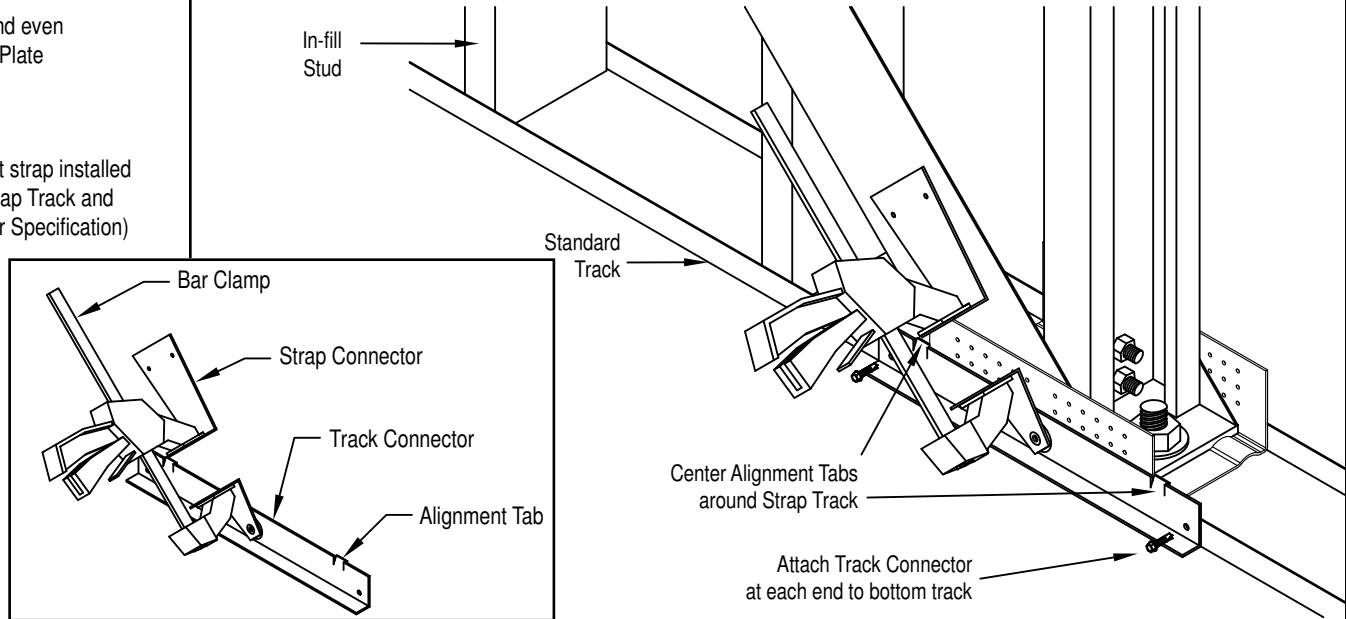

3. Extend Bar Clamp, align Strap Connector with centerline of flat strap and attach Strap Connector to the flat strap.

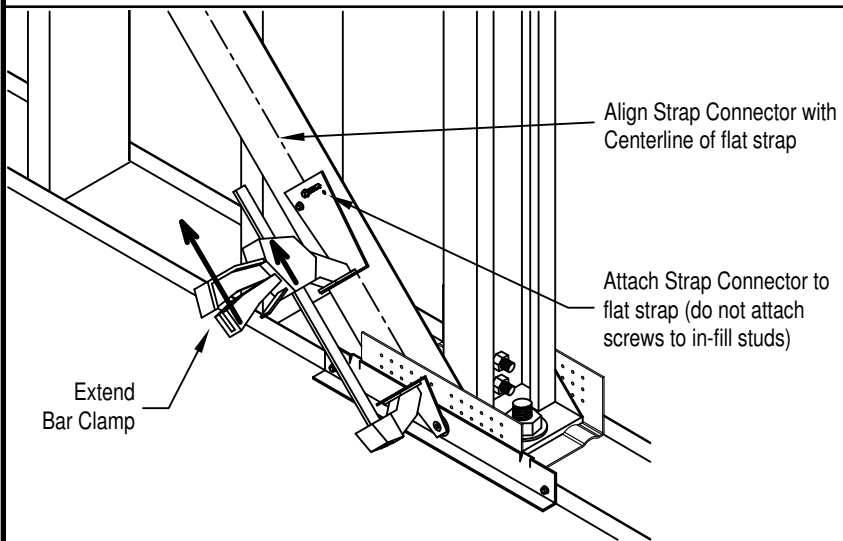

4. Engage Bar Clamp, install at least two screws for flat strap attachment, remove TightStrap® tensioning tool and install remaining screws for strap attachment.

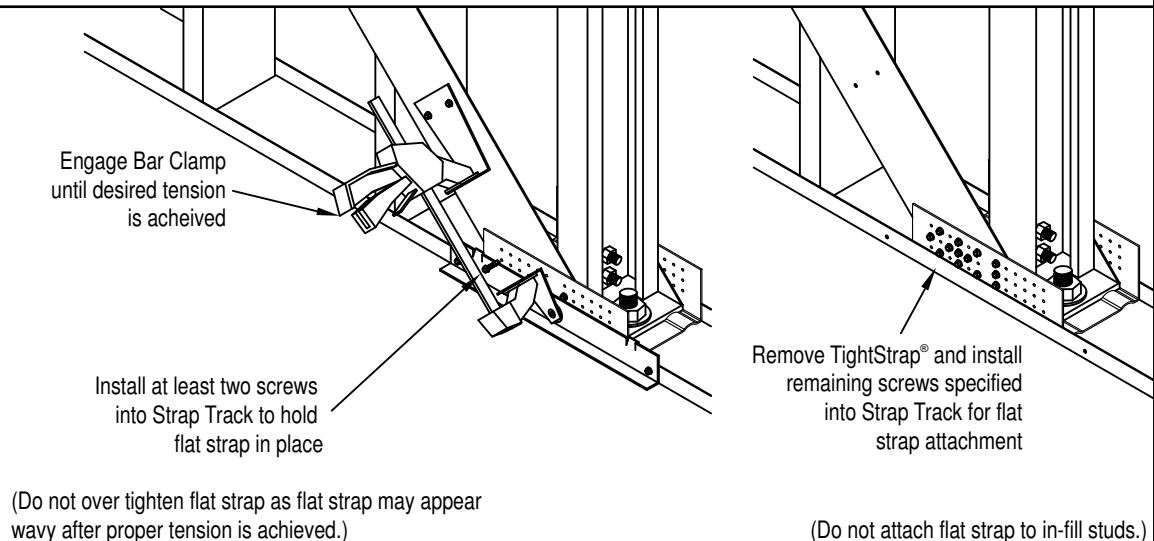

(Do not over tighten flat strap as flat strap may appear wavy after proper tension is achieved.)

(Do not attach flat strap to in-fill studs.)