

Design/System/Construction/Assembly Usage Disclaimer

- Authorities Having Jurisdiction should be consulted in all cases as to the particular requirements covering the installation and use of UL Certified products, equipment, system, devices, and materials.
- Authorities Having Jurisdiction should be consulted before construction.
- Fire resistance assemblies and products are developed by the design submitter and have been investigated by UL for compliance with applicable requirements. The published information cannot always address every construction nuance encountered in the field.
- When field issues arise, it is recommended the first contact for assistance be the technical service staff provided by the product manufacturer noted for the design. Users of fire resistance assemblies are advised to consult the general Guide Information for each product category and each group of assemblies. The Guide Information includes specifics concerning alternate materials and alternate methods of construction.
- Only products which bear UL's Mark are considered Certified.

BXUV - Fire Resistance Ratings - ANSI/UL 263 Certified for United States

BXUV7 - Fire Resistance Ratings - CAN/ULC-S101 Certified for Canada

See General Information for Fire-resistance Ratings - ANSI/UL 263 Certified for United States Design Criteria and Allowable Variances

See General Information for Fire Resistance Ratings - CAN/ULC-S101 Certified for Canada Design Criteria and Allowable Variances

Design No. V450

February 8, 2024

Nonbearing Wall Rating — 1, 2 or 2-1/2 Hr (See Items 1, 2, 3 through 3G, 3K)

*** Indicates such products shall bear the UL or cUL Certification Mark for jurisdictions employing the UL or cUL Certification (such as Canada), respectively.**

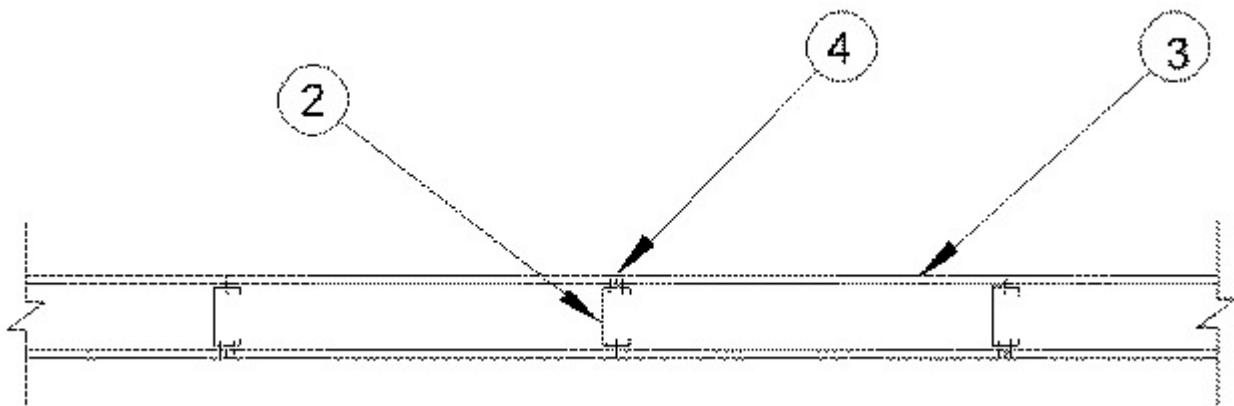

1. Framing Members* — Floor and Ceiling Runners — (Not Shown) — For a 1 hour rating, use with Items 3, through 3K only, proprietary channel shaped, min. 3-5/8 in. wide, fabricated from min. 0.0150 in. (min bare metal thickness) galvanized steel, attached to floor and ceiling with fasteners 24 in. OC max. For a 2 hour rating, use with Items 3A through 3F, proprietary channel shaped, min.

1-5/8 in. wide, fabricated from min. 0.0150 in. (min bare metal thickness) galvanized steel, attached to floor and ceiling with fasteners 24 in. OC max. For a 2-1/2 hour rating, use with Item 3F, proprietary channel shaped, min. 2-1/2 in. wide, fabricated from min. 0.0150 in. (min bare metal thickness) galvanized steel, attached to floor and ceiling with fasteners 24 in. OC max. Gypsum board may be applied vertically or horizontally as described in Items 3 through 3F.

CLARKDIETRICH BUILDING SYSTEMS — CD ProTRAK

DMFCWBS L L C — ProTRAK™

MBA METAL FRAMING — ProTRAK

RAM SALES L L C — Ram ProTRAK

STEEL STRUCTURAL PRODUCTS L L C — Tri-S ProTRAK

2. **Framing Members*** — **Steel Studs** — For a 1 hour rating, use with Items 3 through 3K only, proprietary channel shaped studs, min. 3-5/8 in. wide, fabricated from min. 0.0150 in. (min bare metal thickness) galvanized steel, spaced a max of 24 in. OC. For a 2-1/2 hour rating, use with Item 3F only, proprietary channel shaped studs, min. 2-1/2 in. wide, fabricated from min. 0.0150 in. (min bare metal thickness) galvanized steel, spaced a max of 24 in. OC. Studs to be cut 3/4 in. less than assembly height. For a 2 hour rating, use with Items 3A through 3I only, proprietary channel shaped studs, min. 1-5/8 in. wide, fabricated from min. 0.0150 in. (min bare metal thickness) galvanized steel, spaced a max of 24 in. OC. Studs to be cut 3/4 in. less than assembly height. Gypsum boards may be applied vertically or horizontally as described in Items 3 through 3I.

CLARKDIETRICH BUILDING SYSTEMS — CD ProSTUD

DMFCWBS L L C — ProSTUD™

MBA METAL FRAMING — ProSTUD

RAM SALES L L C — Ram ProSTUD

STEEL STRUCTURAL PRODUCTS L L C — Tri-S ProSTUD

3. **Gypsum Board*** — For 1 Hour rating, one layer of 5/8 in. thick gypsum board applied vertically to studs with #6 x 1-1/4 in. long bugle head screws spaced 8 in. OC at the perimeter and 12 in. OC in the field of the boards. Vertical joints are staggered from vertical joints on opposite sides of the wall.

UNITED STATES GYPSUM CO — Type C

USG BORAL DRYWALL SFZ LLC — Type C

3A. **Gypsum Board*** — (As an alternate to Item 3) — For 1 Hour Rating, one layer of 5/8 in. thick gypsum board applied vertically to studs with #6 x 1 in. long bugle head screws spaced 8 in. OC at the perimeter and in the field of the boards. Vertical joints are staggered from vertical joints on opposite sides of the wall. For 1 Hour Rating, one layer of 5/8 in. thick gypsum board applied horizontally to studs with #6 x 1 in. long bugle head screws spaced 8-1/2 in. OC at the perimeter and in the field of the boards with the last two screws installed 1 and 2-1/2 in. from the edges of the boards. Vertical butt joints are staggered from vertical butt joints on opposite sides of the wall. Horizontal joints need not to be staggered on opposite sides of the wall or backed by steel framing. For 2 Hour Rating (Not Shown), two layers of 5/8 in. thick gypsum board applied horizontally. Base layer of board attached to studs with #6 x 1 in. long bugle head screws spaced 16 in. OC. starting 8 in. from the edge of the board with one screw 1-1/4 in. from the edge. Face layer of board attached to studs with #6 x 1-5/8 in. long bugle head screws spaced 16 in. OC. Starting 8 in. from the edge of the board with one screw 1-1/4 in. from the edge. Horizontal joints on the face layer are staggered 12 in. from the base layer. Horizontal joints need not to be backed by steel framing.

UNITED STATES GYPSUM CO — Type SCX

USG BORAL DRYWALL SFZ LLC — Type SCX

3B. Gypsum Board* — (As an alternate to Item 3) — For 1 hr rating (Vertical application) — One layer of 5/8 in. thick gypsum board applied vertically to studs with #6 x 1-1/4 in. long bugle head screws spaced 8 in. OC at the perimeter and 12 in. OC in the field of the boards. Vertical joints are centered over studs and staggered from vertical joints on opposite sides of the wall. For 2 hr rating (Vertical application - Not shown) - Two layers of 5/8 in. thick gypsum board applied vertically. Inner layer attached to studs with #6 x 1 in. long bugle head screws spaced 12 in. OC along the top and bottom tracks and 16 in. OC in the field and along the vertical edges. Outer layer attached to studs with #6 x 1-5/8 in. long bugle head screws spaced 12 in. OC along the top and bottom tracks and 16 in. OC in the field and along the vertical edges with screws offset 8 in. from inner layer. Vertical joints are centered over studs and staggered between layers and on opposite sides of the wall. For 2 hr rating (Horizontal application) - Two layers of 5/8 in. thick gypsum board applied horizontally. Inner layer attached to studs with #6 x 1 in. long Type S bugle head screws spaced 24 in. OC with the 1st screw installed 1-1/4 in. from the board edge and to the track only spaced 24 in. OC. Outer layer attached to studs with 1-5/8 in. long Type S bugle head screws spaced 16 in. OC with the 1st and 2nd screws installed 1-1/4 in. and 8 in. from the board edge, respectively; and to the track only spaced 16 in. OC. Horizontal joints on the face layer are staggered 12 in. from the base layer. Horizontal joints need not to be backed by steel framing.

NATIONAL GYPSUM CO — Types eXP-C, FSK, FSK-C, FSL, FSMR-C, FSW, FSW-3, FSW-6, FSW-8, FSW-C

3C. Gypsum Board* — (As an alternate to Item 3) — For 1 hr rating (Vertical application) — One layer of 5/8 in. thick gypsum board applied vertically to studs with #6 x 1-1/4 in. long bugle head screws spaced 8 in. OC at the perimeter and 12 in. OC in the field of the boards. Vertical joints are centered over studs and staggered from vertical joints on opposite sides of the wall. For 1 hr rating (Horizontal application) - One layer of 5/8 in. thick gypsum board attached horizontally to studs with 1 in. long Type S bugle head screws spaced 8 in. OC.; and to floor and ceiling runners with 1 in. long Type S bugle head screws spaced 8 in. OC. with the 1st screw 2 in. from board edge Horizontal joints need not be staggered on opposite faces or backed by steel framing. For 2 hr rating (Not Shown) - Two layers of 5/8 in. thick gypsum board applied vertically or horizontally. Inner layer attached to studs with #6 x 1 in. long bugle head screws spaced 12 in. OC along the top and bottom tracks and 16 in. OC in the field and along the vertical edges. Outer layer attached to studs with #6 x 1-5/8 in. long bugle head screws spaced 12 in. OC along the top and bottom tracks and 16 in. OC in the field and along the vertical edges. Vertical joints are centered over studs and staggered between layers and on opposite sides of the wall. Horizontal joints on the face layer are staggered 12 in. from the base layer. Horizontal joints need not to be backed by steel framing.

CERTAINTED GYPSUM INC — Types LGFC2A, LGFC6A, LGFC-C/A, LGFC-WD

3D. Gypsum Board* — (As an alternate to Item 3) — For 1 hr rating (Vertical application) — One layer of 5/8 in. thick gypsum board applied vertically to studs with #6 x 1 in. long bugle head screws spaced 8 in. OC at the perimeter and 12 in. OC in the field of the boards. Vertical joints are centered over studs and staggered from vertical joints on opposite sides of the wall. For 2 hr rating (Vertical application - Not Shown) - Two layers of 5/8 in. thick gypsum board applied vertically. Inner layer attached to studs with #6 x 1 in. long bugle head screws spaced 24 in. OC along the top and bottom tracks and 24 in. OC in the field and along the vertical edges. Outer layer attached to studs with #6 x 1-5/8 in. long bugle head screws spaced 16 in. OC along the top and bottom tracks and 16 in. OC in the field and along the vertical edges. Vertical joints are centered over studs and staggered between layers and on opposite sides of the wall.

GEORGIA-PACIFIC GYPSUM L L C — Type LW2X, Veneer Plaster Base - Type LW2X, Water Rated - Type LW2X, Sheathing - Type LW2X, Soffit - Type LW2X, Type DGL2W, Water Rated - Type DGL2W, Sheathing - Type DGL2W

3E. Gypsum Board* — (As an alternate to 5/8 in. Type FSW in Item 3B) — Nom. 5/16 in. thick gypsum panels applied vertically or horizontally. Two layers of 5/16 in. for every single layer of 5/8 in. gypsum board described in Item 3B. Horizontal joints on the same side need not be staggered. Inner layer of each double 5/16 in. layer attached with fasteners, as described in item 3B, spaced 24 in. OC. Outer layer of each double 5/16 in. layer attached per Item 3B.

NATIONAL GYPSUM CO — Type FSW

3F. Gypsum Board* — (As an alternate to Item 3) — For 1 Hour Rating — One layer of 5/8 in. thick, 4 ft. wide, gypsum board applied vertically to studs with #6 x 1 in. long bugle head screws spaced 8 in. OC at the perimeter, starting 4 in. from the edge of the boards, and 12 in. OC in the field of the boards, starting 6 in. from the edge of the board. Vertical joints are staggered from vertical joints on opposite sides of the wall. For 2 or 2-1/2 Hour Rating - (Not Shown) - Two layers of 5/8 in. thick, 4 ft. wide, gypsum board applied vertically. Inner layer attached with #6 x 1 in. long bugle head screws spaced 12 in. OC along the top and bottom tracks with one screw located 6 in. from each edge of the board and 16 in. OC along the studs with one screw located 8 in. from one edge of the board. Outer layer attached with #6 x 1-5/8 in. long bugle head screws spaced 12 in. OC along the top and bottom tracks with one screw located 1-1/2 in. from each edge of the board and 16 in. OC along the studs with one screw located 8 in. from one edge of the

board as to offset the face layer screws 8 in. from the base layer screws. Vertical joints are centered over studs and staggered between layers and on opposite sides of the wall.

AMERICAN GYPSUM CO — Types AGX-1, M-Glass, LightRoc

3G. Gypsum Board* — (As an alternate to Item 3) — For 1 Hour Rating — One layer of 5/8 in. thick, 4 ft. wide, gypsum panels with beveled, square or tapered edges. Gypsum panels applied vertically or horizontally with joints centered over studs. Horizontal joints need not be backed by steel framing. Horizontal edge joints and horizontal butt joints on opposite sides of studs need not be staggered. When applied horizontally, gypsum panels fastened to framing with 1 in. long Type S or S-12 steel screws 1-1/2 in. from board edges, 3 in. from board edge, every 8 in. OC in the field, and 12 in. along the top and bottom edges of the wall. When applied vertically, gypsum panels fastened to framing with 1 in. long Type S or S-12 steel screws every 8 in. OC in the field and 12 in. along the top and bottom edges of the wall. For 2 hr rating - (Not Shown) - Two layers of 5/8 in thick, 4ft wide, gypsum board applied vertically or horizontally Vertical joints centered over studs and staggered one stud cavity on opposite sides of studs. Vertical joints to be staggered between layers and on opposite side of wall. Horizontal joints need not be backed by steel framing. Horizontal edge joints and horizontal butt joints on opposite sides of studs need not be staggered. Horizontal edge joints and horizontal butt joints between layers to be staggered a min of 12 in. For vertical application of gypsum board, base layer to be fastened with 1 in. screws spaced 12 in. OC and face layer to be fastened with 1-5/8 in. screws spaced 12 in. OC. For horizontal application of gypsum board, base layer to be fastened with screws spaced 16 in. OC and face layer to be fastened with 1-5/8 screws spaced 16 in. OC. In either vertical or horizontal applications, Type S or Type S-12 steel screws are to be used.

CERTAINTED GYPSUM INC — Type X-1, Easi-Lite Type X-2, GlasRoc, Type Silent FX

3H. Gypsum Board* — (As an alternate to Items 3 through 3G) — Nominal 5/8 in. thick, 4 ft wide panels, applied vertically only and fastened to the studs and plates with 1 in. long, Type S steel screws spaced, 12 in. OC.

NATIONAL GYPSUM CO — Type SBWB

3I. Gypsum Board* — (As an alternate to Items 3-3H) — Required to be used with Item 5) — For 1 Hour Rating — One layer of 5/8 in. thick, 4 ft. wide, gypsum panels with beveled, square or tapered edges. Gypsum panels applied vertically or horizontally with joints centered over studs. Horizontal joints need not be backed by steel framing. Horizontal edge joints and horizontal butt joints on opposite sides of studs need not be staggered. When applied horizontally, gypsum panels fastened to framing with 1 in. long Type S or S-12 steel screws 1-1/2 in. from board edges, 3 in. from board edge, and every 8 in. OC in the field, and 12 in. along the top and bottom edges of the wall. When applied vertically, gypsum panels fastened to framing with 1 in. long Type S or S-12 steel screws every 8 in. OC in the field and 12 in. along the top and bottom edges of the wall. For 2 hr rating - (Not Shown) - Two layers of 5/8 in thick, 4ft wide, gypsum board applied vertically or horizontally Vertical joints centered over studs and staggered one stud cavity on opposite sides of studs. Vertical joints to be staggered between layers and on opposite side of wall. Horizontal joints need not be backed by steel framing. Horizontal edge joints and horizontal butt joints on opposite sides of studs need not be staggered. Horizontal edge joints and horizontal butt joints between layers to be staggered a min of 12 in. For vertical application of gypsum board, base layer to be fastened with 1 in. screws spaced 12 in. OC and face layer to be fastened with 1-5/8 in. screws spaced 12 in. OC. For horizontal application of gypsum board, base layer to be fastened with screws spaced 16 in. OC and face layer to be fastened with 1-5/8 screws spaced 16 in. OC. In either vertical or horizontal applications, Type S or Type S-12 steel screws are to be used.

CERTAINTED GYPSUM INC — 5/8 in. Easi-Lite Type X

3J. Gypsum Board* — (As an alternate to Item 3) — For 1 hr rating (Vertical application) — One layer of 5/8 in. thick gypsum board applied vertically to studs with #6 x 1 in. long bugle head screws spaced 8 in. OC at the perimeter and 12 in. OC in the field of the boards. Vertical joints are centered over studs and staggered from vertical joints on opposite sides of the wall. For 2 hr rating (Vertical application - Not shown) - Two layers of 5/8 in. thick gypsum board applied vertically. Inner layer attached to studs with #6 x 1 in. long bugle head screws spaced 24 in. OC along the top and bottom tracks and 24 in. OC in the field and along the vertical edges. Outer layer attached to studs with #6 x 1-5/8 in. long bugle head screws spaced 16 in. OC along the top and bottom tracks and 16 in. OC in the field and along the vertical edges. Vertical joints are centered over studs and staggered between layers and on opposite sides of the wall.

CERTAINTED GYPSUM INC — Type C

3K. Gypsum Board* — (As an alternate to Item 3) — For 1 Hour Rating — One layer of 5/8 in. thick, 4 ft. wide, gypsum panels with beveled, square or tapered edges. Gypsum panels applied vertically or horizontally with joints centered over studs. Horizontal joints need not be backed by steel framing. Horizontal edge joints and horizontal butt joints on opposite sides of studs need not be staggered. Gypsum panels fastened to framing with 1 in. long Type S or S-12 steel screws every 12 in. OC in the field and perimeter when applied vertically or horizontally. For 2 hr rating - (Not Shown) - Two layers of 5/8 in thick, 4ft wide, gypsum board applied vertically or horizontally Vertical joints centered over studs and staggered one stud cavity on opposite sides of studs. Vertical joints to

be staggered between layers and on opposite side of wall. Horizontal joints need not be backed by steel framing. Horizontal edge joints and horizontal butt joints on opposite sides of studs need not be staggered. Horizontal edge joints and horizontal butt joints between layers to be staggered a min of 12 in. For vertical application of gypsum board, base layer to be fastened with 1 in. screws spaced 12 in. OC and face layer to be fastened with 1-5/8 in. screws spaced 12 in. OC. For horizontal application of gypsum board, base layer to be fastened with screws spaced 16 in. OC and face layer to be fastened with 1-5/8 in. screws spaced 16 in. OC. In either vertical or horizontal applications, Type S or Type S-12 steel screws are to be used.

CGC INC — Type ULIX

UNITED STATES GYPSUM CO — Type ULIX

3L. **Gypsum Board*** — As an alternate to Item 3 (For 1 hr rating) — Nom. 5/8 in. thick gypsum panels applied vertically or horizontally. Horizontal edge joints and horizontal butt joints on opposite sides of studs need not be staggered or backed by steel framing. Gypsum panels fastened to framing with 1 in. long Type S steel screws 12 in. OC along vertical edges and in the field. Screws spaced a max 12 in. along the top and bottom edges of the wall for both vertical and horizontal applications.

NATIONAL GYPSUM CO — Types eXP-C, FSK, FSK-C, FSK-G, FSL, FSW-C, FSW-G, FSW, FSW-3, FSW-5, FSW-6, FSMR-C

3M. **Gypsum Board*** — (As an alternate to Item 3) — For 1 Hour Rating (Required to be used with Item 5) — One layer of 5/8 in. thick, 4 ft. wide, gypsum panels with beveled, square or tapered edges. Gypsum panels applied vertically or horizontally with joints centered over studs. Horizontal joints need not be backed by steel framing. Horizontal edge joints and horizontal butt joints on opposite sides of studs need not be staggered. Gypsum panels fastened to framing with 1 in. long Type S or S-12 steel screws spaced 8 in. OC in the field and 12 in. OC along the top and bottom edges of the wall. For 2 Hour Rating, Nom. 5/8 in. thick gypsum panels applied vertically or horizontally. Vertical joints centered over studs and staggered one stud cavity on opposite sides of studs. Vertical joints in adjacent layers staggered one stud cavity. Horizontal edge joints and horizontal butt joints on opposite sides of studs need not be staggered or backed by steel framing. Horizontal edge joints and horizontal butt joints in adjacent layers need not be staggered. Base layer panels fastened to framing with 1 in. Type S or S-12 steel screws spaced 16 in. OC. Face layer fastened to framing with 1-5/8 in. Type S or S-12 steel screws spaced 16 in. OC, starting with an 8 in. stagger at the joint. Additional terminating screw at face layer joint located approximately 1 in. from horizontal joints.

CERTAINTED GYPSUM INC — Types CLLX

3N. **Gypsum Board*** — (As an alternate to Item 3, for 1 hr. rating) — Nom. 5/8 in. thick gypsum panels applied vertically or horizontally. Horizontal edge joints and horizontal butt joints on opposite sides of studs need not be staggered or backed by steel framing. Gypsum panels fastened to framing with 1 in. long Type S steel screws 12 in. OC along vertical edges and in the field. Screws spaced a max 12 in. along the top and bottom edges of the wall for both vertical and horizontal applications.

CERTAINTED GYPSUM INC — Type X-1, SilentFX, GlasRoc, Type C

4. **Joint Tape and Compound** — Vinyl or casein, dry or premixed joint compound applied in two coats to outer layer joints and screw heads. Paper tape, nom 2 in. wide, embedded in first layer of compound over all joints.

5. **Batts and Blankets*** — (Optional, Not Shown) — Friction fit in stud cavities, any glass fiber or mineral wool insulation bearing the UL Classification Marking as to Fire Resistance.

See **Batts and Blankets** (BZJZ) for names of Classified companies.

6. **Framing Members* — Resilient Channels** — (Optional, Not Shown) — Resilient furring channels fabricated from min. 25 MSG corrosion-protected steel, spaced vertically a max of 24 in. OC. flange portion attached to each intersecting stud with 1/2 in. long Type S-12 panhead steel screws.

CLARKDIETRICH BUILDING SYSTEMS — Type RCSD, RCUR

7. **Barrier Mesh** — (Optional, Not Shown) - Attached to steel studs on one or both sides of the wall using Barrier Mesh Clips spaced at maximum 12 inches on center vertically, using a flat head type screw penetrating through the steel at least 3/8 of an inch. For Steel Studs less than 0.033 inches in thickness, use self-piercing screws. For Steel Studs equal to or greater than 0.033 inches in thickness, use steel drill screws (self-tapping). Gypsum Board (Item 3) to be installed directly over the Barrier Mesh using prescribed screw patterns with lengths increased by a minimum 1/8 in. Barrier Mesh may be installed with the long dimension of the diamond pattern positioned vertically or horizontally. Barrier Mesh joints may occur as butt joints at the framing members and secured using the Barrier

Mesh Clips or occur in between framing members as overlapping joints secured using 18 SWG wire ties spaced a maximum 12 in. on center.

CLARKDIETRICH BUILDING SYSTEMS — Barrier Mesh, Barrier Mesh Clips

*** Indicates such products shall bear the UL or cUL Certification Mark for jurisdictions employing the UL or cUL Certification (such as Canada), respectively.**

Last Updated on 2024-02-08

The appearance of a company's name or product in this database does not in itself assure that products so identified have been manufactured under UL Solutions' Follow - Up Service. Only those products bearing the UL Mark should be considered to be Certified and covered under UL Solutions' Follow - Up Service. Always look for the Mark on the product.

UL Solutions permits the reproduction of the material contained in Product iQ subject to the following conditions: 1. The Guide Information, Assemblies, Constructions, Designs, Systems, and/or Certifications (files) must be presented in their entirety and in a non-misleading manner, without any manipulation of the data (or drawings). 2. The statement "Reprinted from Product iQ with permission from UL Solutions" must appear adjacent to the extracted material. In addition, the reprinted material must include a copyright notice in the following format: "©2024 UL LLC."