

USG  
Ceiling  
Solutions

## USG CEILINGS PLUS® BARZ®

ULTRA LIGHTWEIGHT  
LINEAR BAFFLES

INSTALLATION GUIDE



CEILINGS PLUS®

Architect: Gensler  
Photo: © Jasper Sanidad

# Introduction

Enter **BARZ**<sup>®</sup> - Innovative ceiling designs brought to you by **USG Ceilings Plus**. In this manual we'll show you how to perform the installation the right way, the first time. Go ahead, install with a smile..

The purpose of this installation manual is to provide you with general steps and procedures on how to properly and safely install **BARZ**<sup>®</sup> ceiling systems as well as how to address various field conditions.

Please read this entire manual and familiarize yourself with all procedures before you begin. If you have been supplied with project drawings specific to your order, make sure you have a thorough understanding of those. Any details within those documents will supersede this manual. Work area must be clear of debris and obstacles to ensure a safe and fast installation.

**Please work safely!**

# Table of Contents

<b>Preparation</b>	
Component Identification	1
Tools	2
<b>Module Planning</b>	
Layout Options	3
Layout Options	4
<b>Grid Planning</b>	
Blank Grid	5
<b>General Installation</b>	
Install Hanger Wire & Main Tees	6
Install Cross Tees	7
Level Grid System	8
Install Cassettes Into Grid	9
Fully Installed System	10
Floating Edge - Grid Concealment	11 - 12
Field Cutting	13
Field Cutting (2" x 6" Cassette)	14 - 16
Field Cutting (2" x 8" Cassette)	17- 20
Installing End-Caps	21
<b>Perimeter Conditions</b>	
Straight Wall Condition	22
Angled Wall Condition	23
Column Integration	24
<b>MEP Integration</b>	
Lighting	25
Sprinklers	26
HVAC	27
<b>Custom Installations</b>	
General Wall Installation	28 - 30
Custom Cassette - Wall Installation	31 - 33
<b>Maintenance</b>	
Adjust & Clean	34
<b>Support</b>	
Contacts	34
<b>Notices</b>	
	35
<b>Notes</b>	
	36



# Preparation

## Component Identification

### Typical Supplied Components

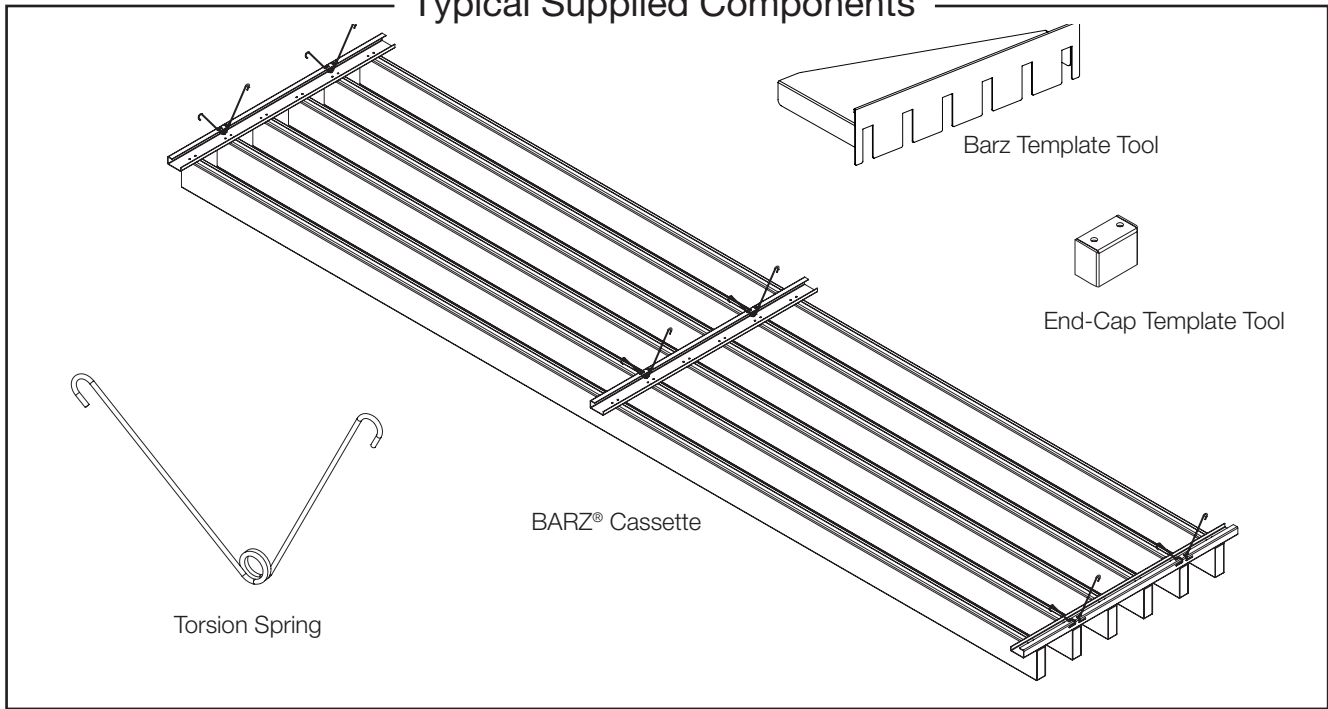

### Available Accessories

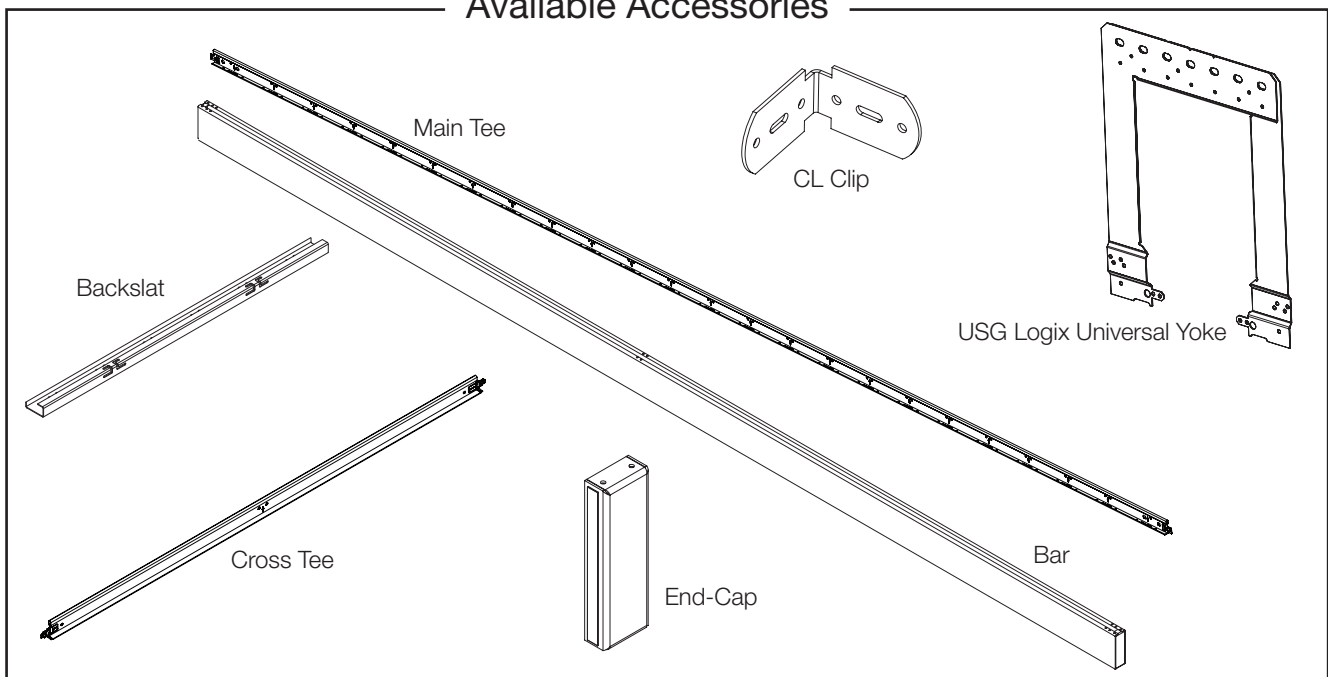



# Preparation Tools

## Standard Tools



Safety Goggles



Hard Hat

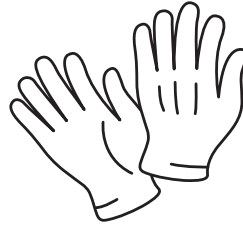

White Cotton Gloves

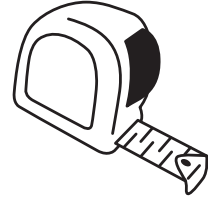

Tape Measure



Square



Lineman Wire Cutters

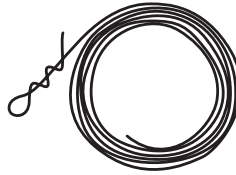

Hanger Wire

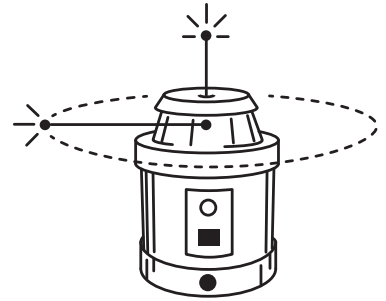

Laser Level

## Field Modification Tools

Left



Right



Center



Snips Set

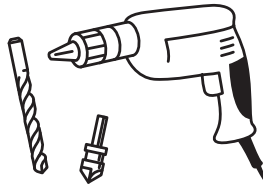

Drill with 1/8" Diameter Standard & Counter-Sink Bits

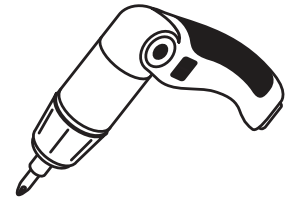

Electric Screwdriver

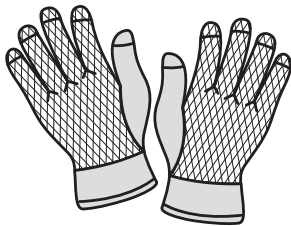

Working Gloves

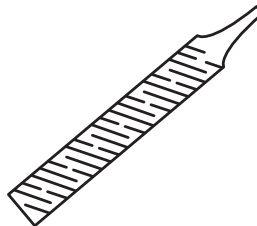

File

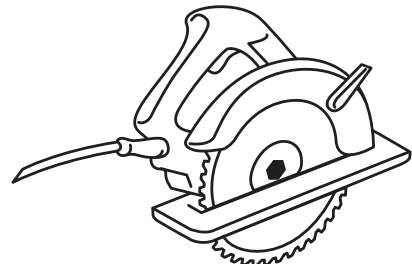

Rotary Saw

# Module Planning

## Layout Options

Want to add some customization?

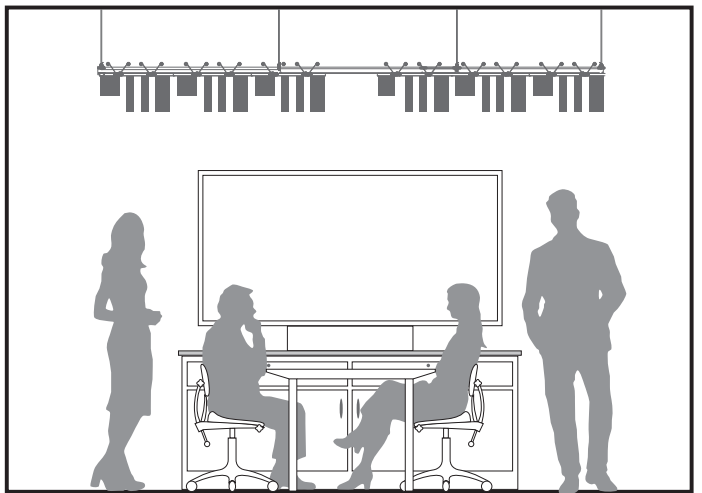
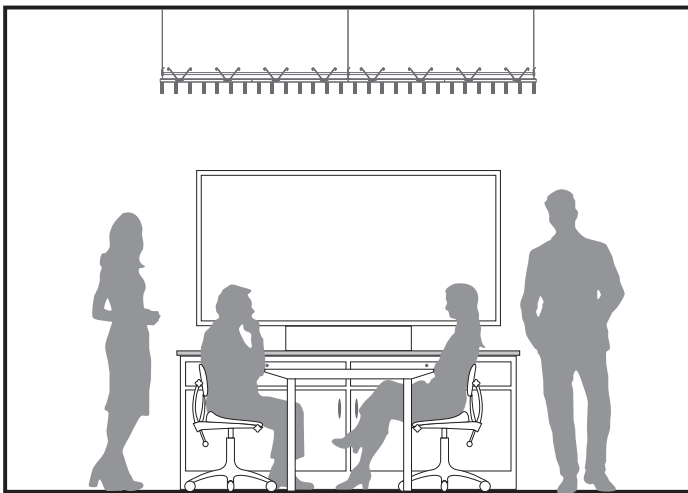
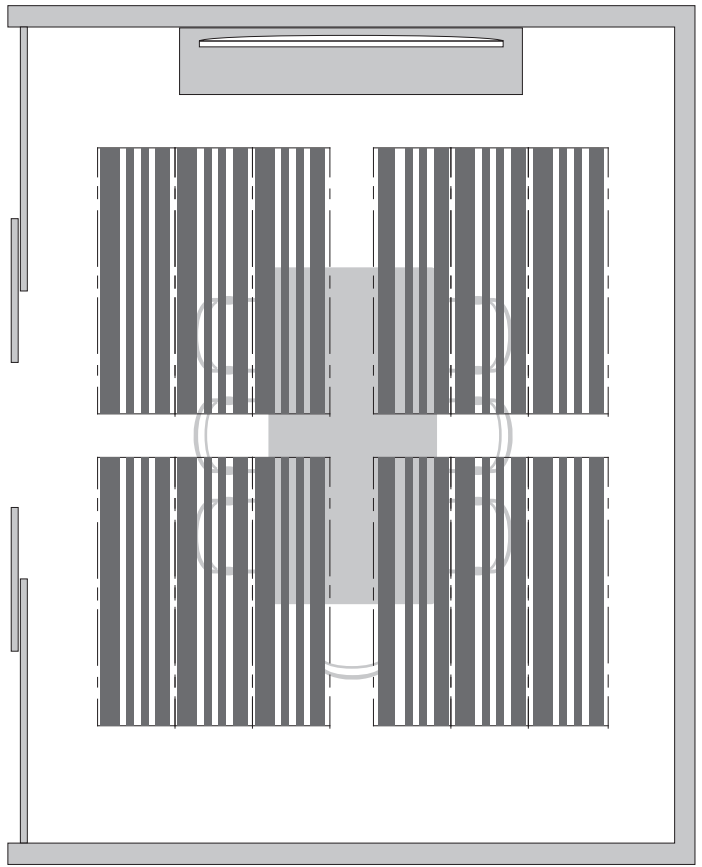
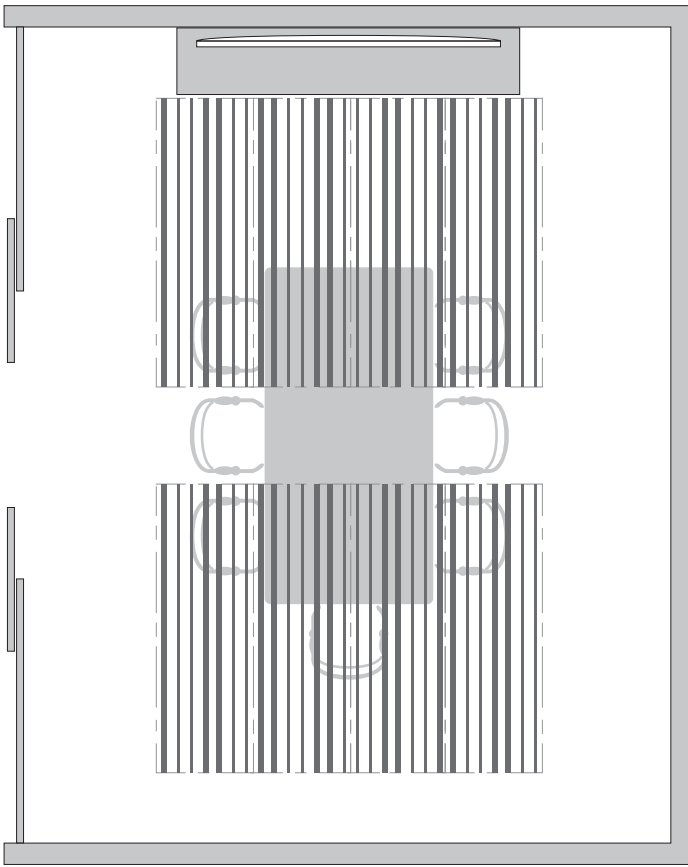

A good layout is always important when designing your space.

# Module Planning

## Layout Options

The options are endless.

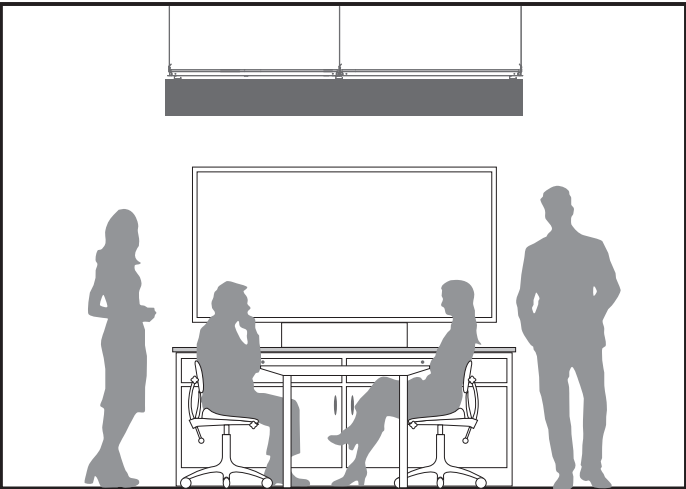
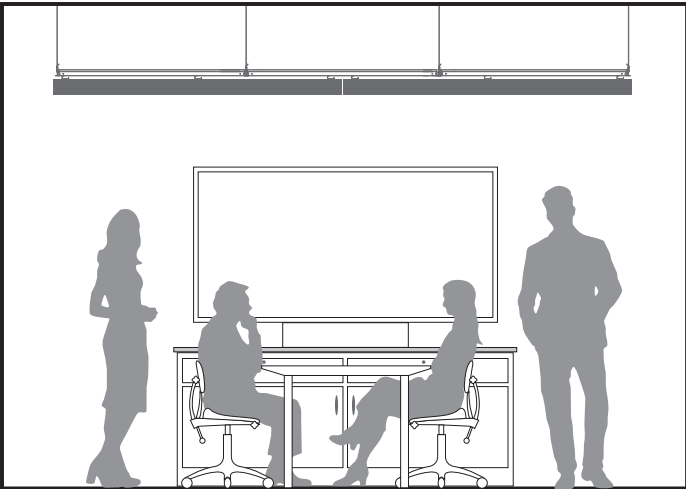
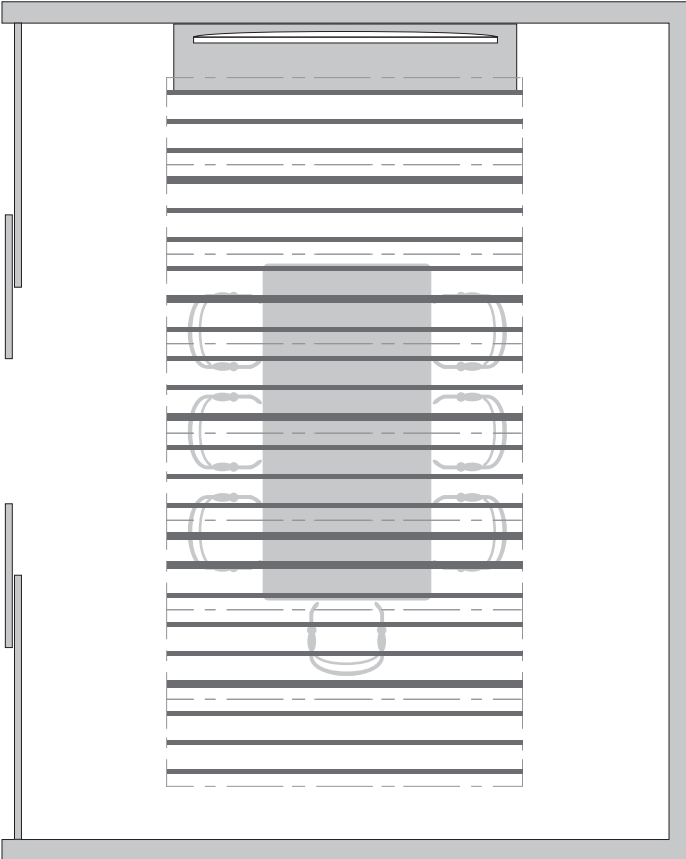
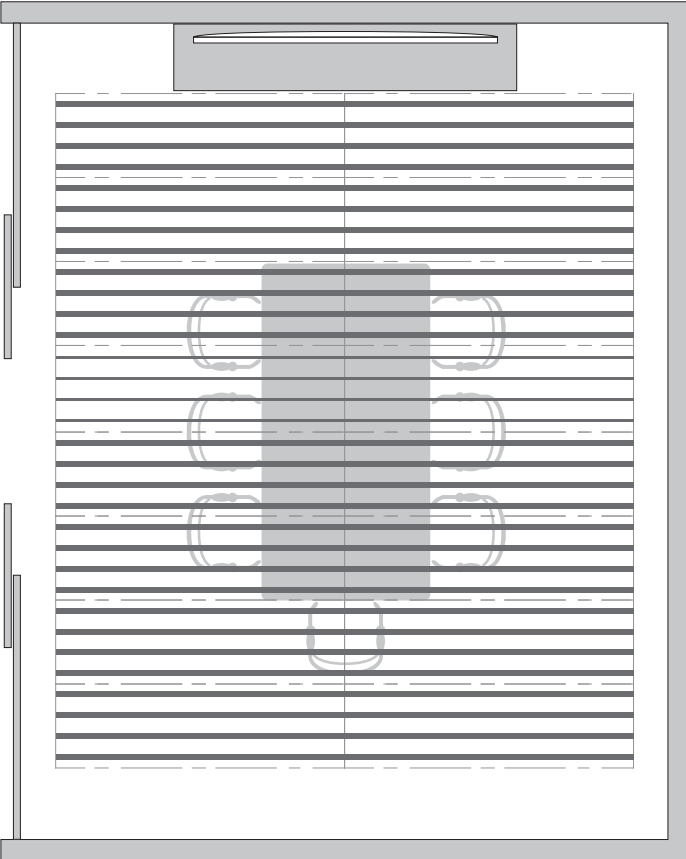

Above are some examples to help get you started.



**Grid Planning**  
Blank Grid

Crosses @ 4'⌞ ,Dashed Lines @ 2'⌞

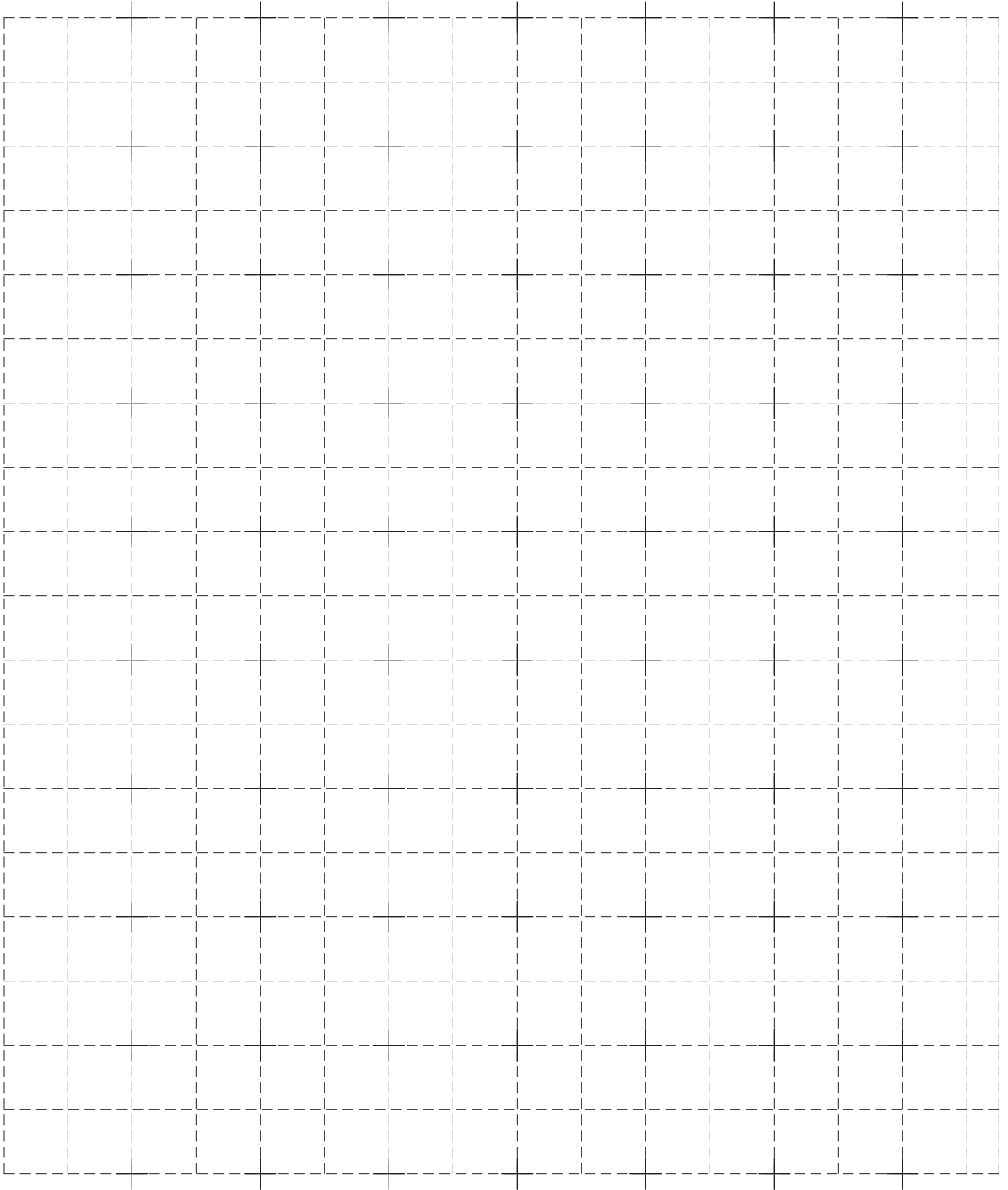

# General Installation

## Install Hanger Wire & Main Tees

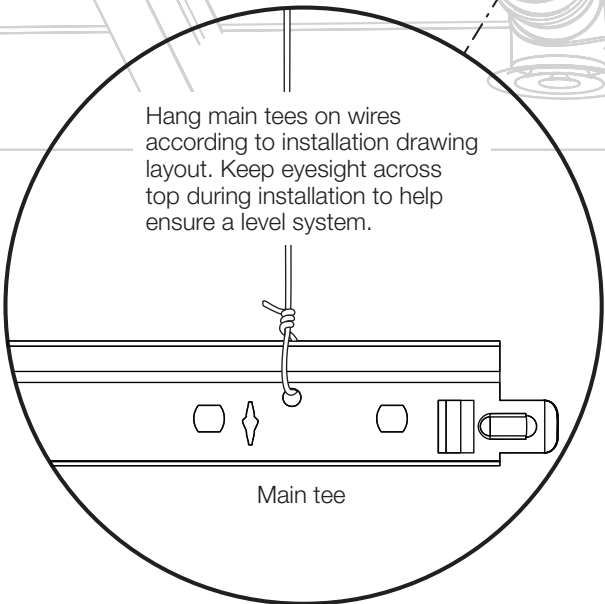
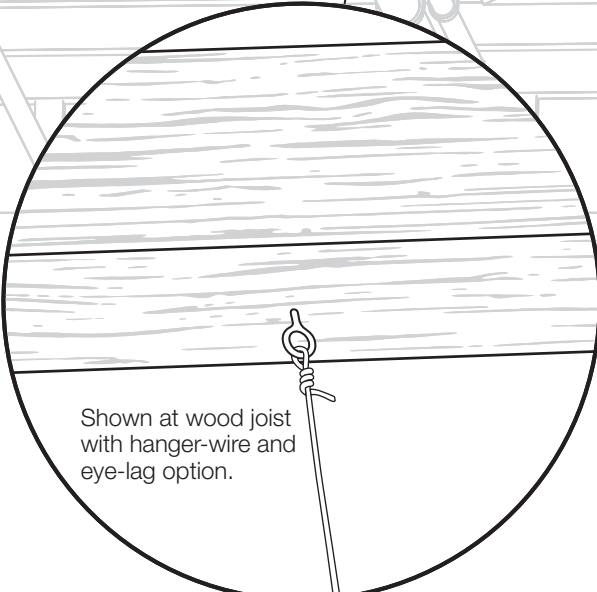
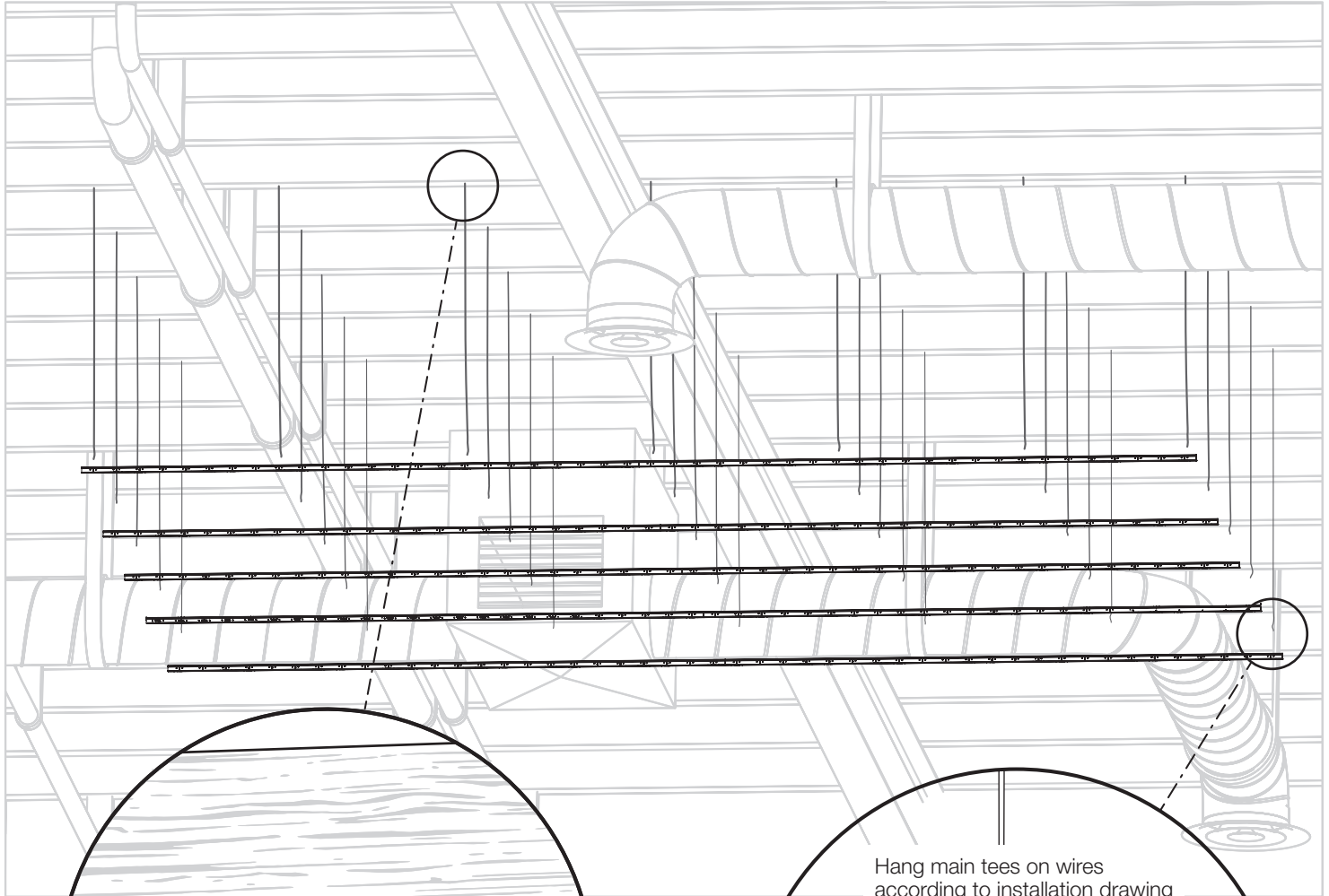

Install per ASTM C636 and ASTM E580 specifications. Select the correct fastener based on your field conditions, i.e. shot-in pin, anchor bolts, screw/clip, etc.

Install additional bracing required for project's seismic codes. Lateral bracing wires/compression posts. For lateral bracing, counter-splayed wires or diagonal bracing are required for each direction.

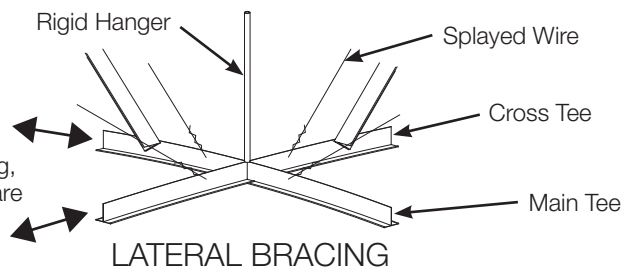

# General Installation

## Install Cross Tees

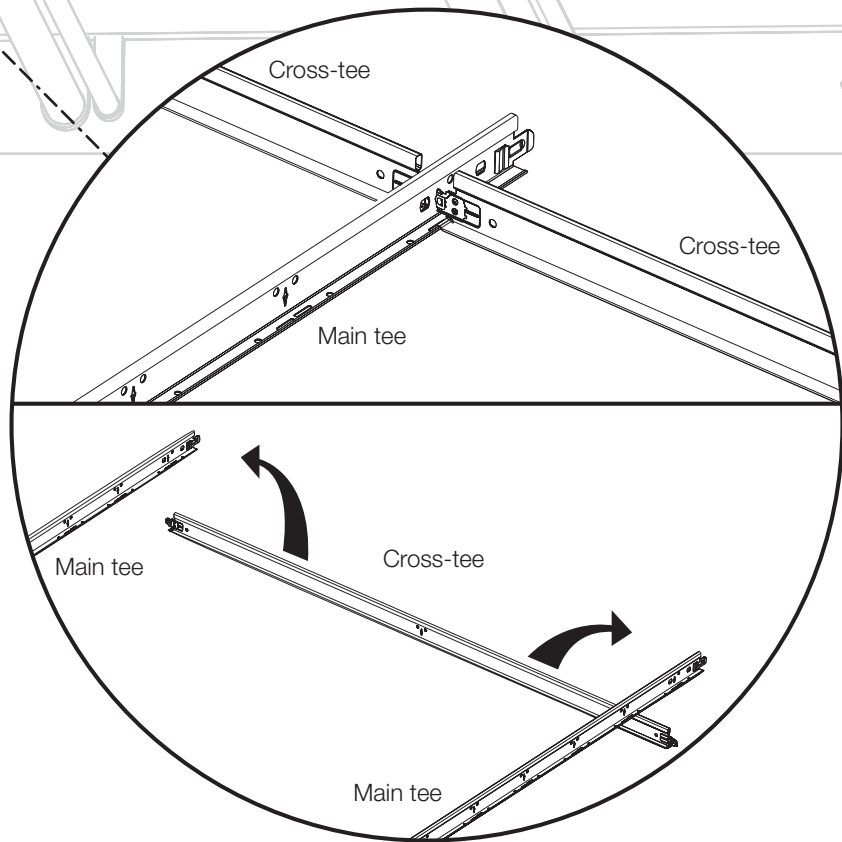
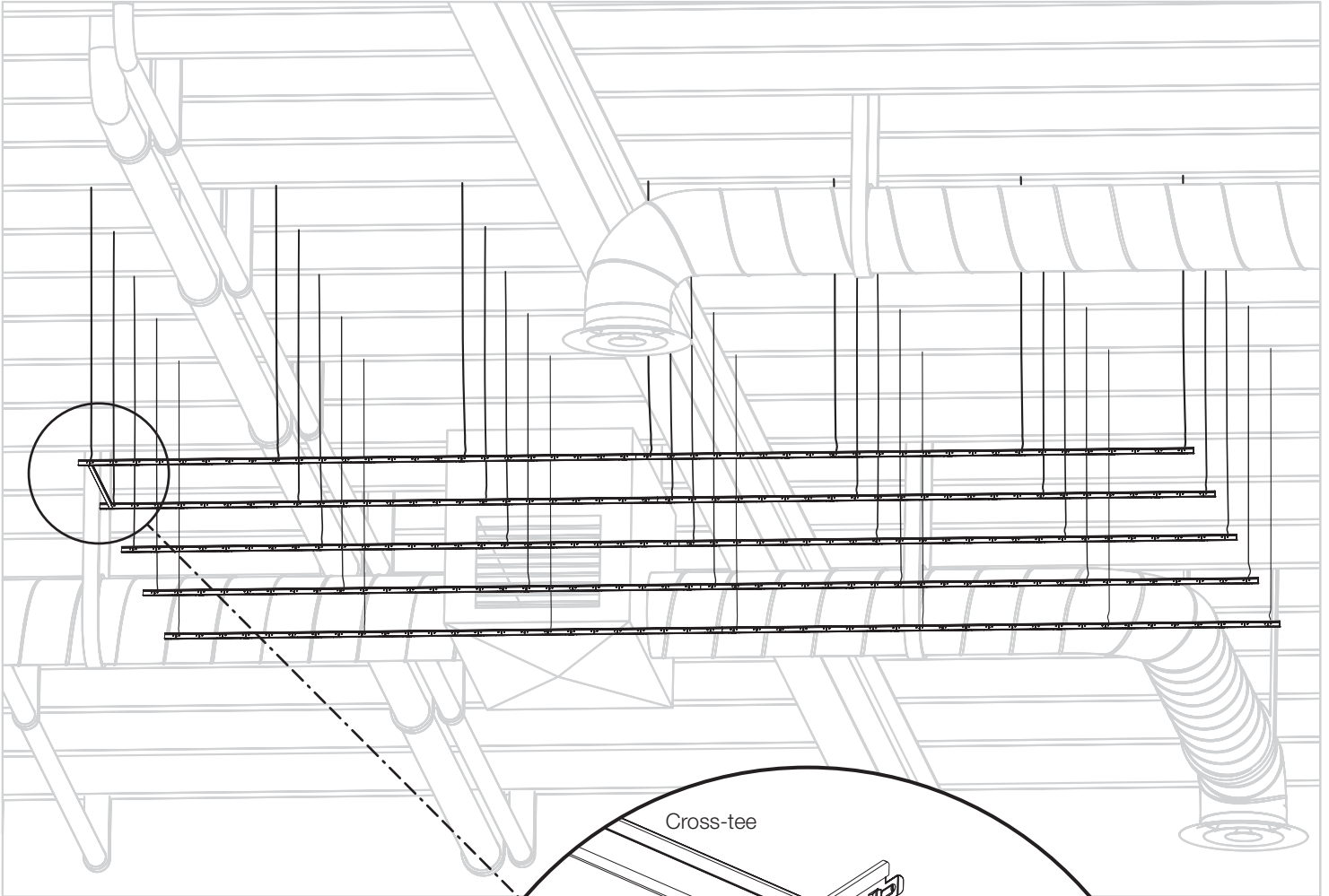

Install cross-tees into main tees with 48" maximum  $\varnothing$  spacing. Follow installation drawing layout.



# General Installation

## Level Grid System

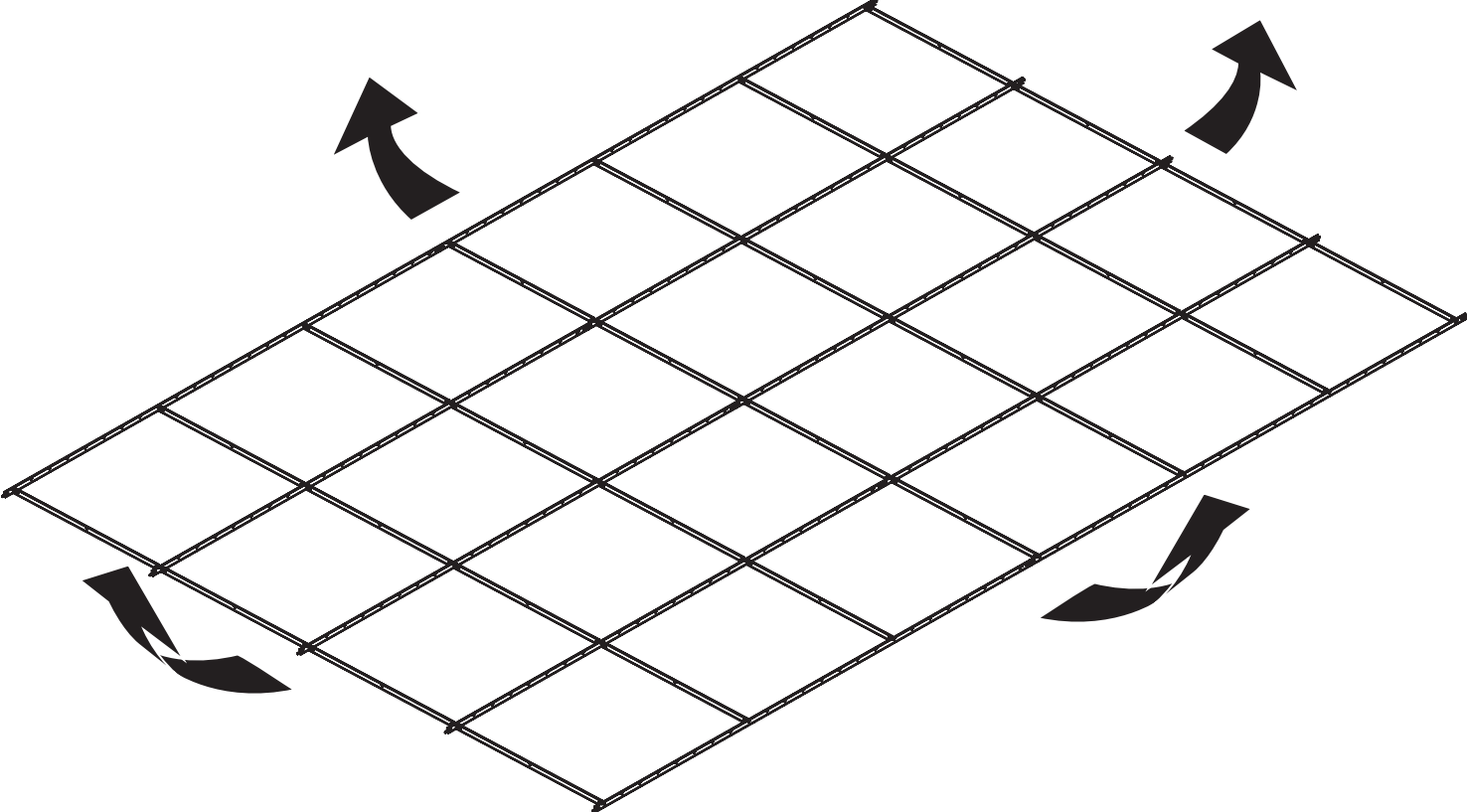

Use laser level to ensure whole grid is leveled to a 1/8" maximum variance.

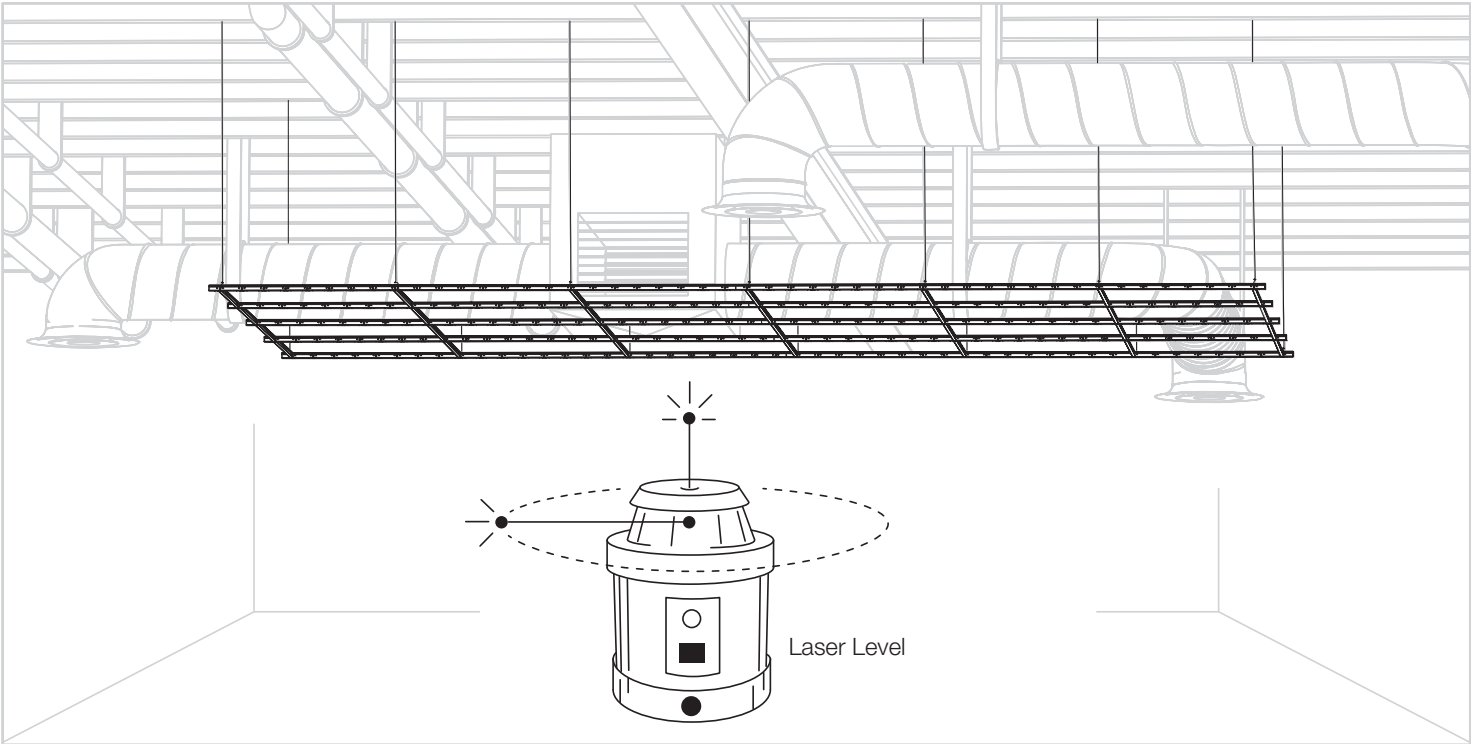

# General Installation

## Install Cassettes Into Grid

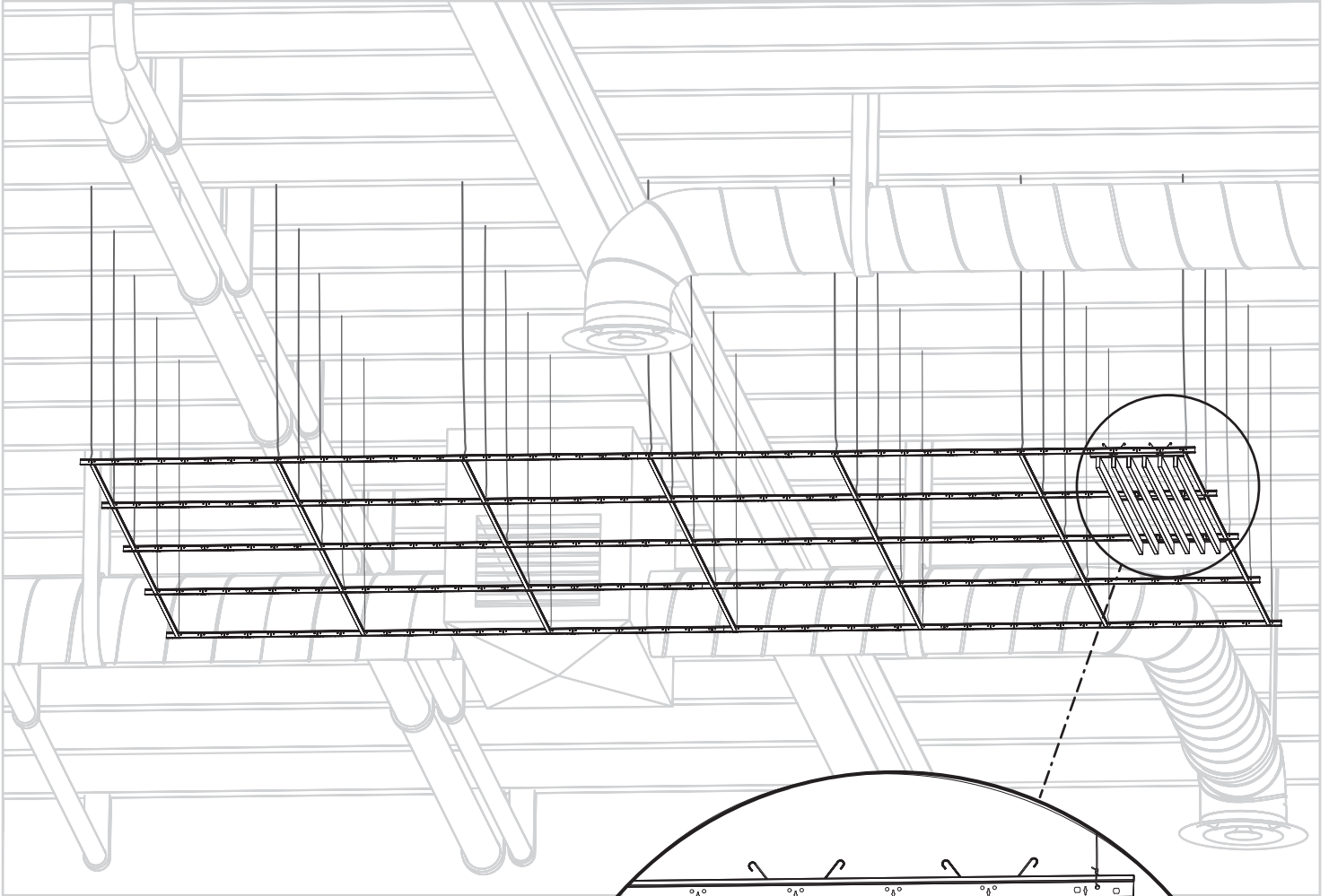

Install cassettes into grid per installation drawings. Pay special attention to orientation.

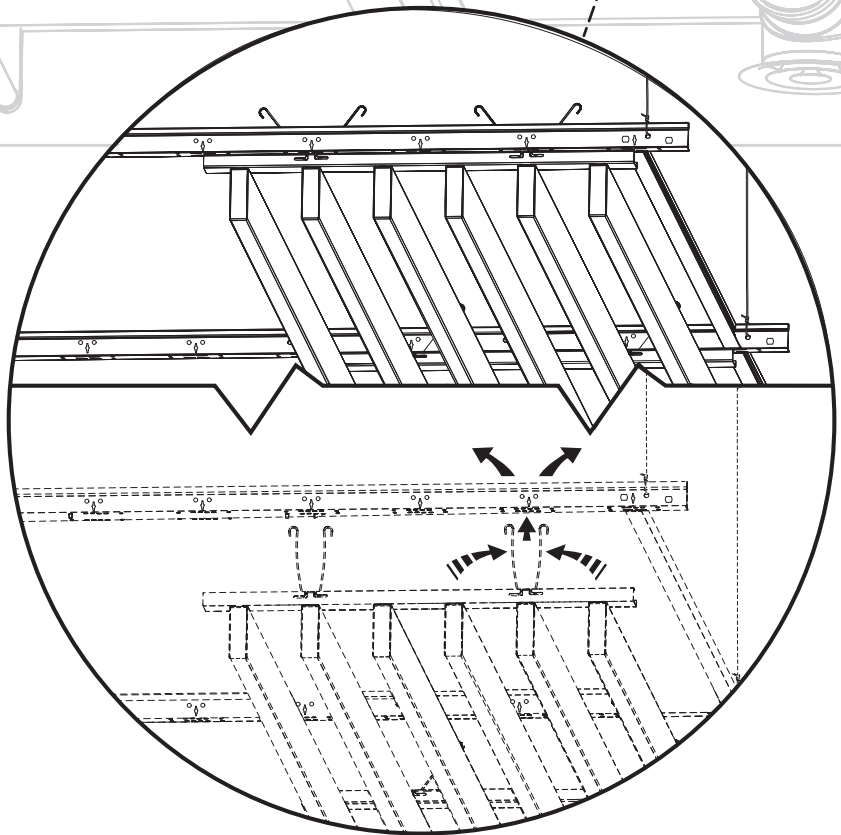
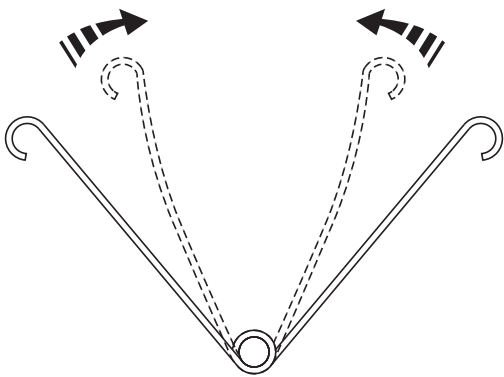

# General Installation

## Fully Installed System

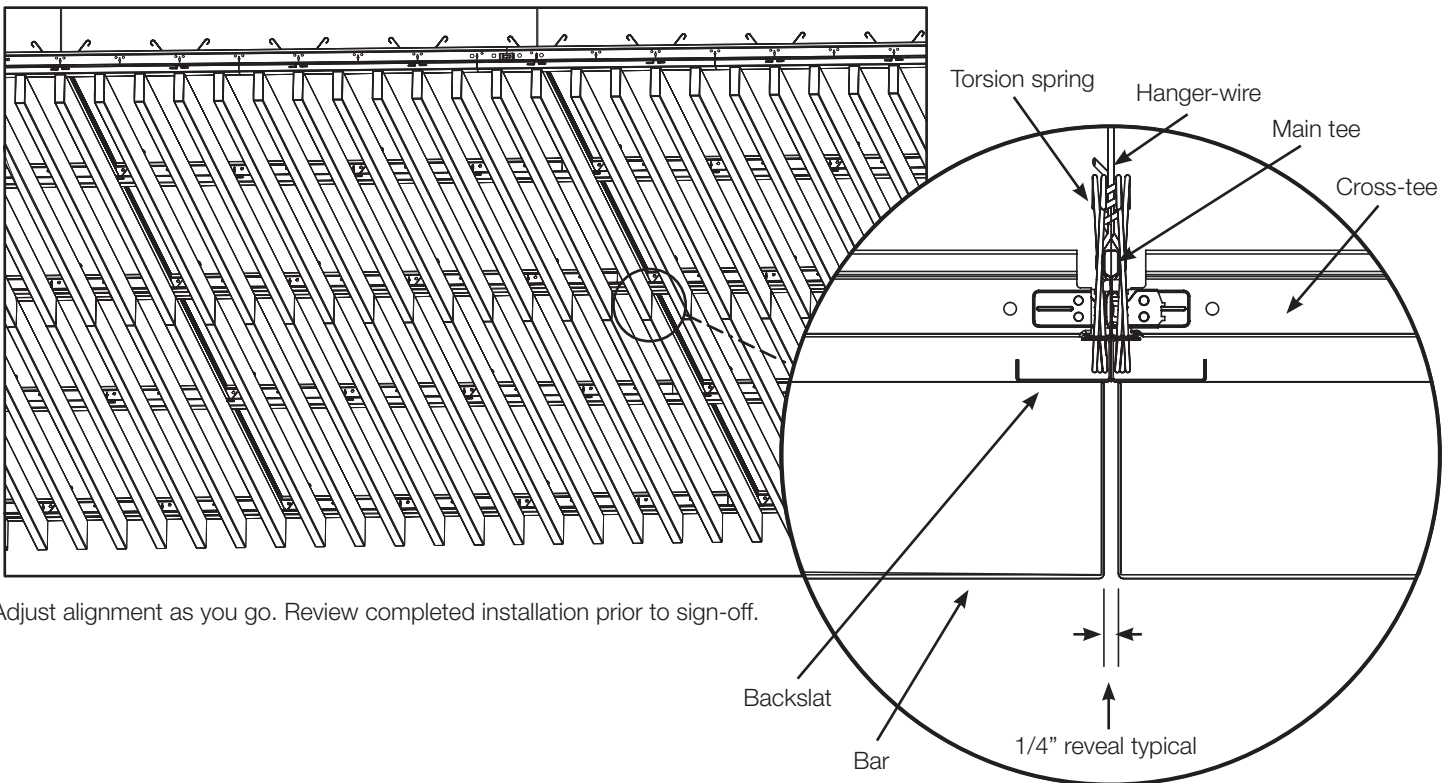
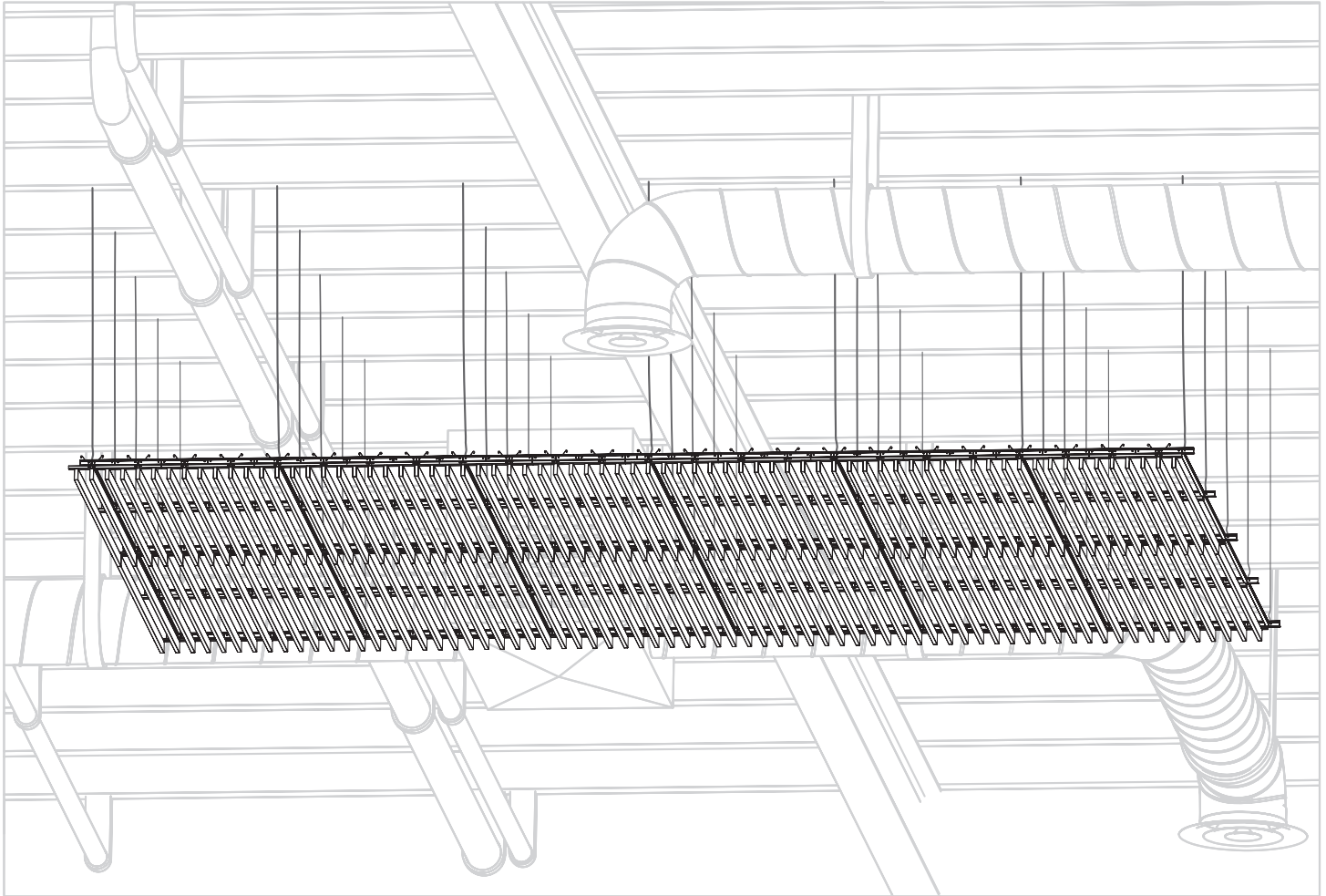

Adjust alignment as you go. Review completed installation prior to sign-off.



# General Installation

## Floating Edge - Grid Concealment

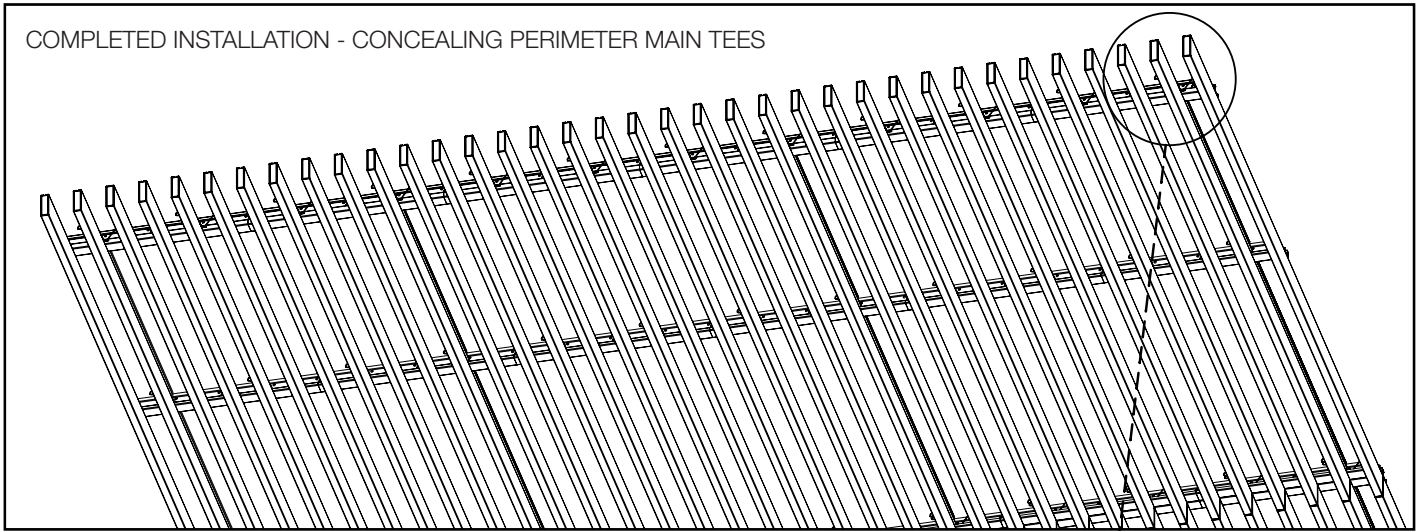

FLOOR VIEW

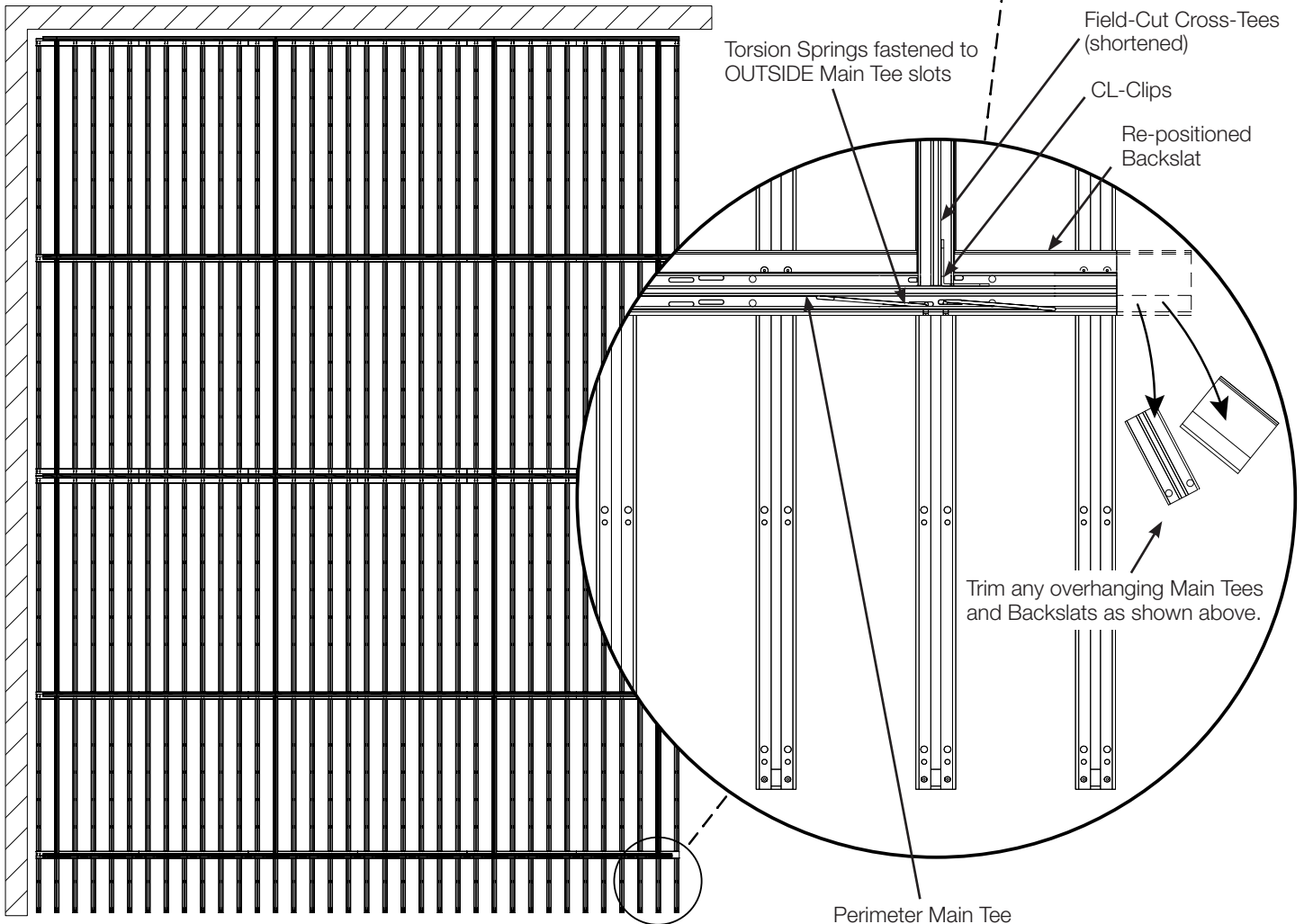

TOP VIEW

# General Installation

## Floating Edge - Grid Concealment

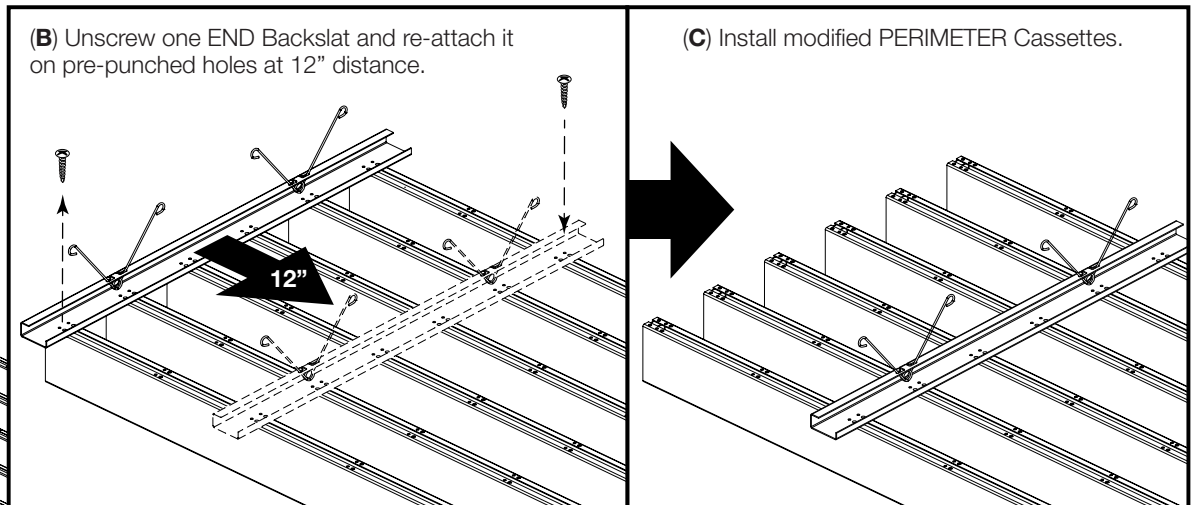
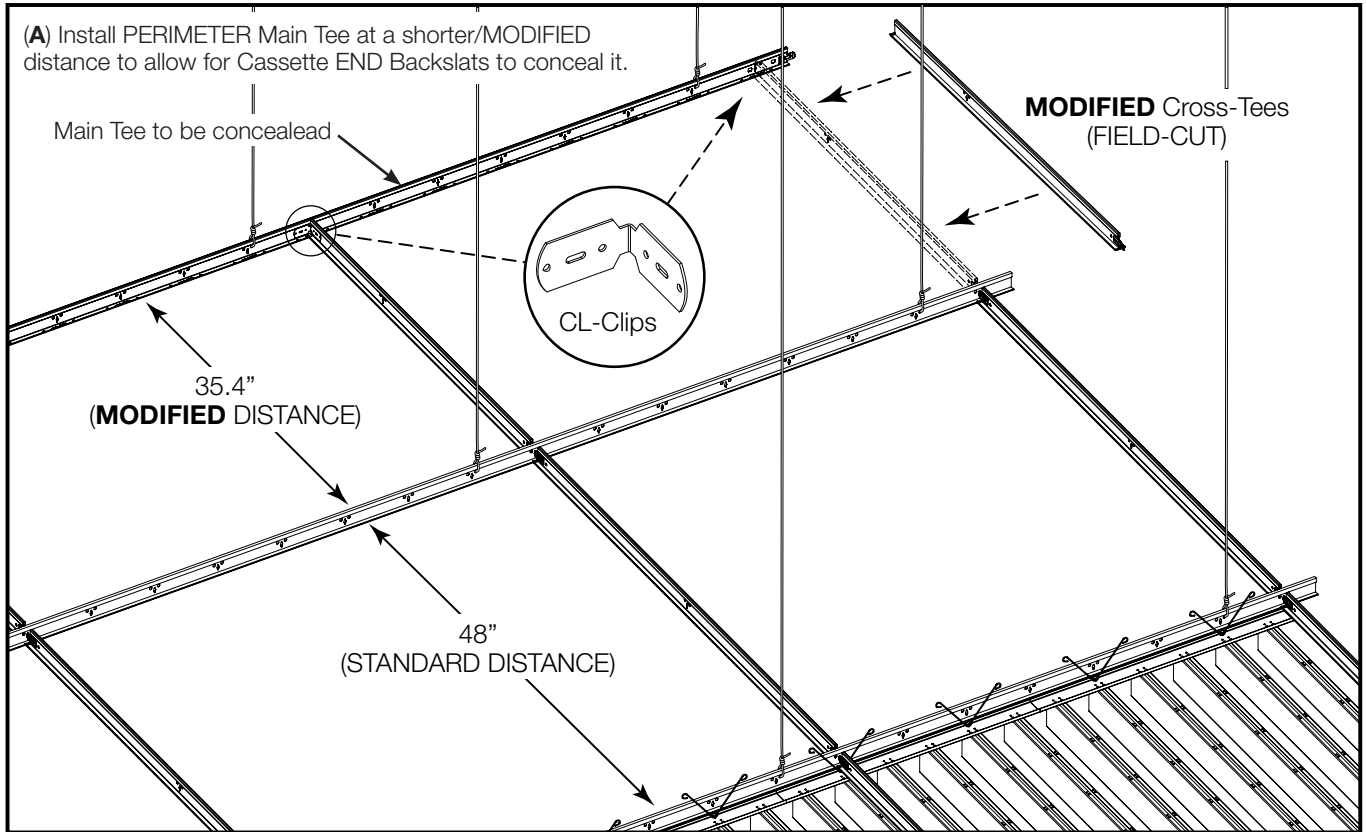

Install cassettes onto grid following previous steps in this manual. Pay special attention to orientation.

# General Installation

## Field Cutting

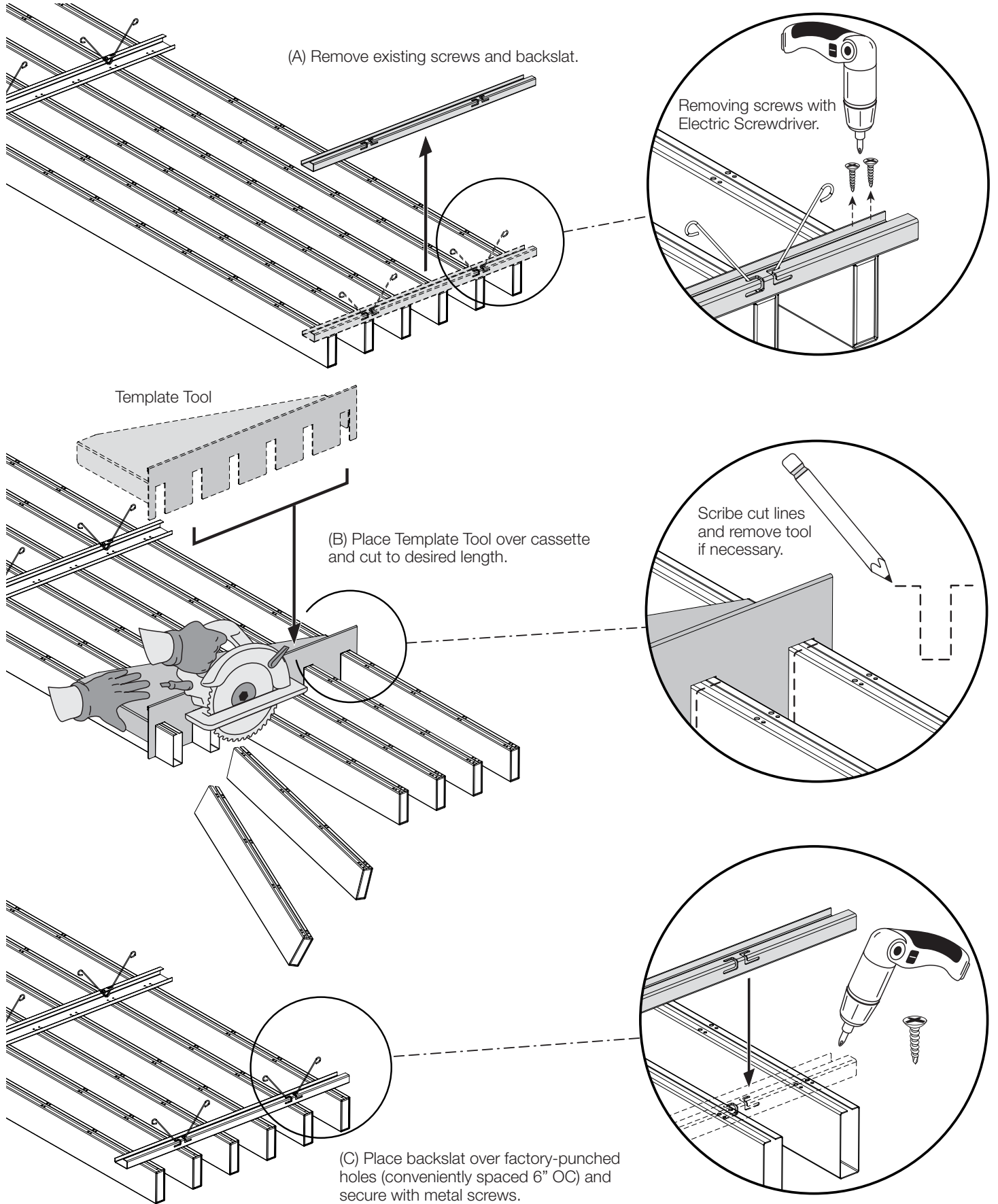

# General Installation

## Field Cutting (2" x 6" Cassette)

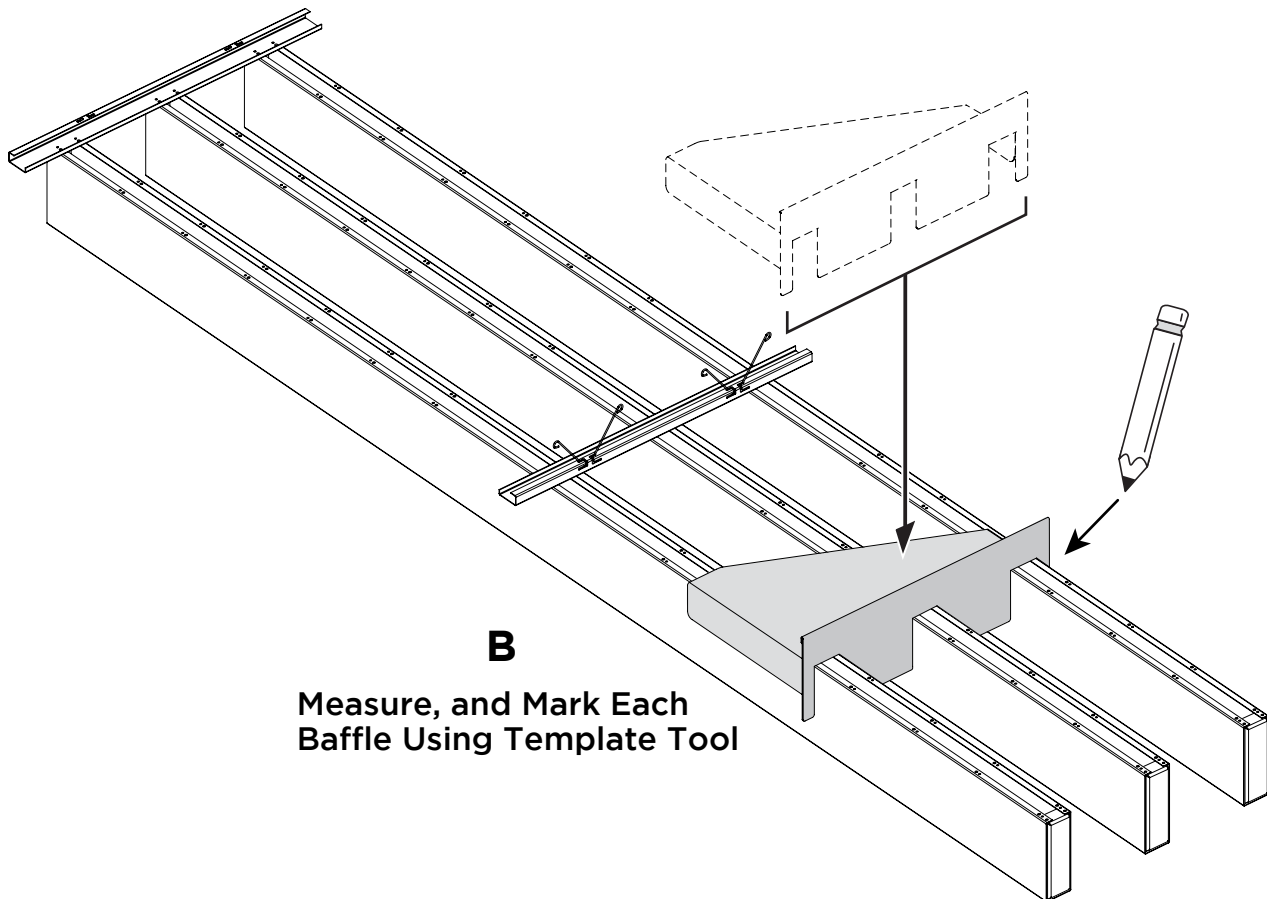
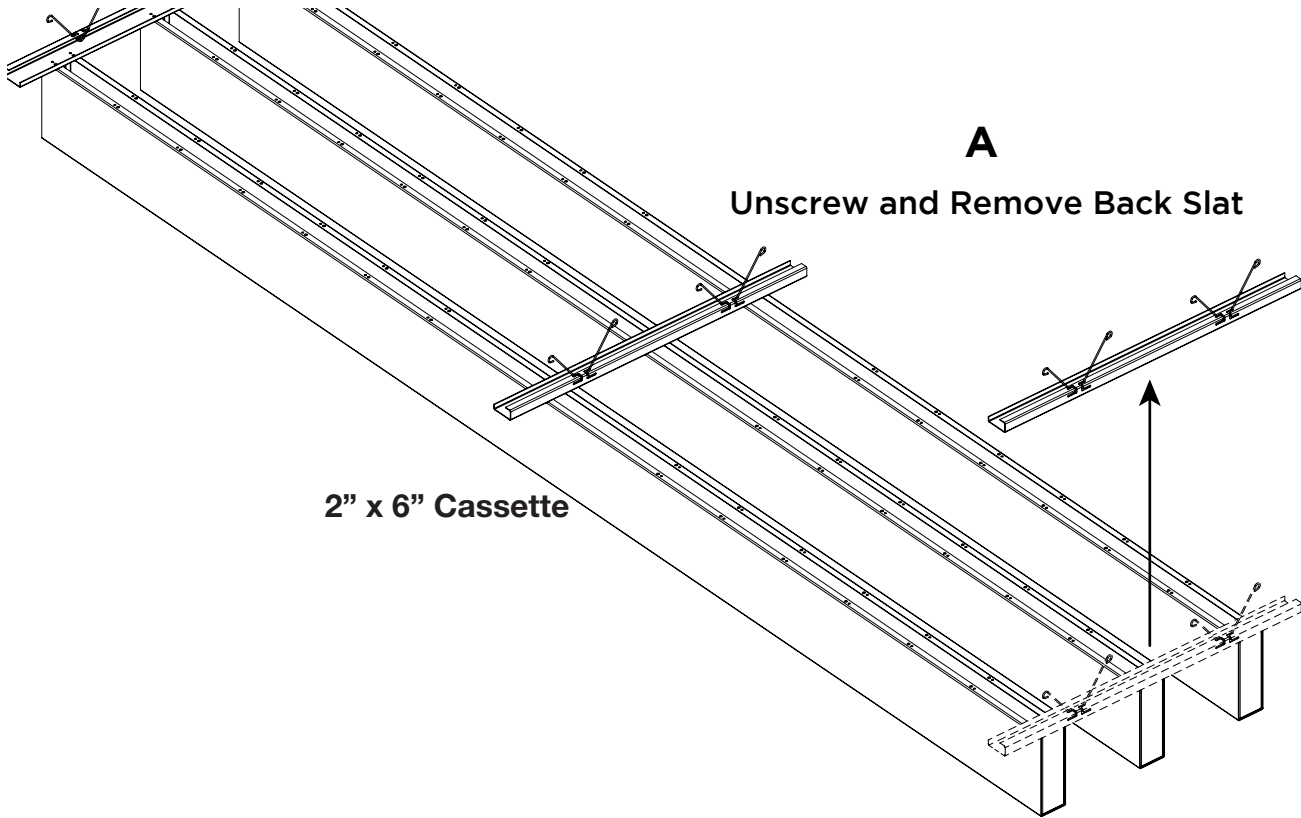

# General Installation

## Field Cutting (2" x 6" Cassette)

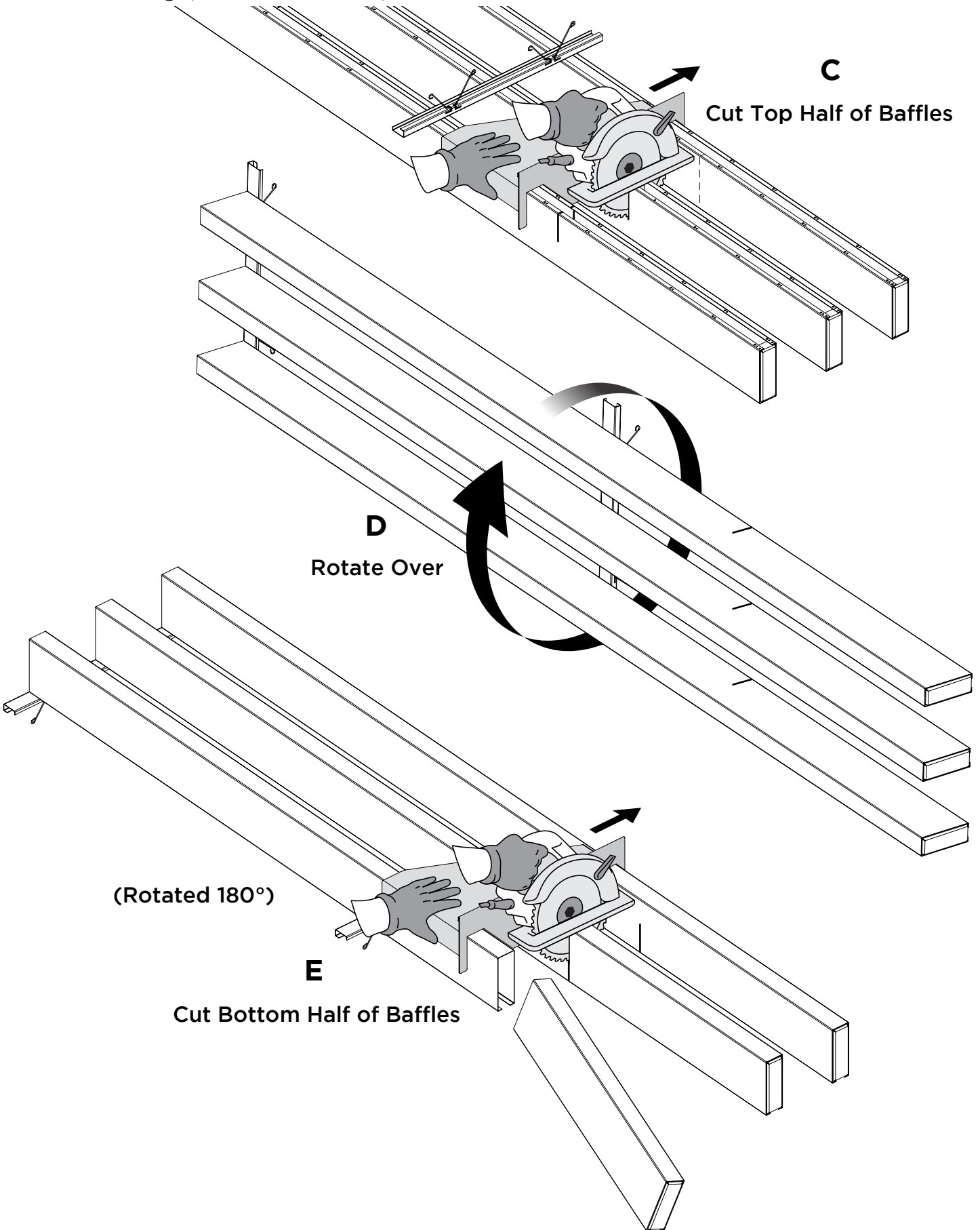



# General Installation

## Field Cutting (2" x 6" Cassette)

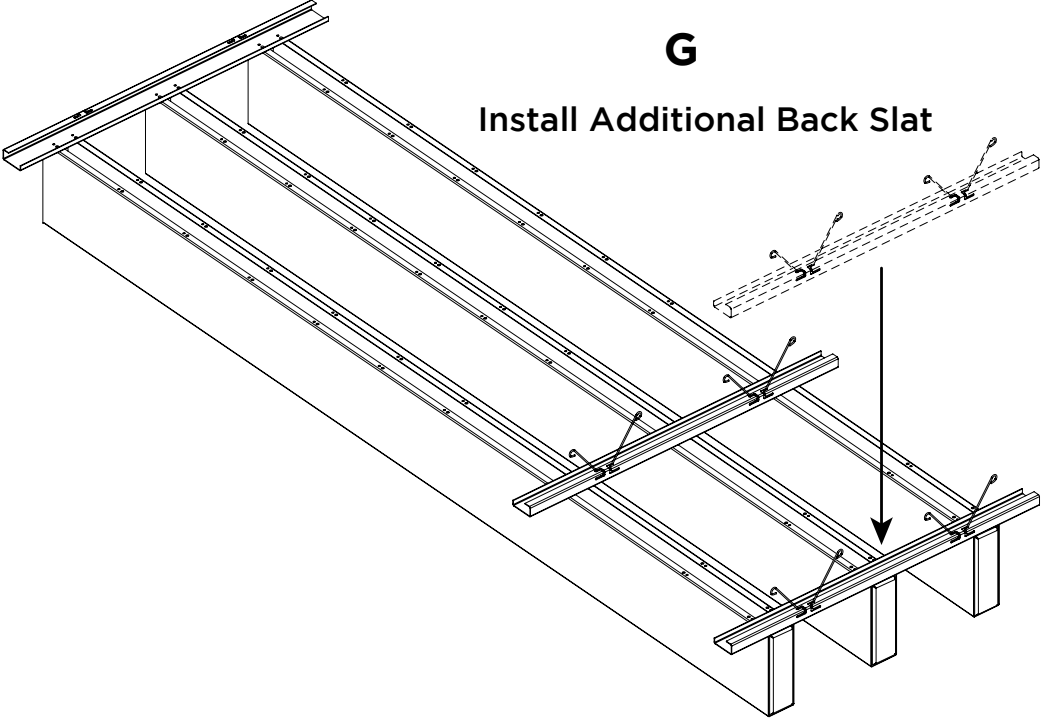
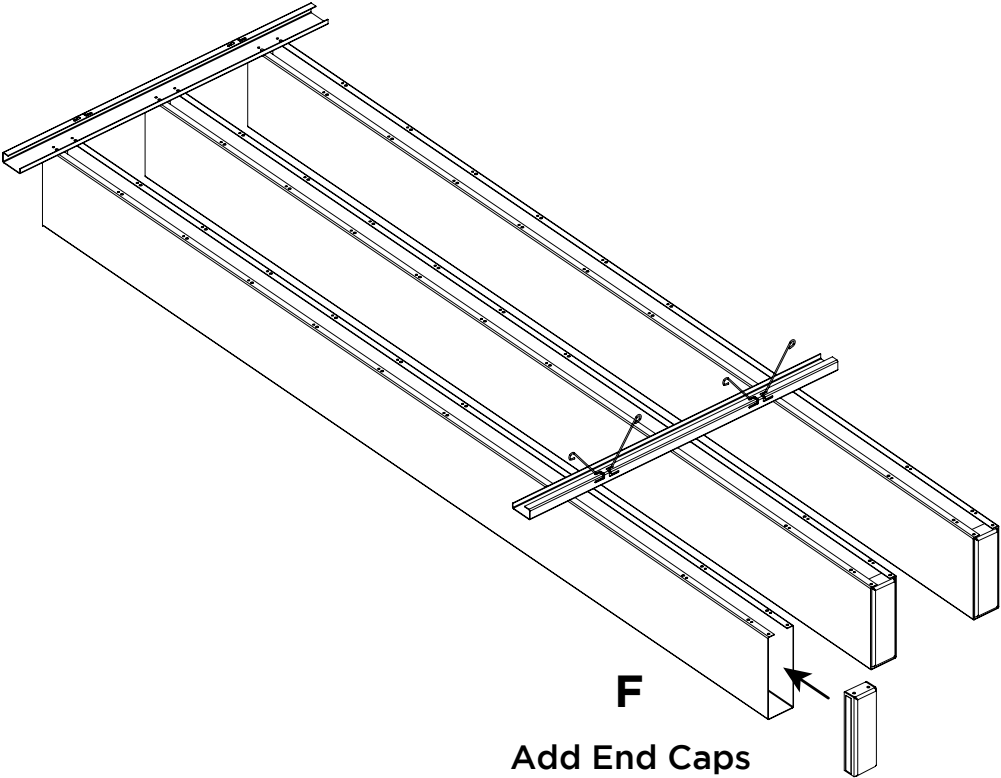

# General Installation

## Field Cutting (2" x 8" Cassette)

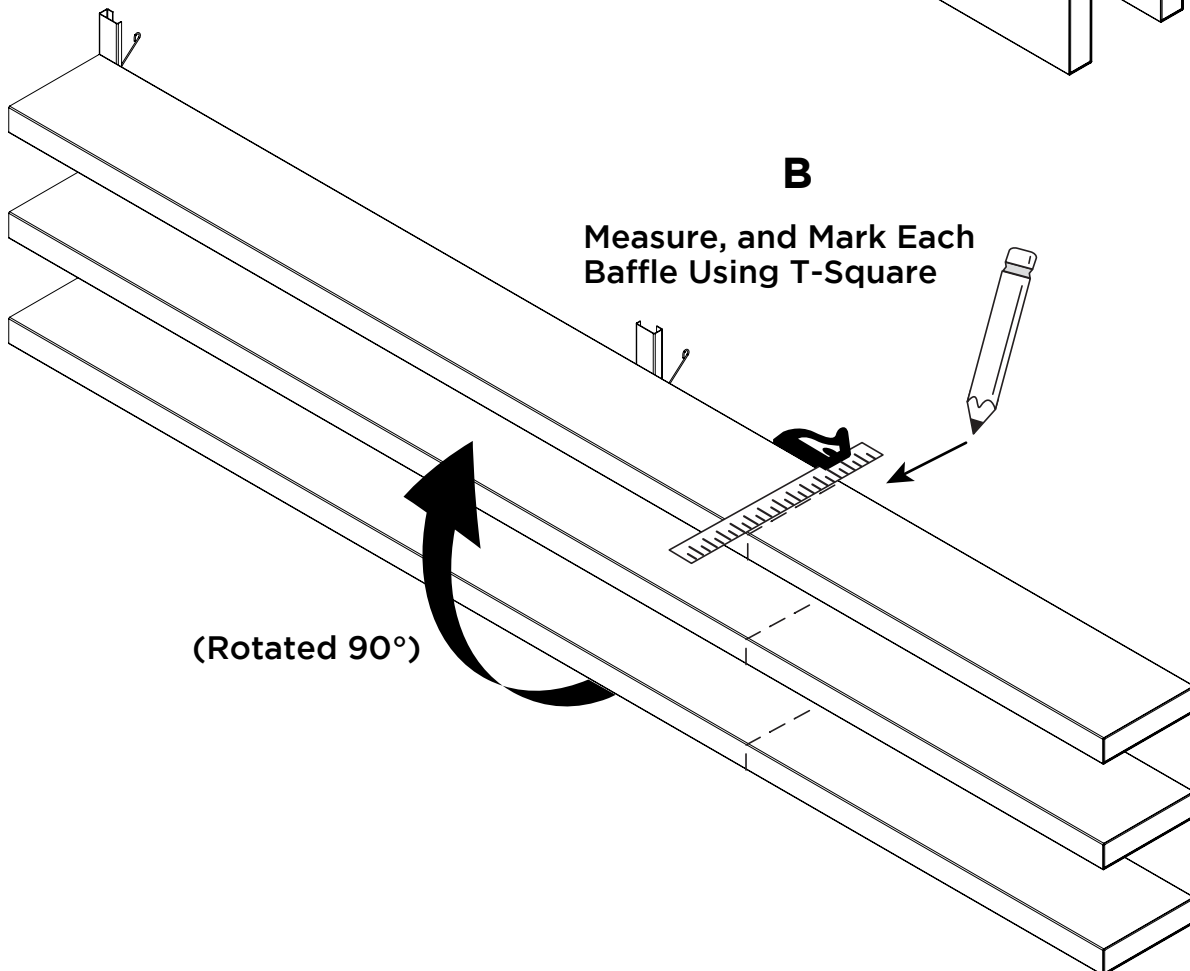
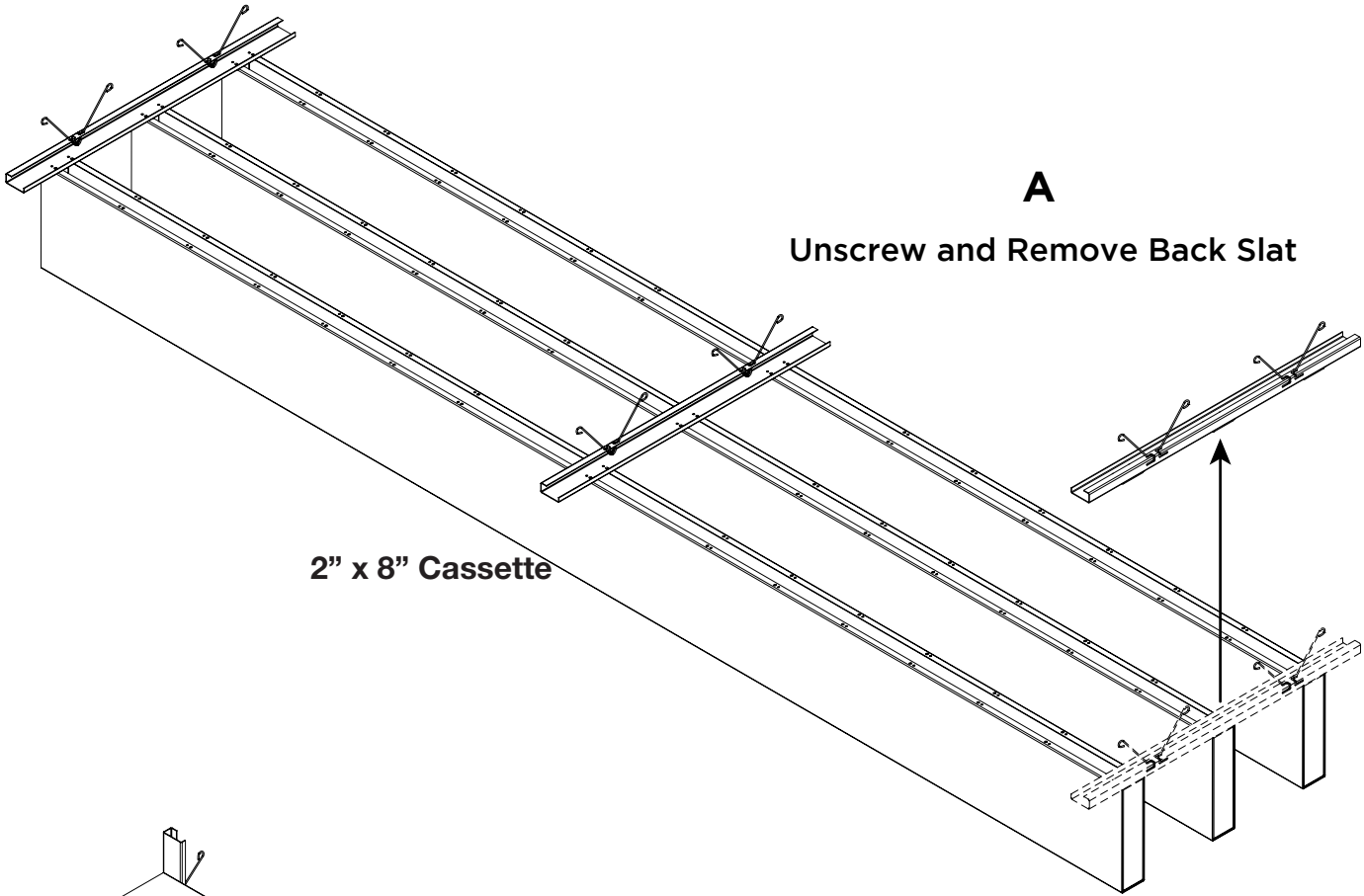

# General Installation

## Field Cutting (2" x 8" Cassette)

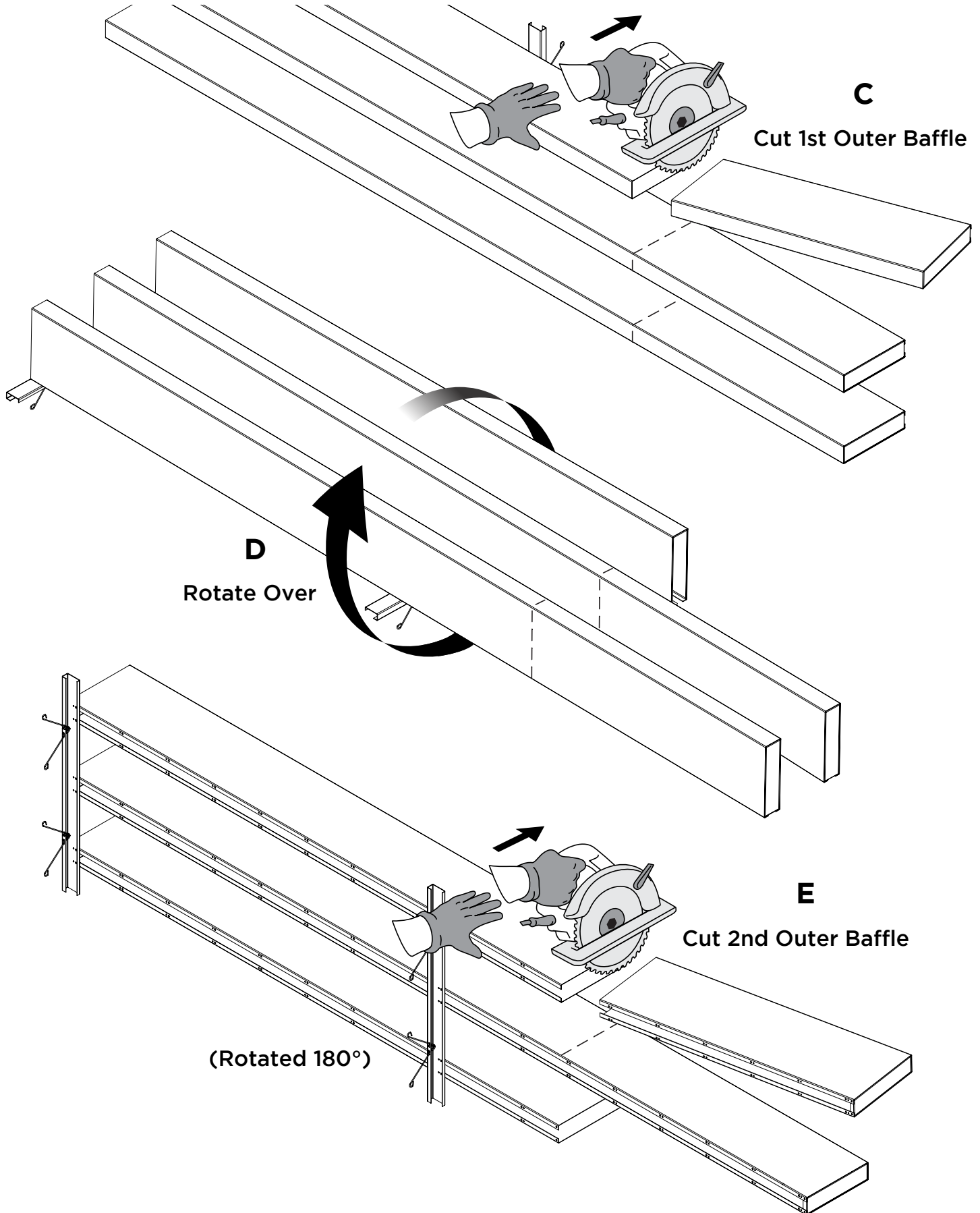

# General Installation

## Field Cutting (2" x 8" Cassette)

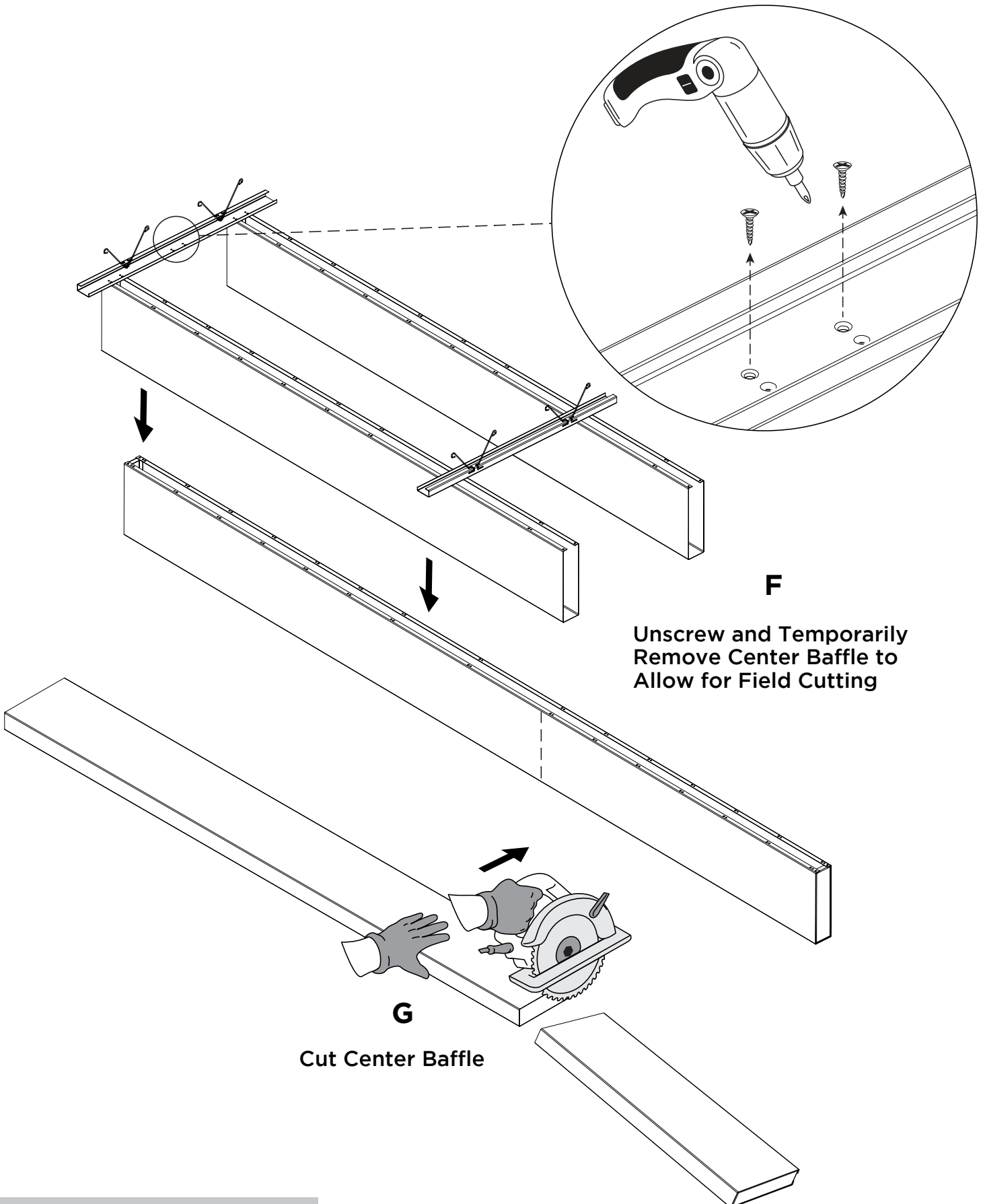

**F**

Unscrew and Temporarily  
Remove Center Baffle to  
Allow for Field Cutting

**G**

Cut Center Baffle

# General Installation

## Field Cutting (2" x 8" Cassette)

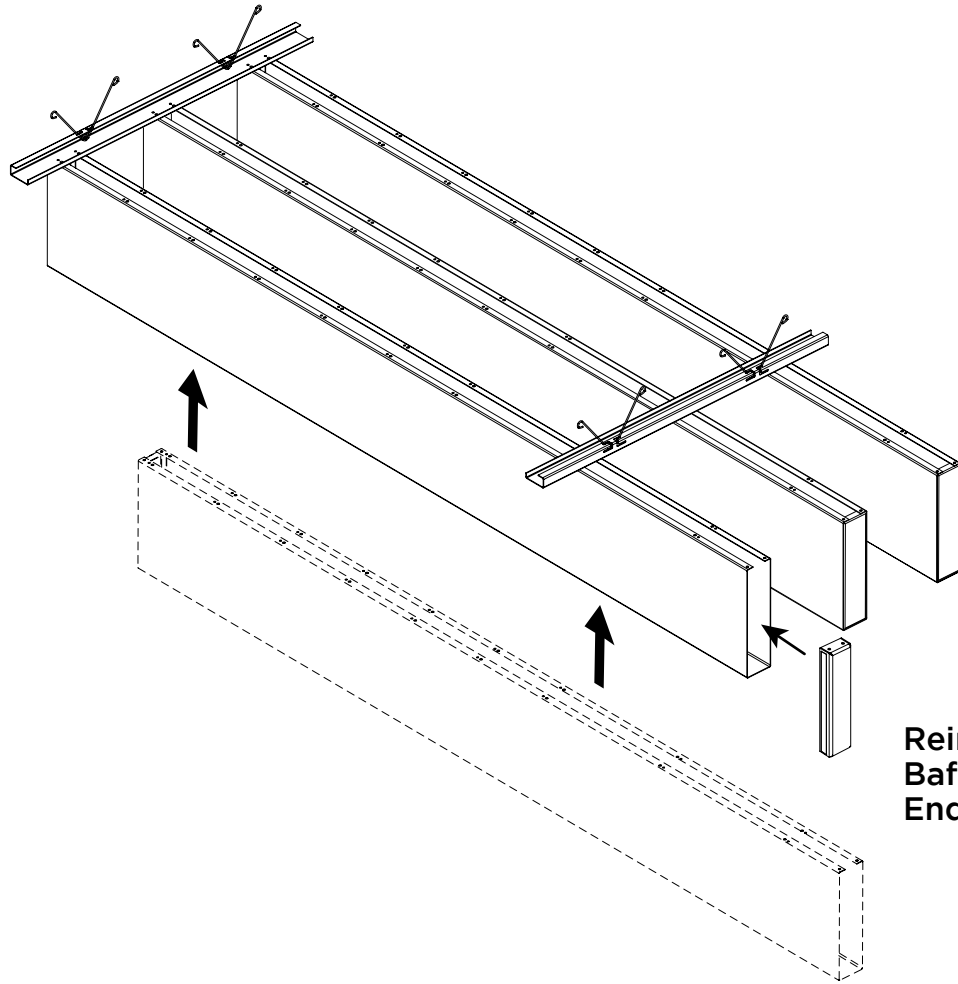

**H**

Reinstall Center  
Baffle and Add  
End Caps

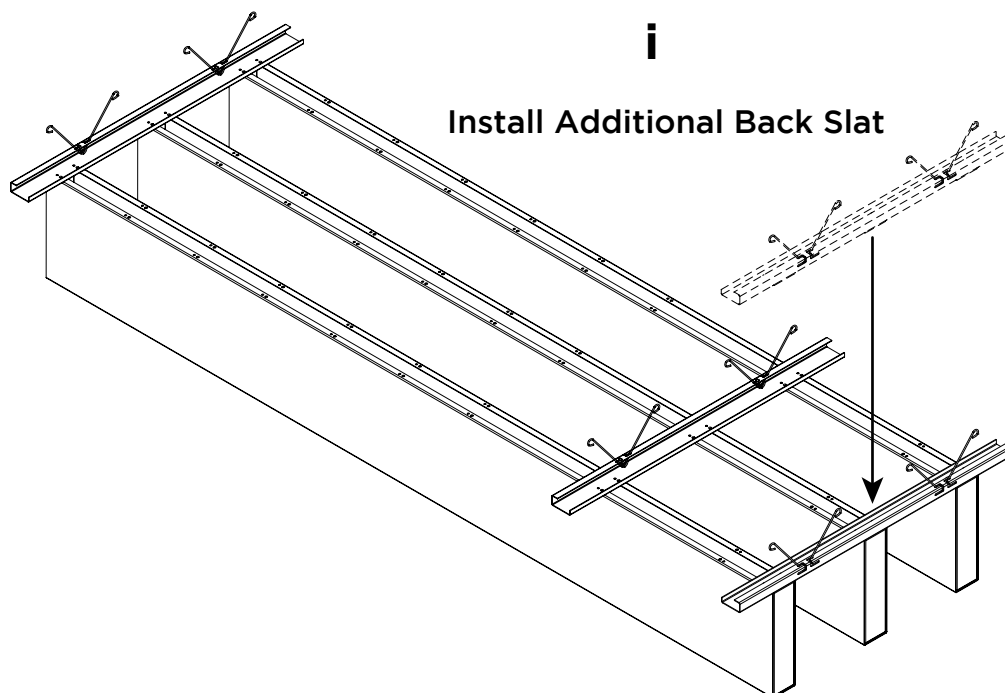

**i**

Install Additional Back Slat



# General Installation

## Installing End-Caps

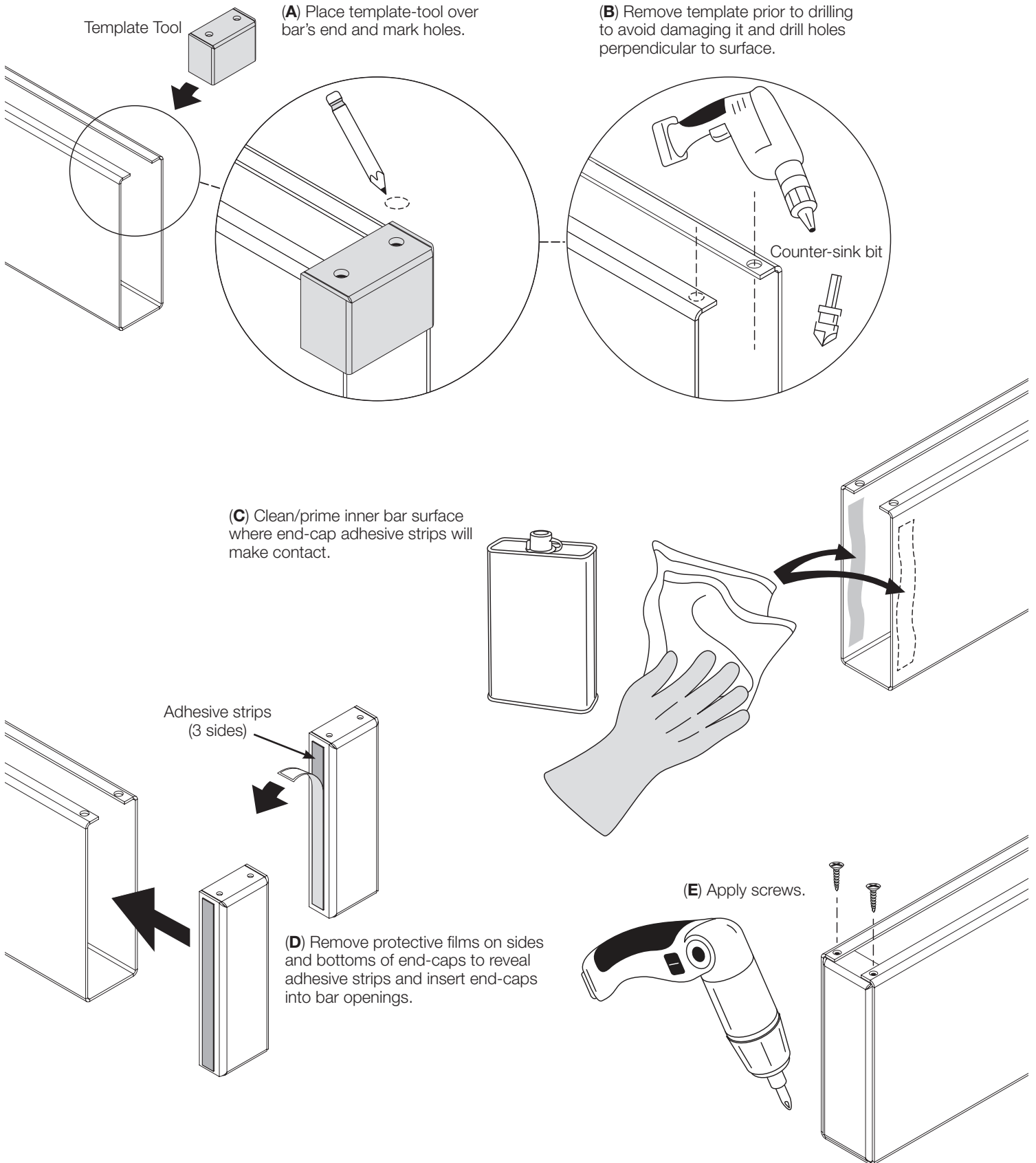

# Perimeter Conditions

## Straight Wall Condition

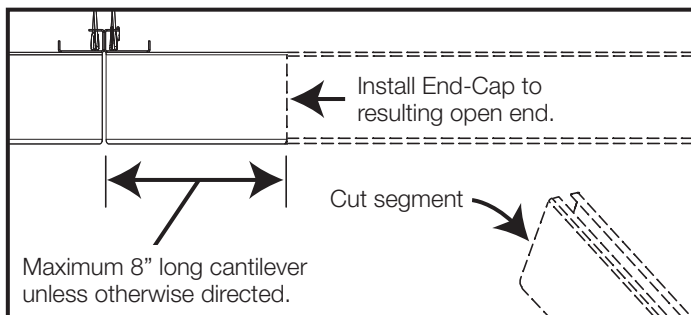
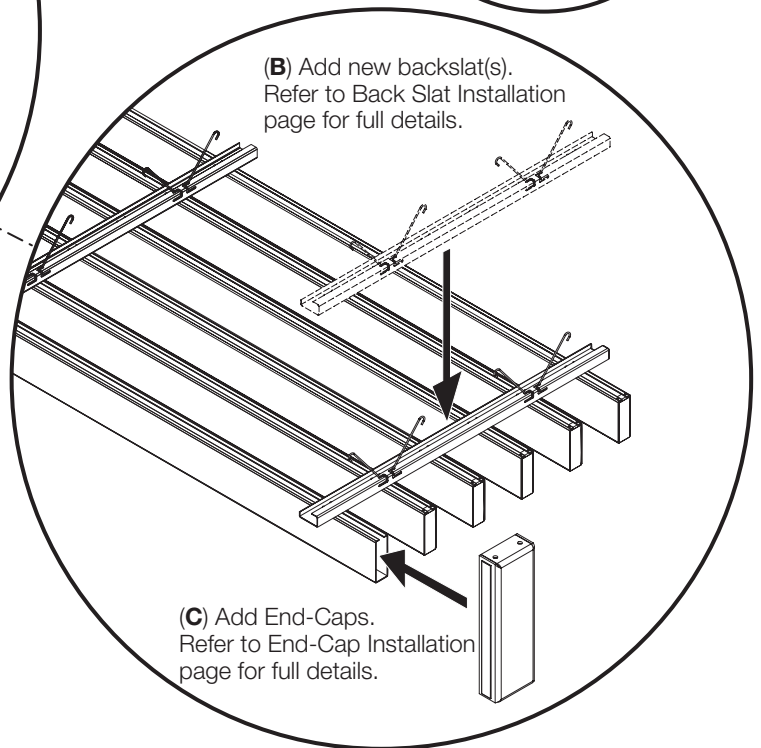
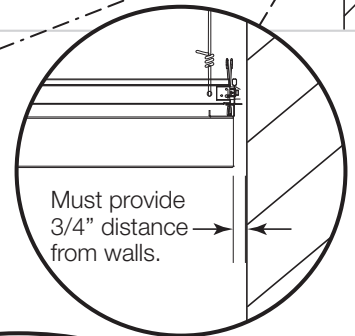
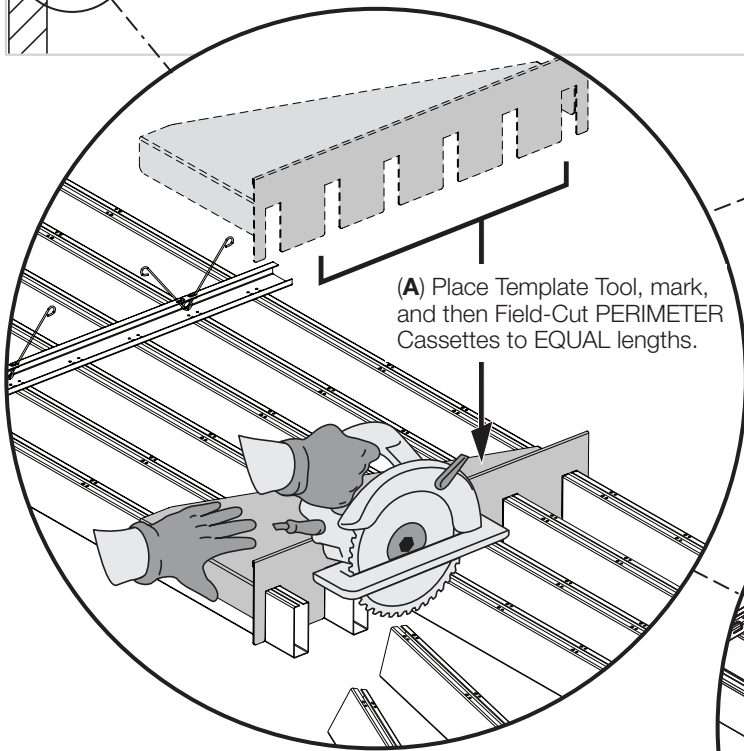
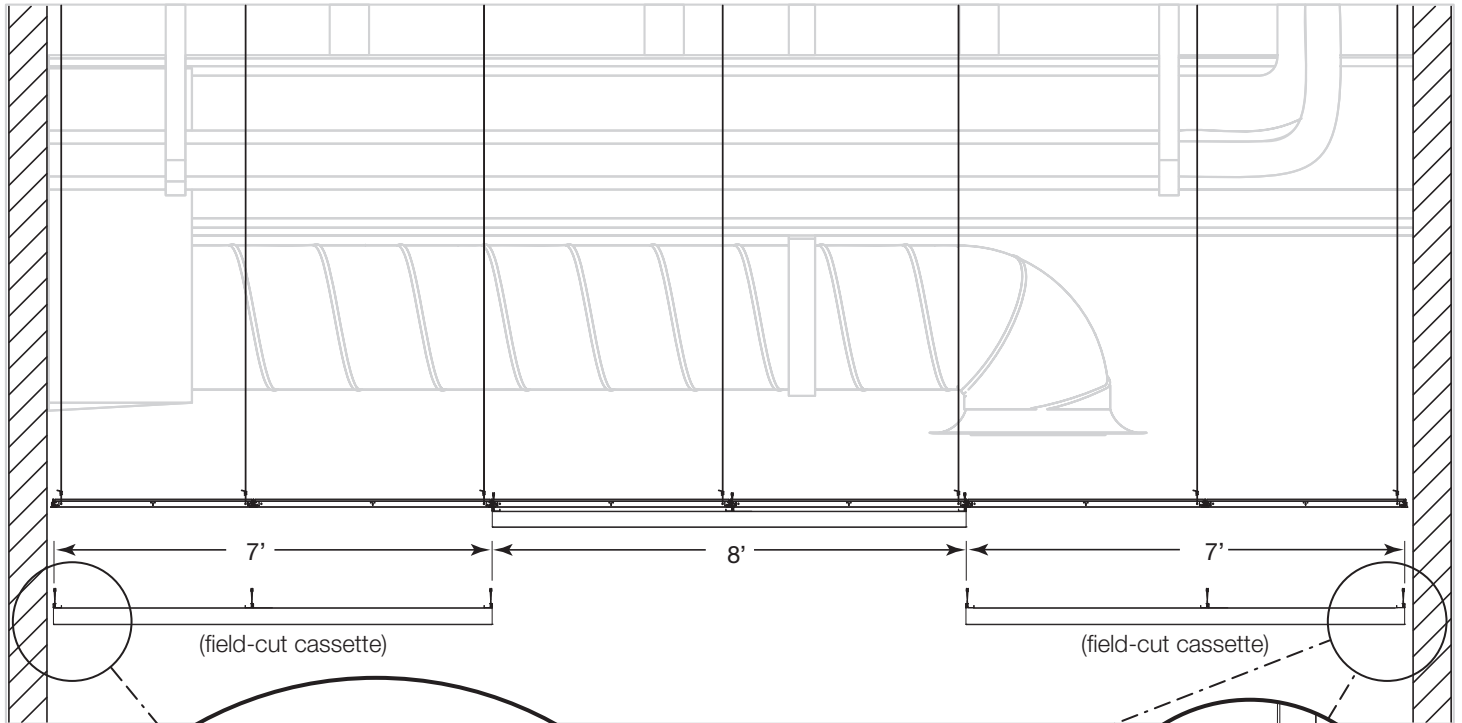

# Perimeter Conditions

## Angled Wall Condition

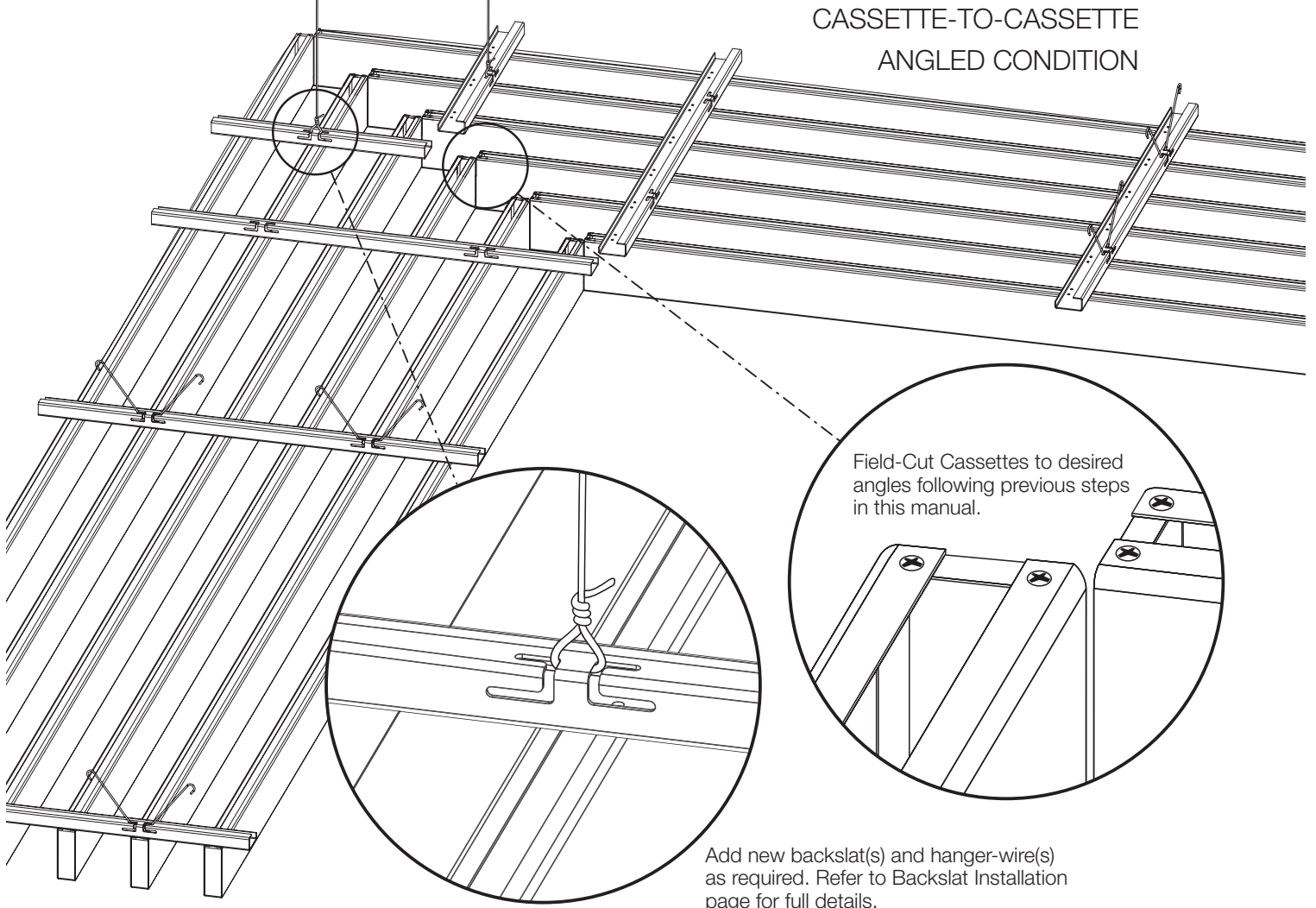
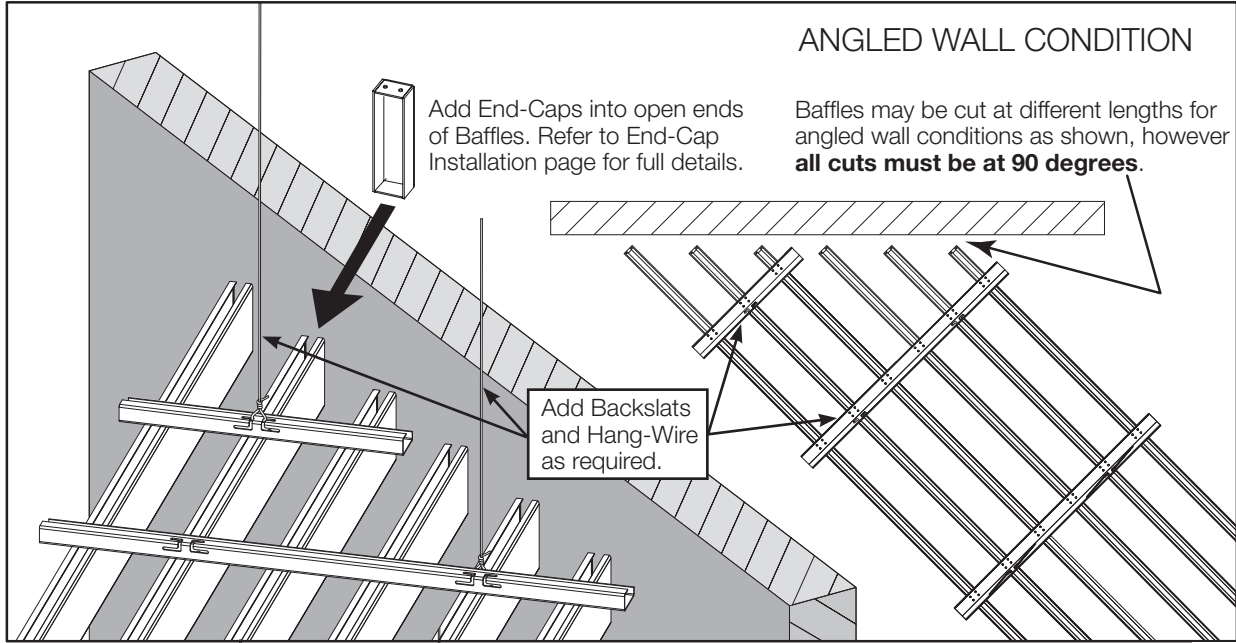

# Perimeter Conditions

## Column Integration

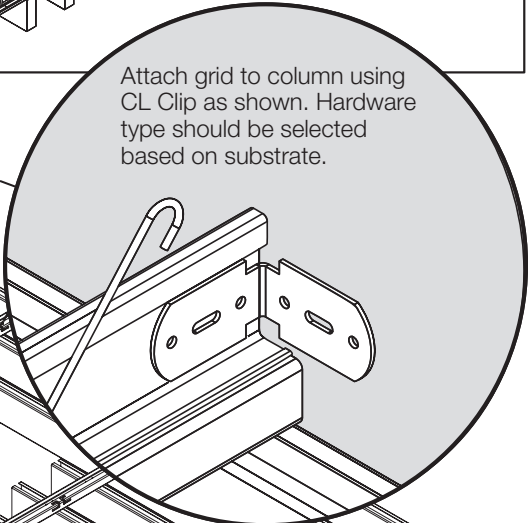
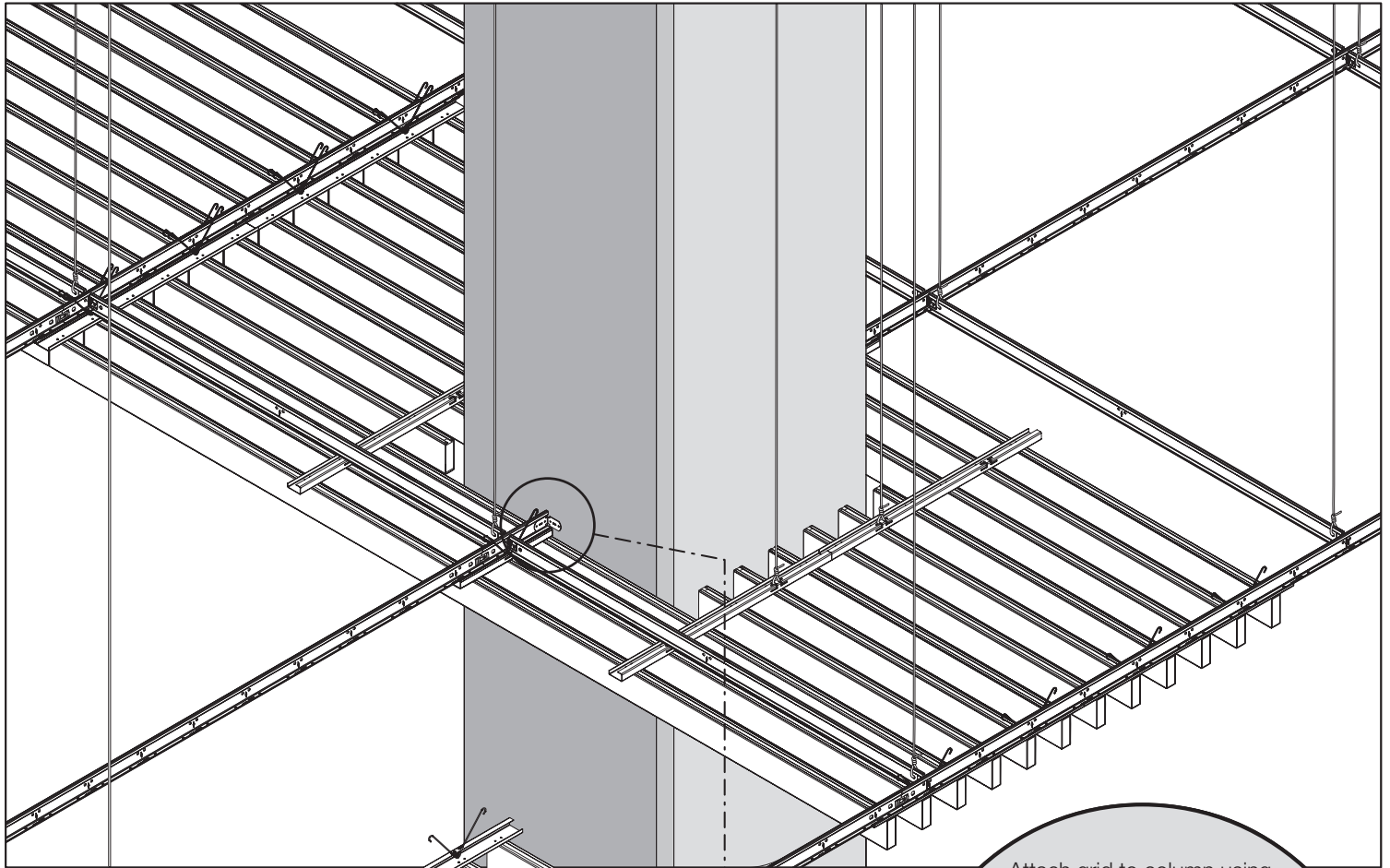

Attach grid to column using CL Clip as shown. Hardware type should be selected based on substrate.

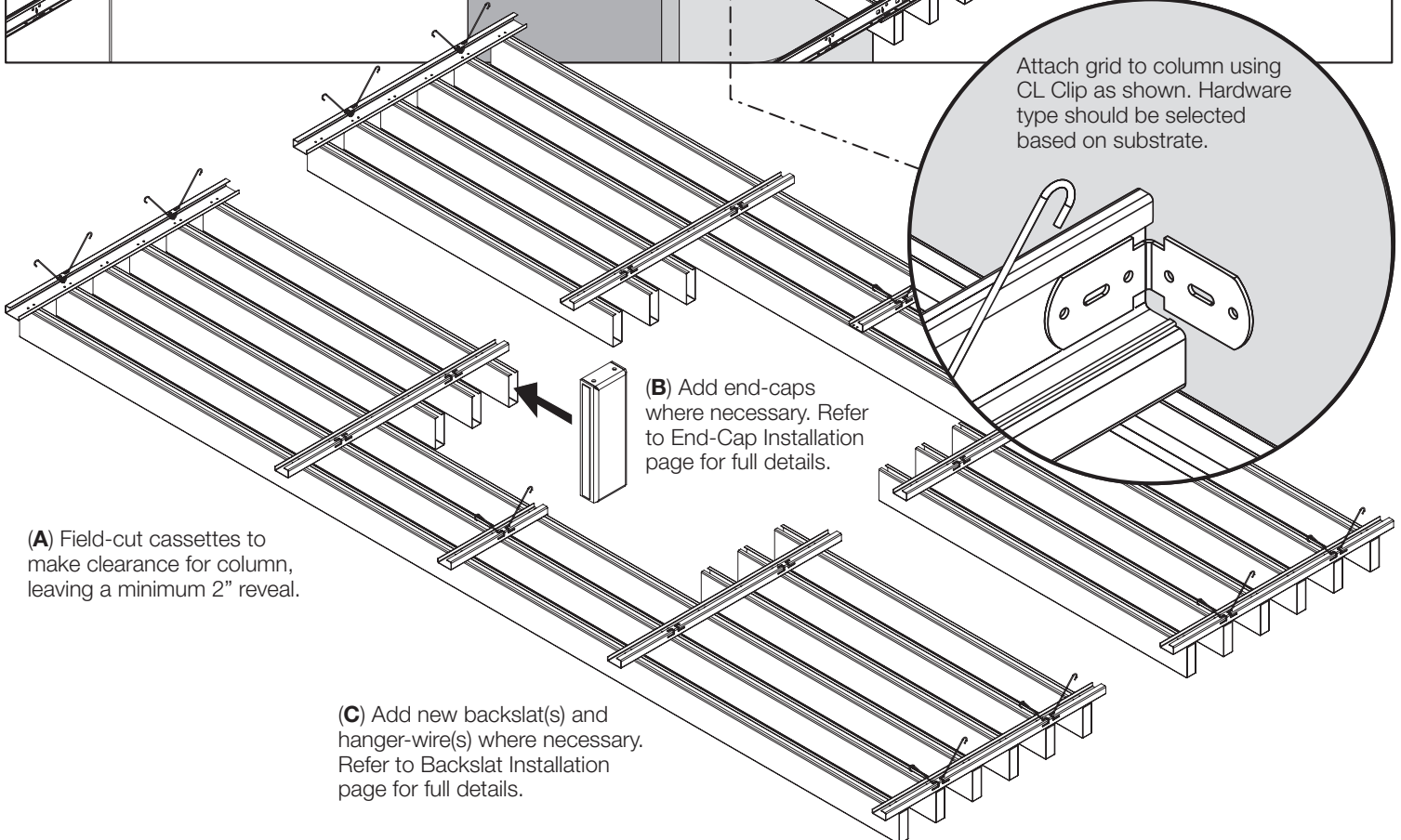

**(A)** Field-cut cassettes to make clearance for column, leaving a minimum 2" reveal.

**(B)** Add end-caps where necessary. Refer to End-Cap Installation page for full details.

**(C)** Add new backslat(s) and hanger-wire(s) where necessary. Refer to Backslat Installation page for full details.



# MEP Integration Lighting

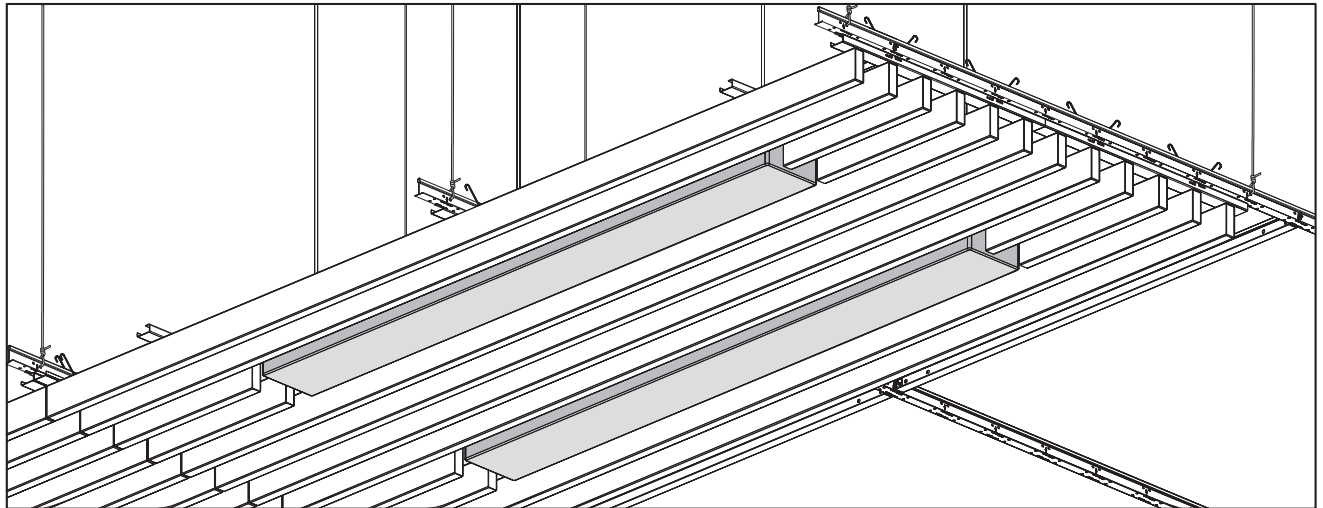
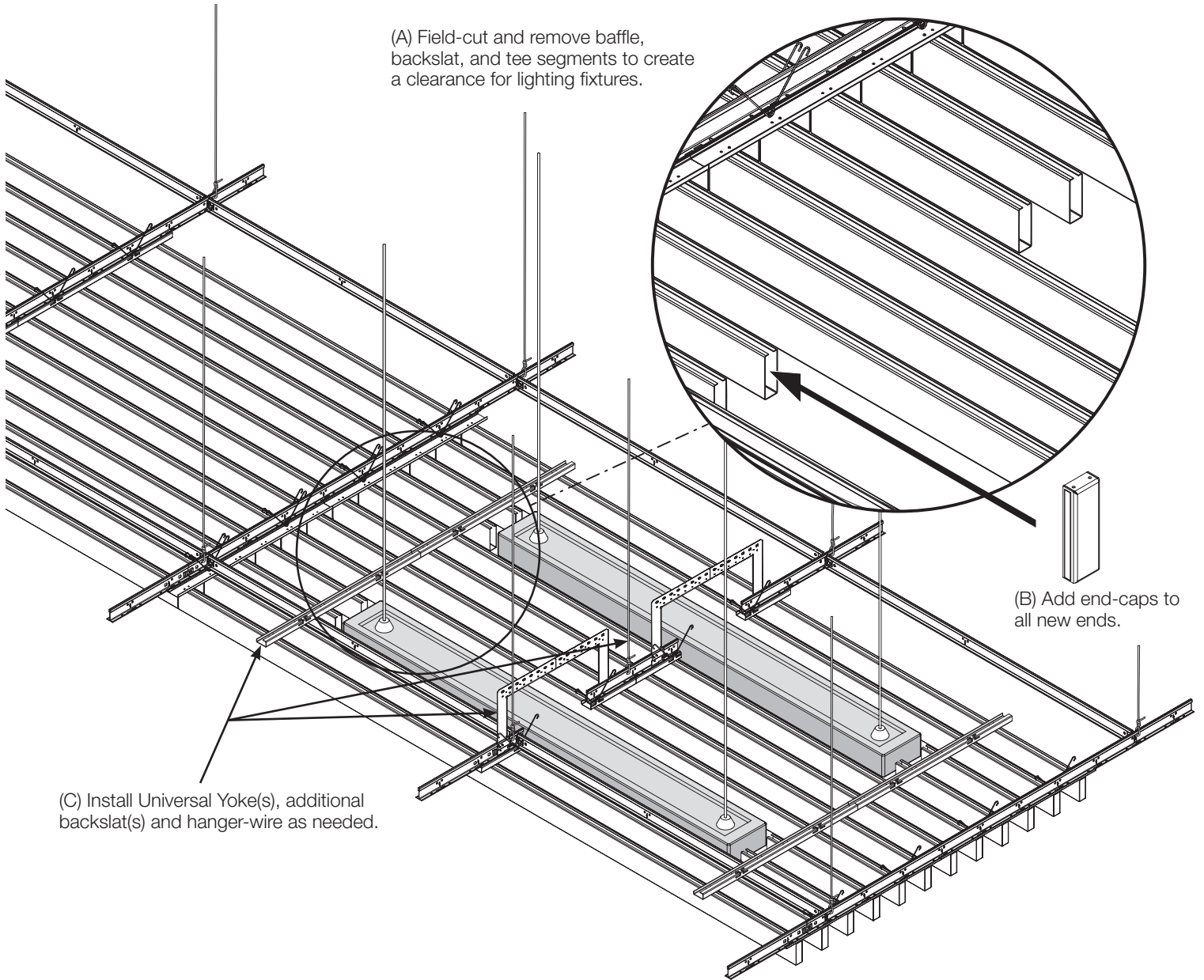

# MEP Integration Sprinklers

If BARZ system is NOT open 70% or greater, follow steps below:

(A) Field-cut and remove bar segments, backslat(s), and tees to create a clearance for Sprinklers.

((B) Add end-caps to all new ends.

(C) Add new backslat(s) and hanger-wire(s) where necessary.

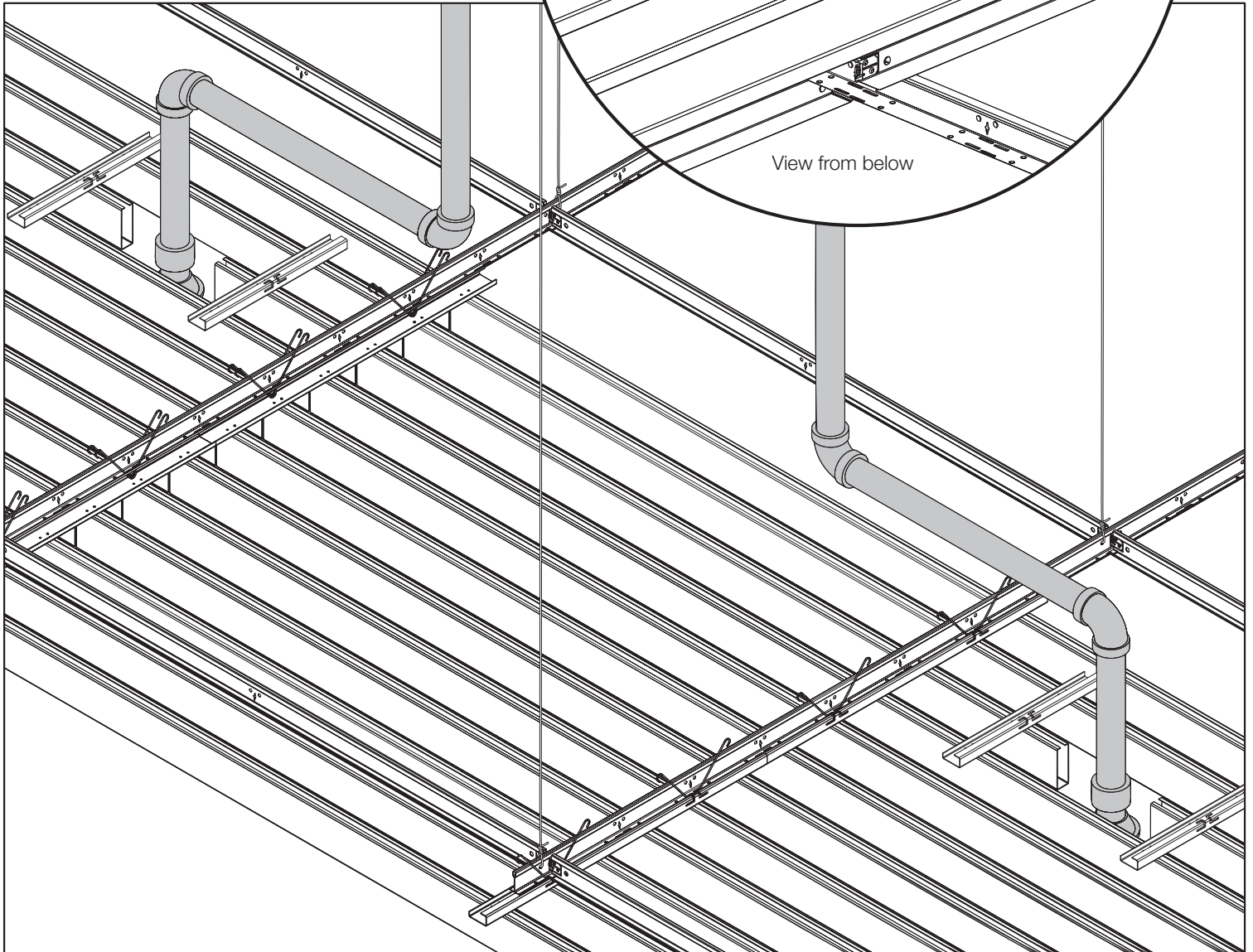
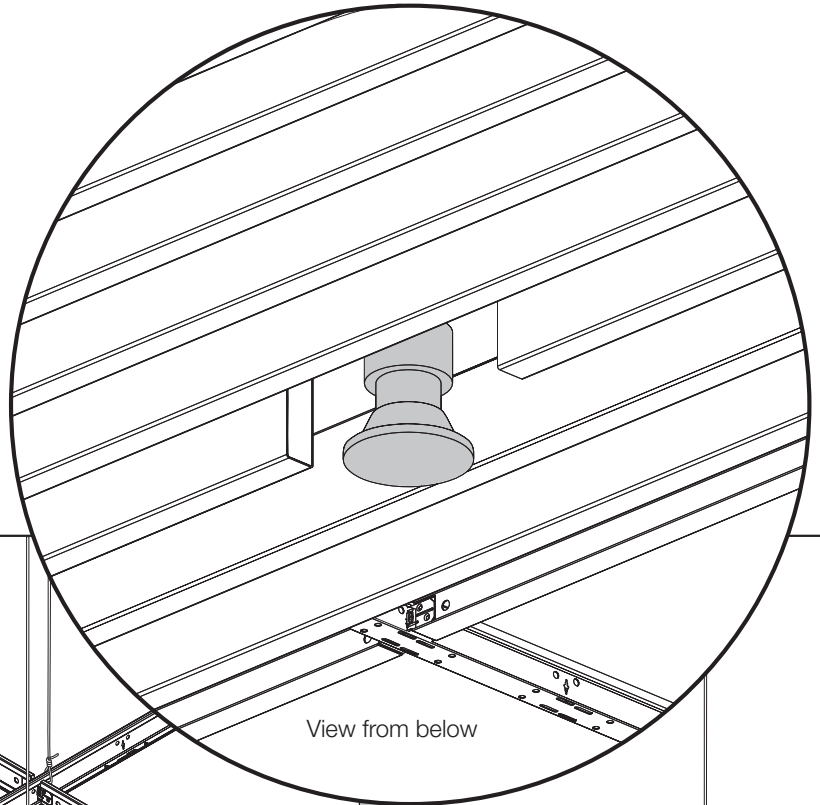



# MEP Integration HVAC

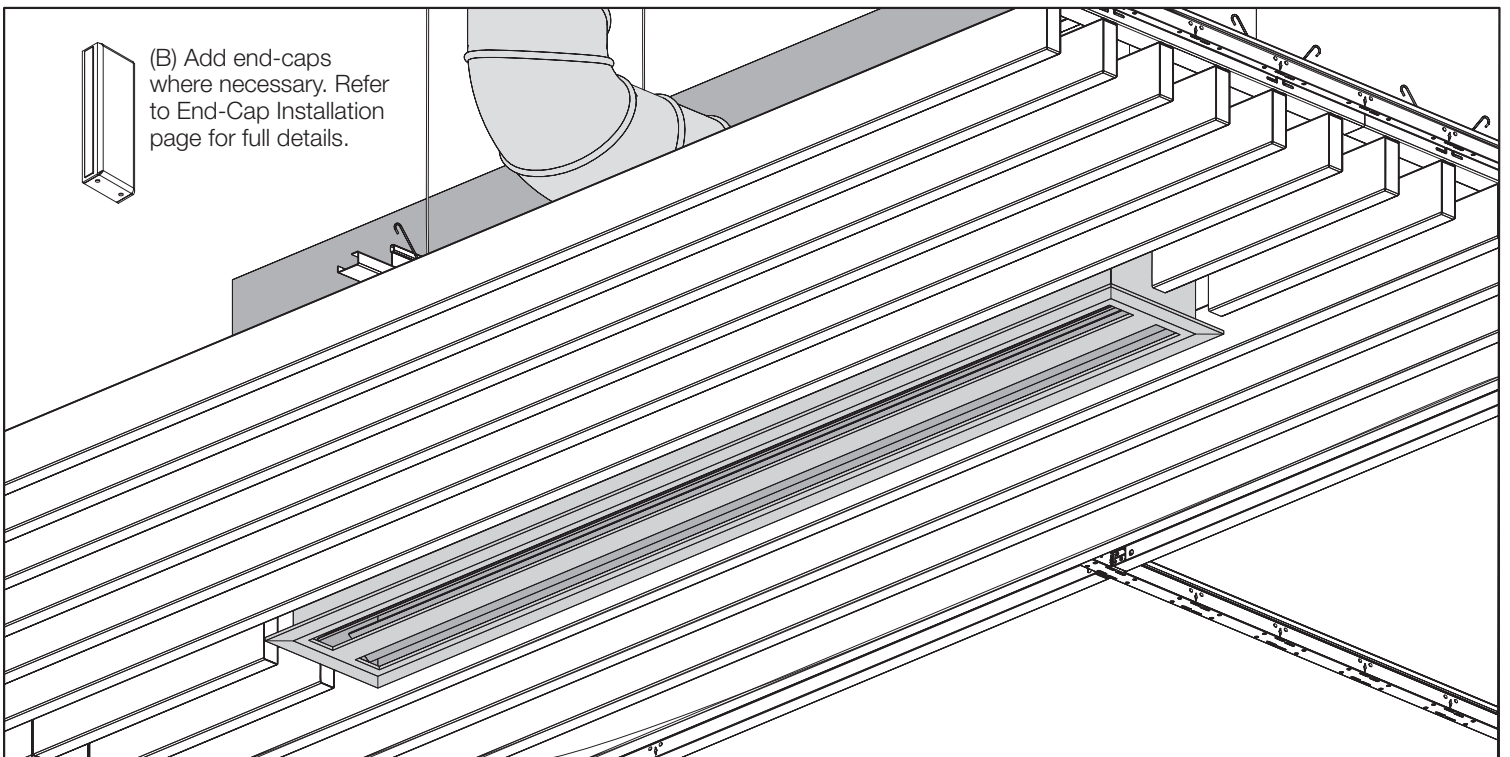
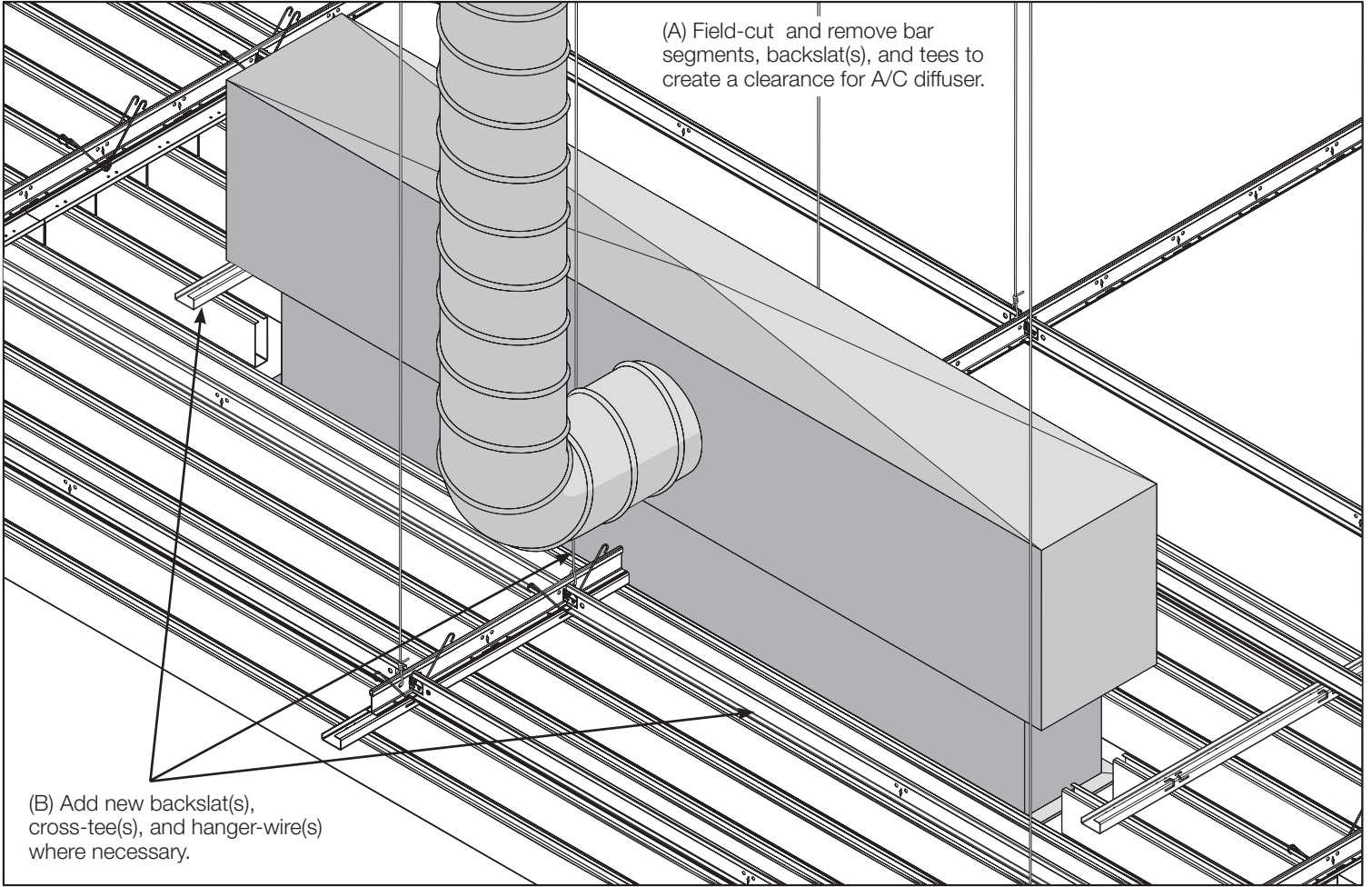

# Custom Installations

## General Wall Installation

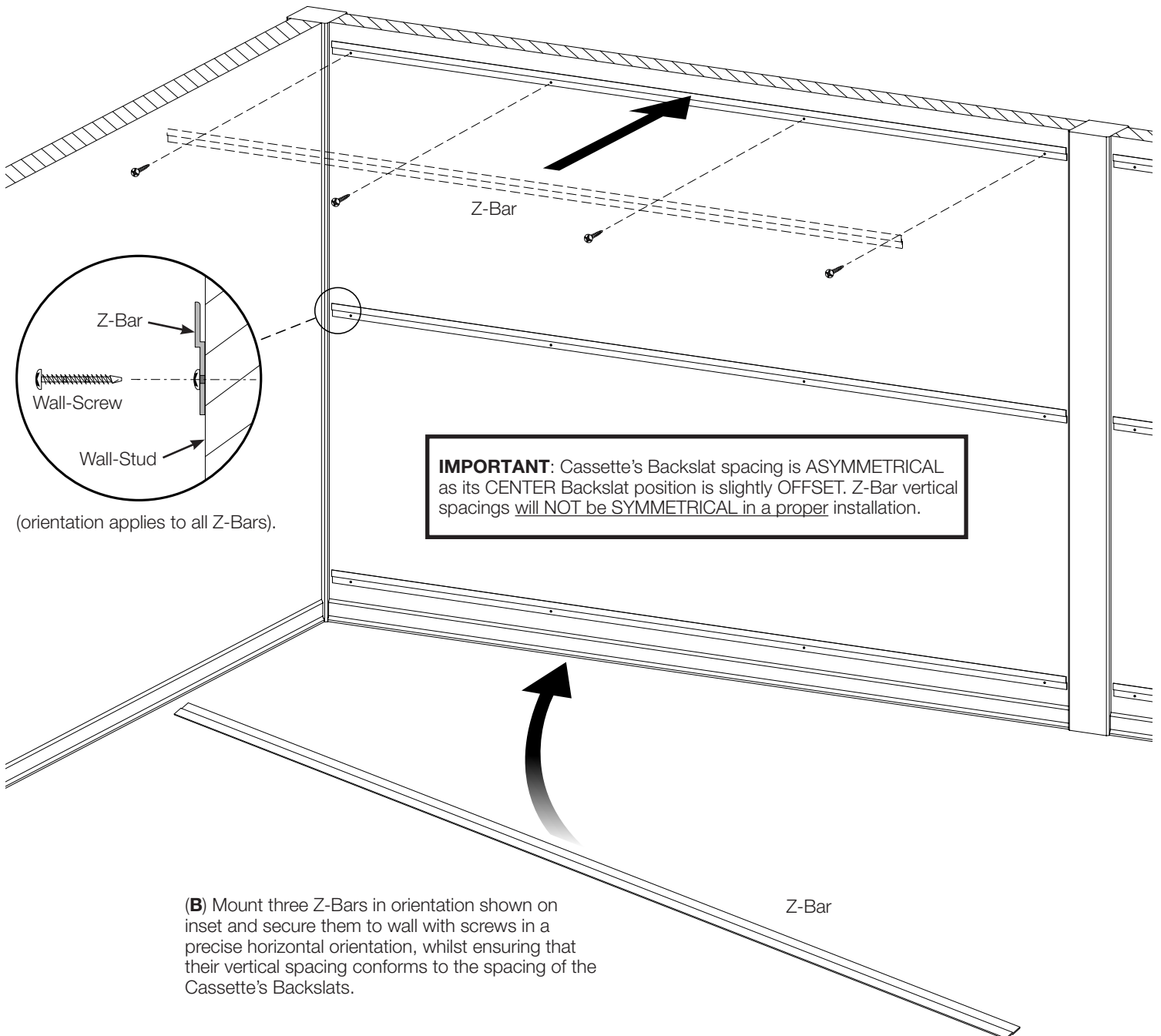
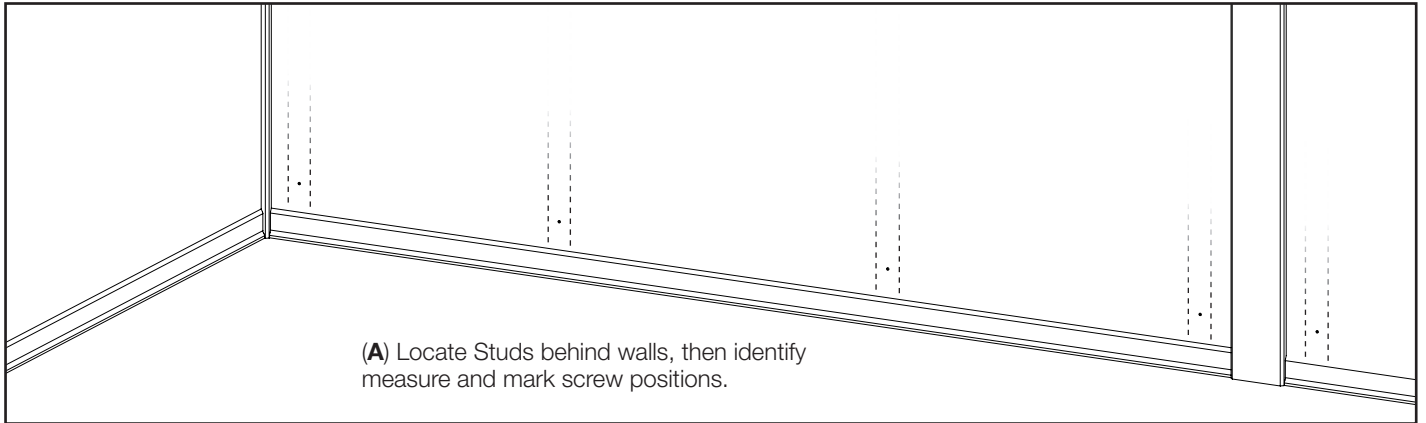

# Custom Installations

## General Wall Installation

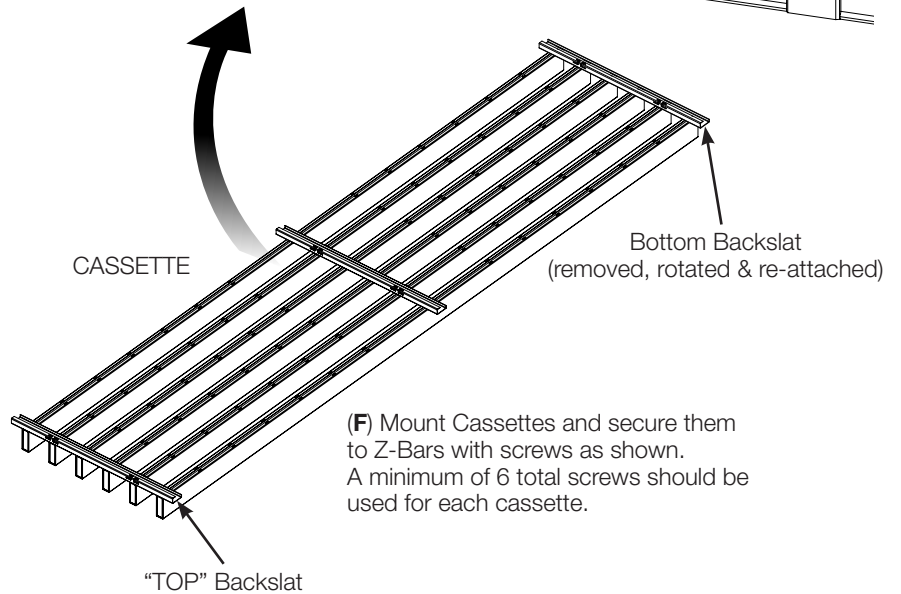
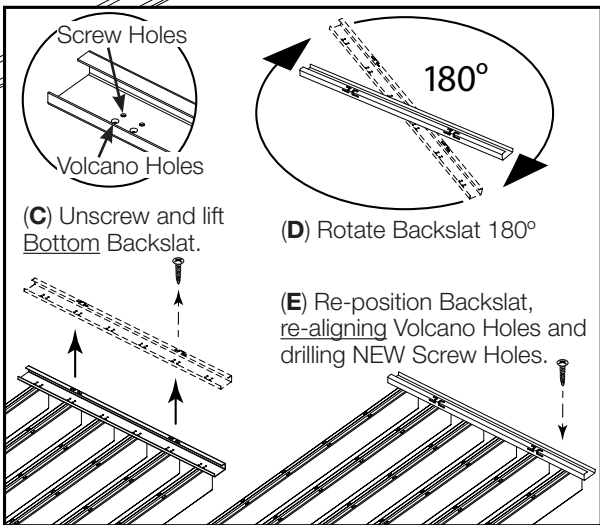
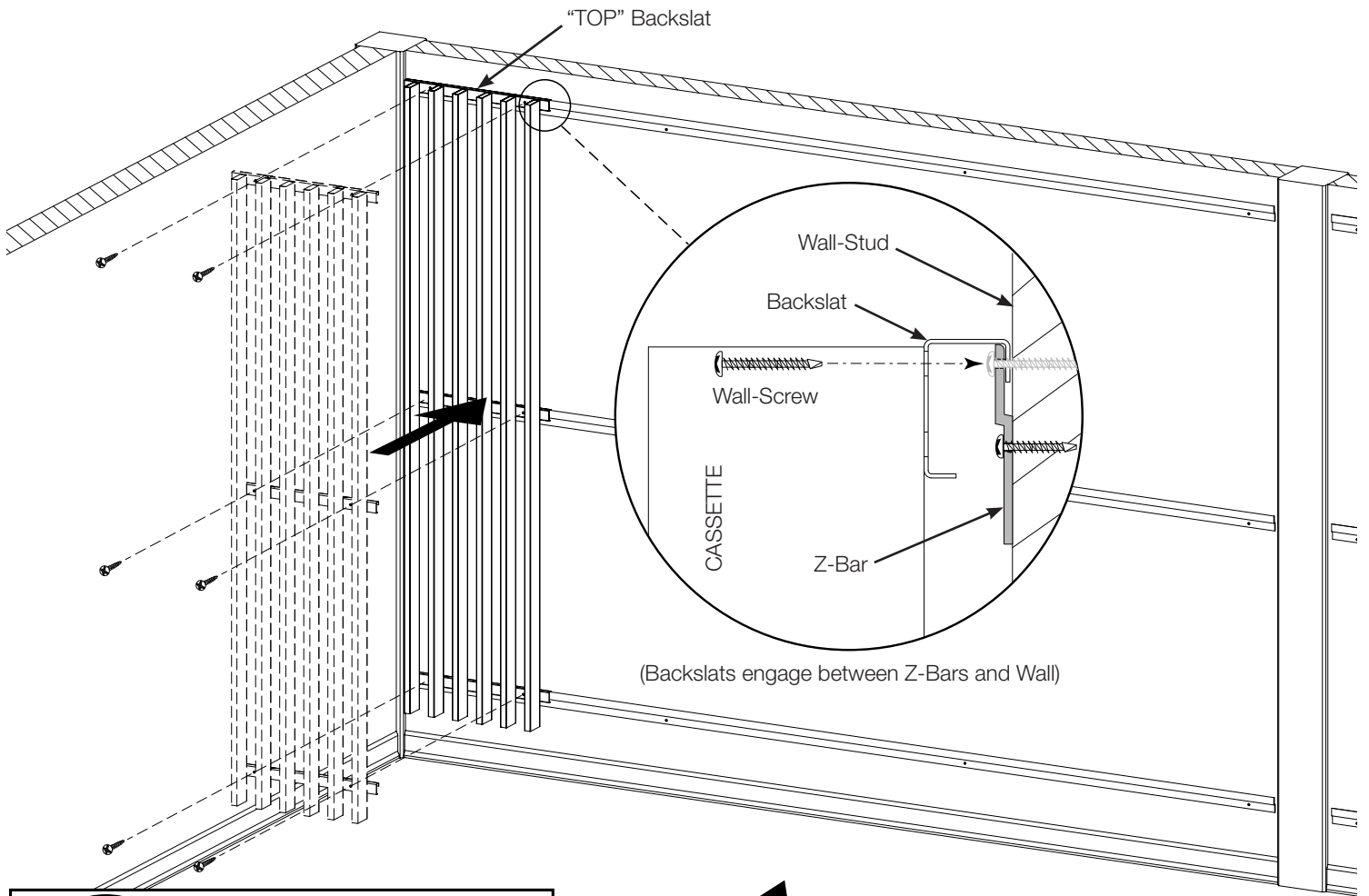

The Bottom Backslat is removed from each Cassette, then rotated and re-attached so that all 3 Backslats result in an identical orientation to allow for mounting onto Z-Bars.

# Custom Installations

## General Wall Installation

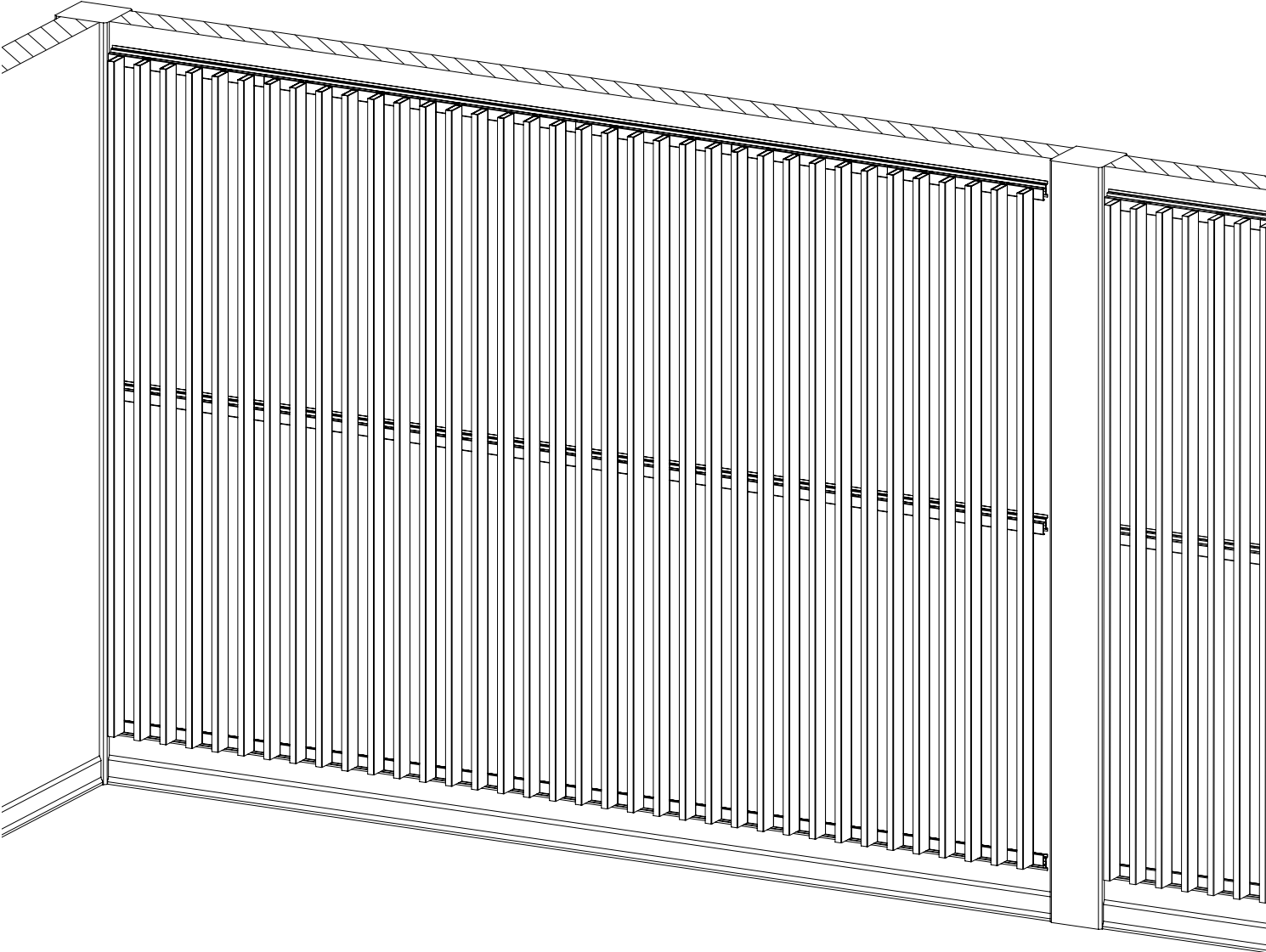

FULLY INSTALLED WALL APPLICATION

# Custom Installations

## Custom Cassette - Wall Installation

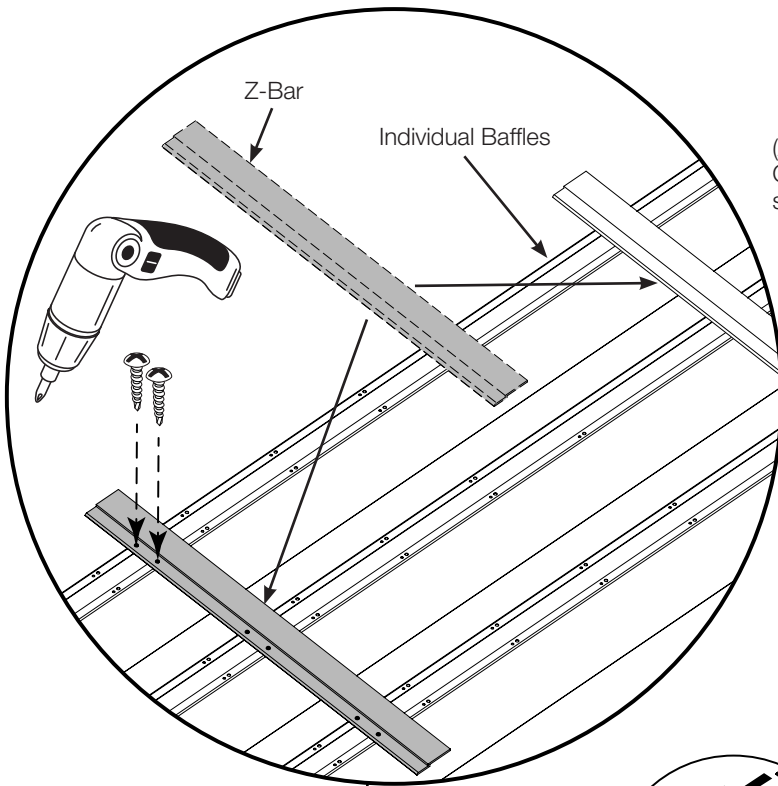

(A) Align individual Baffles, forming a group to build a custom Cassette. Next, attach three Z-Bars to Cassette group with screws, drilling new screw holes as necessary.

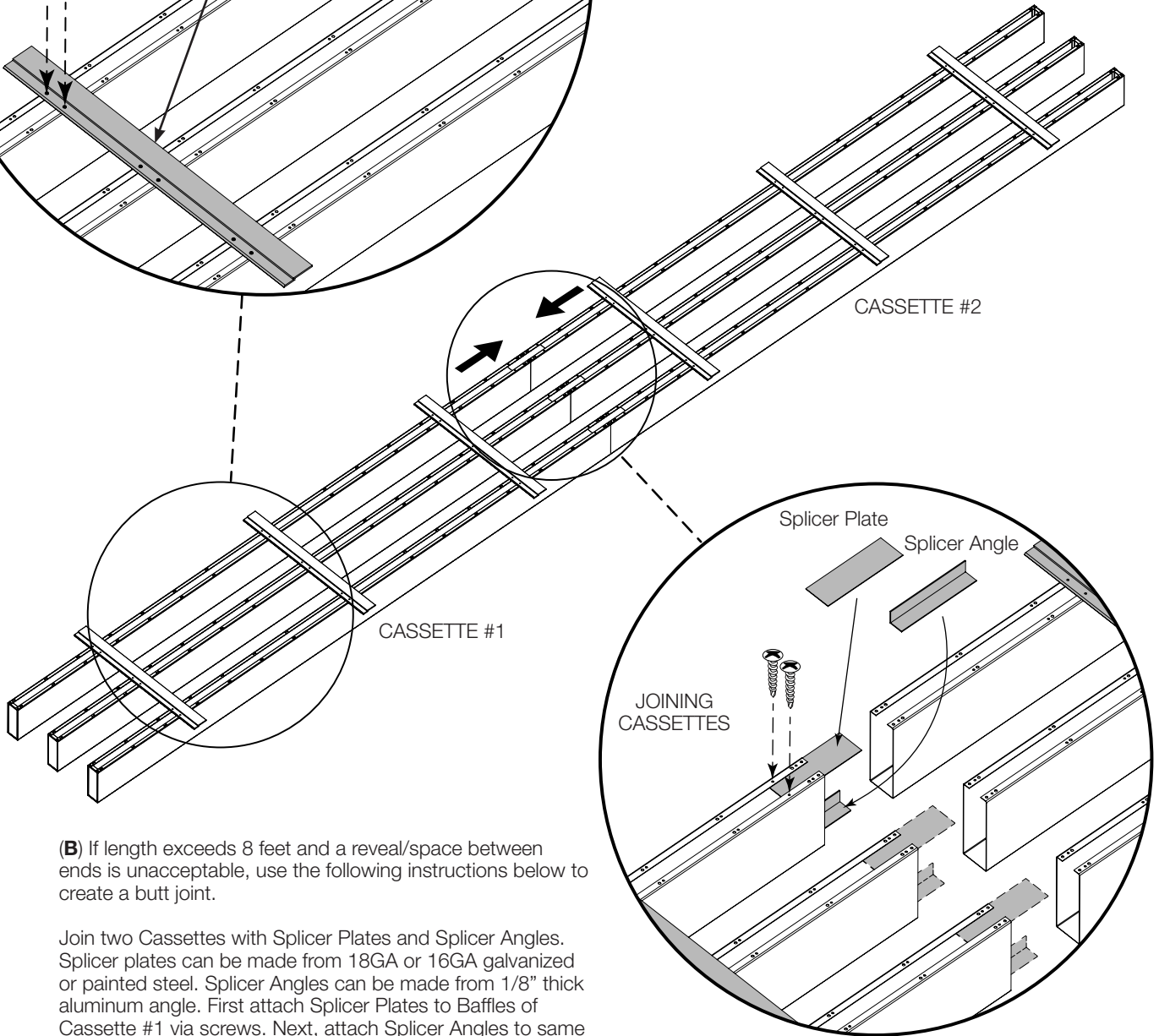

(B) If length exceeds 8 feet and a reveal/space between ends is unacceptable, use the following instructions below to create a butt joint.

Join two Cassettes with Splicer Plates and Splicer Angles. Splicer plates can be made from 18GA or 16GA galvanized or painted steel. Splicer Angles can be made from 1/8" thick aluminum angle. First attach Splicer Plates to Baffles of Cassette #1 via screws. Next, attach Splicer Angles to same Baffles via Double-Sided Tape. Lastly, align Cassette #2 by butting it up to Cassette #1 and finish attachment using same steps as above for both Splicer Plates and Angles.

# Custom Installations

## Custom Cassette - Wall Installation

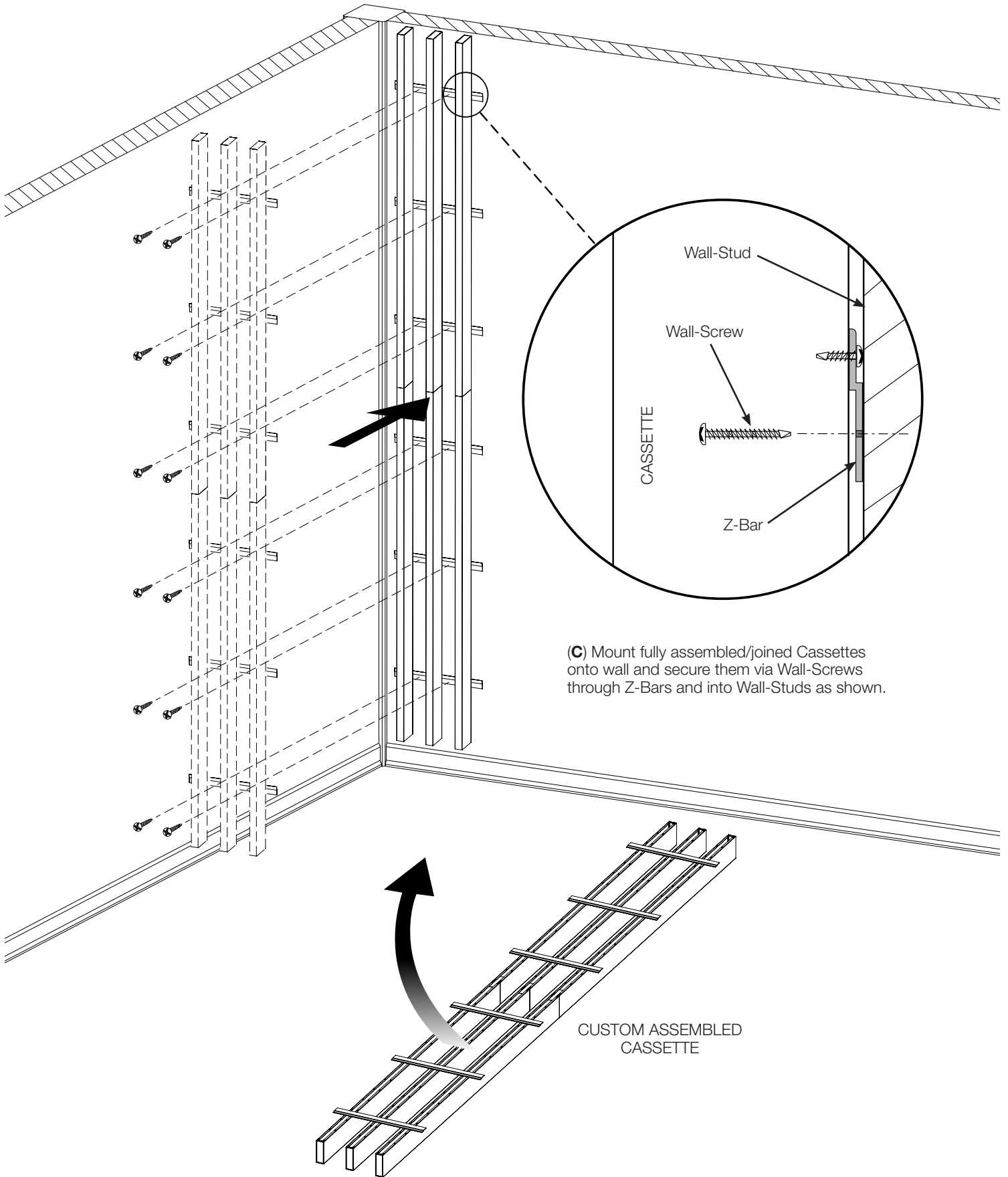



# Custom Installations

## Custom Cassette - Fully Installed Wall

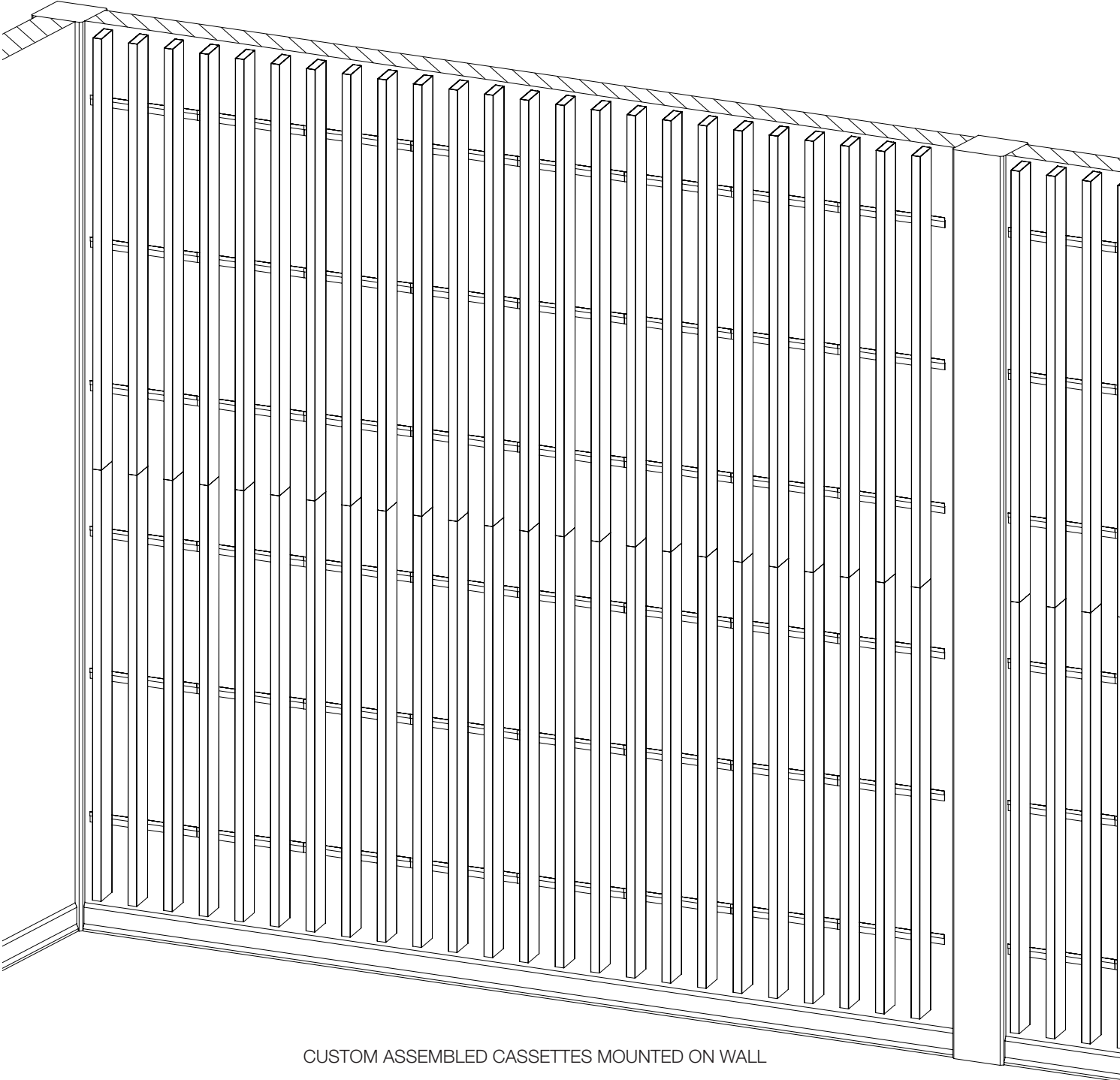

CUSTOM ASSEMBLED CASSETTES MOUNTED ON WALL

## Maintenance

### Adjust & Clean

- A.** Adjust ceiling components to provide a consistent finish and appearance in conformity with established tolerances and requirements.
  
- B.** Clean exposed surfaces of acoustical metal panel ceilings and walls. Comply with manufacturer's written instructions for cleaning and touch-up of minor finish damage.
  
- C.** Remove and replace work that cannot be successfully cleaned and repaired to permanently eliminate evidence of damage, including dented and bent units.

---

## Support

### Contacts

**Contact your sales rep for any additional support.**

## Notices

### SAFETY

Safety First! Follow good safety/industrial hygiene practices during installation. Wear appropriate personal protective equipment. Read MSDS and literature before specification and installation. Be cautious with exposed sharp edges when handling ceiling system components.

### INSTALLATION

Prior to installation, make sure your project complies with any seismic & non-seismic requirements. Must be installed in compliance with ASTM C636, ASTM E580, utilizing standard industry practices and adopting applicable code requirements. Alternative assemblies and installation methods may be utilized when approved by the authority having jurisdiction. USG Ceiling Plus recommends checking with the authority having jurisdiction prior to designing and installing a suspended ceiling system.

### LIMITATION

Some commercially acceptable color variation may occur between lots and between different size products of the same color.

### LIABILITY

We shall not be liable for any incidental and consequential damages, directly or indirectly sustained, nor for any loss caused by application of these goods not in accordance with current printed instructions of for other than the intended use. Our liability is expressly limited to replacement of defective goods. Any claim shall be deemed waived unless made in writing to us within thirty (30) days from date it was or reasonably should have been discovered.



