

USG
Interior
Panel &
Finishing
Solutions

SET YOUR DESIGN APART.
Drywall Suspension System

USG 
IT'S YOUR WORLD. BUILD IT.™

ONE SYSTEM, ENDLESS POSSIBILITIES

Drywall ceilings take a dramatic new shape with the USG Drywall Suspension System. This advanced system is pre-engineered to simplify planning and construction, ensuring that your design looks as good in real life as in your original concept.

- Offices
- Lobbies
- Conference Rooms
- Schools
- Retail
- Hospitality
- Entertainment



SYSTEM GUIDE

The USG Drywall Suspension System is specifically designed to construct curved, domed, and conventional flat drywall and plaster ceilings. The system assembles quickly and easily for faster installation as compared to traditional framing. System accessories and integrated straight and curved components offer easy transitions to vertical, horizontal or curved surfaces. Plus, the USG Drywall Suspension System has a lifetime limited warranty when used with USG Sheetrock® brand gypsum panels.

	Page	
Introduction	2	System Overview System Benefits
Components	4	System Components Component Hole Punching System Accessories
System Applications	10	Flat Drywall Ceilings USG Sheetrock® Brand Panels Information Transitions Boxed Soffits Curved Soffits Corridors Fascias Vaults Vaults and Valleys Domes Utility and Light Fixture Interfaces Fire-Rated Assemblies Information Exterior Application Information Seismic Information
Application Guide Specifications	45	Flat Drywall Ceilings Domes Curved Drywall Ceilings
For More Information		Technical Service 800 USG.4YOU Websites usg.com usgdesignstudio.com seismicceilings.com

SYSTEM OVERVIEW

Flat Ceilings

The USG Drywall Suspension System is engineered to replace traditional framing such as steel studs or cold-rolled channel and drywall furring channel for gypsum board ceiling installations. Main tees and cross tees snap together, which reduces wire ties. The system is suspended with 12-gauge hanger wire, which is easier to work with as compared to the 9-gauge required with cold-rolled channels.

Corridor Ceilings

The USG Drywall Suspension System—Wall-to-Wall is specifically designed for corridors and small rooms with crowded plenum spaces or with tight clearance to the deck above. The system can span up to 8' with no hanger wires or other intermediate support.

Curved Ceilings

The USG Drywall Suspension System is an excellent choice for curved ceilings with serpentine shapes, vaults or valleys. All components are custom bent at the factory, which results in precise, consistent curves and eliminates field bending. The system supports gypsum board and plaster, offering the ultimate in design freedom.

Domes

The USG Drywall Suspension System can be used to easily frame domes. Once the dome is designed, USG will engineer the framing system and custom bend all of the components at the factory. The pieces are then supplied as an easy-to-install kit that eliminates field bending and guesswork. USG Drywall Suspension domes can be finished with either gypsum board or plaster.

Online Estimating Tools

Estimating tools that generate a complete bill of materials for domes, vaults and valleys are available at usg.com.











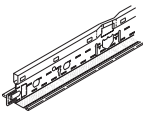
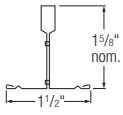

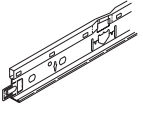
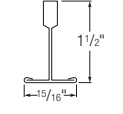

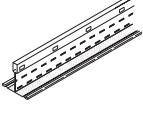
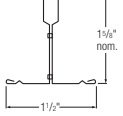
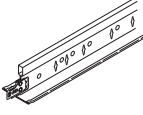
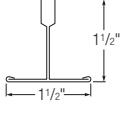

How it works: Go to usg.com > Resources > Online Tools and click on either “Dome Designer,” “Vault Estimator” or “Vaulted Dome Estimator.” Enter the dimension and other parameters when prompted, and the tools will generate a bill of materials, including all required accessories and general installation guidelines with hanger wire locations.

SYSTEM BENEFITS

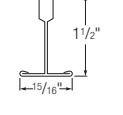
The USG Drywall Suspension System offers distinct advantages over traditional drywall ceiling framing systems.

Main tees	Heavy-duty, fire-rated systems for all flat ceiling applications increase flexibility; available in 1-1/2" and 15/16" face width for flat ceilings, and 1-1/2" face width for curved ceilings.
Main-tee splices	Integral reversible end detail for flat ceilings with fast, locked-in connections.
Cross tees	Quick-Release™ clip for faster installation; eliminates wire tying; removes without tools; speeds rework.
Knurled-face components	Easier screw penetration on all components.
Galvanized steel	G40 available for most environments, G90 for more severe conditions.
System flexibility	Easily transitions from soffits, flat and curved surfaces; also transitions to acoustical ceilings.
UL designs	More than 60 UL-listed fire-resistant designs are available, including 30 with DGLW625 cross tees.
Limited lifetime system warranty	Lifetime limited warranty (30-year; see SC2102) when used with USG Sheetrock® Brand gypsum panels.
Standard 10-year warranty	10-year on suspension system.
Accepts Type F or G fixtures	Main tees and cross tees are punched to easily frame openings for both Type G and Type F light fixtures.
12-gauge wire	Easier to work with than the 9-gauge wire required with traditional framing systems.

SYSTEM COMPONENTS

							Rated Load	
System Components		ASTM Class	Length	Height	Item No.	Class	4' Hanger Spacing	
	DGLW 	Heavy Duty	12'	1.617"	DGLW26		16.0 lbs./LF	
		Heavy Duty	6' to 14'	1.617"	DGLW26s		16.0 lbs./LF	
	DGL 	Heavy Duty	12'	1-1/2"	DGL26		16.0 lbs./LF	
		Heavy Duty	7' to 14'	1-1/2"	DGL26s		16.0 lbs./LF	
	DGW 	Heavy Duty	6' to 14', Custom	1.617"	DGW26s	Class A	16.0 lbs./LF	
	DGLW 	—	2'	1-1/2"	DGLW224		—	
		—	26"	1-1/2"	DGLW2624		—	
		—	4'	1-1/2"	DGLW424		—	
		—	50"	1-1/2"	DGLW50		—	
		—	6'	1-1/2"	DGLW624		—	
	DGL 	—	2'	1-1/2"	DGL224		—	
		—	4'	1-1/2"	DGL424		—	
		—	8'	1-1/2"	DG824	Class A	—	
		—	4'	7/8"	DGCL4		7.4 lbs./LF	
		Moldings		—	12'	1"	DGWM24	—
	—	12'	1-5/8"	DGCM27¹	—	—		

¹The DGCM27 molding is for use with DGLW tees only.

COMPONENT HOLE PUNCHING

Flat Drywall Ceilings

Cross Tees

DGLW224
DGLW2624
DGL224
DGL324
DG824

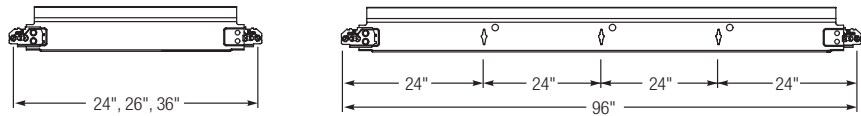

DGL424

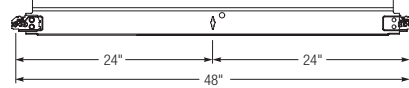

DGLW424

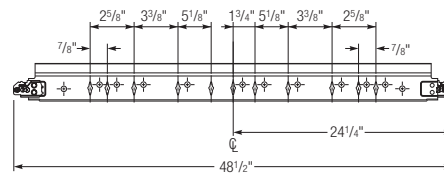

DGLW624

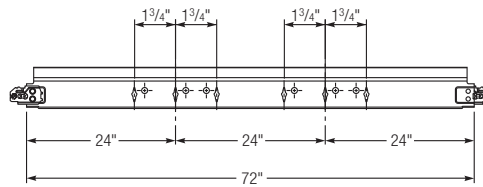

DGLW50

Specially designed for framing Type F light fixtures, these cross tees require no field-cutting and provide more options for fixture placement, including centered between main tees.

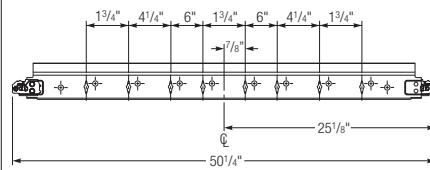

Straight Main Tees

DGLW26

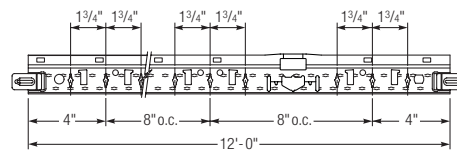

DGL26

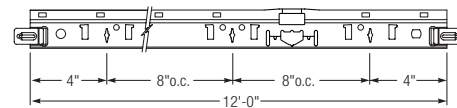

DGW26S

Wall-to-Wall System

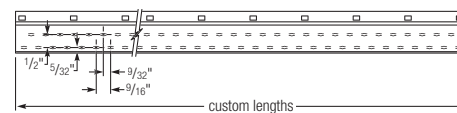

SYSTEM COMPONENTS

Curved Drywall Ceilings

Custom Curves

All curved main tees are custom-made to meet design requirements and to dramatically simplify the process of building curved drywall ceilings. Whether designing barrel vaults, domes, archways, valleys, waves or serpentes, the curved grid allows for smooth transitions to flat ceilings, soffits or acoustical ceiling suspension systems. Below, in the item number nomenclature, "xxx" is a placeholder for a custom radius in inches. For example, DGW6VT360 has a radius of 360 inches.

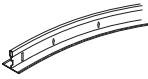
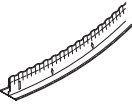
System Components		Radius	Arc Length	Height	Item No.	Class	Rated Load	
							2' Hanger Spacing	4' Hanger
	Vault	31"-44"	6'	1-1/2"	DGW6VTxxx	Class A	—	16.0 lbs./LF
		45"-60"	8'	1-1/2"	DGW8VTxxx	Class A	—	16.0 lbs./LF
		61"-239"	10'	1-1/2"	DGW10VTxxx	Class A	—	16.0 lbs./LF
		240"+	12'	1-1/2"	DGW12VTxxx	Class A	—	16.0 lbs./LF
	Valley ²	31"-44"	6'	1-1/2"	DGW6VYxxx	Class A	16.0 lbs./LF	—
		45"-60"	8'	1-1/2"	DGW8VYxxx	Class A	16.0 lbs./LF	—
		61"-239"	10'	1-1/2"	DGW10VYxxx	Class A	16.0 lbs./LF	—

² As tested per independent testing agency, valleys require hanger wire spacing of 2' on center.

Curved Main Tees

Valleys

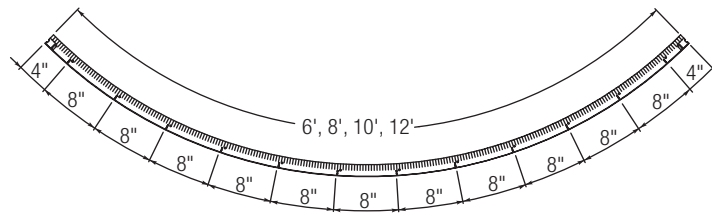



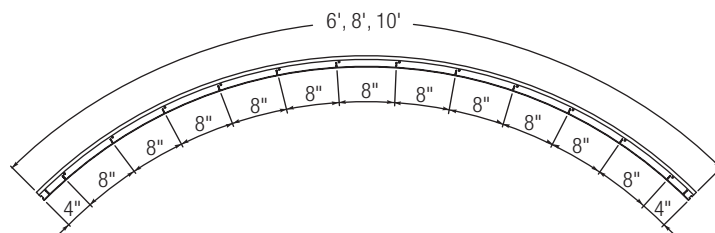



Vaults

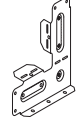
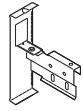

Note: Length depends on radius. See chart on page 7.

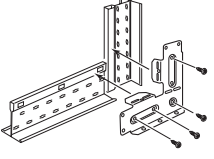
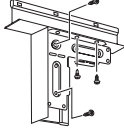
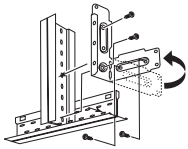
SYSTEM ACCESSORIES

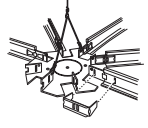
These are the accessories for the USG Drywall Suspension System. Many of the accessories are multifunctional. Transitions from soffits, curved or flat surfaces can be easier with the use of these accessories.

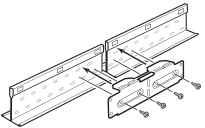
Accessories	DGSC-180—Splice Clip	DGTC-90—Transition Clip	DGC4, DGC6, DGC8—Compasso™ Drywall Clip
			DGWC—Wall Attachment Clip
	DGSP-180—Splice Plate	DGHUB—Dome Hub	Splice Plate DGSP-180 
Transition Clip DGTC-90	Application A	The transition clip securely joins two intersecting grid components, regardless of face width, at a 90° angle. Bend down tabs secure the clip to the grid. Screws are required to provide a structural connection.	 
Application B Field Modified	Application B Field Modified	The transition clip has a slotted bend line to facilitate connecting grid members that are not in a line.	
Dome Hub DGHUB 		The dome hub serves as a base from which primary spokes are connected with splice plates.	
Splice Clip DGSC-180 	Application A	The primary purpose of the splice clip is to join two in-line main tees field-cut to length, either straight or curved.	

SYSTEM ACCESSORIES

Splice Clip DGSC-180

Application B

Another common use of the splice clip is joining two grid tees that are intersecting off a module, such as a utility opening. The link joining the bend-down tabs on the clip is cut, allowing it to be folded on the slotted bend line.

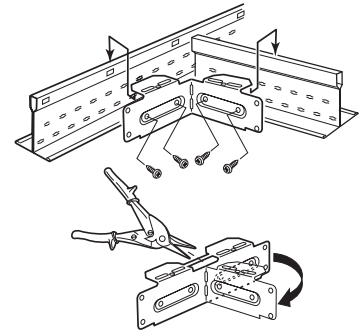

Application C Field Modified

The splice clip also is used to connect two main tees that are in line but intersecting at an angle, such as a flat ceiling transitioning to a vault. This application requires not only cutting the connecting link but also separating the clip at the slotted bend line. The two halves are then rejoined with a pop-rivet or screw through the holes on the clip ends. Use top hole in clip for straight to vaults. Use bottom hole in clip for straight to valleys.

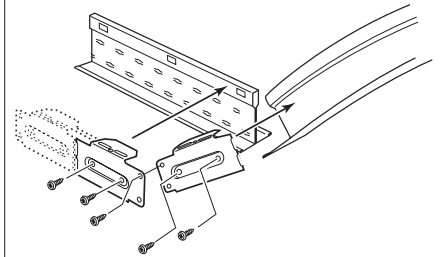

Wall Attachment Clip DGWC

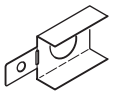

The wall attachment clip acts as a spacer between the wall surface and the web of the grid when curved main tees need to be secured to the wall at a wall stud. This prevents twisting of the grid and insures a sound installation.

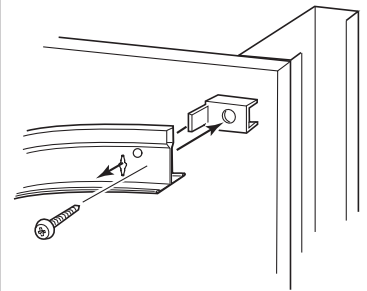

Compässo™ Clips

DGC4
DGC6
DGC8

DCC10
DGC12

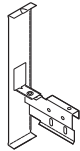
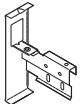

Compässo suspension trim clips are available to match 4", 6", 8", 10" and 12" Compässo trim. These clips are adjustable for both 1/2" and 5/8" drywall. The two portions of the clip are pivoted to accommodate Compässo trim at any angle in relation to the grid.

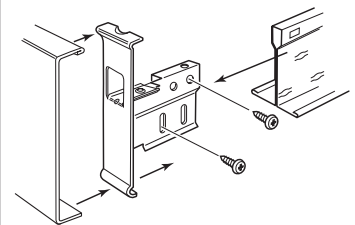

FLAT DRYWALL CEILINGS

Framing gypsum board ceilings with the USG Drywall Suspension System is faster compared to using cold-rolled channel and hat-channel. Pre-engineered components are designed for maximum installation speed, including main tees with cross-tee punchings to facilitate framing for Type F and Type G light fixtures.

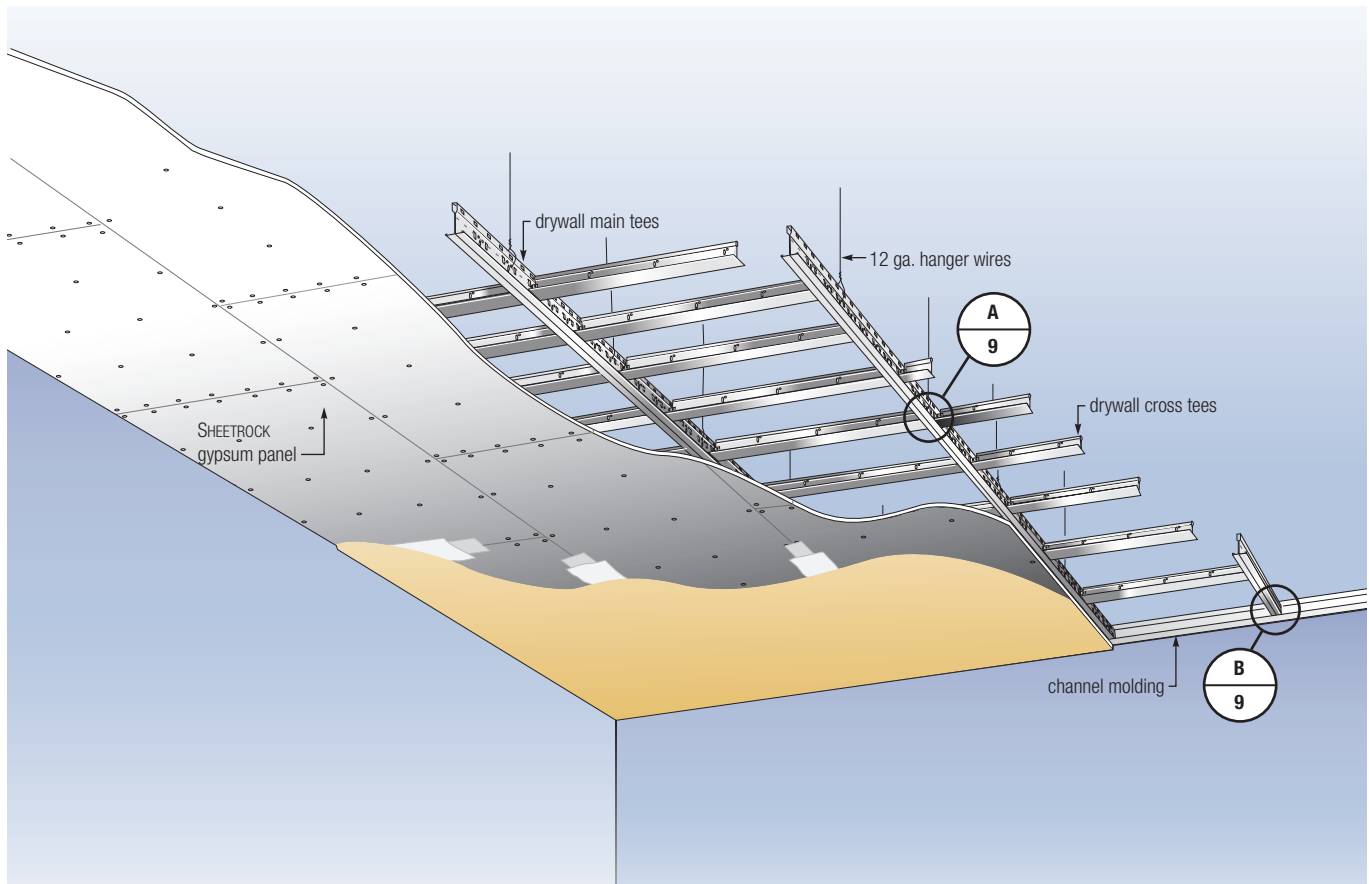

- Ceiling loads for various main-tee and cross-tee spacing are provided in the table on page 12.
- See pages 39–42 for special requirements for fire-rated assemblies.

Note: These renderings and details are provided for illustrative purposes only and are not a substitute for certified architectural and engineering drawings, nor do they necessarily reflect national and local building code requirements. For additional information, see specifications on page 47 or call Technical Service at 800 USG.4YOU.

FLAT DRYWALL CEILINGS

Layout with 6' cross tees and main tees 6' OC

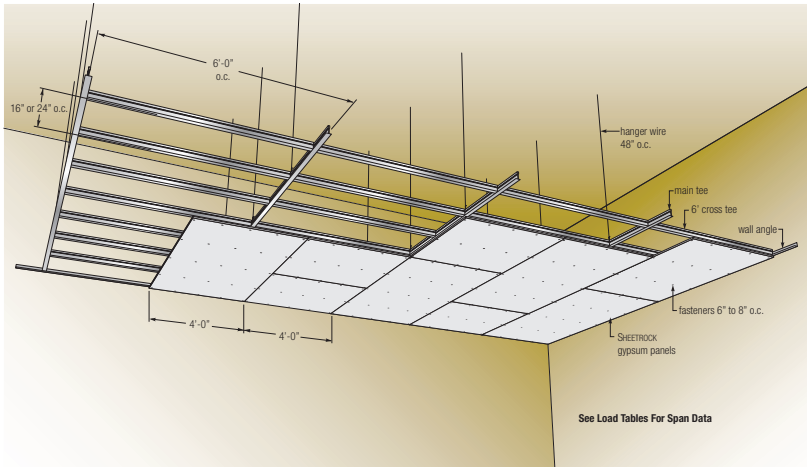

Flat ceiling with 6' cross tees and main tees 6' OC. Requires 1/3 fewer main tees and hanger wires.

Cross tee/main tee intersection

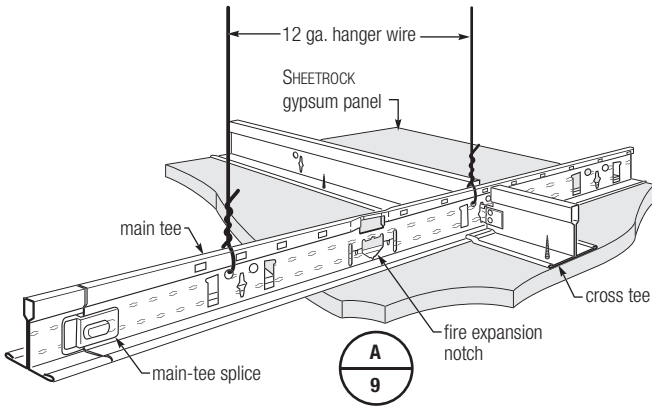

Cross-channel detail

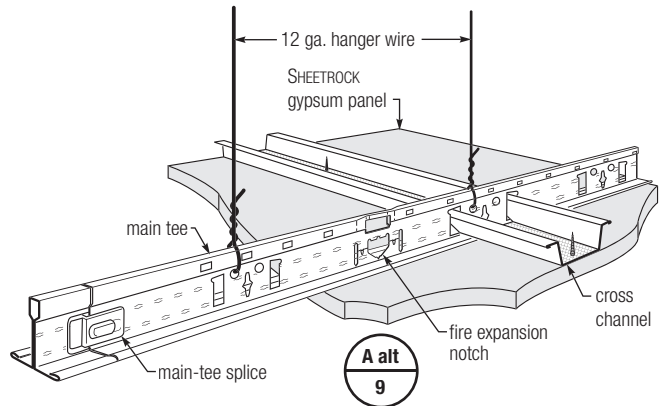

Perimeter detail—channel molding

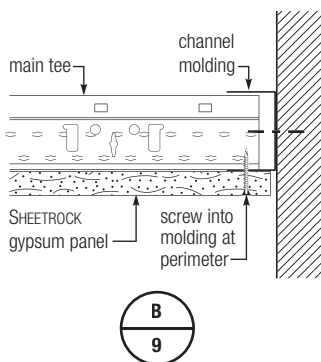

Perimeter detail—angle molding

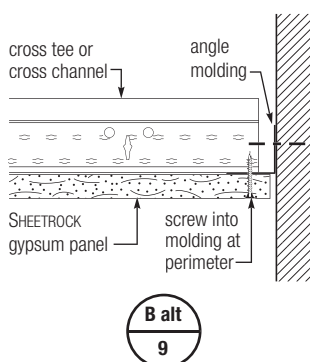

USG SHEETROCK® BRAND PANELS INFORMATION

A lifetime limited (30-year) warranty on the USG Drywall Suspension System is offered when USG Sheetrock® Brand (or other USG) Panels are used. The USG Drywall Suspension System is engineered to accept 1/4", 3/8", 1/2" and 5/8" gypsum panels for flat and curved ceiling applications. The system can be used with veneer plaster and conventional lath and plaster ceilings as well.

Panel Selector Guide

Product	Weight lbs-ft ²	Max Cross Tee Spacing ³				Load on Wire, lbs
		Perpendicular ¹	Parallel ¹	Hanger-Wire Spacing		
Interior Panels	1/4" USG Sheetrock® Brand Panels (regular and flexible) ²	2.4 (double layer)	8" to 16"	N/A	48"	43.2
	3/8" USG Sheetrock® Brand Panels	1.4	16"	N/A	48"	22.4
	1/2" USG Sheetrock® Brand Panels (standard weight)	1.5	24"	16"	48"	28.8
	1/2" USG Sheetrock® Brand UltraLight Panels	1.3	24"	24"	48"	25.6
	1/2" USG Sheetrock® Brand Firecode C Panels	2	24"	16"	48"	36.8
	5/8" USG Sheetrock® Brand Firecode X Panels	2.3	24"	24"	48"	41.6
	5/8" USG Sheetrock® Brand Firecode C Panels	2.5	24"	24"	48"	44.8
Moisture and Mold Resistant	1/2" USG Sheetrock® Brand Mold Tough Panels	1.6	24"	16"	48"	30.4
	1/2" USG Sheetrock® Brand Mold Tough Firecode C Panels	2	24"	16"	48"	36.8
	5/8" USG Sheetrock® Brand Mold Tough Firecode X Panels	2.3	24"	16"	48"	41.6
	5/8" USG Sheetrock® Brand Mold Tough Firecode C Panels	2.5	24"	16"	48"	44.8
	5/8" USG Sheetrock® Brand Glass Mat Panels Mold Tough Firecode X	2.4	16"	N/A	48"	43.2
Exterior Panels⁴	1/2" USG Sheetrock® Brand Exterior Ceiling Panels	1.6	24"	16"	48" ^{4a}	30.4
	5/8" USG Sheetrock® Brand Firecode X Exterior Ceiling Panels	2.4	24"	16"	48" ^{4a}	43.2
	5/8" USG Sheetrock® Brand Firecode C Exterior Ceiling Panels	2.5	24"	16"	48" ^{4a}	44.8
	1/2" USG Securock® Brand Glass Mat Sheathing Panels	2	16"	N/A	48" ^{4a}	36.8
	5/8" USG Securock® Brand Firecode X Glass Mat Sheathing Panels	2.7	16"	N/A	48" ^{4a}	48
Plaster Base Panels	1/2" USG Imperial® Brand Gypsum Base	1.8	16"	16"	48"	33.6
	5/8" USG Imperial® Brand Gypsum Base Firecode X	2.3	16"	16"	48"	41.6
	5/8" USG Imperial® Brand Gypsum Base Firecode C	2.5	16"	16"	48"	44.8

¹ Refers to panel installation orientation, factory-tapered edges parallel or perpendicular to cross tees.

² 1/4" USG Sheetrock® Brand Panels require double-layer installation.

³ Fire-rated UL Designs may supersede cross-tee spacing listed.

⁴ Exterior ceilings designed for wind uplift resistance may supersede cross-tee and hanger-wire spacing listed.

Ceiling Membrane Load Values

Deflection Criteria-L/240

Hanger-Wire Spacing, in-OC	24				36				48				
	24	36	48	72	24	36	48	72	24	36	48	72	
Main-Tee Spacing, in-OC													
Membrane Load, lbs-ft²	DGL26 Main Tee-15/16" face	64.5	43.0	32.3	N/A	28.5	19.0	14.3	N/A	12.0	8.0	6.0	4.0
	DGLW26 Main Tee-1-1/2" face	64.5	43.0	32.3	N/A	28.5	19.0	14.3	N/A	12.0	8.0	6.0	4.0

Deflection Criteria-L/360

Hanger-Wire Spacing, in-OC	24				36				48				
	24	26	48	72	24	36	48	72	24	36	48	72	
Main-Tee Spacing, in-OC													
Membrane Load, lbs-ft²	DGL26 Main Tee-15/16" face	43.0	28.7	21.5	N/A	19.0	12.7	9.5	N/A	8.0	5.3	4.0	2.7
	DGLW26 Main Tee-1-1/2" face	43.0	28.7	21.5	N/A	19.0	12.7	9.5	N/A	8.0	5.3	4.0	2.7

USG SHEETROCK® BRAND PANELS INFORMATION

Expansion Joints

At building movement and expansion joints, provide a separation in the suspension system and install back-to-back main tees to allow for building movement, expansion and contraction in large ceiling areas.

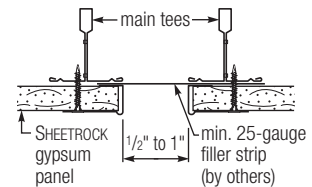

Control Joints

Control joints are used to control stress caused by expansion and contraction across the control joint in large ceiling expanses in both drywall and veneer plaster systems. Use control joint 093, which provides a 3/32" groove for drywall or veneer plaster for ceiling areas that exceed 50' (2500 sq. ft.) with perimeter relief and 30' (900 sq. ft.) without perimeter relief. For fire-rated ceilings, control joints shall not occur within 12" of the fire-expansion notch. Do not separate suspension: Use continuous single main tees.

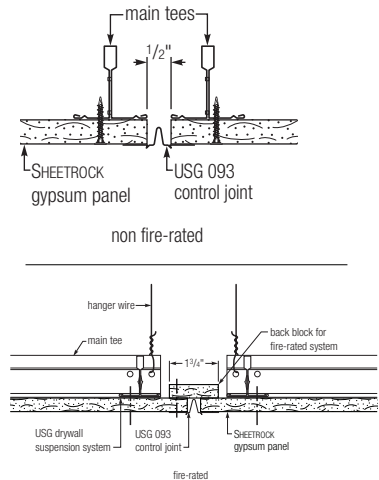

Special Note

Location of control and expansion joints is the responsibility of the design professional. Gypsum panel surfaces should be isolated with control joints, caulk or other means where:

1. Ceiling or soffit abuts a structural element, column, partition or other vertical penetration.
2. Construction changes within a plane of the ceiling.
3. Ceiling dimensions exceed 50' in either direction (2500 sq. ft.) with perimeter relief or 30' (900 sq. ft.) without relief.
4. Soffit exceeds 30' in either direction.
5. Wings of "L"- "U"- and "T"-shaped ceiling areas are joined.

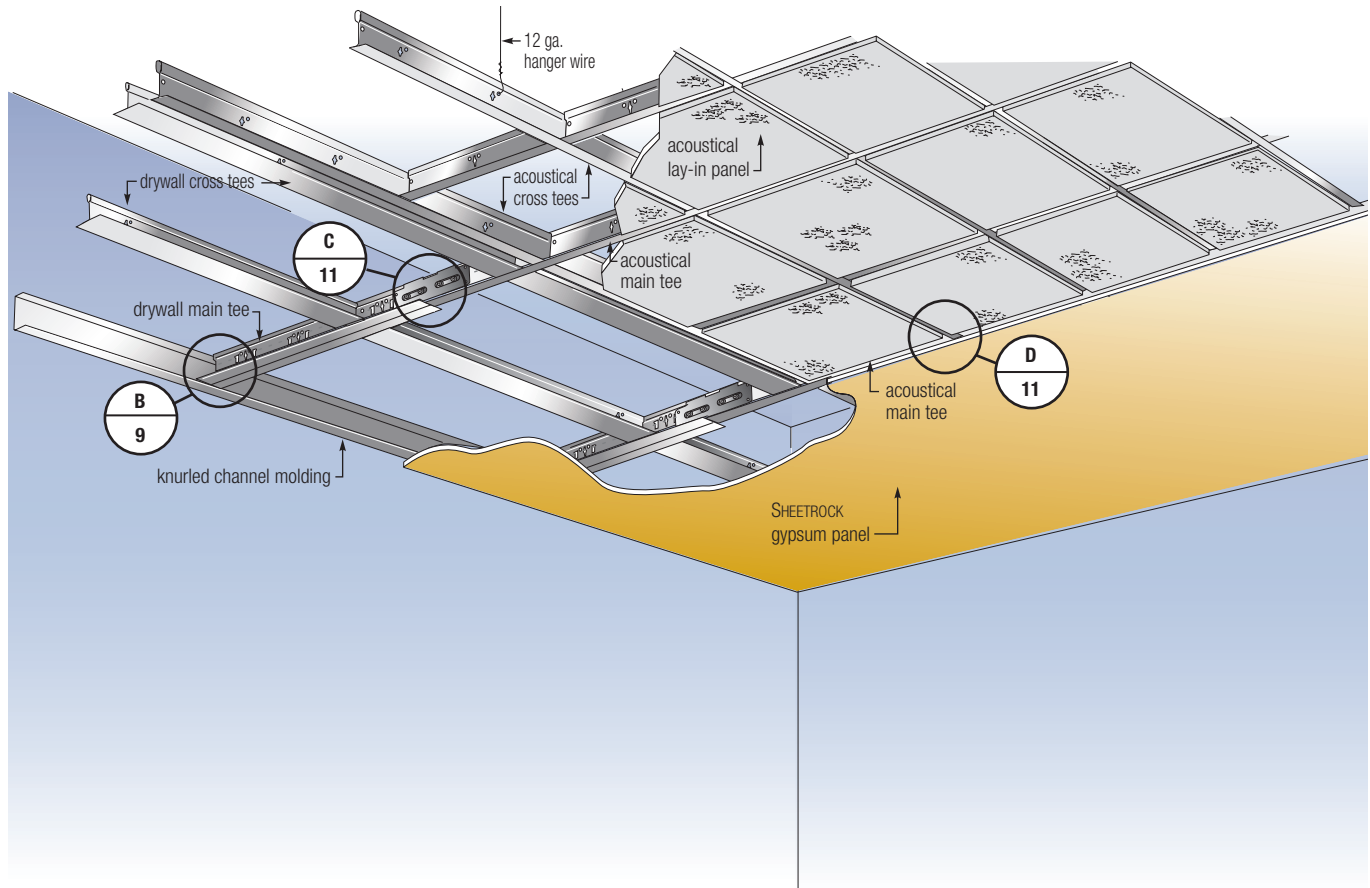

The new USG Drywall Suspension System is fully compatible with our USG Donn® Brand DX®/DXL™, DXSS, DXW and Centricitee™ acoustical suspension systems, making it easy to transition between flat drywall and acoustical ceilings. Flush or offset transitions are possible. Additional cross tees are necessary at drywall edge to provide adequate support (as shown on next page).

Note: These renderings and details are provided for illustrative purposes only and are not a substitute for certified architectural and engineering drawings, nor do they necessarily reflect national and local building code requirements. For additional information, see specifications on page 47 or call Technical Service at 800.USG.4YOU.

TRANSITIONS

Drywall to Acoustical Ceilings

Plan view

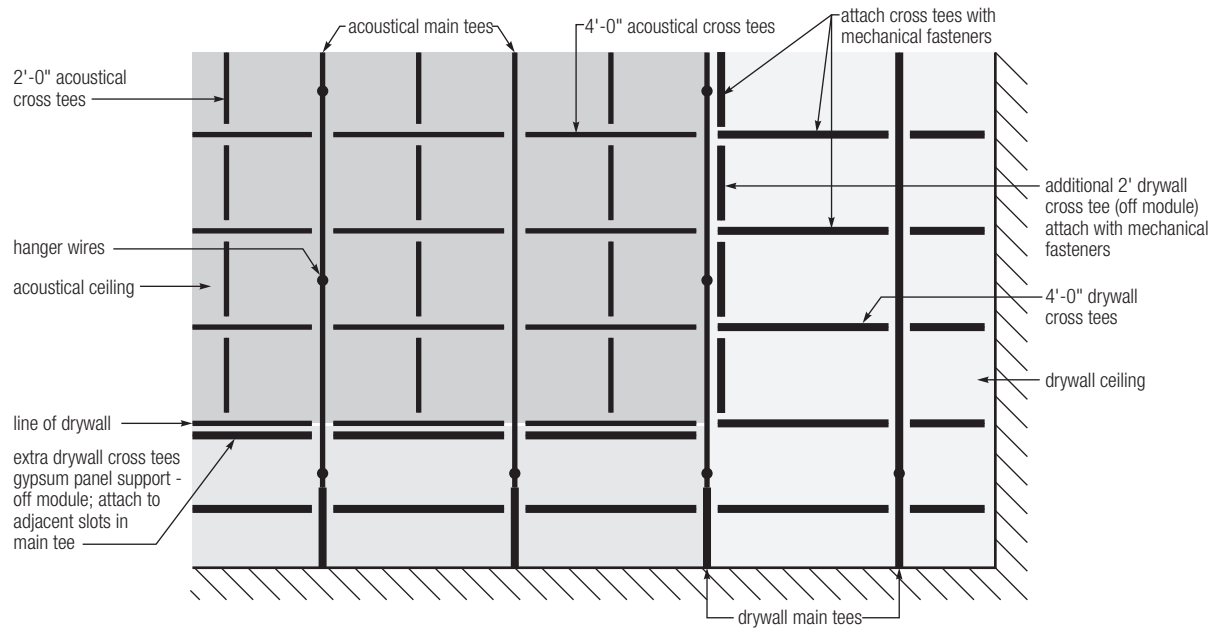

Drywall-to-acoustical transition—field-cut connection

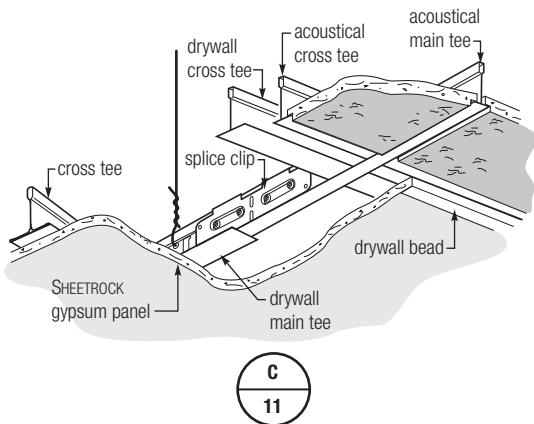

Drywall-to-acoustical transition

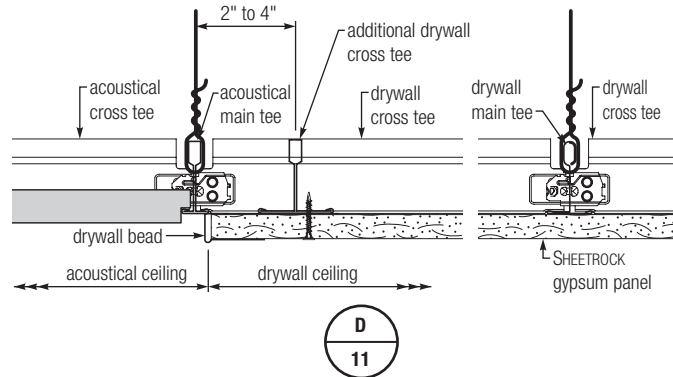

Drywall-to-acoustical transition—factory-end connection

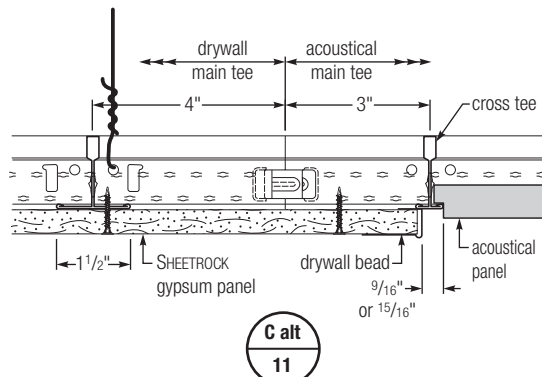

Flush transition

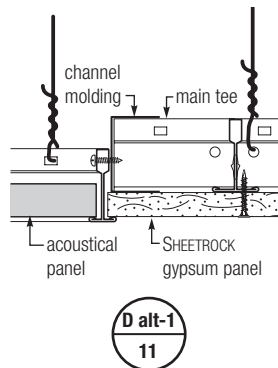

Standard offset

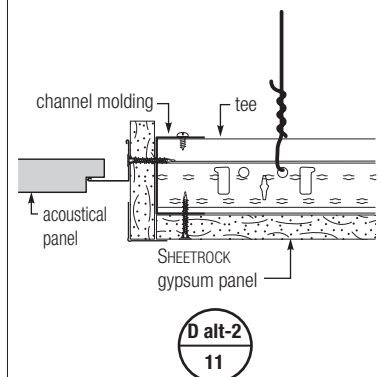

BOXED SOFFITS Flat Drywall Ceilings

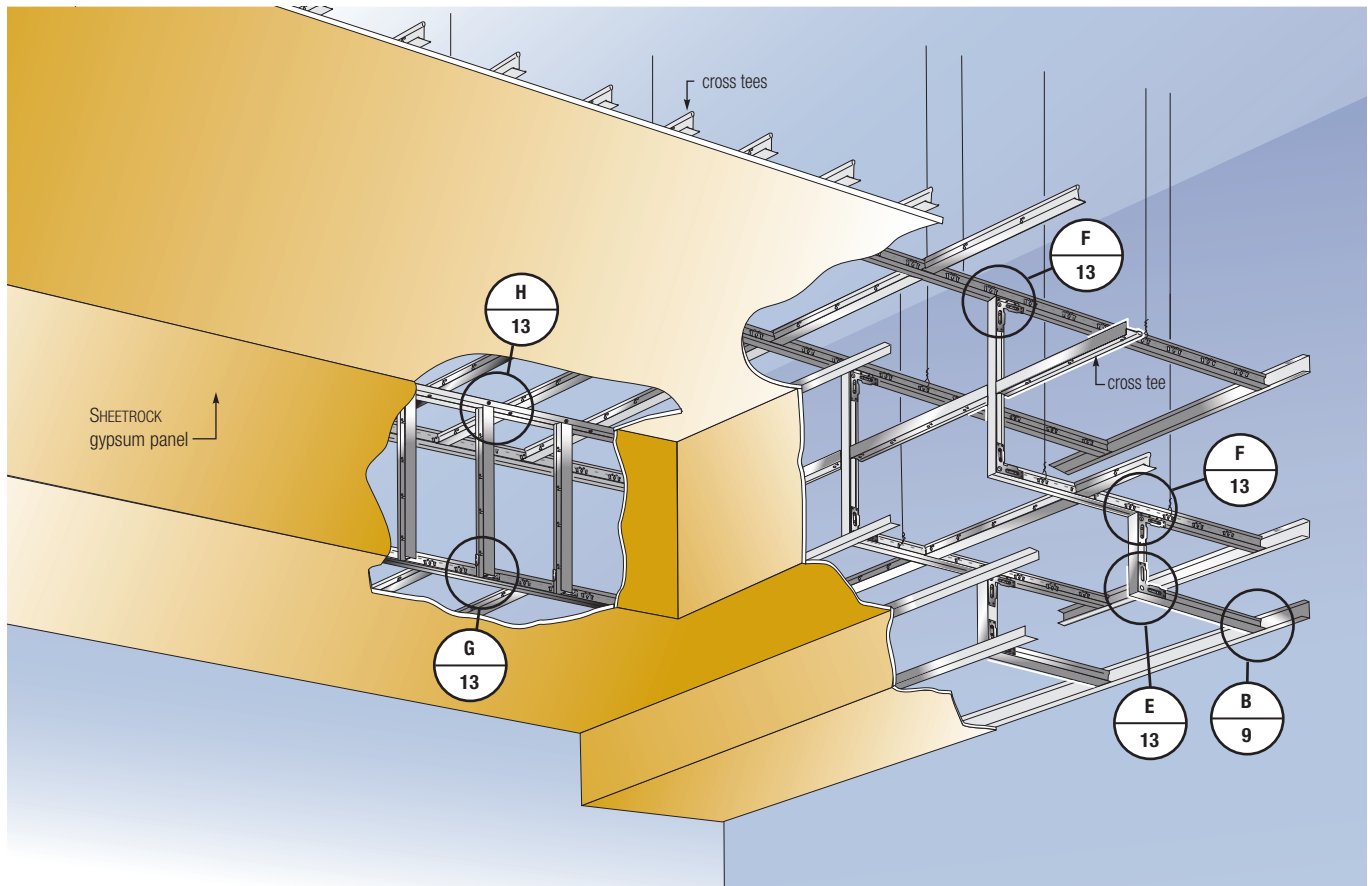

Soffit suspension system components are identical to the components used in flat surface areas.

- When constructing soffits, bracing of the drywall suspension and/or additional hanger wires may be necessary to ensure stability and structural performance during and after drywall attachment.
- The maximum vertical soffit height is 48" with cross tees spaced 24" on center. (Maximum unsupported drywall area is 48" x 24".) Intermediate cross tees are not necessary when soffit dimensions do not exceed 24".
- When used in soffit construction, all transition clips are to have a minimum of 4 screws for attachment.

Note: In the image above, some hanger wires, bracing, and grid components have been omitted for clarity. These renderings and details are provided for illustrative purposes only and are not a substitute for certified architectural and engineering drawings, nor do they necessarily reflect national and local building code requirements. For additional information, see specifications on page 47 or call Technical Service at 800 USG.4YOU.

BOXED SOFFITS

Flat Drywall Ceilings

90° outside corner using transition clip

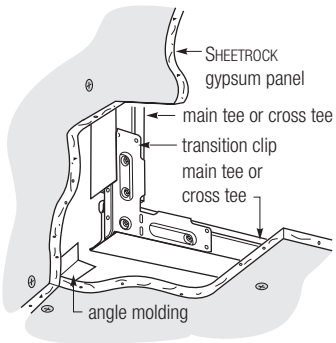

E
13

90° outside corner with field-cut tee

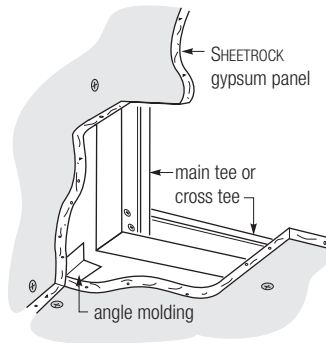

E alt
13

90° inside corner

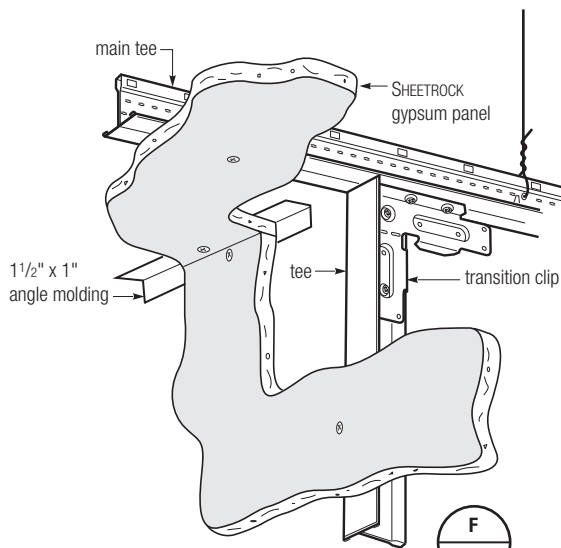

F
13

90° outside corner with main tee at bottom edge

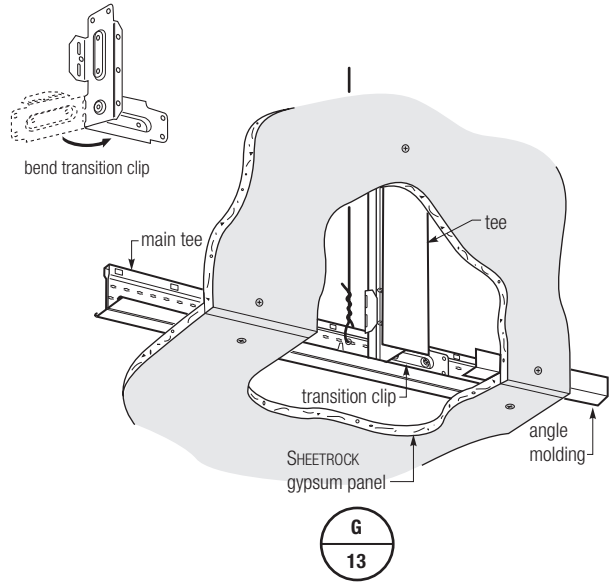

G
13

90° inside corner with channel molding at top edge

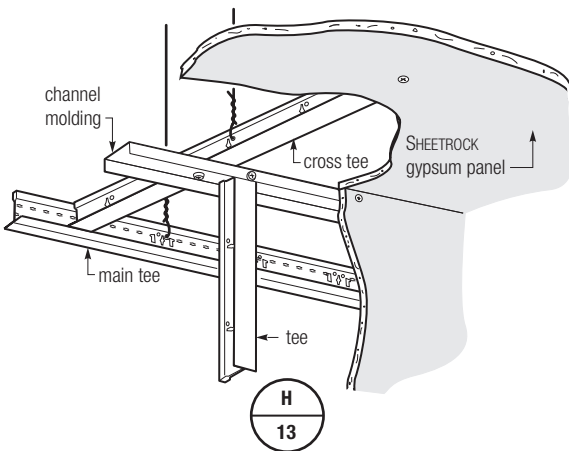

H
13

CURVED SOFFITS

Curved Drywall Ceilings

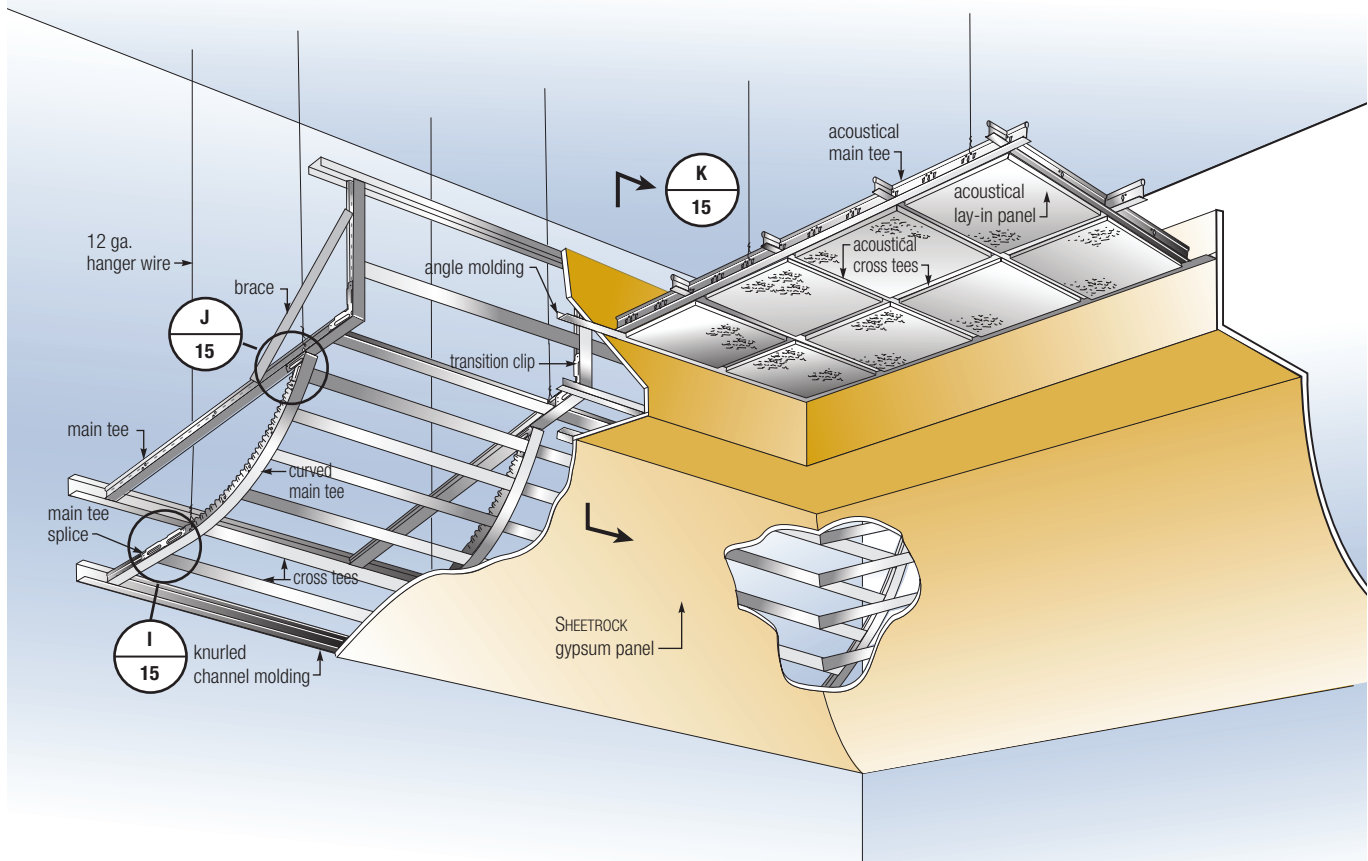

Radiused soffits can be constructed using curved drywall suspension main tees. Factory-radiused main tees eliminate field bending and can reduce installation time.

- When constructing curved soffits, bracing of the drywall suspension and/or additional hanger wires may be necessary to ensure stability and structural performance during and after drywall attachment. See page 12 for hanger-wire spacing requirements.
- The maximum vertical soffit is 48" with cross tees spaced 24" on center. (Maximum unsupported drywall is 48" x 24".) Intermediate cross tees are not necessary when soffit dimensions do not exceed 24".
- All transition and splice clips are to have a minimum of 4 screws for attachment.

Note: In the image above, some hanger wires, bracing, and grid components have been omitted for clarity. These renderings and details are provided for illustrative purposes only and are not a substitute for certified architectural and engineering drawings, nor do they necessarily reflect national and local building code requirements. For additional information, see specifications on page 47 or call Technical Service at 800 USG.4YOU.

CURVED SOFFITS

Curved Drywall Ceilings

Curved soffit to boxed soffit—valley to flat

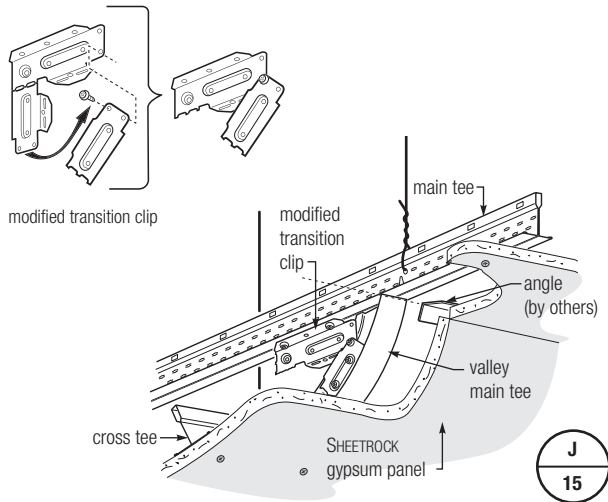

Section through soffit and acoustical transition

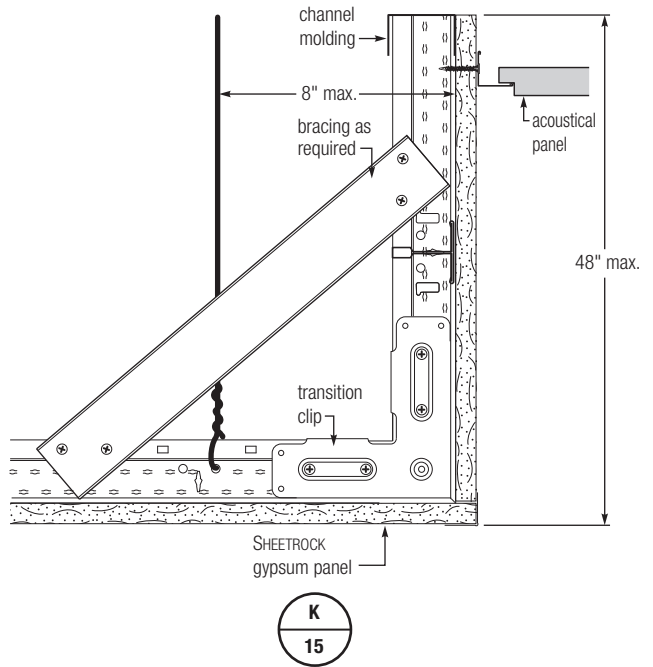

Curved soffit—flat to valley

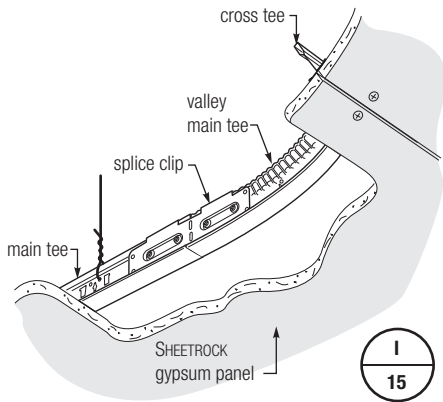

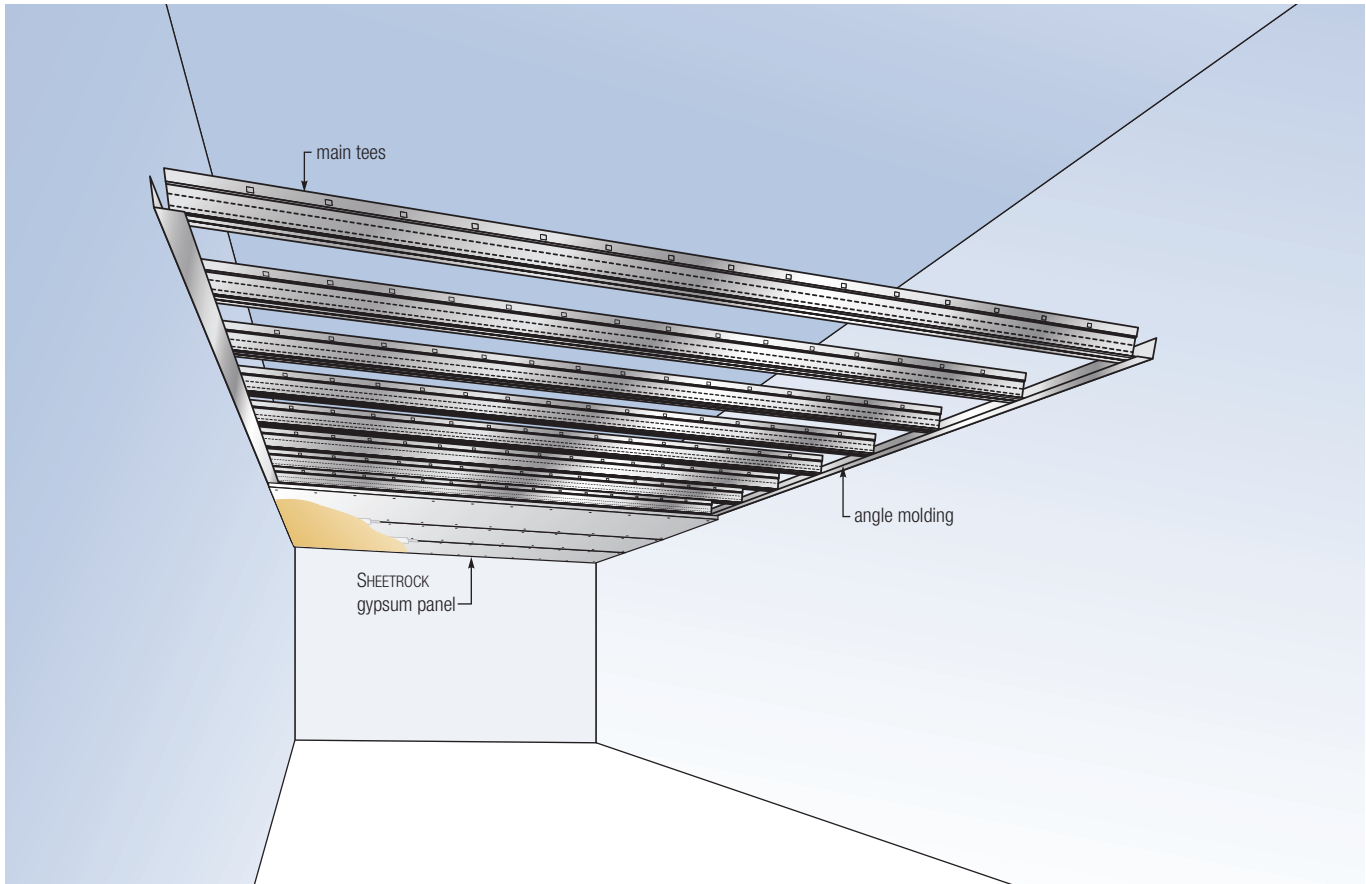

The USG Wall-to-Wall Drywall Suspension System is designed for use in corridors and smaller rooms as an alternative to conventional framing methods. The system is ideal for areas with tight deck clearance, or with crowded plenum space because of mechanical, electrical and HVAC systems. The Wall-to-Wall system can span up to 8' with no hangers and up to 22'-6" with intermediate supports.

The system assembles quickly and easily, framing narrower spaces efficiently and with a minimum of components. System accessories and integrated straight components offer easy transitions to vertical, horizontal or curved surfaces.

The Wall-to-Wall Drywall Suspension System includes 6', 8', 10', 12' and 14' double-web; rotary stitched knurled tees; and 12" knurled wall molding. Tees are tested in accordance with the uniform load test procedures outlined in ASTM Standard C635. Loads are limited to L/240 of each span, per ASTM C645.

Framing Requirements

Gypsum Framing Requirements

Panel Type	Main-Tee Spacing	Support Requirement	Max Span
1/2" USG Sheetrock® Brand Panels 5/8" USG Sheetrock® Brand Panels Firecode 30	16" OC	none	8'
		one, mid-span	16'
		two, 1/3 points	24'
5/8" USG Sheetrock® Brand Panels	16" OC	none	7'-6"
		one, mid-span	15'
		two, 1/3 points	22'-6"
5/8" USG Sheetrock® Brand Panels	24" OC	none	6'-6"
		one, mid-span	13'
		two, 1/3 points	19'-6"

Membrane Loads

Main Tee Span	Spacing, OC	Intermediate Supports	Maximum Loads (lbs-sf)
5'	16"	none	11.5
	24"	none	7.7
6'	16"	none	6.6
	24"	none	4.4
7'	16"	none	4.2
	24"	none	2.8
7'-6"	16"	none	3.4
	24"	none	2.3
8'	16"	none	2.8
	24"	none	1.7
	24"	one, midspan	15
10'	16"	one, midspan	11.5
	24"	one, midspan	7.6
12'	16"	one, midspan	6.6
	24"	one, midspan	4.4
14'	16"	one, midspan	4.2
	24"	one, midspan	2.8

Note: Maximum main-tee length is 14'. Spans longer than 14' require main tees to be spliced together. See splice options on the following page.

Wall-to-Wall System

Support Requirements

Spans exceeding 7'-6" for 5/8" and 8'-0" for 1/2" gypsum panels can be supported with the Indexed Support Bar ISB112. Vertical supports at 4' OC are attached to the ISB112. For more detailed information regarding installing the ISB112, refer to product data sheet SC2629.

Main-Tee Splice Options

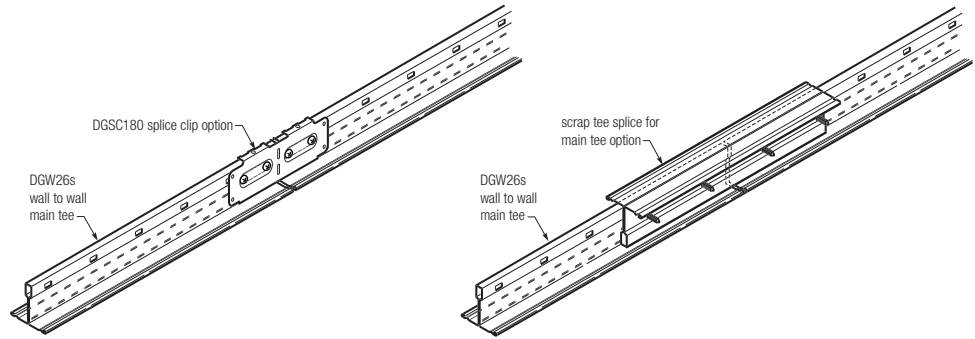

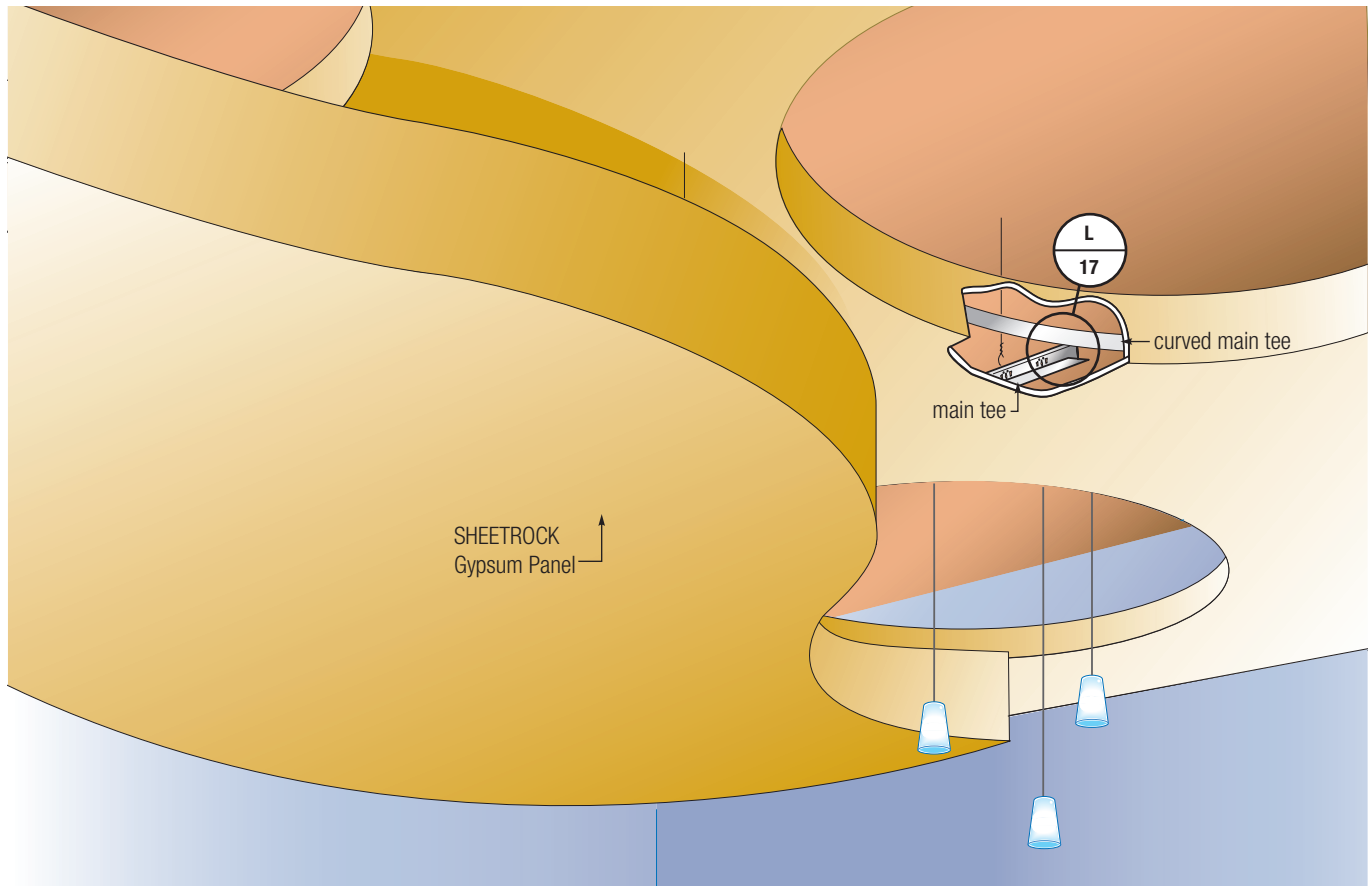

Curved drywall fascias can be engineered and built with the USG Drywall Suspension System. The framing for the fascia is constructed from curved main tees installed horizontally.

- Main-tee and cross-tee spacing is provided in the table on page 31.
- Hanger wires must be placed within 12" of the fascia where main tees and cross tees intersect the fascia.
- Extra hanger wires may be required at the perimeter of fascia applications to ensure adequate support and stability, such as cross tees less than 12" in length.

Note: These renderings and details are provided for illustrative purposes only and are not a substitute for certified architectural and engineering drawings, nor do they necessarily reflect national and local building code requirements. For additional information, see specifications on page 47 or call Technical Service at 800 USG.4YOU.

Flat Drywall Ceilings

Curved drywall fascia (up to 8" max.) for flat ceilings

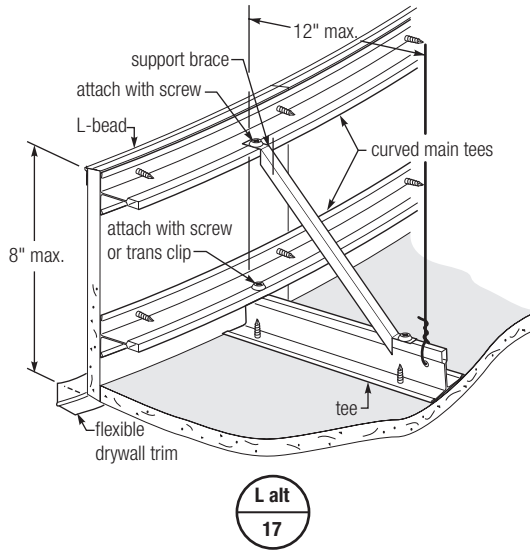
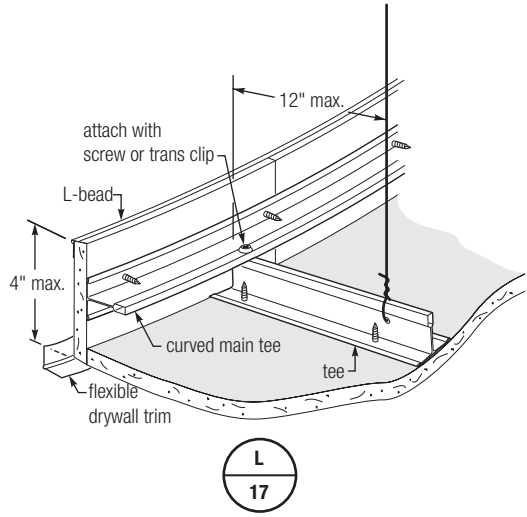

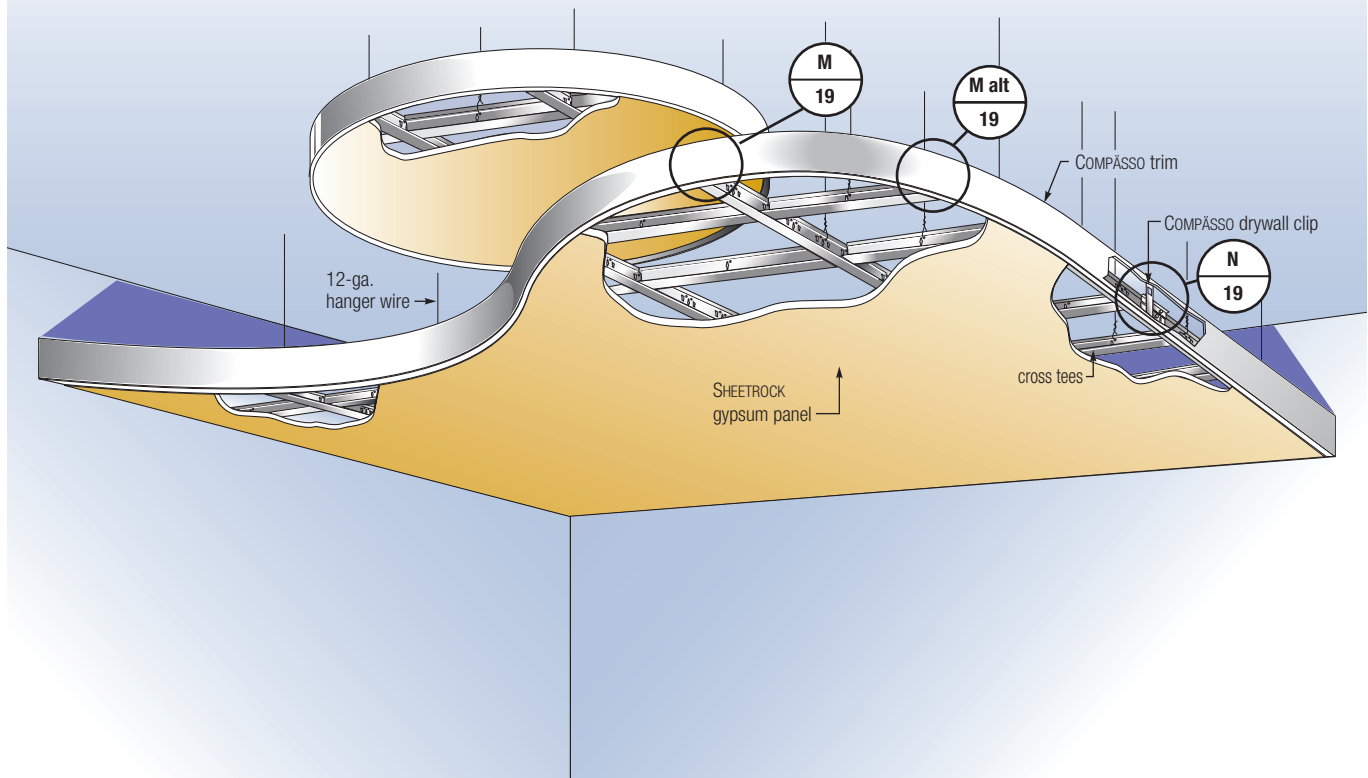

USG Compässö suspension trim is designed to be installed on the Drywall Suspension System using Compässö drywall clips. This is an effective alternative to gypsum board fascias for accent ceilings.

- Main-tee and cross-tee spacing is provided in the table on page 31.
- Hanger wires must be placed within 12" of the fascia where main tees and cross tees intersect the fascia.
- Extra hanger wires may be required at the perimeter to ensure adequate support for cross tees less than 12" in length.

Note: These renderings and details are provided for illustrative purposes only and are not a substitute for certified architectural and engineering drawings, nor do they necessarily reflect national and local building code requirements. For additional information, see specifications on page 47 or call Technical Service at 800 USG.4YOU.

Flat Drywall Ceilings

Compasso Trim perpendicular to main tee or cross tee

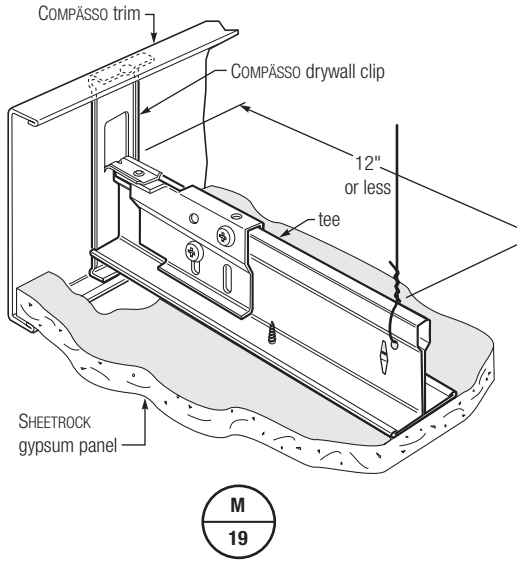

Compasso Trim parallel to main tee or cross tee

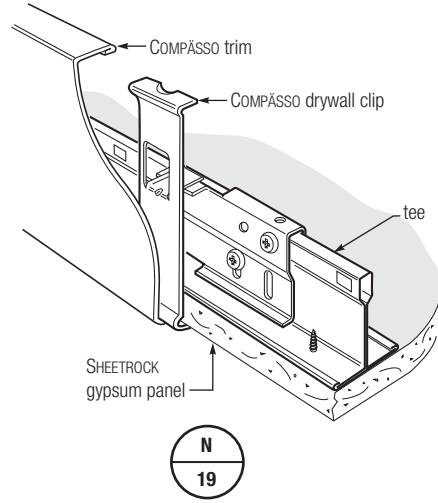

View from above

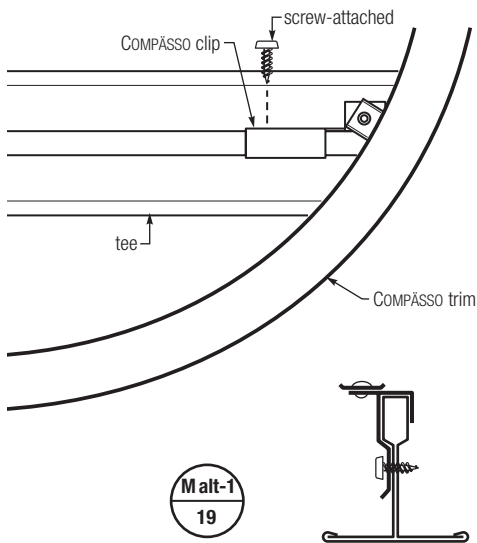

View from above

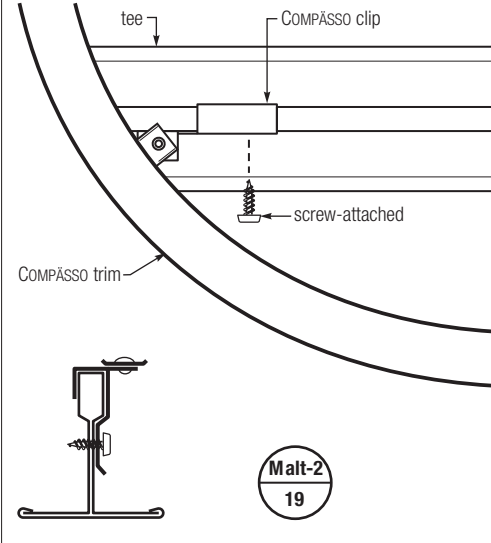

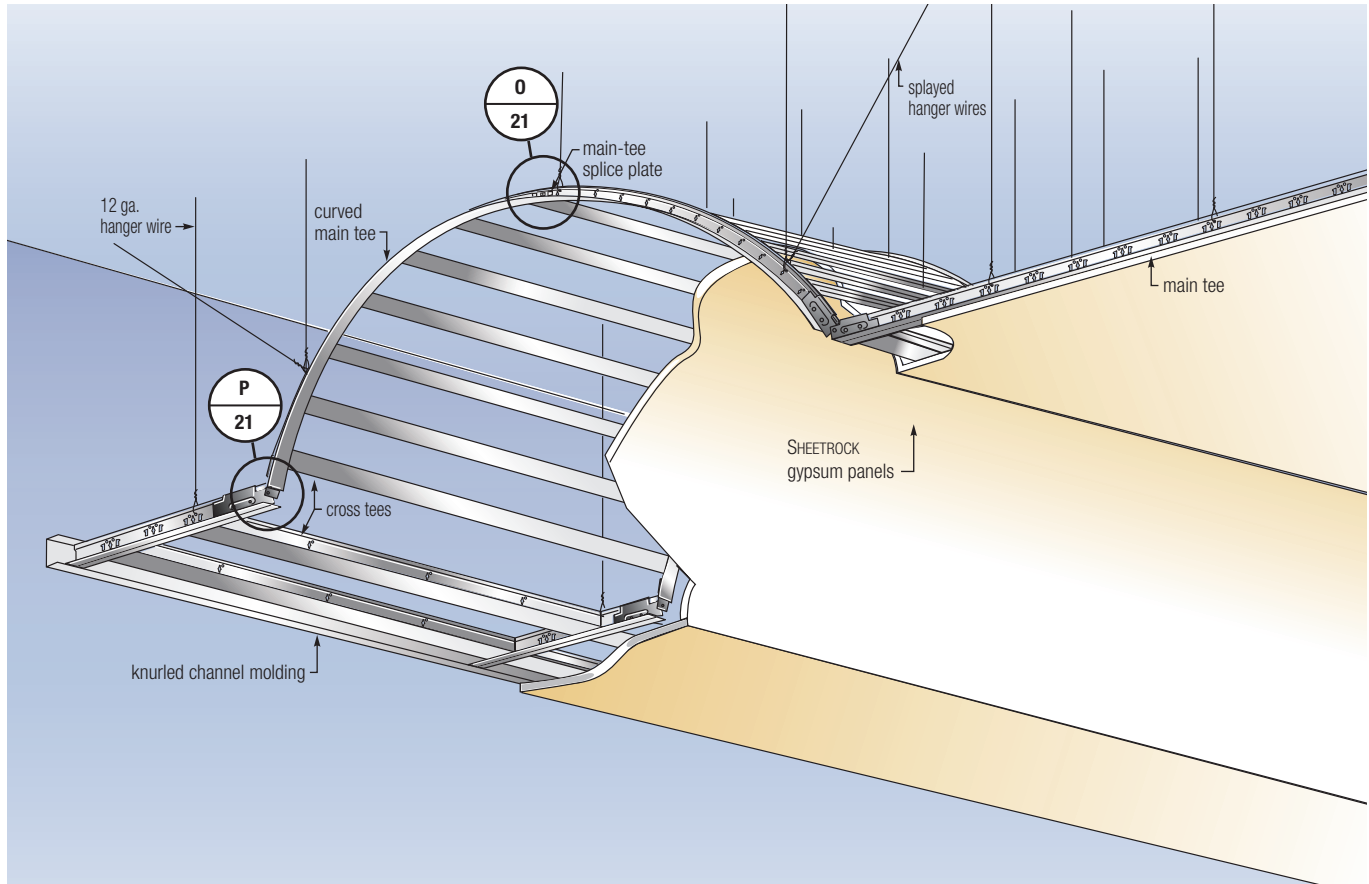

Curved main tees are factory bent and used to construct barrel vaults, archways, valleys, and waves with the USG Drywall Suspension System. DGSC-180 splice clips are used for attaching the curved main tees to flat ceilings, soffits or acoustical suspension systems.

- Hanger wires shall be spaced a maximum of 48" along the arc of main tee vaults.
- Additional hanger wires or bracing may be necessary to stabilize curved ceilings during and after drywall attachment.
- At least 1 hanger wire is required within 8" of a curved main-tee splice.
- Hanger wires are required within 8" on both sides of a modified splice clip attached to the nearest hanger holes.
- At least 1 hanger wire is required within 8" of a transition clip.
- All drywall joints must be a minimum of 12" from all main-tee splices.

Note: In the image above, some hanger wires, bracing, and grid components have been omitted for clarity. These renderings and details are provided for illustrative purposes only and are not a substitute for certified architectural and engineering drawings, nor do they necessarily reflect national and local building code requirements. For additional information, see specifications on page 47 or call Technical Service at 800.USG.4YOU.

Curved Drywall Ceilings

Vault to vault—factory-end connection

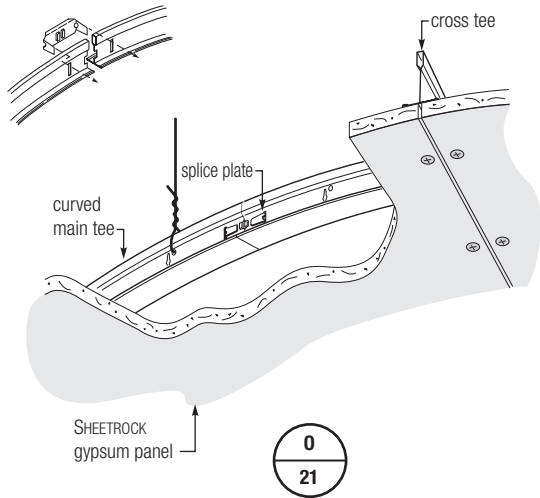

Vault to vault—field-cut

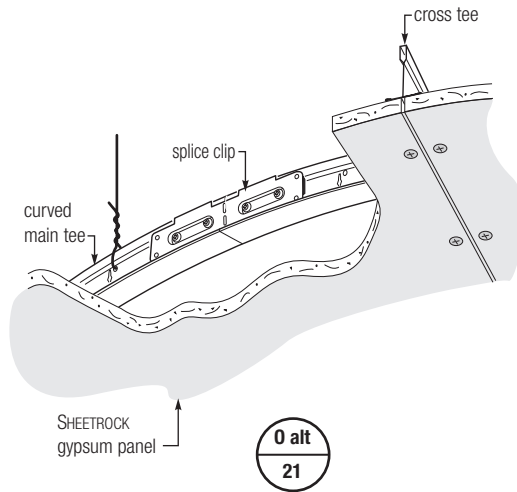

Flat to vault with angle greater than 90°

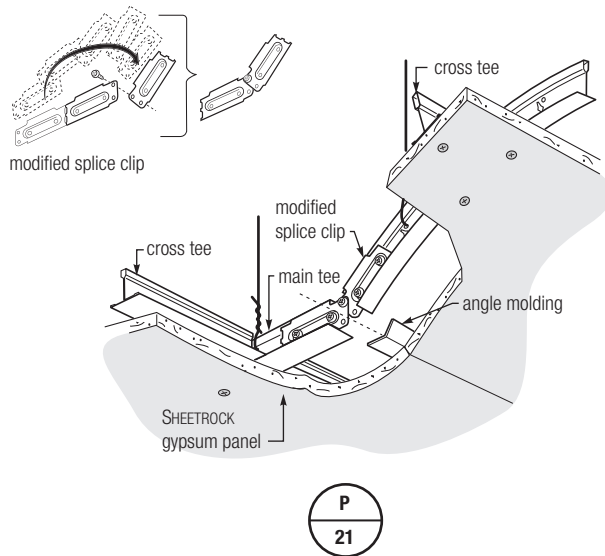

Flat to vault with 90° angle (not shown in preceding perspective)

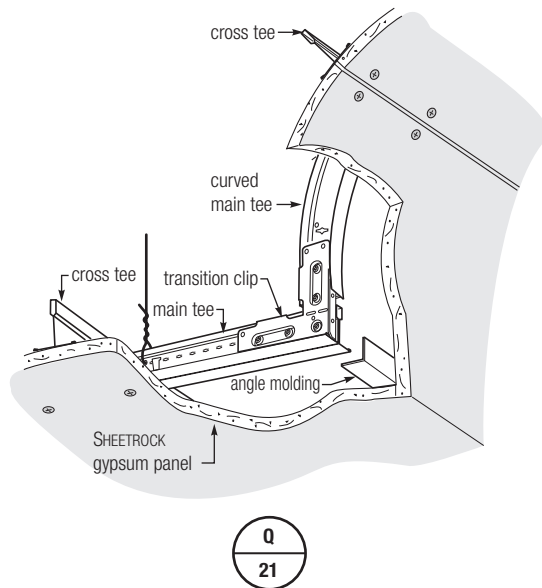

VAULTS AND VALLEYS

Curved Drywall Ceilings

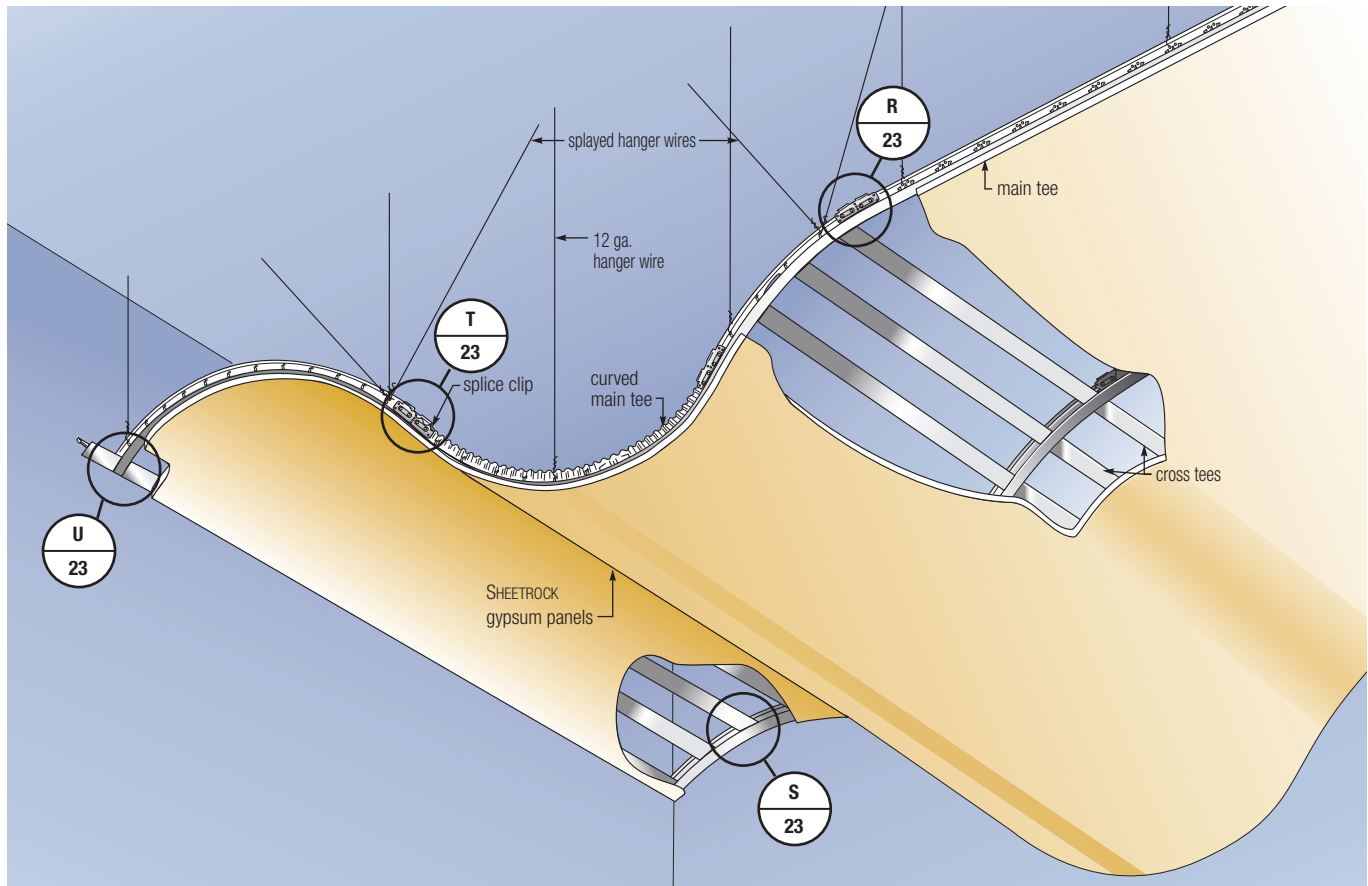

The USG Drywall Suspension System simplifies constructing serpentine ceilings. Factory-formed curved vault and valley main tees are spliced together using the DGSP-180 splice plate.

- Hanger wires shall be spaced a maximum of 48" along the arc vaults main tees.
- Hanger wires shall be spaced a maximum of 24" along the arc of valley main tees.
- Additional hanger wires or bracing may be necessary to stabilize curved ceilings during and after drywall attachment.
- At least 1 hanger wire is required within 8" of a standard curved main-tee splice.
- Hanger wires are required within 8" on both sides of a modified splice clip attached to the nearest hanger holes.
- At least 1 hanger wire is required within 8" of a transition clip.
- All drywall joints must be a minimum of 12" from all main-tee splices.

Note: In the image above, some hanger wires, bracing, and grid components have been omitted for clarity. These renderings and details are provided for illustrative purposes only and are not a substitute for certified architectural and engineering drawings, nor do they necessarily reflect national and local building code requirements. For additional information, see specifications on page 47 or call Technical Service at 800.USG.4YOU.

Curved Drywall Ceilings

Vault to flat—field-cut connection

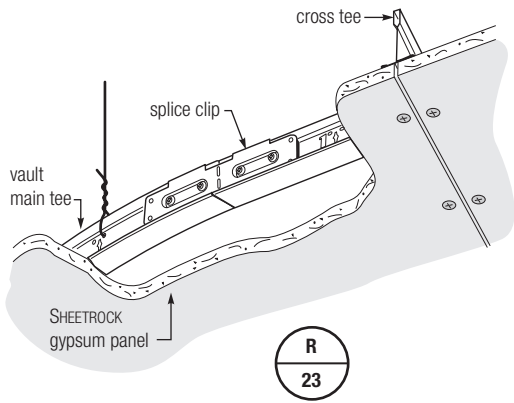

R
23

Curved main tee to parallel wall connection

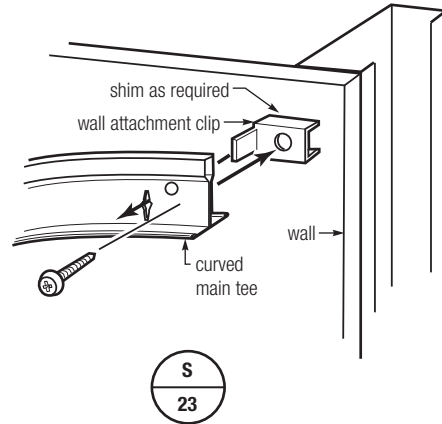

S
23

Vault to valley—field-cut connection

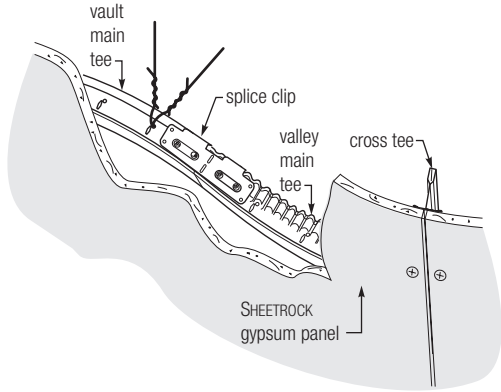

T
23

Vault to valley—factory-end connection

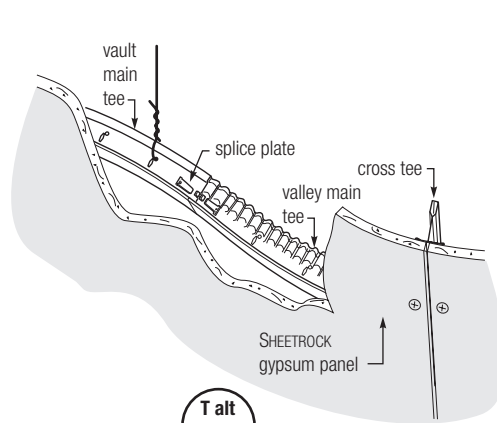

T alt
23

Curved main tee perpendicular to wall connection (section and isometric view)

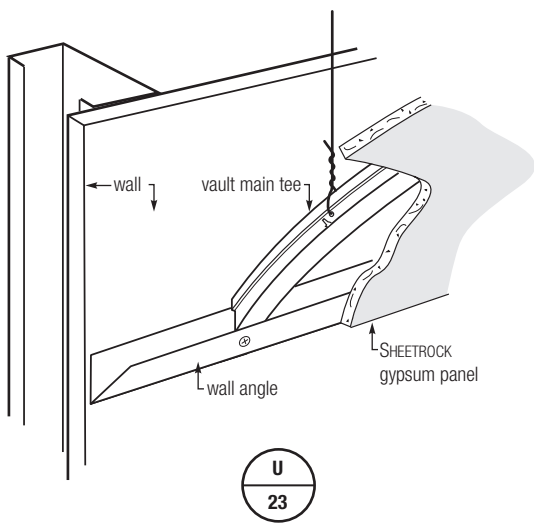

U
23

Acute intersection vault tee

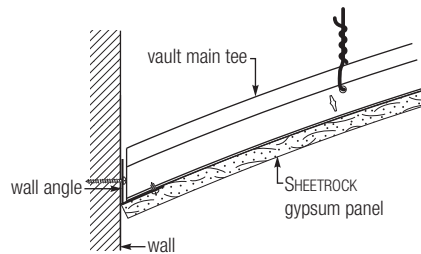

VAULTS AND VALLEYS

Curved Drywall Ceilings

Panel Selector for Curved Ceilings

	Curved Main Tees ⁵					Gypsum Board Thickness Options ⁶	
	Radius	Arc Length	Cross-Tee Spacing	Item No.	Hanger-Wire Spacing	Parallel ⁷	Perpendicular ⁷
Vault	31"-44"	68	8" OC	DGW6VTxxx	48"	—	1/4" flex double layer ⁸
	45"-60"	88	8" OC	DGW8VTxxx	48"	—	1/4" double layer
	61"-91"	108	8" OC	DGW10VTxx	48"	1/4" double layer ⁸	1/4" double layer
	92"-239"	108	16" OC	DGW10VTxxx	48"	1/4" double layer or 3/8"	1/4" double layer or 3/8"
	240"+	128	16" OC	DGW12VTxxx	48"	1/4" double layer or 1/2"	1/4" double layer or 1/2"
Valley	31"-44"	68	8" OC	DGW6VYxxx	24"	—	1/4" flex double layer
	45"-60"	88	8" OC	DGW8VYxxx	24"	—	1/4" double layer
	61"-91"	108	8" OC	DGW10VYxxx	24"	1/4" double layer	1/4" double layer
	92"-239"	108	16" OC	DGW10VYxxx	24"	1/4" double layer or 3/8"	1/4" double layer or 3/8"

⁵ All curved main tees are to be spaced 48" OC.

⁶ In a multiple-radius curved ceiling, select panel thickness based on the smallest radius in the design.

⁷ See drawings below.

⁸ 1/4" gypsum panels must be applied in a double layer for durability and finishing.

Parallel Application of Drywall

"Parallel" refers to the long wrapped edges of the gypsum panel applied **parallel** to the curved main tees.

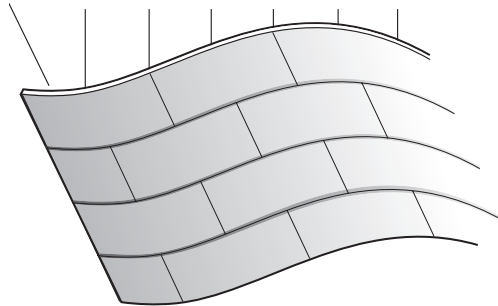

Perpendicular Application of Drywall

"Perpendicular" refers to the long wrapped edges of the gypsum panels applied **perpendicular** to the curved main tees.

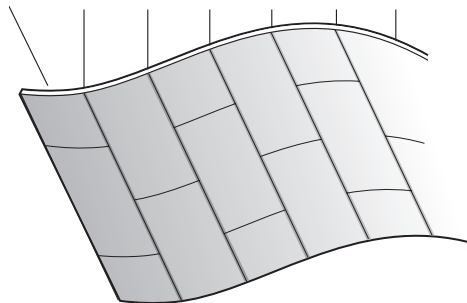

Curved Drywall Ceilings

Bending Radius for Gypsum Panels

Minimum Bending Radii of Dry Gypsum Board¹

Board Thickness		Board Applied with Long Dimension Perpendicular to Framing		Board Applied with Long Dimension Parallel to Framing	
in.	mm.	ft.	m	ft.	m
1/4	6.4	3	0.9	5	1.8
3/8	9.5	6	1.8	9	2.7
1/2	12.7	12	3.7	—	—
5/8	15.9	18	5.5	—	—

¹Comparable information is available for USG Fiberock® Brand Panels. See the most current literature of USG Fiberock® Brand Panels for data.

Minimum Radii of USG Sheetrock® Brand 1/4" Flexible Gypsum Panels

Application	Condition	Lengthwise Bend Radii		Max. Stud Spacing		Widthwise Bend Radii		Max. Stud Spacing	
		in.	mm	in.	mm	in.	mm	in.	mm
Inside (concave)	Dry*	32	813	9	229	45	1143	9	229
Outside (convex)	Dry*	34	864	9	229	20	508	6	152

*At 75° F/50% relative humidity.

Minimum Bending Radii of Wetted Gypsum Board¹

Board Panel Thickness	Radius	Inside Length of Arc ²	Outside Length of Arc ²	No. of Studs on Arc Including at Tangents ³	Approx. Stud Spacing c. to c. ⁴	Max. Stud Spacing c. to c. ⁴	Oz. of Water Required per One-Side-oz ⁵
1/4"	2'0"	3.14'	44.0"	9	5.50"	6"	30
1/4"	2'6"	3.93'	53.4"	10	5.93"	6"	30
3/8"	3'0"	4.71'	62.8"	9	7.85"	8"	35
3/8"	3'6"	5.50'	72.2"	11	7.22"	8"	35
1/2"	4'0"	6.28'	81.6"	8	11.70"	12"	45
1/2"	4'6"	7.07'	91.1"	9	11.40"	12"	45

¹For gypsum board applied horizontally to framing members.

²Arc length = $\frac{3.14R}{90}$ (for a 90° arc).

³No. studs = outside arc length/maximum spacing + 1 (rounded up to next whole number).

⁴Stud spacing = outside arc length/no. of studs - 1 (measured along outside of runner).

⁵Wet only the side of board that will be in tension, water required per board side is based on 4'x8' sheet

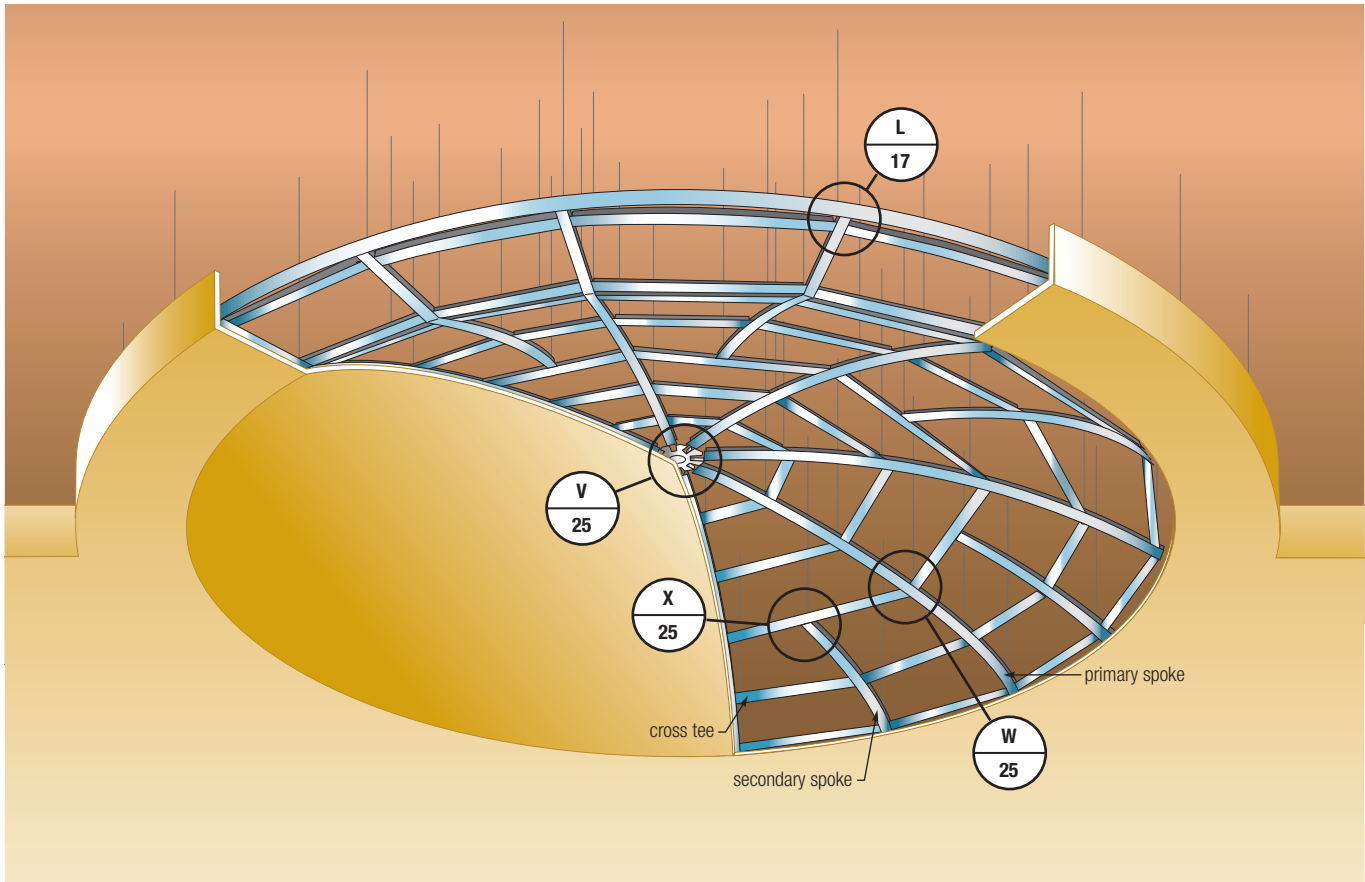

USG offers pre-engineered solutions for framing domed ceilings. Curved main tees are factory-bent to form spokes and cross tees for the dome frame system. This eliminates jobsite bending required with conventional framing methods. Domes can then be finished using either gypsum board or lath and plaster.

- Hanger wires shall be spaced a maximum of 32" along each spoke.
- Additional secondary spokes are required when spacing between primary spokes exceeds 48".
- Hanger wires are required at both ends of all secondary spokes.
- Cross tees are required 16" OC maximum.

Curved Drywall Ceilings

Hub and primary spokes

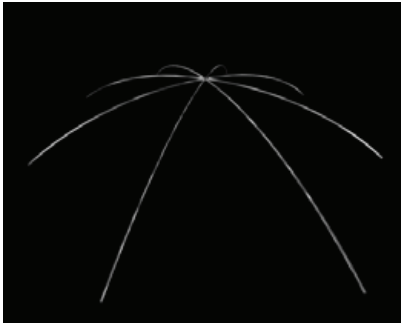

First header and secondary spokes

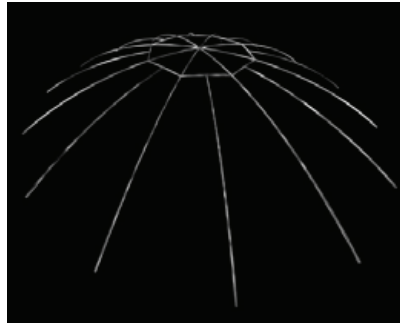

Second header and secondary spokes

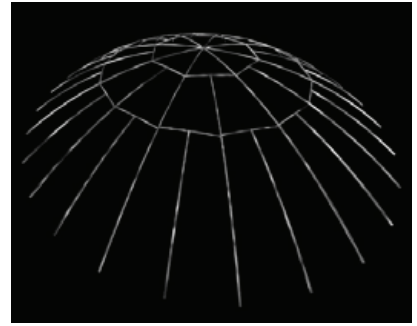

Cross tees

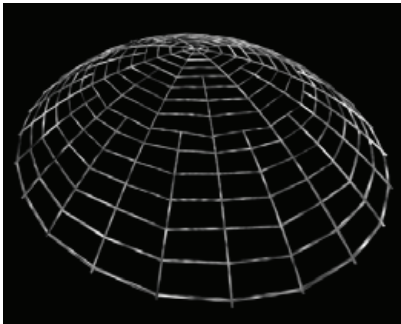

Lath and plaster finish

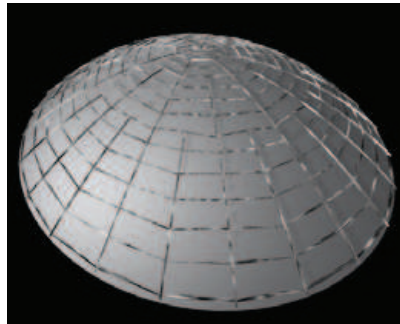

Detail 1: Top-connector spoke hub

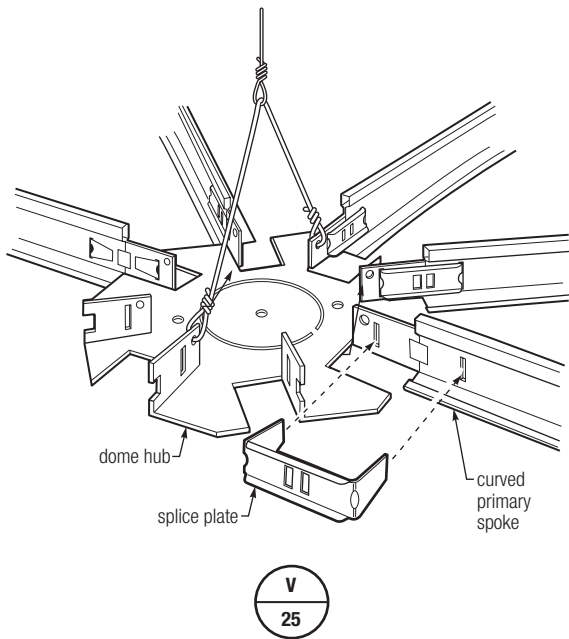

Detail 2: Header-to-spoke connection

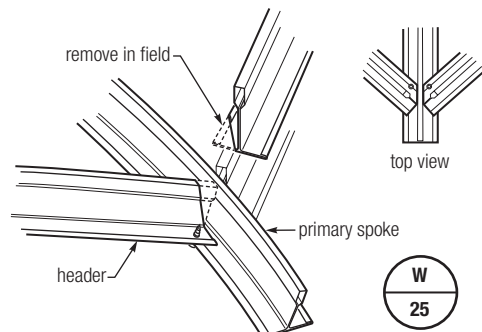

Detail 3: Secondary spoke connection

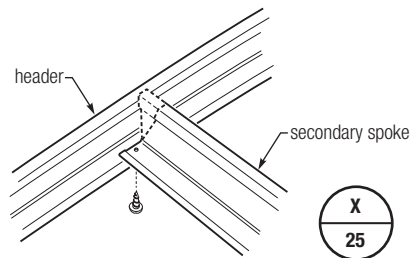

UTILITY INTERFACES

Flat Drywall Ceilings

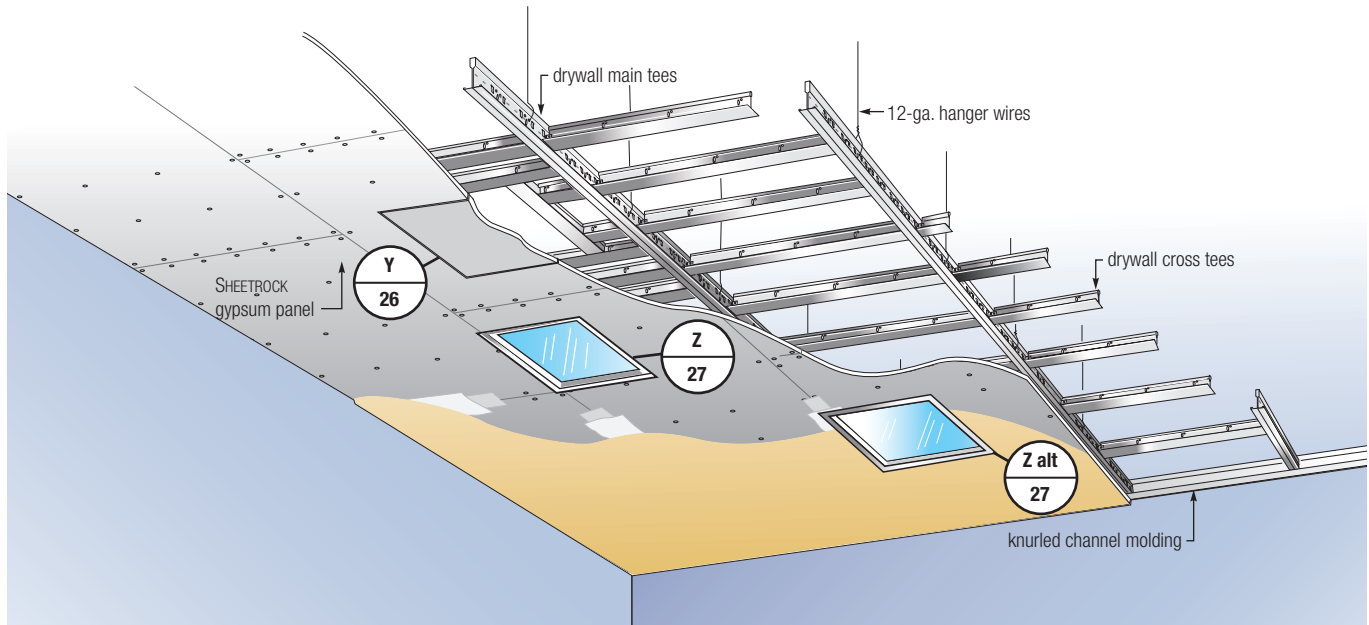

The USG Drywall Suspension System easily accommodates conventional light fixtures, access doors or HVAC ceiling diffusers.

Note: These renderings and details are provided for illustrative purposes only and are not a substitute for certified architectural and engineering drawings, nor do they necessarily reflect national and local building code requirements. For additional information, see specifications on page 47 or call Technical Service at 800 USG.4YOU.

Access door

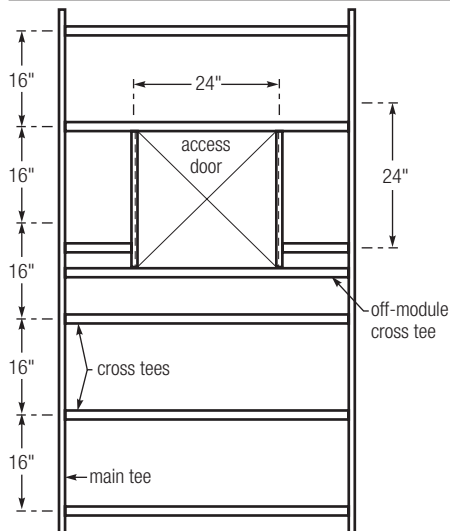

Access door

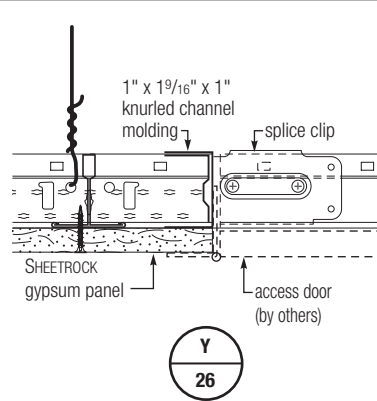

Flat Drywall Ceilings

Type G light fixture

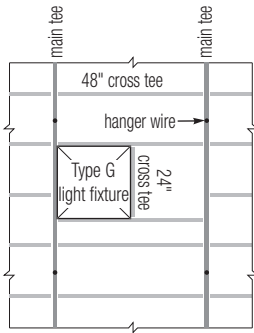

A Type G fixture, commonly used in suspended acoustical suspension ceilings, requires 15/16"-face main or cross tees to be located on either 24" or 48" centers. Drywall is cut even with the grid flanges and trimmed with J- or L-bead. The fixture is passed through the opening and lowered to rest on the grid flanges.

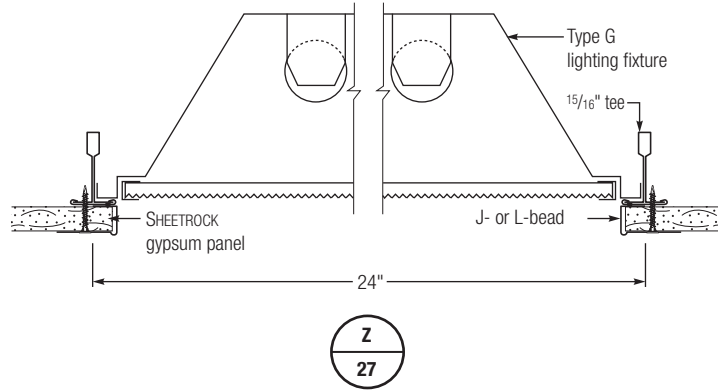

Type F light fixture

A Type F light fixture has lower flanges that cap the cut edges of the drywall. This fixture typically requires a full 24" or 48" opening, and many systems require grid members to be installed "off-module" to accommodate the light. All USG Drywall Suspension System main tees are factory-punched with a three-slot cross tee hole pattern every 8" so that Type F light fixtures can be positioned in a variety of locations within a grid opening without field-modifying support tees. Type F light fixtures are raised into the opening until the flanges contact the ceiling. Securing devices on the fixture are adjusted to suspend the fixture from the grid and pull it tight to the ceiling surface.

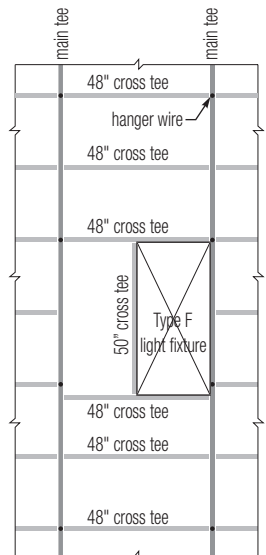
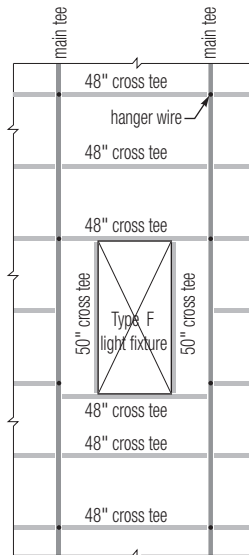
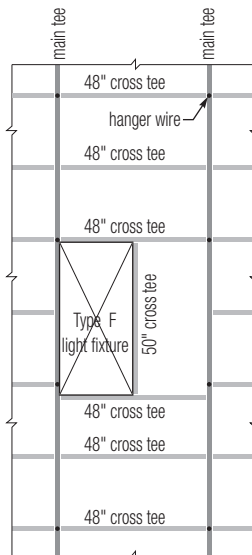
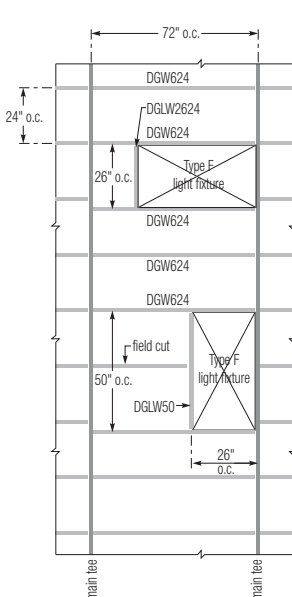
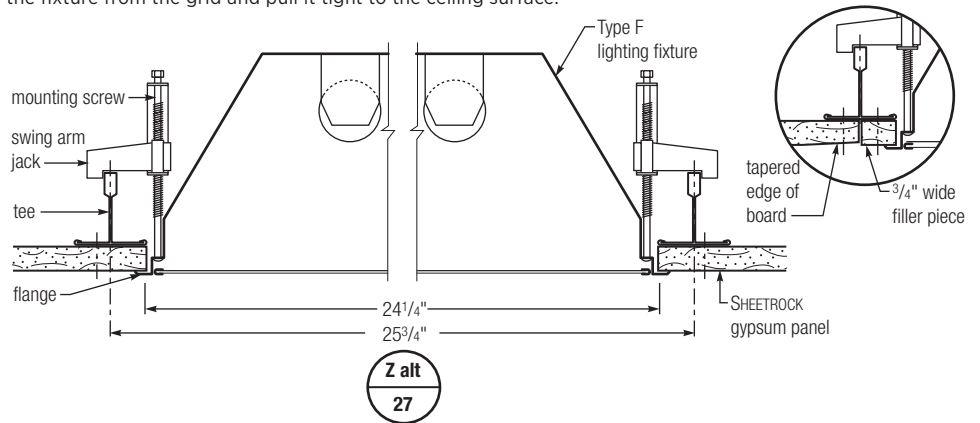

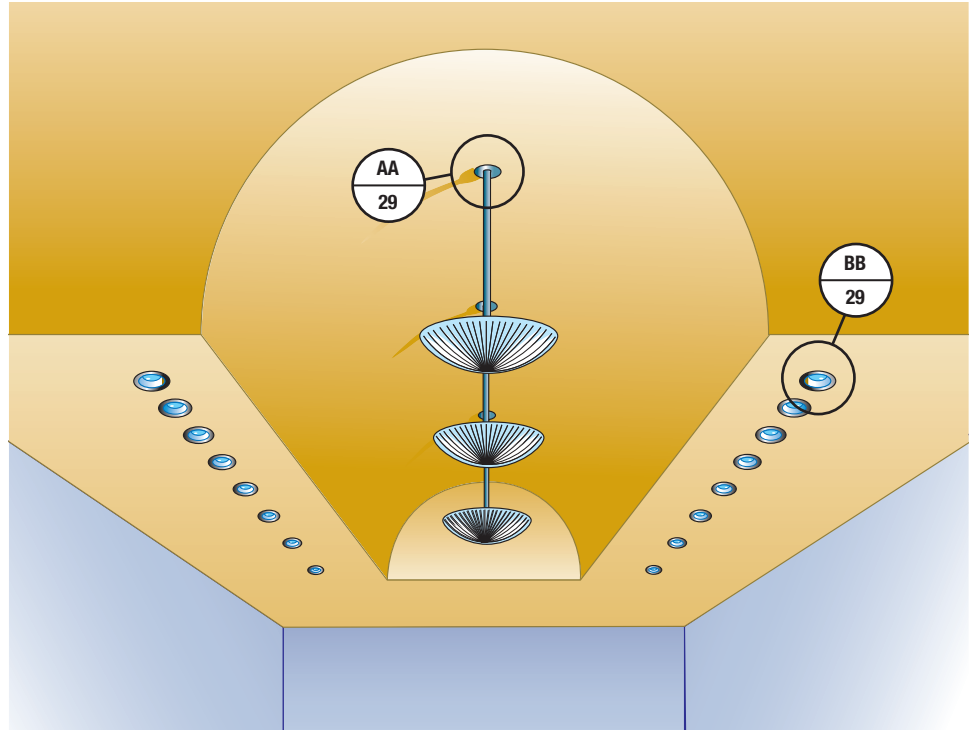

Curved drywall ceilings create exciting lighting design opportunities. The interface of light fixtures with curved ceiling surfaces requires careful design consideration. Stem- and cable-style indirect and direct light choices are possible solutions. Recessed flat sections can be built into curved sections to accommodate light fixtures. Sconces are also very effective with a vaulted ceiling.

Note: These renderings and details are provided for illustrative purposes only and are not a substitute for certified architectural and engineering drawings, nor do they necessarily reflect national and local building code requirements. For additional information, see specifications on page 47 or call Technical Service at 800 USG.4YOU.

Curved Drywall Ceilings

Pendant fixture—vault

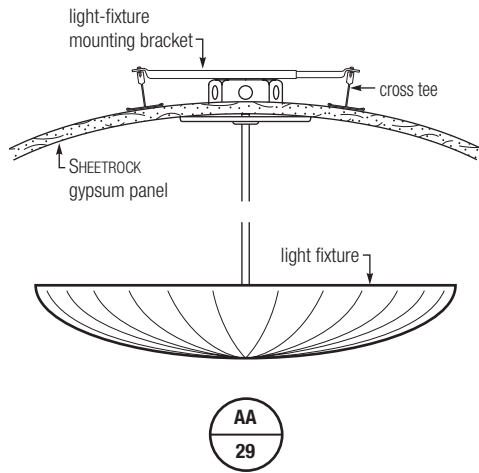

Incandescent fixture—recessed flat ceiling

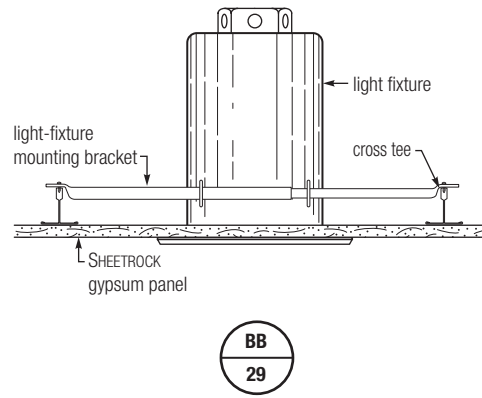

FIRE-RATED ASSEMBLIES

Flat Drywall Ceilings

Floor/Ceiling	UL Design No.	Assembly Rating*	Board Thick.	Wallboard Type	Fixture Size (% of Fixtures)	Max Duct Area, sq. in. per 100 sq. ft.	Assembly Construction Details
Concrete/Steel Deck	D501	2 HR-R 1-1/2 HR-UR 2 HR-UBR	5/8"	USG Sheetrock® Brand Firecode C	N/A	N/A	Min. 2" normal wt. concrete on min. W8x17 beams
	D502	2 HR-R & UR 2 HR-UBR	5/8"	USG Sheetrock® Brand Firecode C 1P-X2, 1PC-AR & WRC	2x4 (24%)	144 sq. in.	Min. 2-1/2" normal wt. concrete topping on min. W8x28 beams
	D503	2 HR-R & UR 2 HR-UBR	5/8"	USG Sheetrock® Brand Firecode C	69 dia. incandescent 4 per 100 sq. ft.	N/A	Min. 2-1/2" normal wt. concrete on 2" steel deck on min. W12x19 beams
Concrete/Expanded Lath Floors Over Steel Joists and Beams	G523	2 HR-R & UR 3 HR-UBR	5/8"	USG Sheetrock® Brand Firecode C 1P-X2	2x4 (24%)	144	Min. 2-1/2" normal wt. concrete topping on min. 8J2 joists and W10x21 beams
	G524	2 HR-R & UR 2 HR-UBR	1/2"	USG Sheetrock® Brand Firecode C 1P-X2, 1PC-AR & WRC	N/A	113	Min. 2-3/4" or 2-1/2" lt. wt. or normal wt. concrete topping on min. 8" or 10" Hambro joists, respectively, and min. W8x24 beams
	G525	2 HR-R & UR 2 HR-UBR	5/8"	USG Sheetrock® Brand Firecode C	N/A	113	Min. 3-1/2" or 3-1/4" normal wt. concrete topping on min. 8" or 10" Hambro joists, respectively, and W8x24 beams
	G526	2 HR-R & UR 2 HR-UBR	1/2"	USG Sheetrock® Brand Firecode C	2x4 (25%)	57	Min. 2-1/2" normal wt. concrete topping on min. 8J2 joists and W10x21 beams
	G527	2 HR-R & UR 3 HR-UBR	1/2"	USG Sheetrock® Brand Firecode C 1P-X2 & 1PC-AR	N/A	N/A	Min. 2-1/2" normal wt. concrete topping on min. 8J2 joists and W10x21 beams
	G528	1-1/2 HR-R & UR	1/2"	USG Sheetrock® Brand Firecode C	N/A	N/A	Min. 2-1/2" normal wt. concrete topping on min. 10J2 joists
	G529	2 HR-R & UR 2 or 3 HR-UBR	1/2"	USG Sheetrock® Brand Firecode C	2x4 (24%)	57	Min. 2-1/2" normal wt. or lt. wt. concrete topping on min. 10J2 joists and W8x24 beams
			1/2"	USG Sheetrock® Brand Firecode C	2x4 (24%)	57	Min. 3-1/4" normal wt. concrete topping on min. 10J2 joists and W8x24 beams
			5/8"	USG Sheetrock® Brand Firecode C	2x4 (24%)	57	Min. 2-3/4" normal wt. concrete topping on min. 10J2 joists and W8x24 beams
	G531	2 HR-R&UR 2 HR-UBR	1/2"	USG Sheetrock® Brand Firecode C	1x1 (1%)	144	Min. 3-1/4" normal wt. concrete min. 6" D500 steel joist
			5/8"	USG Sheetrock® Brand Firecode C	1x1 (1%)	144	Min. 2-1/2" normal wt. concrete min. 6" D500 steel joist
	G541	1 HR-R&UR	5/8"	USG Sheetrock® Brand Firecode C	2x4 (24%)	113	Min. 3-1/2" normal wt. concrete min. 7-3/16"-deep, 18-ga. steel C-joists
	G546	1 HR-R&UR 1 HR-UBR	5/8"	USG Sheetrock® Brand Firecode C	N/A	N/A	Min. 2" normal lt. wt. concrete light-gauge steel truss
	G547	2 HR-R&UR	1/2"	USG Sheetrock® Brand Firecode C	2x4 (24%)	114	Min. 2-1/2" normal wt. concrete min. 8J2 or 10K1 steel joists
			5/8"	USG Sheetrock® Brand Firecode C	2x4 (24%)	114	Min. 3" normal wt. concrete min. 8J2 or 10K1 steel joists
	G551	1 HR-UR	5/8" (1 or 2 layers)	USG Sheetrock® Brand Firecode C	N/A	N/A	1" USG Levelrock® Brand, steel deck, 9-1/4"-deep steel C-joists @ 24" OC, 3-1/2" insulation, RC-Is @ 24" OC
Precast Concrete Floors	J502	2 HR-U & UR 3 HR-R & UR	5/8" 5/8"	USG Sheetrock® Brand Firecode C USG Sheetrock® Brand Firecode C	NA NA	NA NA	Min. 2" normal wt. concrete slab min. 2-3/4" normal wt. concrete slab
Wood Joists	L211	2 HR-UR 75-min. finish rating	1/2"	USG Sheetrock® Brand Firecode C	1x4 (12%) 2x2 (16%) 2x4 (24%) 20"x48" (20%)	576	T & G or plywood (see 6 alternatives) over subfloor on 2x10 joists @ 16" OC, plus P237- ceiling const.
	L502	1 HR-UR 22-min. finish rating	1/2"	USG Sheetrock® Brand Firecode C 2P-X2, 1PC-AR & WRC	N/A	N/A	T & G or plywood (see 14 alternatives) over subfloor on 2x10 joists @ 16" OC
	L508	1 HR-UR 29-min. finish rating	5/8"	USG Sheetrock® Brand Firecode C 1P-X1, 2P-X2, 2PC-AR, SCX, SYX & WRX	N/A	N/A	T & G or plywood on 4x10 or DBL 2x10 joists
	L513	1 HR-UR 28-min. finish rating	5/8"	USG Sheetrock® Brand Firecode C	N/A	N/A	3/4" T & G w/ adhesive on 2x10 joists @ 24" OC, drywall battens at joints (see 15 alternatives)

Flat Drywall Ceilings

Floor/Ceiling	UL Design No.	Assembly Rating*	Board Thick.	Wallboard Type	Fixture Size (% of Fixtures)	Max Duct Area, sq. in. per 100 sq. ft.	Assembly Construction Details
	L515	1 HR-UR 21-min. finish rating	1/2"	USG Sheetrock® Brand Firecode C 2P-X2, 1PC-AR & WRC	N/A	N/A	T & G over subflooring on 2x10 joists @ 16" OC (see 9 alternatives)
	L523	1 HR-U 21-min. finish rating	5/8"	USG Sheetrock® Brand Firecode C	N/A	198	Finish floor over 5/8" plywood on 2x10 joists @ 16" OC max.
	L525	1 HR-UR 21-min. finish rating	1/2" or 5/8"	USG Sheetrock® Brand Firecode C	2x4 (24%)	57	T & G or plywood over subflooring on 2x10 joists @ 16" OC (see 12 alternatives)
	L526	1 HR-UR 22-min. finish rating	5/8"	USG Sheetrock® Brand Firecode C 1P-X2, 1PC-AR & WRC	2x4 (24%)	114	T & G or plywood over on 2x10 joists (see 10 alternatives)
Plywood with Wood Truss	L521	1 HR-U 25-min. finish rating	5/8"	USG Sheetrock® Brand Firecode C	N/A	324	Finish floor over plywood subfloor on min. 18"-deep wood truss @ 24" OC max.
	L529	1 HR-UR 22-min. finish rating	5/8"	USG Sheetrock® Brand Firecode C 1P-X2, 2PC-AR	2x4 (24%)	57	T & G wood floor or normal wt. insulating concrete over subflooring (see 16 alternatives) on trusses @ 24" OC max
	L550	1 HR-U 23-min. finish rating	5/8"	USG Sheetrock® Brand Firecode C	N/A	360	Finish floor over T&G plywood subfloor on min. 18"-deep wood truss @ 24" OC max.
Steel C-Joists or Light-Gauge Steel Truss	L524	1 HR-R&UR	1/2" (2 layers)	USG Sheetrock® Brand Firecode C	N/A	N/A	Finish floor over plywood subfloor on min. 7"-deep steel C-joist
	L548	1 HR-R&UR	5/8" (2 layers)	USG Sheetrock® Brand Firecode C	N/A	N/A	7/8" T&G plywood on min. 11-3/8"-deep, 16-ga. steel truss @ 24" OC max.
	L549	1 HR-R&UR	5/8"	USG Sheetrock® Brand Firecode C	N/A	N/A	Finish floor over 23/32" plywood on light-gauge steel trusses @ 48" OC max.
	L551	1 HR-R&UR	5/8"	USG Sheetrock® Brand Firecode C	N/A	N/A	Finish floor over 23/32" plywood on light-gauge steel trusses @ 48" OC max.
	L552	1 HR-R&UR	5/8"	USG Sheetrock® Brand Firecode C	N/A	N/A	Finish floor over 23/32" plywood on light-gauge steel trusses @ 48" OC max.
	L553	1 HR-R&UR	5/8"	USG Sheetrock® Brand Firecode C	N/A	N/A	Finish floor over 23/32" plywood on light-gauge steel trusses @ 48" OC max.
	L559	1 HR-R&UR	5/8"	USG Sheetrock® Brand Firecode C	N/A	N/A	Finish floor over 23/32" plywood on light-gauge steel trusses @ 48" OC max.
	L560	1 HR-R&UR	5/8"	USG Sheetrock® Brand Firecode C	N/A	N/A	Finish floor over 23/32" plywood on light-gauge steel trusses @ 48" OC max.
	L563	1 HR-UR	5/8"	USG Sheetrock® Brand Firecode C	N/A	256	Wood floor; 2x4 open-web wood truss @ 24" OC
	L569	1 HR-UR	5/8"	USG Sheetrock® Brand Firecode C	N/A	N/A	Wood floor; 2x10 wood joists @ 16" or 24" OC when battens (item 7) are used.
	L570	1 HR-UR	1/2"	USG Sheetrock® Brand Firecode C	N/A	N/A	Wood floor, 9-1/2"-deep wood I-joists @ 19.2" OC

* R = restrained rating
 UR = unrestrained rating
 UBR = unrestrained beam rating

FIRE-RATED ASSEMBLIES

Flat Drywall Ceilings

Floor/Ceiling	UL Design No.	Assembly Rating*	Board Thick.	Wallboard Type	Fixture Size (% of Fixtures)	Max Duct Area, sq. in. per 100 sq. ft.	Assembly Construction Details
Double Ceiling Roof Assemblies	P237	2-HR-R & UR 2-HR-UBR	1/2"	USG Sheetrock® Brand Firecode C	1x4 (12%), 2x2 (16%), 2x4 (24%), 20"x48" (20%)	576	Roof system on steel roof deck, min. fiber 8H3 or 10k1 min. @ 72" OC max.
	P239	1-1/2 HR-R & UR 1-1/2 HR-UBR	1/2"	USG Sheetrock® Brand Firecode C	1x4 (12%), 2x2 (16%), 2x4 (24%), 20"x48" (20%)	576	Roof covering of gypsum concrete over USG form board, subpurlins and 12J3 joists with W6x16 beam
	P241	2 HR-R & UR	1/2"	USG Sheetrock® Brand Firecode C	1x4 (12%), 2x2 (16%), 2x4 (24%), 20"x48" (20%)	576	Roof covering over insulating concrete on steel roof deck and 10J3 min. joists @ 48" OC
Mineral and Fiber Board on Building Units or Precast Concrete	P501	1 and 2 HR-R & UR	5/8"	USG Sheetrock® Brand Firecode C 2P-X2 & 2PC-AR	N/A	N/A	Roof covering over mineral and fiber board on building or precast concrete units, 14J5 joists @ 48" OC max.
Gypsum Plank, Insulation Board	P506	1-1/2 HR-R & UR	5/8"	USG Sheetrock® Brand Firecode C	2x4 (24%)	57	Roof covering over min. & fiber boards on gypsum planks, subpurlins and 12 H5 joists @ 48" OC max.
	P508	1 HR-R & UR	5/8"	USG Sheetrock® Brand Firecode C 2P-X2, 1PC-AR & WRC	2x4 (24%)	144	Roof covering over min. & fiber boards (see alt) gyp wallboard, steel roof deck, 10J4 joists (min.) @ 48" OC
Insulating Concrete	P507	1-1/2 HR-R 1 HR-UR	5/8"	USG Sheetrock® Brand Firecode C	2x4 (24%)	57	Roof covering on foamed plastic insulation, Gypsum conc and form boards on subpurlins and 10J4 joists (min.) @ 4' OC
	P509	1 HR-R & UR 1 HR-R	5/8"	USG Sheetrock® Brand Firecode C	2x4 (24%)	144	Roof covering on foamed plastic insulation, Gypsum conc and form boards on subpurlins and 10J4 joists (min.) @ 4' OC
Corrugated Steel Deck with Insulated Board or Foam Plastic Insulation	P510	1 & 1-1/2 HR-R & UR	1/2" & 5/8"	USG Sheetrock® Brand Firecode C	2x4 (24%)	57	Roof covering over insulation (see alt) on gypsum wallboard steel roof deck, 10J4 joists (min.) @ 72" OC max.
	P513	1-1/2 HR-R & UR	5/8"	USG Sheetrock® Brand Firecode C	2x4 (24%)	144	Roof covering on insulating concrete and foamed plastic over corrugated steel deck, 10J4 steel joists @ 48" OC
	P514	2 HR-R & UR	5/8"	USG Sheetrock® Brand Firecode C	2x4 (24%)	255	Roof covering over insulation (see 9 alternatives), gyp. wallboard and steel deck, 8H3 steel joists @ 48" OC
	P516	1 HR-UR	5/8" (2 layers)	USG Sheetrock® Brand Firecode C	N/A	N/A	Metal roof deck panels on min. 8"-deep C- or Z-shaped purlins @ 60" max., glass fiber insulation between roof deck panels and steel roof purlins, W-shaped beam
	P518	1 HR-R&UR 1 HR-UB	1/2" (2 layers)	USG Sheetrock® Brand Firecode C	N/A	N/A	Roof covering over steel deck on min. 8"-deep, 18-ga. steel C-joists @ 24" OC max.
Engineered Steel or Wood Roof Truss	P515	1 HR-R&UR	5/8" (2 layers)	USG Sheetrock® Brand Firecode C	N/A	N/A	Roof covering over mineral and fiber board on steel roof deck over steel roof trusses @ 48" OC max.
	P521	2 HR-R&UR	5/8" (2 layers)	USG Sheetrock® Brand Firecode C	N/A	N/A	Roof covering over foamed plastic insulation, gypsum wallboard, steel deck on light-gauge steel trusses @ 48" OC max.
	P522	1 HR-UR	5/8"	USG Sheetrock® Brand Firecode C	N/A	196	Roof system over 15/32" plywood on wood trusses @ 24" OC max.
	P523	1 HR-R&UR	5/8"	USG Sheetrock® Brand Firecode C	N/A	N/A	Roof system over 23/32" plywood on light-gauge steel trusses @ 48" OC max.

Flat Drywall Suspension Ceilings

Floor/Ceiling	UL Design No.	Assembly Rating*	Board Thick.	Wallboard Type	Fixture Size (% of Fixtures)	Max Duct Area, sq. in. per 100 sq. ft.	Assembly Construction Details
Engineered Steel or Wood Roof Truss	P525	2 HR-R&UR	5/8" (2 layers)	USG Sheetrock® Brand Firecode C	N/A	N/A	Roof membrane or metal roof deck on foamed plastic insulation, USG Durock® Brand Cement Board or gypsum wallboard over corrugated steel deck on light-gauge steel trusses @ 48" OC max.
	P526	1 HR-R&UR	5/8"	USG Sheetrock® Brand Firecode C	N/A	N/A	Roof system over 23/32" plywood or steel roof deck on light-gauge steel trusses @ 48" OC max.
	P527	1-1/2 HR-R&UR	5/8"	USG Sheetrock® Brand Firecode C	N/A	N/A	Roof covering or metal roof deck on foamed plastic insulation, USG Durock® Brand Cement Board or gypsum wallboard over corrugated steel deck on light-gauge steel trusses @ 48" OC max.
	P528	1 HR-R&UR	5/8"	USG Sheetrock® Brand Firecode C	N/A	N/A	Roof system over 23/32" plywood or steel roof deck on light-gauge steel trusses @ 48" OC max.
	P529	1-1/2 HR-R&UR	5/8"	USG Sheetrock® Brand Firecode C	N/A	N/A	Roof covering or metal roof deck on foamed plastic insulation, USG Durock® Brand Cement Board or gypsum wallboard over corrugated steel deck on light-gauge steel trusses @ 48" OC max.
	P530	1 HR-R&UR	5/8"	USG Sheetrock® Brand Firecode C	N/A	N/A	Roof system over 23/32" plywood or steel roof deck on light-gauge steel trusses @ 48" OC max.
	P531	1 HR-UR	5/8"	USG Sheetrock® Brand Firecode C	N/A	360	Roof system over 15/32" plywood on wood trusses @ 24" OC max.
	P534	1 HR-R&UR	5/8"	USG Sheetrock® Brand Firecode C	N/A	N/A	Roof system over 23/32" plywood or steel roof deck on light-gauge steel trusses @ 48" OC max.
	P535	1 HR-R&UR	5/8"	USG Sheetrock® Brand Firecode C	N/A	N/A	Roof covering or metal roof deck over mineral and fiber board or foamed plastic insulation, USG Durock® Brand Cement Board or gypsum wallboard over light-gauge steel trusses @ 48" OC max.
	P536	2 HR-R&UR	5/8" (2 layers)	USG Sheetrock® Brand Firecode C	N/A	N/A	Roof covering or metal roof deck on foamed plastic insulation, USG Durock® Brand Cement Board or gypsum wallboard over corrugated steel deck on light-gauge steel trusses @ 48" OC max.
	P537	1 HR-R&UR	5/8"				Roof system over 23/32" plywood or steel roof deck on light-gauge steel trusses @ 48" OC max.

Fire-Rated Butt Joint Cross-Tee Spacing

Fire-rated ceilings require extra cross tees spaced 8" or less on either side of the butt joint. Fire-rated assemblies require a hanger wire installed adjacent to fire-relief notch.

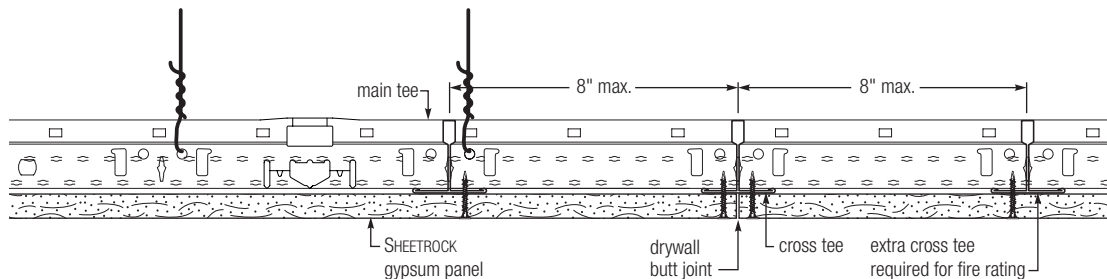

EXTERIOR APPLICATION WIND LOAD DATA

USG has a selection of Drywall Suspension assemblies to accommodate the wind loads for most applications. The system has been tested using applicable industry standards for wind uplift resistance when installed in exterior soffits and canopies. For more detailed information regarding constructing exterior soffits, please refer to systems guide USG Exterior Ceilings Applications, SC2156.

Only USG Sheetrock® Brand exterior ceiling board, USG Durock® Brand cement board and USG Sheetrock® Brand Glass Mat Sheathing are suitable for exterior applications. Specific information for gypsum panel applications can be found at usg.com and usgdesignstudio.com.

Design wind loads vary with geographic region and building conditions and must be established by a professional engineer or architect of record.

Flat Drywall Ceiling

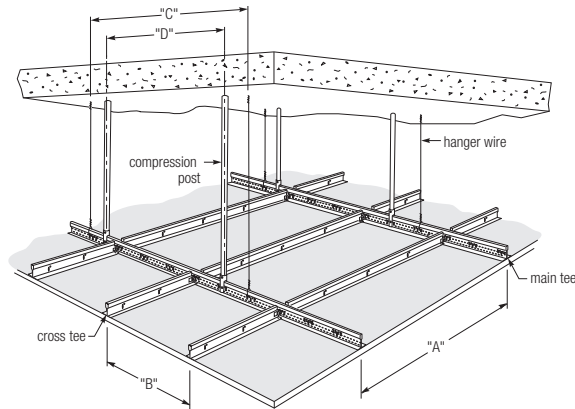

Test Record	UL Class	Max. Uplift Load (psf)	Equivalent Wind Speed (mph)	Component Spacing				Exterior Soffit Panels	Plenum Height ¹ (in.)	Max. Compression Post Load (lbs.)	Test Standard
				(A) Main Runner	(B) Cross Tee	(C) 12-Gauge Hanger Wire	(D) Compression Post				
UL526	15	15	77	48	24	24	24	single-layer 5/8" gypsum panels	141	183.2	UL 580
UL526A, B	15	15	77	48	16 (526A) 24 (526B)	48	30	single-layer 1/2" gypsum panels	128	229	UL 580
UL526C	30	30	108	24	24	48	30	single-layer 1/2" gypsum panels	130	225	UL 580
UL526D	60	60	188	24	24	48	42	double-layer 5/8" gypsum panels	76	525	UL 580
UL526E	90	90	188	24	24	48	30	double-layer 5/8" gypsum panels	76	525	UL 580
UL526F	90	90	188	24	16	48	24	single-layer 5/8" gypsum panels, single layer 3/8" plywood	76	525	UL 580
NOA No. 12-0924.03	N/A	+75, -75	171	24	16	24	24	single-layer 1/2" or 5/8" glass mat sheathing w/direct applied EFIS	24	300	TAS 202, TAS 203

¹ Larger plenum heights require compression post size and gauge to be determined by a qualified structural engineer.

SEISMIC REQUIREMENTS

Flat Ceilings Exemptions

Flat ceilings constructed of gypsum board that are screw-attached to suspension members that support a ceiling on one level extending from wall to wall are generally exempt from acoustical seismic construction requirements such as the following: perimeter end wall clearance, perimeter hanger wires, horizontal restraint and vertical splay bracing; see ASTM E580. This is due to the diaphragm strength achieved by screw-attached gypsum board. In addition, there are no lay-in ceiling panels that can become dislodged.

	IBC Category D, E, F	IBC Category C
Minimum intersection strength limits for MT/CT	180 lbs.	60 lbs.
Vertical 12-gauge hanger-wire	Required	Required
Main-tee classifications	No min. requirement	No min. requirement
Perimeter vertical hanger wires not more than 8 in. from wall	Not required	Not required
Grid end/wall clearance	Not required	Not required
Perimeter closure (molding) width	No min. requirement	No min. requirement
Perimeter tee ends tied together at perimeters	Not required	Not required
Horizontal restraint (splay wires or rigid bracing) within 2 in. of intersection and splayed 90° apart at 45° angles	Not required	Not required
Compression posts (struts) 12 ft. OC in both directions, starting 6 ft. from walls	Not required	Not required
Supplementary light fixture attachment	Not required	Not required
Seismic separation joint	Not required	Not required
Drywall control joint	Required when applicable	Required when applicable

Curved Ceilings

1. Areas using curved main tees with radii 7' or larger should use seismic splay wires and compression posts 12' OC similar to the CISCA Guidelines for Seismic Restraint for Direct-Hung Suspended Ceiling Assemblies. See the illustration below for details.
2. Areas using curved main tees with radii smaller than 7' require bridging members, such as USG Donn® Brand DXW main tees, which span across the curved drywall main tees. These bridging tees are screw fastened to "hard" points in the curved drywall ceiling, such as the tops of vaults. Seismic splay wires and compression posts are then fastened to the bridging members.
3. Seismic restraint is usually accomplished with a set of four "splay" wires and a compression post. The wires run parallel to the main tees and cross tees at an angle of less than, or equal to, 45° to the horizontal. The compression post is installed at the junction of the four "splay" wires. This post must be strong enough to resist any uplift forces generated during an earthquake. The type of post needed also varies with the depth of the plenum. Compression posts must be approved by the project engineer or the architect of record to ensure they will resist the uplift forces. Call Technical Service for details. Seismic restraints must be installed at a minimum distance of 12' OC.

Interior Ceiling

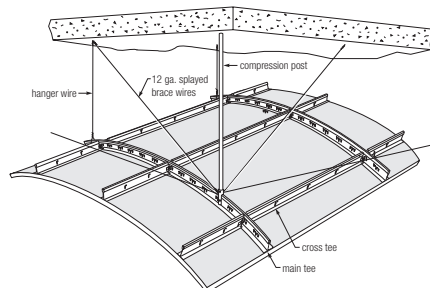

APPLICATION GUIDE SPECIFICATIONS

Flat Drywall Ceilings

1: General

1.01 Related Work

- A.** Related work specified elsewhere:
- 1.** Gypsum Board: Section _____
 - 2.** Air Handling: Section _____
 - 3.** Lighting: Section _____
 - 4.** Acoustical: Section _____
- B.** Work installed but furnished under other sections: _____
- C.** Work installed but furnished under other sections: _____

1.02 System Description

- A.** A pre-engineered Drywall Suspension System consisting of straight main tees along with straight furring cross channels or cross tees, which join together to support screw-attached gypsum panels, independently supported light fixtures and air diffusers, where applicable. Where applicable, installed systems must conform to Underwriters Laboratories, LLC (UL) Fire Resistance Design No. and other applicable codes.

1.03 Quality Assurance

- A.** Subcontractor qualification: Installer shall have successful experience installing suspension and drywall systems.
- B.** Requirements of regulatory agencies: Codes and regulations of authorities having jurisdiction.
- C.** Source quality control: Manufacturer will provide test certification for suspension systems as required to meet performance standards specified by various agencies.

1.04 References

- A.** ASTM C635, Standard Specifications for Metal Suspension Systems
- B.** ASTM C636, Recommended Practice for Installation of Metal Suspension Systems
- C.** ASTM A653, Standard Specification for Steel Sheet, Zinc-Coated (Galvanized) or Zinc-Iron Alloy-Coated (Galvannealed) by the Hot-Dip Process
- D.** CISCA Ceiling Systems Installation Handbook
- E.** GA 216, Installation & Finish of Gypsum Panels
- F.** ASTM C645, Standard Specification for Non-Structural Steel Framing Members
- G.** ASTM C754, Specification for Installation of Steel Framing Members to Receive Screw-Attach Gypsum Boards
- H.** ASTM C843, Specification of Application of Gypsum Veneer Plaster
- I.** ASTM C844, Specification of Application of Gypsum Base to Receive Veneer Plaster
- J.** ASTM E119, Standard Test Methods for Fire Tests of Building Construction and Materials
- K.** Underwriters Laboratories, LLC (UL) Fire Resistance Directory
- L.** ASTM E580, Standard Practice for Application of Ceiling Suspension Systems for Acoustical Tile and Lay-in Panels in Areas Requiring Seismic Restraint
- M.** CISCA Recommendations for Direct-Hung Acoustical Tile and Lay-In Panel Ceilings, Seismic Zones 0-2
- N.** CISCA Guidelines for Seismic Restraint for Direct-Hung Suspended Ceiling Assemblies, Seismic Zones 3-4
- O.** ASTM C1396, Standard Specification for Gypsum Wallboard
- P.** ASTM C1002, Standard Specification for Steel Self-Piercing Tapping Screws for the Application of Gypsum Panel Products or Metal Plaster Bases to Wood Studs or Steel Studs

1.05 Submittal

- A.** Samples: Submit actual samples and technical data for suspension system main tees and cross tees for review.
- B.** Shop Drawings:
- 1.** Reflected ceiling plans: Submit ceiling suspension system layout indicating dimensions, lighting fixture locations and related mechanical components.
 - 2.** Assembly drawings: Indicate installation details, accessory attachments, and installation of related lighting fixtures and related mechanical system components.
- C.** Manufacturer's Data:
- 1.** System details: Submit manufacturer's catalog cuts or standard drawing showing details of system with project conditions clearly identified and manufacturer's recommended installation instructions.

Flat Drywall Ceilings

1.06 Delivery, Storage and Handling

- A. Delivery of materials: Deliver materials in original, unopened packages clearly labeled with a manufacturer's name, item description, part number, type and class, as applicable.
- B. Inspection: Promptly inspect delivered materials, file freight claims for damage during shipment and order replacement of materials as required. Any damaged materials should be promptly removed from the job site.
- C. Storage: Store in a manner that will prevent warpage, water damage or damage of any kind. Prevent interference to/by other trades and any other adverse job conditions due to storage locations or methods.
Warning: Store all USG Sheetrock® Brand Gypsum Panels flat. Panels are heavy and can fall over, causing serious injury or death. Do not move unless authorized.
- D. Handling: Handle in such a manner to prevent racking, distortion or physical damage of any kind.

1.07 Project Conditions

- A. Existing conditions: (include specific alteration work requirements for the project).
- B. Environmental requirements:
 - 1. Building Conditions: Building shall be enclosed with all windows and exterior doors in place and glazed, and roof watertight before installation of suspension system.
 - 2. Interior temperature/humidity in building: Conditions in areas to receive Drywall Suspension Systems shall range from 60° F (16° C) to 104° F (40° C) and relative humidity of not more than 90% shall be maintained before installation of components.
 - 3. In cold weather during gypsum panel installation and joint-finishing and veneer-plaster application, temperatures within the building shall be maintained in the range of 55-70° F (13-21° C). Heat and ventilation should be evenly provided to facilitate curing and drying.
- C. Coordination with other work:
 - 1. General: Coordinate with other work supported by or penetrating through the ceiling, including mechanical and electrical work and partition systems.
 - 2. Mechanical work: Ductwork above system shall be complete and permanent HVAC systems operating.
 - 3. Electrical Work: Installation of conduit above suspension system shall be complete before installation of suspension system.
- D. Protection:
 - 1. Personnel: Follow good safety and industrial hygiene practices during handling and installing of all products and systems, with personnel taking necessary precautions and wearing appropriate personal protective equipment as needed. Read material safety data sheets and related literature for important information on products before installation. Contractor to be solely responsible for all personal safety issues during and subsequent to installation. Architect, specifier, owner and manufacturer will rely on contractor's performance in these matters.

2: Products

2.01 Manufacturer

- A. USG Drywall Suspension System.
- B. USG Sheetrock® Brand gypsum products, panels and accessories (regular, lightweight, Firecode, Firecode C). See *Gypsum Products: Panels and Accessories* (SA92) for specifications.
- C. USG Sheetrock® Brand joint tape, joint compounds, trim, and accessories. See *USG Sheetrock® Brand Interior Finishing Products* (J1424) for specifications.
- D. USG Imperial® Brand gypsum base. See (SA920) for specification. All manufactured by USG, Chicago, IL USA. Manufactured in accordance with ASTM C588, Standard Specification for Gypsum Base for Veneer Plasters.
- E. USG Fiberock® Brand Aqua-Tough™ interior panels. See *Moisture-Resistant Assemblies* (SA934) for specifications.
- F. USG Durock® Brand cement board. See *Moisture-Resistant Assemblies* (SA934) for specifications.

APPLICATION GUIDE SPECIFICATIONS

Flat Drywall Ceilings

2.02 Materials

- A. Commercial-quality, cold-rolled steel, hot-dipped galvanized finish
- B. USG Flat Drywall Suspensions Systems:
 - 1. Main Tees: Fire-Rated Heavy Duty classification, 144" long, with integral reversible splice with knurled face.
DGLW26 1-1/2" Face, 1.617" high
or
DGL26 15/16" Face, 1-1/2" high
 - 2. Cross Members: Fire-Rated members with knurled face.
Cross Tees: DGLW424 cross-tee 1-1/2" high x 48" long with 1-1/2" wide face. Tees must have quick-release cross-tee ends to provide positive locking and removability without the need for tools.
or
Furring Channel: DGCL-4 furring channel 7/8" high x 48" long with 1-1/2" face.
 - 3. Accessory Cross Tees: Cross tees must have knurled faces. Cross tees have quick-release cross-tee ends to provide positive locking and removability without the need for tools.
DGL224 Fire-Rated 1-1/2" high x 24" long with 15/16" face
DGL424 Fire-Rated 1-1/2" high x 48" long with 15/16" face
DGLW224 Fire-Rated 1-1/2" high x 24" long with 1-1/2" face
DGLW424 Fire-Rated 1-1/2" high x 48" long with 1-1/2" face
DGLW624 Fire rated 1-1/2" high x 48" long with 1-1/2" face
 - 4. Wall moldings: Single web with knurled face.
DGWM24 1"x 1-1/2" x 144" long wall molding
DGCM27 144"x 1-5/8"x 1"channel molding
- C. Accessories
 - 1. Transition clip DGTC-90
 - 2. Splice clip DGSC-180
 - 3. Wall attachment clip DGWC
 - 4. Splice plate DGSP
 - 5. Dome hub DGHUB
 - 6. Compásso drywall clip DGC4, DGC6, DGC8
- D. USG Compásso trim
 - 1. 4" Compásso trim: 4" wide face, 9/16" horizontal legs with hems formed for attachment to the Compásso mounting clip, commercial-quality cold-rolled 24-gauge steel with factory finish.
 - 2. 6" Compásso trim: 6" wide face, 9/16" horizontal legs with hems formed for attachment to the Compásso mounting clip, commercial-quality cold-rolled 24-gauge steel with factory finish.
 - 3. 8" Compásso trim: 8" wide face, 9/16" horizontal legs with hems formed for attachment to the Compásso mounting clip, commercial-quality cold-rolled 24-gauge steel with factory finish.
 - 4. 10" Compásso trim: 10" wide face, 9/16" horizontal legs with hems formed for attachment to the Compásso mounting clip; commercial-quality cold-rolled 24-gauge steel with factory finish.
 - 5. 12" Compásso trim: 12" wide face, 9/16" horizontal legs with hems formed for attachment to the Compásso mounting clip; commercial-quality cold-rolled 24-gauge steel with factory finish.
- E. Gypsum panels
 - 1. Gypsum panels manufactured in accordance with ASTM C36.
 - 2. 1/4", 3/8", 1/2", 5/8" and 3/4" USG Sheetrock® Brand or USG Securock® Brand gypsum panels (Regular, Firecode, Firecode C)
- F. USG Sheetrock® Brand drywall accessories: trims, expansion joints, sealants, joint compound materials (see USG Gypsum Panels & Accessories Specifications SA927 09250)

Flat Drywall Ceilings

	2.03 Metal, Paper or Plastic Trim	<p>A. Corner Reinforcement: Minimum #26 gauge, zinc alloy with or without paper flanges or plastic bead.</p> <p>B. Casing Reinforcement: Minimum #24 gauge, zinc alloy or plastic with expanded flanges.</p> <p>C. Control Joints: Minimum #26 gauge, zinc alloy .093, extruded aluminum or plastic with expanded flanges.</p>
	2.04 Fasteners	<p>A. Conventional Gypsum Panel fasteners (ASTM C1002): No. 6 Type-S, HiLo bugle head, self-drilling, self-tapping steel screws.</p>
3: Execution	3.01 Inspection	<p>A. Examine areas to receive materials for conditions that will adversely affect installation. Provide written report of unacceptable surface.</p> <p>B. Do not start work until unsatisfactory conditions are corrected.</p> <p>C. Work to be concealed: Verify work above ceiling suspension system is complete and installed in manner that will not affect layout and installation of suspension system components.</p> <p>D. Beginning of installation shall signify acceptance of conditions in areas to receive ceiling suspension system.</p> <p>F. Fire-rating requirements: Construction above fire-rated assembly shall meet requirements as applicable to provide fire-resistance rating specified above in Part 2-Products.</p>
	3.02 Preparation	<p>A. Field dimensions must be verified prior to installation.</p>
	3.03 Installation	<p>A. Standard reference: Install in accordance with ASTM C636, CISCA installation standards and other applicable code references.</p> <p>B. Manufacturer's reference: Install in accordance with manufacturer's current printed recommendations.</p> <p>C. Drawing reference: Install in accordance with approved shop drawings and locate ceiling in accordance with main-tee dimensions relative to elevations.</p> <p>D. Component and hanger-wire installation: Flat Ceilings: Main tees shall be spaced a maximum of 48" or 72" on center depending on cross-tee layout selected and supported by hanger wires spaced a maximum 48" on center or as specified by UL Fire Resistance Directory, attaching hanger wires directly to structure above. Cross tees shall be spaced per recommendations and/or as specified by UL Fire Resistance Directory. Transitions: Changes in Elevation in Soffit and Fascia Ceiling Applications. When constructing stepped soffits, bracing of the Drywall Suspension System and/or additional hanger wires may be necessary to ensure stability and structural performance during and after drywall attachment. The maximum vertical soffit height is 48". (Maximum unsupported drywall area shall not exceed 48"x 24"). Intermediate cross tees are not necessary when soffit dimensions do not exceed 24". Cross-tee spacing in horizontal soffit plane is not to exceed 24". Intermediate cross tees may be necessary to maintain visually acceptable drywall planes and drywall corners. General hanger wire notes: Hanger wires are required within 12" on both sides of a pivoted splice clip. At least 1 hanger wire is required within 12" of a transition clip. Limitations: Do not support wires from mechanical and/or electrical equipment occurring above ceiling.</p> <p>E. Accessories: Install accessories as applicable to meet project requirements.</p>

APPLICATION GUIDE SPECIFICATIONS

Flat Drywall Ceilings

3.04 Gypsum Panel Installation

- A. Apply gypsum panels first to ceiling and then to walls. Position all ends and edges of gypsum panels at framing members. Extend ceiling board to corners and make firm contact with the wall angle, channel or top plate. To minimize end joints, use panels of maximum practical lengths. Fit ends and edges closely, but do not force together.
- B. Cut ends and edges, scribe or make cutouts within the field of panels in a workmanlike manner. Cut gypsum board to size using a knife and straight edge.
- C. Attach gypsum panels to the suspension system main runners, cross tees and cross channels with conventional gypsum panel fasteners (No. 6 Type S HiLo bugle head, self-drilling, self-tapping steel screws) spaced 8" OC at periphery of gypsum panels and located 3/8" in from panel edges and spaced 12" OC in the field. Drive fasteners in field of panels first, working toward ends and edges. Hold panels in firm contact with framing while driving fasteners. Drive fastener heads slightly below surface of gypsum panels without breaking face paper. (See Gypsum Panel and Accessories Specification SA927 09250.) Install trim at all internal and external angles formed by the intersection of panel surfaces or other dissimilar materials. Apply corner reinforcement to all vertical or horizontal external corners in accordance with directions.

Ceilings note:

Spacing of drywall grid is designed to support only the dead load. Heavy, concentrated loads should be independently supported. Lighting fixtures or troffers, air vents and other equipment should be separately supported from the structure; gypsum panels will not support these items.

To prevent objectionable sag in new gypsum panel ceilings, the weight of overlaid unsupported insulation should not exceed 1.3 psf for 1/2" thick gypsum panels with spacing of 24" OC; 2.2 psf for 1/2" thick gypsum panels 16" OC framing and 1/2" USG Sheetrock® Brand UltraLight panels on 24" OC framing and 5/8" panels 24" OC; 3/8" thick gypsum panels must not be overlaid with unsupported insulation. A vapor retarder should be installed in exterior ceilings, and plenum or attic spaces should be properly vented.

During periods of cold or damp weather when a polyethylene vapor retarder is installed on ceilings behind the gypsum panels, it is important to install the ceiling insulation before or immediately after installing the gypsum panels. Failure to follow this procedure may result in moisture condensation in the back of the gypsum panels, causing sag.

- E. Spray-Textured Ceilings: Where water-based texturing materials or any slow-drying surface treatment is used over single-layer panels, maximum frame spacing is 16" OC for standard 1/2" panels applied perpendicular to framing, 24" for 1/2" USG Sheetrock® Brand UltraLight Panels.

3.05 Expansion Joints

- A. Provide a separation in the suspension system at expansion joints as shown on the drawings and carry the joint through the gypsum panels. Expansion joints are installed to separate the suspension system and allow for movement in large ceiling areas.

3.06

- A. Provide control joint No. 093, which has a 3/32" groove for drywall and veneer plaster. Ceiling areas should not exceed 2,500 sq. ft. with perimeter relief or 900 sq. ft. without perimeter relief.

Note to specifier: The following specification for USG Ceiling Suspension products and plaster products is a guide for specifying a plastered dome composed of a finished curved surface having single radius of curvature. Delete such items that are not related to the particular project. Where blank spaces are provided, insert information pertinent to the project for which the specification is prepared.

Domes

1: General

1.01 Scope	Specify areas to receive these systems.
1.02 Related Work	<p>Related work specified elsewhere:</p> <ol style="list-style-type: none"> 1. Air Handling: Section _____ 2. Lighting: Section _____ 3. Acoustical: Section _____
1.03 System Description	A pre-engineered Drywall Suspension System consisting of curved suspension grid that joins together to support screw attached metal lath, with an application of high-strength conventional plaster, forming curved domes.
1.04 Quality Assurance	<ol style="list-style-type: none"> A. Subcontractor qualification: Installer shall have successful experience installing suspension and plaster systems. B. Requirements of regulatory agencies: Codes and regulations of authorities having jurisdiction. C. Source quality control: Manufacturer will provide test certification for suspension systems as required to meet applicable industry standards and/or standards specified by various agencies.
1.05 References	<ol style="list-style-type: none"> A. ASTM C636, Recommended Practice for Installation of Metal Suspension Systems B. CISCA Ceiling Systems Installation Handbook C. ASTM C28, Specification for Gypsum Plasters D. ASTM C847, Specification for Metal Lath E. ASTM C841, Specification for Installation of Interior Lathing & Furring F. ASTM C842, Specification for Application of Interior Gypsum Plaster
1.06 Submittals	<ol style="list-style-type: none"> A. Shop Drawings: <ol style="list-style-type: none"> 1. Reflected ceiling plans: Submit ceiling suspension system layout indicating dimensions, hanger wires, lighting fixture locations and related mechanical components. 2. Assembly drawings: Indicate installation details, accessory attachments, and installation of related lighting fixtures and related mechanical system components. B. Manufacturer's Data: <ol style="list-style-type: none"> 1. System Details: Submit manufacturer's catalog cuts or standard drawing showing details of system with project conditions clearly identified and manufacturer's recommended installation instructions.
1.07 Delivery, Storage and Handling	<ol style="list-style-type: none"> A. Delivery of Materials: Deliver materials in original, unopened packages clearly labeled with a manufacturer's name, item description, part number and type class, as applicable. B. Inspection: Promptly inspect delivered materials, file freight claims for damage during shipment and order replacement materials as required. Any damaged materials shall be promptly removed from the job site. C. Storage: Store in a manner that will prevent water damage or damage of any kind. Prevent interference to/by other trades and any other adverse job conditions due to storage locations or methods. Warning: Store all USG Sheetrock® Brand gypsum panels flat. Panels are heavy and can fall over, causing serious injury or death. Do not move unless authorized. D. Handling: Handle in such a manner to prevent racking, distortion or physical damage of any kind.

APPLICATION GUIDE SPECIFICATIONS

Domes

1.08 Project Conditions

- A. Environmental Requirements:
 1. Building Conditions: Building shall be enclosed, with all windows and exterior doors in place and glazed and roof watertight before installation of suspension system and plaster.
 2. Temperatures within the building shall be maintained in the range of 55-70° F (13-21° C). Heat and ventilation shall be evenly provided to facilitate drying.
- B. Coordination with Other Work:
 1. General: Coordinate with other work supported by or penetrating through the dome, including mechanical and electrical work.
 2. Mechanical work: Ductwork above system shall be complete and permanent HVAC systems operating.
 3. Electrical work: Installation of conduit above suspension system shall be complete before installation of suspension system
- C. Protection: Follow good safety and industrial hygiene practices during handling and installing of all products and systems, to take necessary precautions and wearing appropriate personal protective equipment as needed. Read Material Safety Data Sheets and related literature for important information on products before installation. Contractor to be solely responsible for all personal safety issues during and subsequent to installation; architect, specifier, owner and manufacturer will rely on contractor's performance in these matters.

2: Products

2.01 Materials

- A. USG Drywall Suspension System
 - B. Structo-Base® gypsum plaster
 - C. Structo-Gauge® gauging plaster
 - D. USG Red-Top® Brand finish plaster
 - E. Diamond® interior finish plaster
- All manufactured by USG, Chicago, IL, USA, in compliance with ASTM Standards.
- F. Factory-curved, 1-1/2" x 1-1/2" USG drywall grid with knurled face—commercial-quality, cold-rolled steel, hot-dipped galvanized finish. Cross-tee holes spaced 8" OC
Manufacturer's designation DGW__VT__
 - G. Wire
 1. Hanger wire-12 gauge, 8 gauge, galvanized
 2. Tie wire-18 gauge, galvanized
 - H. Metal lath: 3.4 #/S.Y. self-furring diamond mesh lath, galvanized
 - I. Screws-Self-tapping truss-head lathing screws
 - J. Gypsum plaster: Structo-Base gypsum plaster
 - K. Sand: ASTM C35
 - L. Water: Clean and potable
 - M. Finish plaster: To be determined
 - N. Dome hub and connecting clips
 - O. Casing and corner beads as required
 - P. Accessories as applicable to project requirements

Domes

3: Execution

3.01 Inspection

- A. Examine areas to receive materials for conditions that will adversely affect installation. Provide written report of unacceptable surface.
- B. Do not start work until unsatisfactory conditions are corrected.
- C. Work to be concealed: Verify work above ceiling suspension system is complete and installed in manner that will not affect layout and installation of suspension system components.
- D. Beginning of installation shall signify acceptance of conditions in areas to receive ceiling suspension system.
- E. Field dimensions must be verified prior to installation.

3.02 Installation

- A. Standard reference: Install grid members in accordance with ASTM C636.
- B. Follow CISCA installation standards or other applicable code or manufacturer's references.
- C. Manufacturer's reference: Install in accordance with manufacturer's current printed recommendations.
- D. Drawing reference: Install in accordance with approved shop drawings and locate ceiling in accordance with main-tee dimensions relative to elevations.
- E. Hanger Wire Installation: Hanger wires are required along the radial suspension members (spokes) spaced no more than 32" as measured along the arc of the member. Install additional hanger wires to upper structural elements. Do not support hangers from mechanical and/or electrical equipment.
- F. Space radial spoke members so as not to exceed 48" spacing at any point.
- G. Space cross-tee members so the maximum span of metal lath is 16".
- H. Secure metal lath to tee members with screws spaced 6" OC max., applied at lath ribs. Lap metal lath ends and edges and secure with 18-gauge tie wire spaced 6" OC
- I. Mix Structo-Base® gypsum plaster with sand in proportions of 2 cu. ft. of sand per 100 lbs. of plaster for scratch and brown coats. Apply plaster to metal lath to a thickness of 5/8" (min.) Measure from the face of the lath.
- J. Select a plaster mix for the finish coat to provide a smooth trowel or sand float (textured) finish (Reference SA 920).
- K. Use template(s) to ensure uniform and even curvature of the finished surface.

Note to specifier: The following specification for the USG Drywall Suspension System is a guide for specifying curved drywall ceilings. Delete such items that are not related to the particular project. Where blank spaces occur, provide information to the particular project for which the specification is prepared.

APPLICATION GUIDE SPECIFICATIONS

Curved Drywall Ceilings

1: General

1.01 Related Work

- A. Related work specified elsewhere:
1. Gypsum Board: Section _____
 2. Air Handling: Section _____
 3. Lighting: Section _____
 4. Acoustical: Section _____
- B. Work installed but furnished under other sections: _____
- C. Work installed but furnished under other sections: _____

1.02 System Description

- A. A pre-engineered Drywall Suspension System consisting of straight and curved main tees along with straight furring cross channels or cross tees, which join together to support screw attached gypsum panels and independently supported light fixtures, and air diffusers, where applicable. Where applicable, installed systems must conform to Underwriters Laboratories, LLC (UL) Fire Resistance Design No. and other applicable codes.

1.03 Quality Assurance

- A. Subcontractor qualification: Installer shall have successful experience installing suspension and drywall systems.
- B. Requirements of regulatory agencies: Codes and regulations of authorities having jurisdiction.
- C. Source quality control: Manufacturer will provide test certification for suspension systems as required to meet performance standards specified by various agencies.

1.04 References

- A. ASTM C635, Standard Specifications for Metal Suspension Systems
- B. ASTM C636, Recommended Practice for Installation of Metal Suspension Systems
- C. CISCA Ceiling Systems Installation Handbook
- D. GA 216, Installation & Finish of Gypsum Panels
- E. ASTM C645, Standard Specification for Non-Structural Steel Framing Members
- F. ASTM C754, Specification for Installation of Steel Framing Members to Receive Screw-Attach Gypsum Boards
- G. ASTM C843, Specification of Application of Gypsum Veneer Plaster
- H. ASTM C844, Specification of Application of Gypsum Base to Receive Veneer Plaster
- I. ASTM E119, Standard Test Methods for Fire Tests of Building Construction and Materials
- J. Underwriters Laboratories Inc. (UL) Fire Resistance Directory

1.05 Submittal

- A. Samples: Submit actual samples and technical data for suspension system main tees and cross tees for review.
- B. Shop drawings:
1. Reflected ceiling plans: Submit ceiling suspension system layout indicating dimensions, lighting fixture locations and related mechanical components.
 2. Assembly drawings: Indicate installation details, accessory attachments, and installation of related lighting fixtures and related mechanical system components.
- C. Manufacturer's Data:
1. System details: Submit manufacturer's catalog cuts or standard drawing showing details of system with project conditions clearly identified and manufacturer's recommended installation instructions.

Curved Drywall Ceilings

1.06 Delivery, Storage and Handling

- A. Delivery of materials: Deliver materials in original, unopened packages clearly labeled with a manufacturer's name, item description, part number, type and class as applicable.
- B. Inspection: Promptly inspect delivered materials, file freight claims for damage during shipment and order replacement of materials as required. Any damaged materials shall be promptly removed from the job site.
- C. Storage: Store in a manner that will prevent warpage, water damage or damage of any kind. Prevent interference to/by other trades and any other adverse job conditions due to storage locations or methods.
Warning: Store all USG Sheetrock® Brand gypsum panels flat. Panels are heavy and can fall over, causing serious injury or death. Do not move unless authorized.
- D. Handling: Handle in such a manner to prevent racking, distortion or physical damage of any kind.

1.07 Project Conditions

- A. Existing conditions: include specific alteration work requirements for the project.
- B. Environmental requirements:
 - 1. Building conditions: Building shall be enclosed with all windows and exterior doors in place and glazed and roof watertight before installation of suspension system.
 - 2. Interior temperature/humidity in building: Conditions in areas to receive Drywall Suspension Systems shall range from 60° F (16° C) to 104° F (40° C) and relative humidity of not more than 90% shall be maintained before installation of components.
 - 3. In cold weather during gypsum panel installation and joint finishing and veneer plaster application, temperatures within the building shall be maintained in the range of 55-70° F (13-21° C). Heat and ventilation should be evenly provided to facilitate curing and drying.
- C. Coordination with other work:
 - 1. General: Coordinate with other work supported by or penetrating through the ceiling, including mechanical and electrical work and partition systems.
 - 2. Mechanical work: Ductwork above system shall be complete and permanent HVAC systems operating.
 - 3. Electrical work: Installation of conduit above suspension system shall be complete before installation of suspension system.
- D. Protection:
 - 1. Personnel: Follow good safety and industrial hygiene practices during handling and installing of all products and systems, with personnel taking necessary precautions and wearing appropriate personal protective equipment as needed. Read material safety data sheets and related literature for important information on products before installation. Contractor to be solely responsible for all personal safety issues during and subsequent to installation; architect, specifier, owner and manufacturer will rely on contractor's performance in these matters.

2: Products

2.01 Manufacturer

- A. USG Drywall Suspension System.
- B. USG Sheetrock® Brand gypsum panels (Regular, Firecode, Firecode C) and 1/2" USG Sheetrock® Brand brand interior gypsum ceiling board.
- C. USG Sheetrock® Brand joint tape, joint compounds, trim and accessories (see USG Gypsum Panels and Accessories SA927-09250 Specification).
- D. USG Imperial® Brand gypsum base (see USG Plaster Systems Specification SA920-0920). All manufactured by USG, Chicago, IL, USA. Manufactured in accordance with ASTM C635.

APPLICATION GUIDE SPECIFICATIONS

Curved Drywall Ceilings

2.02 Materials

- A. Commercial-quality, cold-rolled steel, hot-dipped galvanized finish
- B. USG Flat Drywall Suspension Systems:
 - 1. Main tees: Heavy Duty classification 1-1/2" high with 1-1/2" wide face
Vault Main Tees: DGW6VT
Valley Main Tess: DGW6VY
 - 2. Cross members: Fire-Rated members with knurled face.
Cross Tees: DGLW-424 cross tee 1-1/2" high x 48" long with 1-1/2" wide face. Tees must have quick-release cross-tee ends to provide positive locking and removability without the need for tools.
 - 3. Accessory cross tees: Cross tees must have knurled faces. Cross tees have quick-release cross-tee ends to provide positive locking and removability without the need for tools.
DGL224 Fire-Rated 1-1/2" high x 24" long with 15/16" face
DGL424 Fire-Rated 1-1/2" high x 48" long with 15/16" face
DGLW224 Fire-Rated 1-1/2" high x 24" long with 1-1/2" face
DGLW424 Fire-Rated 1-1/2" high x 48" long with 1-1/2" face
- C. USG Curved Drywall Suspension Systems:
 - 1. Valley tees (face of grid convex): 1-1/2" high x 1-1/2" knurled face with partially corrugated bulb and cross-tee holes at 8" OC Made of hot-dipped galvanized steel.
 - 2. Vault tees (face of grid concave): 1-1/2" high x 1-1/2" knurled face with cross-tee holes at 8" OC made of hot-dipped galvanized steel.
- D. Accessories
 - 1. Transition clip DGTC-90
 - 2. Splice clip DGSC-180
 - 3. Wall attachment clip DGWC
 - 4. Splice plate
 - 5. Hub DGHUB
- E. Gypsum panels
 - 1. Gypsum panels manufactured in accordance with ASTM C36.
 - 2. 1/4", 3/8", 1/2", 5/8" USG Sheetrock® Brand gypsum panels (Regular, Firecode, Firecode C) (see USG Drywall/Steel Framed Systems Specifications—SA923 09250-USG-3).
- F. USG Sheetrock® Brand drywall accessories: trims, expansion joints, sealants, joint compound materials (see USG Gypsum Panels & Accessories Specifications SA927 09250).

2.03 Metal, Paper or Plastic Trim

- A. Corner bead: Minimum #26 gauge, zinc alloy with or without paper flanges or plastic bead.
- B. Casing bead: Minimum #24 gauge, zinc alloy or plastic with expanded flanges.
- C. Control joints: Minimum #26 gauge, zinc alloy, extruded aluminum or plastic with expanded flanges.

2.04 Fasteners

- A. Conventional gypsum panel fasteners (ASTM C1002). No. 6 Type-S, HiLo bugle head, self-drilling, self-tapping steel screws.

Curved Drywall Ceilings

3: Execution

3.01 Inspection

- A. Examine areas to receive materials for conditions that will adversely affect installation. Provide written report of unacceptable surface.
- B. Do not start work until unsatisfactory conditions are corrected.
- C. Work to be concealed: Verify work above ceiling suspension system is complete and installed in manner that will not affect layout and installation of suspension system components.
- D. Beginning of installation shall signify acceptance of conditions in areas to receive ceiling suspension system.

3.02 Preparation

- A. Field dimensions must be verified prior to installation.

3.03 Installation

- A. Standard reference: Install in accordance with ASTM C636, CISCA installation standards and other applicable code references
- B. Manufacturer's reference: Install in accordance with manufacturer's current printed recommendations.
- C. Drawing reference: Install in accordance with approved shop drawings and locate ceiling in accordance with main-tee dimensions relative to elevations.
- D. Component and hanger-wire installation:
 - Flat ceilings:** Main tees shall be spaced a maximum of 48" on center and supported by hanger wires spaced a maximum 48" on center and as specified by UL Fire Resistance Directory, attaching hanger wires directly to structure above.
 - Cross tees shall be spaced per manufacturer's recommendations and as specified by UL Fire Resistance Directory.
 - Curved ceilings:** Valley and vault main tees shall be spaced a maximum 48".
 - Hanger wires shall be spaced a maximum 48" for vaults main tees.
 - Hanger wires shall be spaced a maximum 24" for valley main tees.
 - Cross tees shall be spaced as per manufacturer's recommendations.
 - Additional hanger wires may be necessary to stabilize any curved ceiling during and after drywall attachment.
 - Transitions: changes in elevation in soffit and fascia ceiling applications.** When constructing stepped soffits, bracing of the Drywall Suspension System and/or additional hanger wires may be necessary to ensure stability and structural performance during and after drywall attachment.
 - The maximum vertical soffit height is 48". (Maximum unsupported drywall area shall not exceed 48" x 24".) Intermediate cross tees are not necessary when bulkhead dimensions do not exceed 24".
 - Cross-tee spacing in horizontal soffit plane is not to exceed 24". Intermediate cross tees may be necessary to maintain visually acceptable drywall planes and drywall corners.
- E. USG Drywall Suspension System (when used with USG Sheetrock® Brand gypsum panel) lifetime limited warranty: "Lifetime" is defined as the useful life of a ceiling up to a maximum of 30 years. The USG Drywall Suspension System installed without USG Sheetrock® Brand brand gypsum panels has a 10-year warranty.
 - General hanger wire notes:** Hanger wires are required within 12" on both sides of a pivoted splice clip. At least 1 hanger wire is required within 12" of a transition clip.
 - Limitations:** Do not support wires from mechanical and/or electrical equipment occurring above ceiling.
- F. Accessories: Install accessories as applicable to meet project requirements.

3.04 Gypsum Panel Installation

- A. Apply gypsum panels first to ceiling and then to walls. Position all ends and edges of gypsum panels at framing members. Extend ceiling board to corners and make firm contact with the wall angle, channel or top plate. To minimize end joints, use panels of maximum practical lengths. Fit ends and edges closely, but do not force together.
- B. Cut ends and edges, scribe, or make cutouts within the field of panels in a workmanlike manner. Cut gypsum board to size using a knife and straight edge.

APPLICATION GUIDE SPECIFICATIONS

Curved Drywall Ceilings

- C. Attach gypsum panels to the suspension system main runners, cross tees and cross channels with conventional gypsum panel fasteners (No. 6 Type S HiLo bugle head, self-drilling, self-tapping steel screws) spaced 8" OC at periphery of gypsum panels and located 3/8" in from panel edges and spaced 12" OC in the field. Drive fasteners in field of panels first, working toward ends and edges. Hold panels in firm contact with framing while driving fasteners. Drive fastener heads slightly below surface of gypsum panels in a uniform dimple without breaking face paper. (See Gypsum Panel and Accessories Specification SA927 09250.)
- D. Install trim at all internal and external angles formed by the intersection of panel surfaces or other dissimilar materials. Apply corner bead to all vertical or horizontal external corners in accordance with manufacturer's directions.

Ceilings note:

Spacing of drywall grid is designed to support only the dead load. Heavy, concentrated loads should be independently supported. Lighting fixtures or troffers, air vents, and other equipment should be separately supported from the structure; gypsum panels will not support these items.

To prevent objectionable sag in new gypsum panel ceilings, the weight of overlaid unsupported insulation should not exceed 1.3 psf for 1/2" thick gypsum panels with spacing of 24" OC; 2.2 psf for 1/2" thick gypsum panels 16" OC framing, 1/2" USG Sheetrock® Brand UltraLight interior gypsum ceiling panels on 24" OC framing, and 5/8" panels 24" OC; 3/8" gypsum panels must not be overlaid with unsupported insulation. A vapor retarder should be installed in exterior ceilings, and plenum or attic spaces should be properly vented. During periods of cold or damp weather when a polyethylene vapor retarder is installed on ceilings behind the gypsum panels, it is important to install the ceiling insulation before or immediately after installing the gypsum panels. Failure to follow this procedure may result in moisture condensation in the back of the gypsum panels, causing sag.

- E. Spray-textured ceilings: Where water-based texturing materials or any slow-drying surface treatment is used over single-layer panels, maximum frame spacing is 16" OC for 1/2" panels applied perpendicular to framing, 24" OC for 1/2" USG Sheetrock® Brand UltraLight Panels.

**3.05
Expansion Joints**

- A. Provide a separation in the suspension system at expansion joints as shown on the drawings and carry the joint through the gypsum panels. Expansion joints are installed between two main tees to separate the suspension system and allow for movement in large ceiling areas.

**3.06
Control Joints**

- A. Provide control joint No. 093, which has a 3/32" groove for drywall and veneer plaster. Ceiling areas should not exceed 2,500 sq. ft. with perimeter relief or 900 sq. ft. without perimeter relief.

**BEAUTIFUL
RESULTS
EVERY TIME**

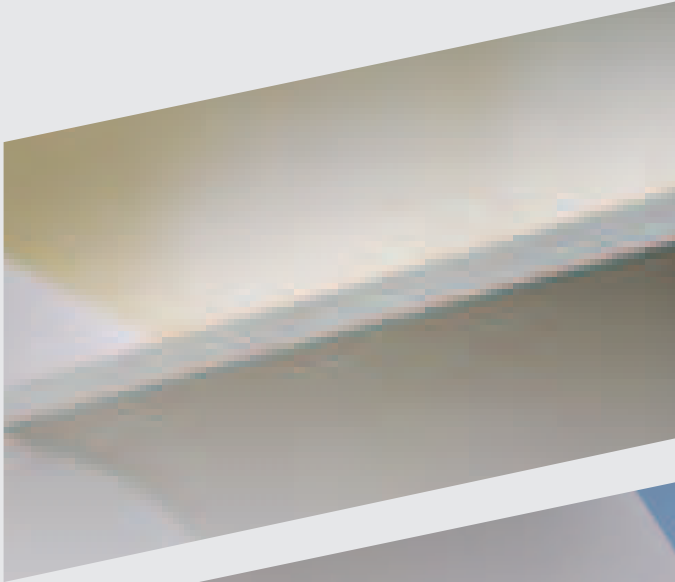

PRODUCT INFORMATION

See usg.com for the most up-to-date product information.

NOTE

All products described here may not be available in all geographic markets. Consult your local sales office or representative for information.

TRADEMARKS

The trademarks USG, AQUA-TOUGH, CENTRICITEE, COMPASSO, DIAMOND, DONN, DUROCK, DX, DXL, FIBEROCK, FIRECODE, IMPERIAL, LEVELROCK, QUICK-RELEASE, RED-TOP, SECUROCK, SHEETROCK, STRUCTO-BASE, STRUCTO-GAUGE, IT'S YOUR

WORLD. BUILD IT., the USG logo, and related marks are trademarks of USG Corporation or its affiliates.

PATENTS

The following are the patent numbers for the USG Drywall Suspension System and its components: 5,937,605; 6,018,923; 6,047,512; and 6,138,425.

NOTICE

We shall not be liable for incidental and consequential damages, directly or indirectly sustained, nor for any loss caused by application of these goods not in accordance with current printed instructions or for other than the intended use. Our liability is expressly

limited to replacement of defective goods. Any claim shall be deemed waived unless made in writing to us within thirty (30) days from date it was or reasonably should have been discovered.

SAFETY FIRST!

Follow good safety and industrial hygiene practices during handling and installation of all products and systems. Take necessary precautions and wear the appropriate personal protective equipment as needed. Read material safety data sheets and related literature on products before specification and/or installation.

TECHNICAL SERVICE

800 USG.4YOU

WEBSITE

usg.com

SAMPLES/LITERATURE

888 874.2450

CUSTOMER SERVICE

800 950.3839

SAMPLES/LITERATURE EMAIL

samplit@usg.com

SAMPLES/LITERATURE FAX

888 874.2348