



ICC-ES Evaluation Report

ESR-4358

Reissued June 2023

Revised November 2023

This report is subject to renewal June 2024.

DIVISION: 09 00 00—FINISHES
Section: 09 22 26—Suspension Systems

REPORT HOLDER:

USG INTERIORS, LLC

EVALUATION SUBJECT:

USG™ DRYWALL SUSPENSION SYSTEMS

1.0 EVALUATION SCOPE

Compliance with the following codes:

- 2021, 2018, 2015, 2012, 2009 and 2006 *International Building Code*® (IBC)

For evaluation for compliance with codes adopted by Los Angeles Department of Building and Safety (LADBS), see [ESR-4358 LABC Supplement](#).

For evaluation for compliance with codes adopted by California Office of Statewide Health Planning and Development (OSHPD) and Division of the State Architect (DSA), see [ESR-4358 CBC Supplement](#).

Properties evaluated:

- Interior finish
- Fire resistance
- Structural

2.0 USES

The USG drywall suspension systems described in this report are used as a ceiling framing system for screw—attached gypsum panel products in interior applications used in fire-resistance-rated and non-fire-resistance-rated construction for applications as noted in this report.

3.0 DESCRIPTION

3.1 USG™ Drywall Suspension Systems: The USG™ Drywall Suspension System consists of main and cross runner framing members as described in Section 3.2 for use with gypsum wallboard and wood-based products attached to the bottom of the framing members.

3.2 Accessories:

Each suspended ceiling system is available with a variety of wall angles, moldings, access angles and corner caps.

3.3 DGLW Series Runners:

The DGLW-26 main tees and DGLW and DGW-DM cross tees are double-webbed T-shape profile, with a knurled 1½-inch flange for easier screw penetration. The main tees are classified as heavy duty in accordance with ASTM C635. The main and cross tees are cold-formed steel meeting ASTM A653 CS Type B, having a thickness of 0.018-inch and that are hot-dipped galvanized coating of G40 or higher. See Table 1 for product information and Figure 2 for runner section profiles.

3.4 Hanger Wire: Hanger wire for suspended ceiling framing members, and fixtures, must comply with ASTM C636 as referenced in 2021, 2018, 2015, 2012 and 2009 IBC Section 808.1.1.1 (2006 IBC Section 803.9.1.1) and Section 13.5.6 of ASCE 7 as referenced in IBC Section 2506.2.1.

4.0 DESIGN AND INSTALLATION

4.1 Design:

Suspended ceilings constructed of lath and plaster or gypsum boards, screw or nail attached to suspended members that support a ceiling on one level that are surrounded by and connected to walls or soffits that are laterally braced to the structure above are exempt from the lateral load design requirements of ASTM E580 and CISCA for Seismic Zones 3-4, and as referenced in Section 13.5.6 of ASCE 7-16 under the 2021 and 2018 IBC and ASCE 7-10 under the 2015 and 2012 IBC, in accordance with IBC Section 1613. The ceiling must be designed for seismic loads as required under Chapter 13.3 of ASCE 7-16 for the 2021 and 2018 IBC (ASCE 7-10 for the 2015 and 2012 IBC and ASCE 7-05 for the 2009 and 2006 IBC) as referenced in IBC Section 1613. The ceiling weight must not exceed 10 psf. The capacity of the DGLW and DGW-DM runners must not exceed the allowable load values shown in Table 1 of this report. As an alternate to the design and installation of ceiling assemblies in this section, the suspended ceiling assemblies described in Section 4.3 may be installed.

4.2 Installation:

4.2.1 General: The ceiling systems must be installed in accordance with this report, approved construction documents and the manufacturer’s published installation instructions.

4.2.2 The installation must be in accordance with manufacturer’s written instructions, ASTM C636 or ASTM

C1858 and applicable provisions of IBC Chapter 25. The suspended ceiling system must be installed in a manner where the published values of the DGLW and DGW-DM series runners in Table 1, 2A and 2B are not exceeded. The gypsum board must be fastened to runners in accordance with the applicable provisions in IBC Chapter 25.

4.3 Alternate Seismic Installations based in accordance with Section 13.2.5 of ASCE 7:

4.3.1 Alternate Seismic Installation No. 1 Seismic Design Categories D, E and F: Ceiling systems under this installation may be installed in Seismic Design Categories D, E and F (maximum design spectral response acceleration at short period, S_{ds} , 2.0 g) supporting a maximum of two layers of gypsum boards having a maximum combined weight of 4 psf. The main runners must be installed at a maximum spacing of 48 inches on center supported by hanger wires at maximum 48 inches on center. The maximum spacing of cross runners must not exceed 24 inches. Each runner end at perimeter of ceiling must be attached to supporting wall with 20 gage thick steel wall molding using one screw. The wall molding must be attached to the wall framing. The gypsum ceiling boards must be screwed to the runners in accordance with IBC Chapter 25.

4.3.2 Alternate Seismic Installation No. 2 Seismic Design Categories D, E and F: Ceiling systems under this installation may be installed in Seismic Design Categories D, E and F (maximum design spectral response acceleration at short period, S_{ds} , 2.0 g) supporting a maximum of two layers of gypsum boards having a maximum combined weight of 4 psf. The main runners must be installed at a maximum spacing of 48 inches on center supported by hanger wires at maximum 48 inches on center. The maximum spacing of cross runners must not exceed 24 inches. The ceiling must be fixed to supporting walls on three sides and be detached to supporting wall on one side. Each runner end at the fixed side of the ceiling must be attached to supporting wall with 20 ga. thick steel wall molding using one screw. The wall molding must be attached to wall framing. On the detached side of the ceiling, the runner ends must be attached to the wall molding. The wall molding must not be attached to wall framing on the detached side. The gypsum ceiling boards must be screwed to the runners in accordance with IBC Chapter 25.

4.3.3 Alternate Seismic Installation No. 3 Seismic Design Categories D, E and F: Ceiling systems under this installation may be installed in Seismic Design Categories D, E and F (maximum design spectral response acceleration at short period, S_{ds} , 2.0 g) supporting a maximum of two layers of gypsum boards having a maximum combined weight of 4 psf. The main runners must be installed at a maximum spacing of 48 inches on center supported by hanger wires at maximum 48 inches on center. The maximum spacing of cross runners must not exceed 24 inches. The ceiling includes a maximum 12-inch elevation change. A USG™ DGTC90 transition clip and cross tee must be used to connect the main runners at each ceiling elevation. See Figure 3 for elevation change detail. Each runner end at perimeter of ceiling must be attached to supporting wall with 20 gage thick steel wall molding using one screw. The wall molding must be attached to the wall framing. The gypsum ceiling boards must be screwed to the runners in accordance with IBC Chapter 25.

4.3.4 Alternate Seismic Installation No. 4 Seismic Design Categories D, E and F: Ceiling systems under this installation may be installed in Seismic Design Categories D, E and F (maximum design spectral response acceleration at short period, S_{ds} , 2.0 g) supporting a

maximum of four layers of gypsum boards having a maximum combined weight of 10 psf. The main runners must be installed at a maximum spacing of 24 inches on center supported by hanger wires at maximum 24 inches on center. The maximum spacing of cross runners must not exceed 16 inches. Each runner end at perimeter of ceiling must be attached to supporting wall with 20 gage thick steel wall molding angle using one screw. The wall molding must be attached to the wall framing. The gypsum ceiling boards must be screwed to the runners in accordance with IBC Chapter 25.

4.4 USG™ Drywall Suspension System Fire-resistance-rated Construction: The USG™ Drywall Suspension Systems are concealed, direct-hung grid systems that can be utilized as part of a fire-resistive floor-ceiling assembly as shown in Figure 1, with ratings as listed in Table 3. The main runners are either Type DGLW main runners. The cross runners are Type DGLW cross runners, except that Type DGLW cross runners are used around recessed light fixtures.

The ratings apply to restrained and unrestrained assemblies as described in ASTM E119, which is referenced in IBC Section 703. General requirements of 2021, 2018, 2015 and 2012 IBC Section 711.1 (2009 IBC Section 712.1 and 2006 IBC Section 711.1) must be observed.

4.5 Special Inspection:

Where special inspections are required by the building official, suspended ceilings in Seismic Design Categories C, D, E and F, shall be subject to periodic special inspections during the installation of the suspended ceiling systems and their anchorage, in accordance with the following requirements: For installations in accordance with Section 4.3 of this report, special inspection must be conducted as required by the building official during enforcement of the 2021, 2018 and 2015 IBC sections 1705.1.1, 1704.5 and 1705.13.2 (2012 IBC Sections 1705.1.1, 1705.11.4, and Section 1705.12; 2009 IBC Section 1704.15, 1708.4 and Item 3 of Section 1708.1; 2006 IBC Section 1704.13, 1708.5 and Item 3 of Section 1708.2), as applicable. The special inspector must verify that the ceiling system is as described in this report, and complies with the installation instructions in this report, and with the approved construction documents.

Where special inspections are required by the building official, a statement of special inspections must be provided as required in 2021, 2018, 2015 and 2012 IBC Section 1704.3 (2009 IBC Section 1705.3.4, Item 3; and 2006 IBC Section 1705.3, Item 4.3).

5.0 CONDITIONS OF USE

The USG Drywall Suspension Systems described in this report comply with, or are suitable alternatives to what is specified in, those codes listed in Section 1.0 of this report, subject to the following conditions:

- 5.1** The ceiling suspension main runners and cross runners, are fabricated and installed in accordance with this report and the manufacturer's published installation instructions. In the event of a conflict between the manufacturer's installation instructions and this report, this report governs.
- 5.2** Design loads and spans of main and cross runners must comply with Table 1 of this report.
- 5.3** Where required by the building official, special inspections must be provided in accordance with Section 4.5 of this report.
- 5.4** The ceiling framing systems must not be used to provide lateral support for walls or partitions, except as

provided for in ASCE 7, Section 13.5.8.1, as referenced in IBC Section 1613.

- 5.5 The supporting construction for the ceiling system has not been evaluated and is outside the scope of this report. The code official must approve the construction supporting the suspended ceiling system.
- 5.6 The ceiling systems are limited to ceilings not considered accessible in accordance with Item 29 of 2021 IBC Table 1607.1 (Item 28 of 2018, 2015 and 2012 IBC Table 1607.1; Item 31 of 2009 IBC Table 1607.1; and Item 32 of 2006 IBC Table 1607.1).
- 5.7 The ceiling systems are limited to interior application. For exterior ceiling installations, the ceiling systems must be designed for wind loads and with due consideration of atmospheric conditions.
- 5.8 Lighting fixtures and mechanical services may be supported by the suspended ceiling framing members or structure above. The connection of the fixture to the suspended ceiling framing member must be designed to withstand 100 percent of the fixture weight.

6.0 EVIDENCE SUBMITTED

- 6.1 Data in accordance with the ICC-ES Acceptance Criteria for Suspended Ceiling Framing Systems (AC368), dated November 2019 (editorially revised March 2021).

- 6.2 Data in accordance with the ICC-ES Acceptance Criteria for Seismic Certification by Shake-table Testing of Nonstructural Components (AC156), dated October 2010 (editorially revised December 2020).

- 6.3 Reports of fire-resistance tests in accordance with ASTM E119.

7.0 IDENTIFICATION

- 7.1 Cartons of framing members, clips and accessories are identified with the name and address of USG Interiors, LLC, the manufacturing location, the framing member designations and the evaluation report number (ESR-4358).

- 7.2 The report holder's contact information is the following:

USG INTERIORS, LLC
550 WEST ADAMS STREET
CHICAGO, ILLINOIS 60661
(800) 874-4968
www.usg.com
usg4you@usg.com

TABLE 1—DRYWALL SUSPENSION SYSTEMS FLAT CEILINGS DIMENSIONS AND ALLOWABLE LOADS FOR FRAMING MEMBERS

| Part Number | Profile | Member | Length of Member (inches) | Height of Member (inches) | Maximum Span (inches) | Allowable Uniform Load (pounds per linear foot) |
|------------------------|---------|-----------|---------------------------|---------------------------|-----------------------|---|
| DGLW 26 ² | M | Main Tee | 144 | 1.62 | 48 | 16 |
| DGW 26s | M | Main Tee | 72 - 168 | 1.62 | 48 | 16 |
| DGLW 624 | N | Cross Tee | 72 | 1.50 | 72 | 4.45 |
| DGLW 224 ² | N | Cross Tee | 24 | 1.50 | 24 | 73.2 ¹ |
| DGLW 2624 ² | N | Cross Tee | 26 | 1.50 | 26 | 57 ¹ |
| DGLW 424 ² | N | Cross Tee | 48 | 1.50 | 48 | 12.1 |
| DGLW 50 ² | N | Cross Tee | 50 | 1.50 | 50 | 11 |
| DGW-6026DM | M | Cross Tee | 60 | 1.62 | 60 | 23.6 |
| DGW-7226DM | M | Cross Tee | 72 | 1.62 | 72 | 17.1 |
| DGW-8426DM | M | Cross Tee | 84 | 1.62 | 84 | 10.6 |
| DGW-9626DM | M | Cross Tee | 96 | 1.62 | 96 | 4.1 |

For SI: 1 inch= 25.4, 1 plf=14.6 N/m.

¹The maximum uniform load must not exceed the capacity of the supporting element and the uniform load values described in Tables 2A and 2B of this report.

²Fire-resistance rated.

TABLE 2A- CEILING UNIFORM LOAD¹

| Main Runner Deflection Criteria | L/240 | | | | | | | | | | | |
|------------------------------------|-------|------|------|------|------|------|------|-----|------|-----|-----|-----|
| Hanger Wire Spacing (inches) | 24 | | | | 36 | | | | 48 | | | |
| Main Tee Spacing (inches) | 24 | 36 | 48 | 72 | 24 | 36 | 48 | 72 | 24 | 36 | 48 | 72 |
| Maximum Ceiling Uniform Load (psf) | 10.0 | 10.0 | 10.0 | 10.0 | 10.0 | 10.0 | 10.0 | 9.5 | 10.0 | 8.0 | 6.0 | 4.0 |

For SI: 1 inch=25.4 mm; 1 psf= 47.88 Pa.

TABLE 2B- CEILING UNIFORM LOAD¹

| Main Runner Deflection Criteria | L/360 | | | | | | | | | | | |
|------------------------------------|-------|------|------|------|------|------|------|-----|------|-----|-----|-----|
| Hanger Wire Spacing (inches) | 24 | | | | 36 | | | | 48 | | | |
| Main Tee Spacing (inches) | 24 | 36 | 48 | 72 | 24 | 36 | 48 | 72 | 24 | 36 | 48 | 72 |
| Maximum Ceiling Uniform Load (psf) | 10.0 | 10.0 | 10.0 | 10.0 | 10.0 | 10.0 | 10.0 | 9.5 | 10.0 | 8.0 | 4.0 | 2.7 |

For SI: 1 inch=25.4 mm; 1 psf= 47.88 Pa.

Footnotes for Tables 2A and 2B:

¹ Cross tee spacing must not exceed 24 inches on center and loads must not exceed published values in Table 1 of this report.

TABLE 3—FIRE-RESISTANCE-RATED ASSEMBLIES

| RESTRAINED OR UNRESTRAINED ASSEMBLY RATING (hours) | UNRESTRAINED BEAM RATING (hours) | CONCRETE THICKNESS (inches) | WALLBOARD THICKNESS (inch) |
|--|----------------------------------|-------------------------------|-----------------------------|
| 2 | 3 | 2 ¹ / ₂ | ¹ / ₂ |
| 3 | 3 | 3 ¹ / ₄ | ¹ / ₂ |
| 3 | 3 | 2 ³ / ₄ | ⁵ / ₈ |

For SI: 1 inch = 25.4 mm.

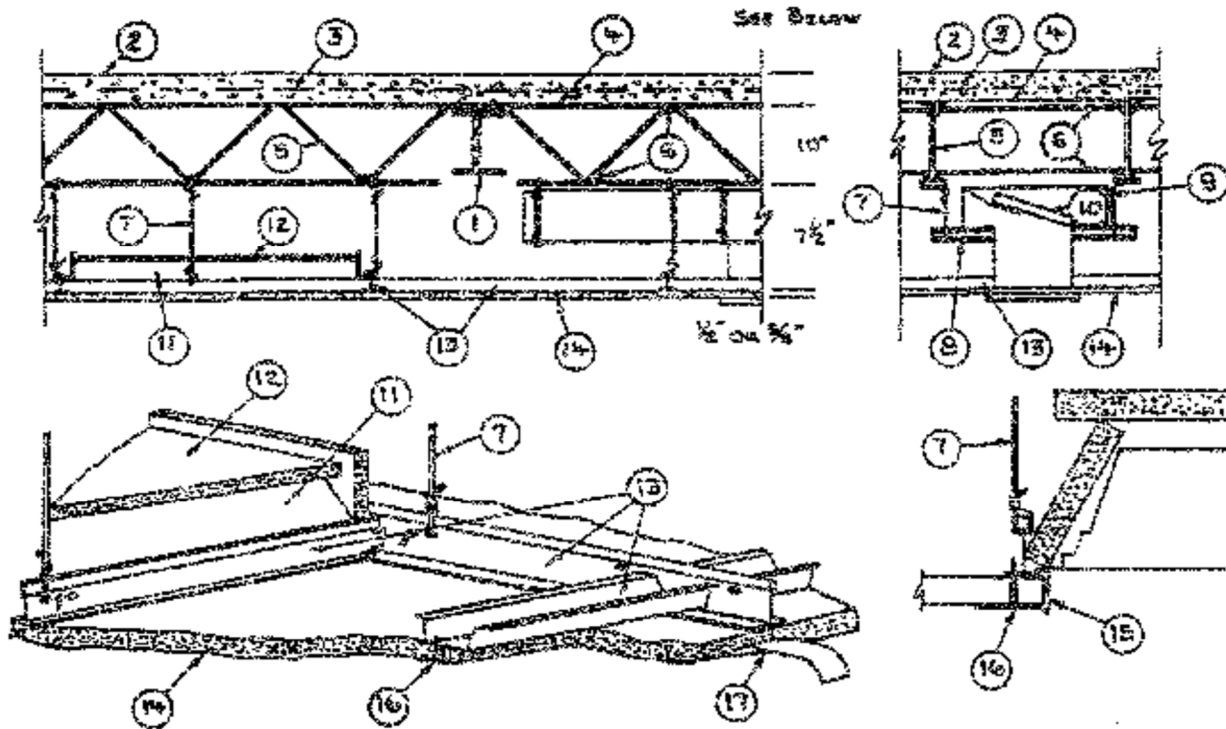

For SI: 1 inch = 25.4 mm, 1 pcf = 16.02 kg/m³, 1 psi = 6.89 kPa, 1 pound/yard² = 0.54 kg/m², 1 inch² = 645.16 mm², 1 foot² = 0.0929 m².

1. **Beam**—W8 × 24, minimum size.
2. **Normal-weight Concrete**—Carbonate or siliceous aggregate, 152 pcf ± 3 pcf unit weight, 4,500-psi compressive strength.
3. **Welded Wire Fabric**—6 by 6 inches, 10/10 SWG.
4. **Metal Lath**—³/₈-inch rib, 3.4-pound-per-square-yard expanded steel. Tied to each joist at every other rib and midway between joints at side lap with 18 SWG galvanized steel wire.
5. **Steel Joists**—Type 10J2 minimum size, spaced 24 inches on center, welded to end supports.
6. **Bridging**—¹/₂-inch-diameter steel bars welded to top and bottom chords of each joist.
7. **Hanger Wire**—No. 12 SWG galvanized steel wire tied to lower chord of joists or cold-rolled channels tied face to face with No. 18 SWG galvanized wire. Hanger wires spaced a maximum of 48 inches on center along main runners and located at ends of main runners at walls and at corners and midspan along 4-foot sides of light fixtures.
8. **Cold-rolled Channels**—No. 16 MSG cold-rolled steel, 1¹/₂ inches deep.
9. **Air-Duct**—No. 20 MSG galvanized steel. Total area of duct openings not to exceed 57 square inches per 100 square feet of ceiling area. Area of individual duct openings not to exceed 113 square inches. Maximum dimension of opening is 12 inches. Duct supported by cold-rolled channels, spaced approximately 24 inches on center.
10. **Damper**—No. 16 MSG galvanized steel, 16 by 16 inches, protected on both surfaces with ¹/₁₆-inch-thick ceramic fiber paper and held open with a listed fusible link. Damper to overlap duct outlet a minimum of 1 inch.
11. **Fixtures, Recessed Light**—Listed fluorescent-lamp type, steel housing, 2-by-4-foot size. Fixtures spaced so their area does not exceed 24 square feet per 100 square feet of ceiling area. Fixtures and ballasts must be considered for these ambient temperature conditions before installation.
12. **Fixture Protection**—Wallboard, gypsum—¹/₂- and ⁵/₈-inch-thick gypsum wallboard (SHEETROCK FIRECODE Type "C" as manufactured by United States Gypsum Company), cut into pieces to form a four-sided enclosure, trapezoidal in cross section, approximately ¹/₂ inch longer and wider than the fixture, with sufficient depth to provide at least ¹/₂ inch clearance between the fixture and the enclosure.
13. **Steel Framing Members**—Type DGL or DGLW—main runner tees, 12 feet long, spaced 4 feet on center. Main runner ends interlocked by an integral splice end detail. Type DGLW or DGCL cross channels, measuring 4 feet long, installed perpendicular to the main runners, spaced 24 inches on center. Additional channels placed 8 inches from light fixtures and from butted end joints. Channels clipped into main runner slots and secured to wall angle using ¹/₂-inch-long self-drilling and self-tapping screws having a thread diameter of 0.138 inch and a ⁵/₁₆-inch head diameter. The Type DGL cross tees, used to support the 4-foot sides of light fixtures, are 4 feet long and installed perpendicular to the main runners.
14. **Gypsum Wallboard**—¹/₂- and ⁵/₈-inch-thick gypsum wallboard (SHEETROCK FIRECODE Type "C" as manufactured by United States Gypsum Company), 4 feet wide, installed with the long dimension perpendicular to cross channels, with side joints centered along main runners. Wallboard fastened to cross channels using 1-inch-long wallboard screws located ¹/₂ inch from end joints and 1³/₄ inches from each side joint, and spaced 12 inches on center along the end joints and in the field.
15. **Metal Trim Molding**—No. 22 MSG molding measuring ⁵/₈ inch wide, with ⁹/₁₆- and 1³/₈-inch-long legs placed on wallboard edges around light fixtures and secured to the cross tees and main runners using 1-inch-long wallboard screws. Spacing of screws approximately 8 inches on center along the 4-foot side and 10 inches on center along the 2-foot side of light fixtures.
16. **Screw, Wallboard**—Type S-12, 1 inch long, self drilling and self tapping, 0.163-inch thread diameter, ⁵/₁₆-inch head diameter.
17. **Finishing System**—Paper tape embedded in compound over joints and covered with additional compound. Exposed screw heads covered with compound. Edges of compound feathered out.
18. **Wall Angle**—(Not shown)—No. 26 MSG angle with 1¹/₈-inch legs, nailed to the walls supporting the cross channels.

FIGURE 1—FIRE-RESISTIVE FLOOR-CEILING ASSEMBLY UTILIZING THE USG DRYWALL SUSPENSION SYSTEM

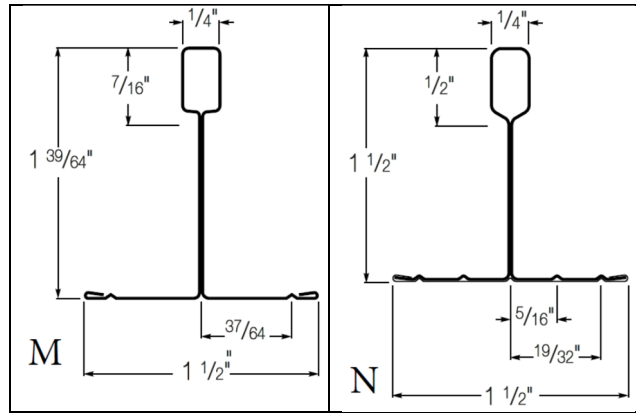
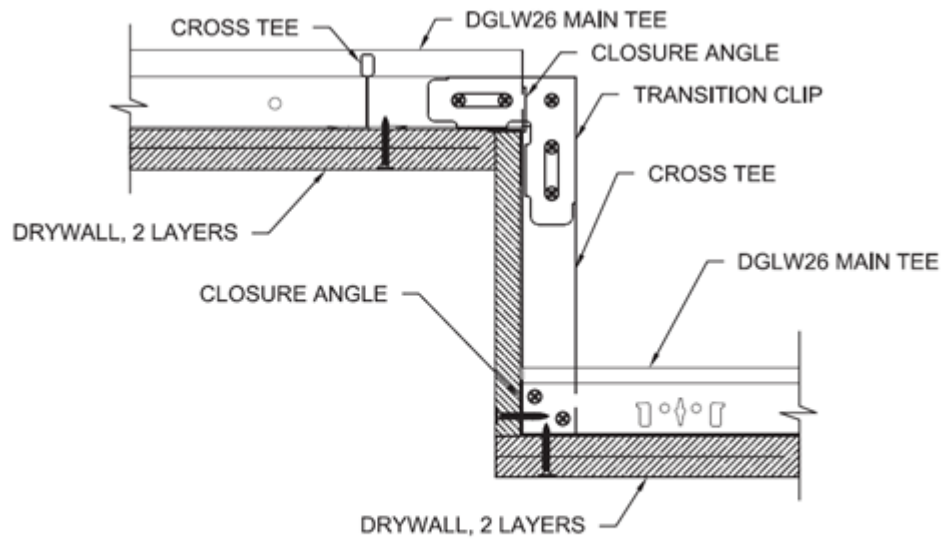

FIGURE 2—SUSPENSION SYSTEM PROFILES



SECTION D-D

FIGURE 3—ELEVATION CHANGE DETAIL WITH USG TRANSITION CLIP

DIVISION: 09 00 00—FINISHES

Section: 09 22 26—Suspension Systems

REPORT HOLDER:

USG INTERIOR, LLC

EVALUATION SUBJECT:

USG™ DRYWALL SUSPENSION SYSTEMS

1.0 REPORT PURPOSE AND SCOPE

Purpose:

The purpose of this evaluation report supplement is to indicate that the USG drywall suspension systems, described in ICC-ES evaluation report [ESR-4358](#), have also been evaluated for compliance with the code noted below as adopted by the Los Angeles Department of Building and Safety (LADBS).

Applicable code edition:

- 2020 *City of Los Angeles Building Code* (LABC)

2.0 CONCLUSIONS

The USG drywall suspension systems, described in Sections 2.0 through 7.0 of the evaluation report [ESR-4358](#), comply with the LABC Chapters 7, 8, 16 and 25, and are subject to the conditions of use described in this supplement.

3.0 CONDITIONS OF USE

The USG drywall suspension systems described in this evaluation report must comply with all of the following conditions:

- All applicable sections in the evaluation report [ESR-4358](#).
- The design, installation, conditions of use and identification of the USG drywall suspension systems are in accordance with the 2018 *International Building Code*® (IBC) provisions noted in the evaluation report [ESR-4358](#).
- The design, installation and inspection are in accordance with additional requirements of LABC Chapters 16 and 17, as applicable.
- Main runners shall be identified by indentation or by nontransferable decal with letters not less than 1/4-inch high, and shall include the company name, runner designation and load rating.

This supplement expires concurrently with the evaluation report, reissued June 2023 and revised November 2023.

DIVISION: 09 00 00—FINISHES**Section: 09 22 26—Suspension Systems****REPORT HOLDER:**

USG INTERIORS, LLC

EVALUATION SUBJECT:

USG™ DRYWALL SUSPENSION SYSTEMS

1.0 REPORT PURPOSE AND SCOPE**Purpose:**

The purpose of this evaluation report supplement is to indicate that USG drywall suspension systems, described in ICC-ES evaluation report ESR-4358, have also been evaluated for compliance with the code noted below.

Applicable code edition:

- 2019 *California Building Code* (CBC)

For evaluation of applicable chapters adopted by the California Office of Statewide Health Planning and Development (OSHPD) and Division of State Architect (DSA), see section 2.1 and 2.2 below

2.0 CONCLUSIONS

The USG drywall suspension systems, described in Sections 2.0 through 7.0 of the evaluation report ESR-4358, comply with CBC Chapters 7, 8, 16 and 25 provided the design and installation are in accordance with the 2018 *International Building Code*® (IBC) provisions noted in the evaluation report and the additional requirements of CBC Chapters 7, 8, 16, 17 and 25, as applicable.

2.1. OSHPD:

The USG drywall suspension systems, described in Section 2.0 through 7.0 of the evaluation report ESR-4358, comply with CBC Chapters 7, 8, 16, 17 and 25, with applicable amendments, and Chapters 16A and 17A, provided the design and installation are in accordance with the 2018 *International Building Code* (IBC) provisions noted in the evaluation report, and the additional requirements in Sections 2.1.1 through 2.1.2 of this supplement:

2.1.1. Conditions of Use:

1. All loads applied shall be determined by a registered structural engineer and shall comply with applicable loads from CBC Chapter 16 and its amendments, and Chapter 16A.
2. Section 13.5.6.2 of ASCE 7 shall be revised in accordance with CBC Section 1617A.1.21 [OSHPD 1 & 4].
3. Design and installation shall comply with the requirements of OSHPD Preapproved Details (OPD) OPD-0003-13.

2.1.2. Special Inspection Requirements:

1. Periodic special inspection is required, in accordance with Section 1705A.12.5 of the CBC [OSHPD 1 & 4].
2. Where gypsum wallboard is used in suspended ceiling installations, additional inspection shall be in accordance with CBC Section 2503.2 [OSHPD 1, 1R, 2, 4 & 5].

2.2. DSA:

The USG drywall suspension systems, described in Section 2.0 through 7.0 of the evaluation report ESR-4358, comply with CBC Chapters 7, 8, 16, 17 and 25, with applicable amendments, and Chapters 16A and 17A, provided the design and

installation are in accordance with the 2018 International Building Code (IBC) provisions noted in the evaluation report, and the additional requirements in Sections 2.2.1 through 2.2.2 of this supplement:

2.2.1. Conditions of Use:

1. All loads applied shall be determined by a registered structural engineer and shall comply with applicable loads from CBC Chapter 16 and its amendments, and Chapter 16A.
2. Section 13.5.6.2 of ASCE 7 shall be revised in accordance with CBC Section 1617.11.16 [DSA-SS/CC] and Section 1617A.1.21 [DSA-SS].
3. Design and installation shall comply with the requirements of DSA Interpretation of Regulations (IR) DSA IR 25-3.13.

2.2.2. Special Inspection Requirements:

1. Periodic special inspection is required, in accordance with Section 1705A.12.5 of the CBC [DSA-SS & DSA-SS/CC].
2. Where gypsum wallboard is used in suspended ceiling installations, additional inspection shall be in accordance with CBC Section 2503.2 [DSA-SS, DSA-SS/CC].

This supplement expires concurrently with the evaluation report, reissued June 2023 and revised November 2023.