

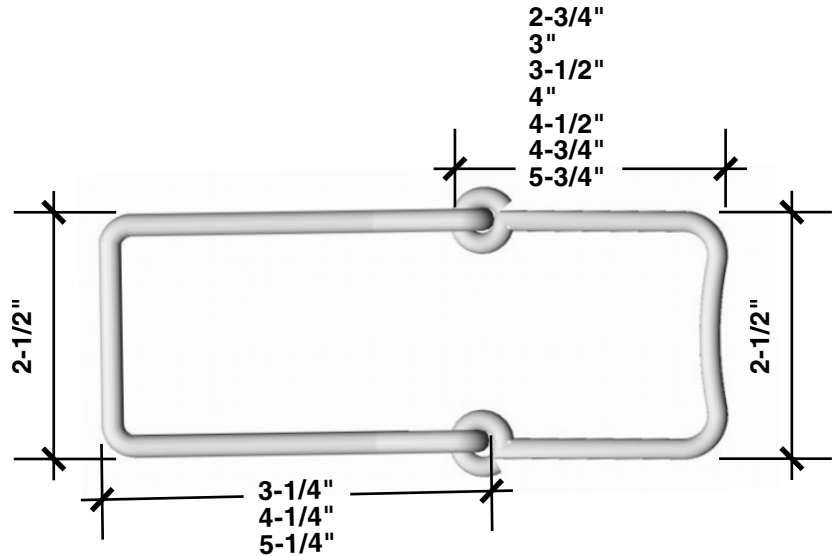

# PRODUCT SUBMITTAL

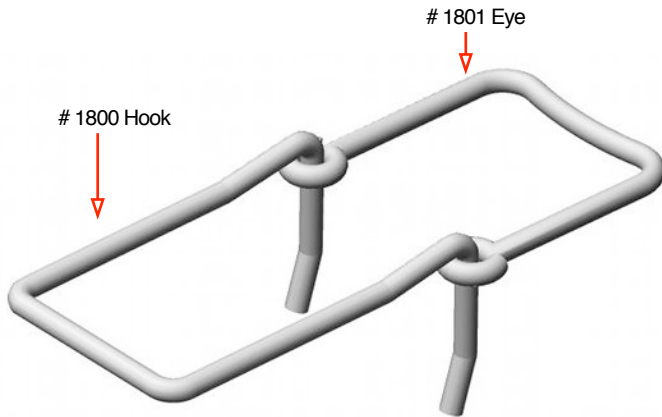

## # 1800 Hook & #1801 Eye ( Adjustable Rect. Ties )



MATERIAL CONFORMANCE	SIZES / FINISHES	
<p><b>ASTM A82 / A82M</b> - (Cold drawn steel wire) Tensile Strength - 80,000 psi Yield Point - 70,000 psi</p> <p><b>ACI / ASCE 530</b> - (Building code requirements for masonry structures)</p> <p>Mill Galvanized / Zinc Coating: <b>ASTM A641 / A641M (0.10 oz per sq ft)</b> Hot Dip Galvanized after fabrication / Zinc Coating <b>ASTM A153 / A153M-B2 (1.50 oz per sq ft)</b> Stainless Steel <b>ASTM 580 / ASTM 580M Type 304</b> (Type 316 available on special order)</p> <p><b>WIRE Recycled Content:</b> Mill Galvanized &amp; Hot Dip, 87% Post-Consumer 13% Post Industrial / Pre - Consumer</p> <p>Stainless Steel, 60% Post Consumer V O C Content - 0%</p>	<p><b># 1800 Hook Diameter:</b></p> <p><input checked="" type="checkbox"/> 3/16"Ø</p>	<p><b># 1800 Hook Length:</b></p> <p><input type="checkbox"/> 3-1/4" <input type="checkbox"/> 4-1/4" <input type="checkbox"/> 5-1/4" <input type="checkbox"/> Other _____</p>
<p style="text-align: center;"></p>	<p><b># 1801 Eye Diameter:</b></p> <p><input checked="" type="checkbox"/> 3/16"Ø</p>	<p><b># 1801 Eye Length:</b></p> <p><input type="checkbox"/> 2-3/4" <input type="checkbox"/> 3" <input type="checkbox"/> 3-1/2" <input type="checkbox"/> 4" <input type="checkbox"/> 4-1/2" <input type="checkbox"/> 4-3/4" <input type="checkbox"/> 5-3/4"</p>
	<p><b>Finishes:</b></p> <p><input type="checkbox"/> Mill Galvanized <input type="checkbox"/> Hot Dip Galvanized <input type="checkbox"/> Stainless Steel</p>	

**Corporate Office:** 400 Roundtree Rd Charlotte, NC 28217  
TEL: (800) 849-6722 FAX: (704) 525-3761

**Mailing Address:** P.O. Box 240988 Charlotte, NC 28224



[www.wirebond.com](http://www.wirebond.com)

**Memphis Plant:** 2365 Harbor Ave. Memphis, TN 38113  
TEL: (800) 441-8359 FAX: (901) 775-9449

**Mailing Address:** P.O. Box 13124 Memphis, TN 38113