

PRODUCT SUBMITTAL

WIRE-BOND

2401 RJ-721 Adjustable Veneer Anchor

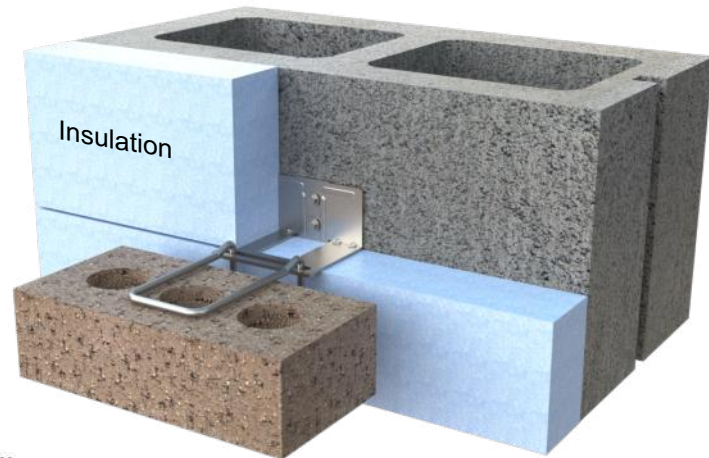
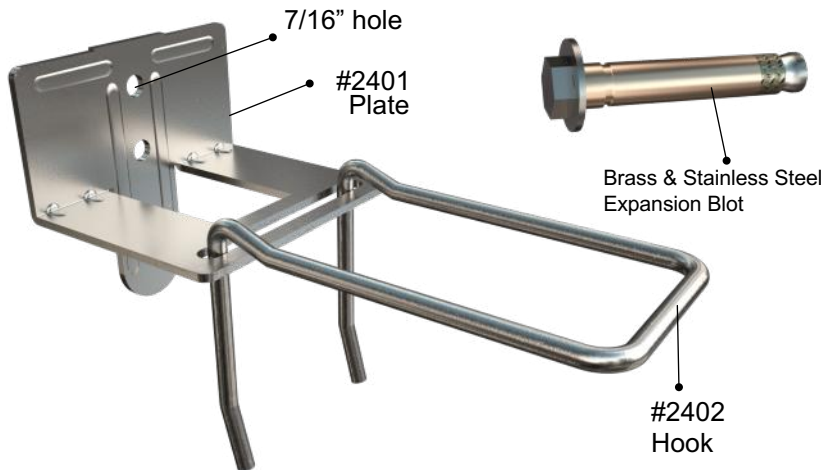

Torque Activated: 50 - 100 in - lb • Hex Head Finish - Low Profile • Bolt Head Provides Inspection Source
 Low Profile Avoids Insulation or Tie Interference • Zinc Plated or Stainless Steel with Brass Expanders • Fastener Preload ≥ Four Times Design Load

Fastener Performance				
	Ultimate Tension: lbs. (kg)			
Hollow Lightweight Block	900 lbs. (409 kg)			
N.W. Concrete (3500 psi)	2,100 lbs. (963 kg)			
Solid Brick	900 lbs. (409 kg)			
	A	B	C	D
ZINC PLATED HARDWARE	ZINC PLATED, A307 ASME B18.2.1	ZINC PLATED ANSI B18.22.1TYA	ASTM A-360 Brass	ASTM A-360 Brass
STAINLESS STEEL HARDWARE	300 SERIES STAINLESS STEEL ASME B18.2.1	ANSI B18.22.1TYA	ASTM A-360 Brass	ASTM A-360 Brass

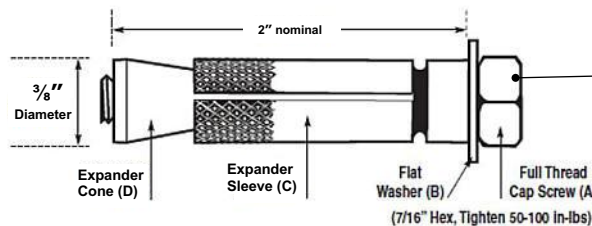

3/8" x 2"
 Stainless Steel
 Brass Sleeve
 Expansion Bolt

MATERIAL CONFORMANCE

ASTM A1064/A1064M - (Cold drawn steel wire)
 Tensile Strength - 80,000 psi
 Yield Point - 70,000 psi

ACI / ASCE 530 - (Building code requirements for masonry structures)

SHEET METAL - (Carbon Steel) **ASTM A1008 / A1008M**

Mill Galvanized / Zinc Coating: **ASTM A641 / A641M (0.10 Oz per sq ft)**

Hot Dip Galvanized after fabrication / Zinc Coating
ASTM A153 / A153M-B2 (1.50 oz per sq ft)

Stainless Steel **ASTM 580 / ASTM 580M Type 304** (Type 316 available on special order)

Recycled Content:
 Mill Galvanized & Hot Dipped,
 82.8% Post-Consumer
 17% Post Industrial / Pre-Consumer,

Stainless Steel,
 60% Post Consumer
 V O C Content - 0%



SIZES / FINISHES

2401 RJ711:
 14 gauge 12 gauge

Must be 3/4" more than insulation

Insulation:

0"	1"	1-1/2"	2"	2-1/2"
3"	3-1/2"	4"		

2402 Hook: 3/16" Diameter Standard
 3-1/4" 4-1/4" 5-1/4" Other _____

FINISH:
 Mill Galvanized Hot Dip Galvanized Stainless Steel

WIRE-BOND's standard 3/16" double hook has been tested and on average will meet a 200lbs load in both tension and compression at full disengagement at 1-1/4". This meets BIA and TMS 402/602-16 requirements for adjustable anchors.

Corporate Office: 400 Rountree Rd Charlotte, NC 28217
 TEL: (800) 849-6722 FAX: (704) 525-3761

Mailing Address: P.O. Box 240988 Charlotte, NC 28224

WIRE-BOND

www.wirebond.com

Memphis Plant: 2365 Harbor Ave. Memphis, TN 38113
 TEL: (800) 441-8359 FAX: (901) 775-9449

Mailing Address: P.O. Box 13124 Memphis, TN 38113